

MAX[®] 5300 Owner's Manual



299MAX5300

PANAMAX[®]
The Surge Protection Specialist

150 Mitchell Blvd., San Rafael, CA 94903 • www.panamax.com

MAX® 5300 Owner's Manual

Congratulations on your selection of the MAX® 5300 as the AC power source for your audio/video system! Over 25 years of power protection experience and more than 10 years of Audio/Video noise filtration engineering experience were utilized in the

development of this model. The MAX® 5300 has been specifically engineered to enhance the performance and life expectancy of Audio/Video entertainment gear. The combination of sophisticated noise filtration circuitry and the world's finest surge protection

has resulted in an Audio/Video power center that meets the power quality needs for each piece of equipment in your entertainment system. The styling of the MAX® 5300 complements even the most sophisticated Audio/Video showcase.



MODEL # M5300

PANAMAX
The Surge Protection Specialist

PANAMAX, the Panamax logo and MAX are registered US trademarks of Panamax.
Protect or Disconnect, SurgeGate Plus and SignalPerfect are trademarks of PANAMAX.
SIDACTor is a registered US trademark of Teccor Electronics, Inc. TiVo is a trademark of TiVo, Inc.

© 2001 PANAMAX CORP. All Rights Reserved.

TABLE OF CONTENTS

Before You Begin.....	1	Voltage Sense Trigger.....	8
Introduction.....	2	Circuit Breaker.....	9
Connection Diagram.....	3	Coaxial Line Protection.....	9
Feature Overview.....	4	Telephone Line Protection.....	9
Feature Details		AC Surge Protection.....	10
Voltmeter.....	5	SurgeGate Plus™ Protection.....	10
Convenience Outlet.....	5	Technical Specifications.....	11
Diagnostic Lights.....	6	Contacting Panamax.....	11
Sequential Startup/Shutdown.....	6	Frequently Asked Questions.....	12
Filtered Outlet Banks 1 & 2.....	7		
High-Current Outlet Bank.....	8		

BEFORE YOU BEGIN

Items included with the MAX® 5300:



1 - MAX®5300



4 - Coax Cables for Satellite TV, Cable TV and/or Antennas



1 - RJ-11 Telephone Cable



1 - IEC 320, 120V/15A detachable 10 ft. power cord

Please verify that you have received all these items. If not, contact Panamax.

INTRODUCTION

Your Audio/Video components are constantly being bombarded by electromagnetic interference (EMI) and radio frequency interference (RFI) through their power cords. This contaminated power can affect A/V equipment and will degrade the overall performance of your entire system. Common symptoms of contaminated power include pops, hisses, hums, visual artifacts, etc. Most power filtering devices will remove some of this interference but don't provide a real solution to the problem.

The MAX® 5300 Sophisticated Filtration System is a Real Solution!

Outlet Banks 1 & 2:

The primary filtration system features two banks of independently filtered outlets (4 per bank) for A/V equipment. These outlet banks utilize "Balanced Double L" filter circuits which are far superior to any other design in filtering out all forms of electromagnetic and radio frequency interference in both common and normal modes. Cross-contamination between your components is also eliminated with this design. Bank 1 is Always-On, providing continuous power for those components that have programmable memory settings. Bank 2 can be set to either Always-On or switched with a shutdown delay.

High-Current Outlet Bank:

The unique power requirements of current hungry components such as amplifiers and powered subwoofers are also addressed. These components can rapidly draw large amounts of current to replenish their power supply capacitors after thunderous bass notes. Line conditioners that utilize coils (inductors) in series with the AC power line can "choke" off this large inrush current, thereby reducing the amplifiers' ability to operate at peak performance levels, resulting in a flat, dead sound. The MAX® 5300 high-current outlets are fed by noise filtration circuitry that does not utilize coils and provides full, unimpeded power for your amplifiers and powered subwoofers.

Other Features Enhance the Functionality:

Although the MAX® 5300 functionality revolves around noise filtration and power protection, many other exciting features enhance the overall entertainment experience, including:

- A backlit analog voltmeter indicates the AC line voltage coming into your system.
- A combination ON/OFF/Dimmer switch controls the meter lighting.
- An always-on, convenience outlet on the front panel for temporary AC connections.
- Sequential start-up and shut-down of your system using an A/V receiver (or other component) and the 12VDC trigger input.

As you read through the rest of this manual, you'll discover many more unique features. As audiophiles, we care about the quality of your listening and/or viewing experience. Our goal is to:

- Provide clean pure power
- Protect your investment
- Enhance the pleasure you get from you're A/V system

Thank you for choosing Panamax for your power quality needs. Please finish reading the instructions, install your MAX® 5300 and enjoy the full potential of your entertainment system.

CONNECTION DIAGRAM

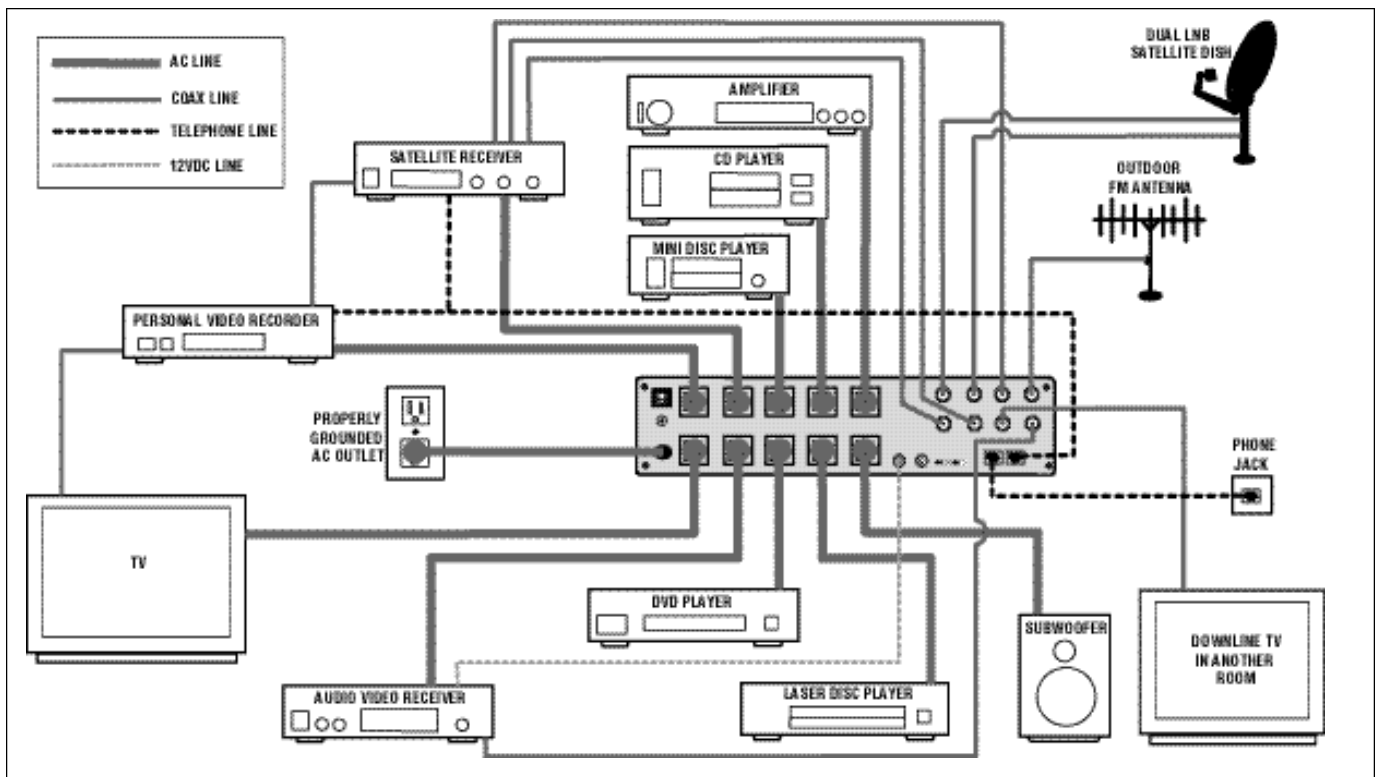

Multi-level noise filter and power controller

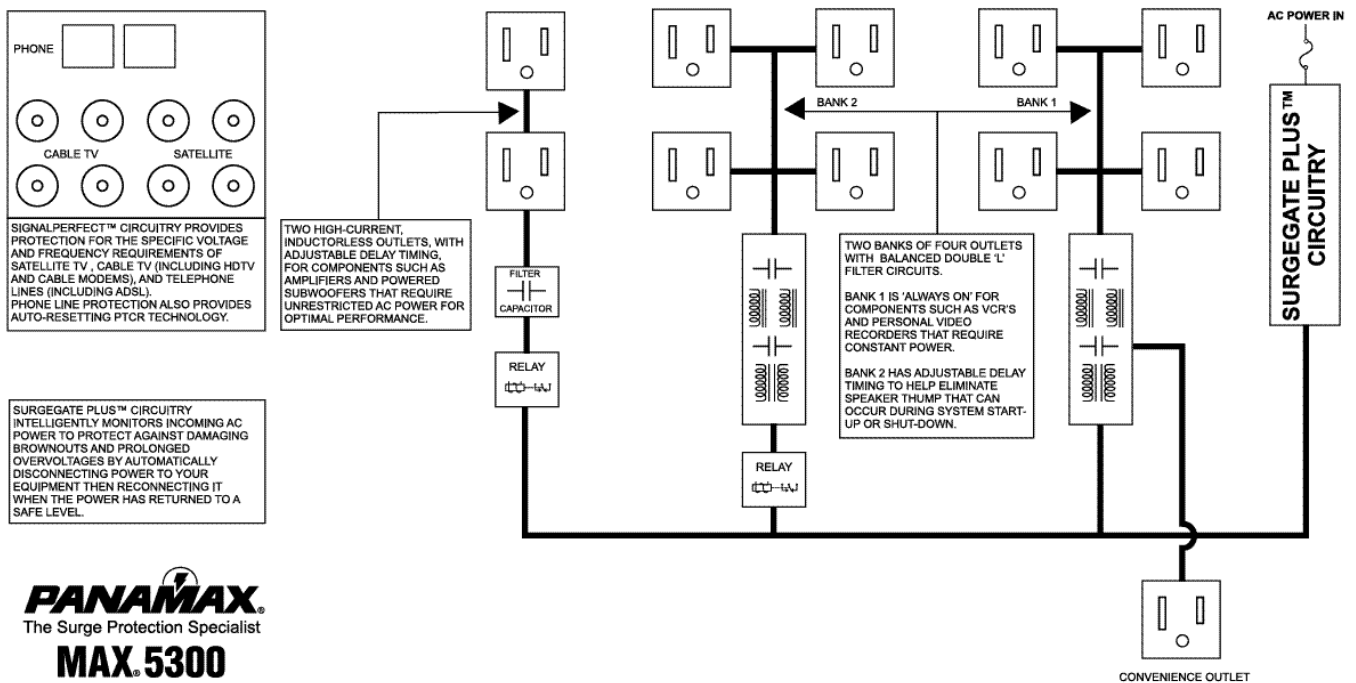

FEATURE OVERVIEW

Switched Outlets Pushbutton:

1 of 2 Triggers that can activate a turn-on or shutdown sequence for Outlet Bank 2 and High-Current outlets.

LED Indicators:

Status indicator lights for Switched Outlets, DC Voltage Trigger, Ground OK, Line Fault and Unsafe Voltage

Meter Light Dimmer:

Controls brightness of the Voltmeter backlighting.

Voltmeter:

Backlit analog meter measures incoming voltage source from 0-150 VAC.

Convenience Outlet:

Provides a quick convenient way to plug in components such as camcorders and video game systems.



15A Circuit Breaker:

Opens in the event that equipment plugged into the MAX® 5300 draws too much current. When the white button of the breaker is visible, the breaker has opened. Reduce the load and push to reset.

Filtered Outlet Bank 1:

Four Always-On, Balanced Double L filtered outlets for audio/video components that require constant power to maintain programmed settings.

Filtered Outlet Bank 2:

Four switched, Balanced Double L filtered outlets for audio/video components that do not require constant power.

High Current Outlet Bank:

Two delayed outlets designed for high-current components such as amplifiers and powered subwoofers. The current available to connected equipment is not limited by the noise filtration components.

Satellite Coax Jacks:

Two pairs of gold plated F-Connectors optimized for Satellite TV signal line protection.

Cable TV Coax Jacks:

Two pairs of gold plated F-Connectors optimized for Cable TV and non-amplified Rooftop Antenna signal line protection.

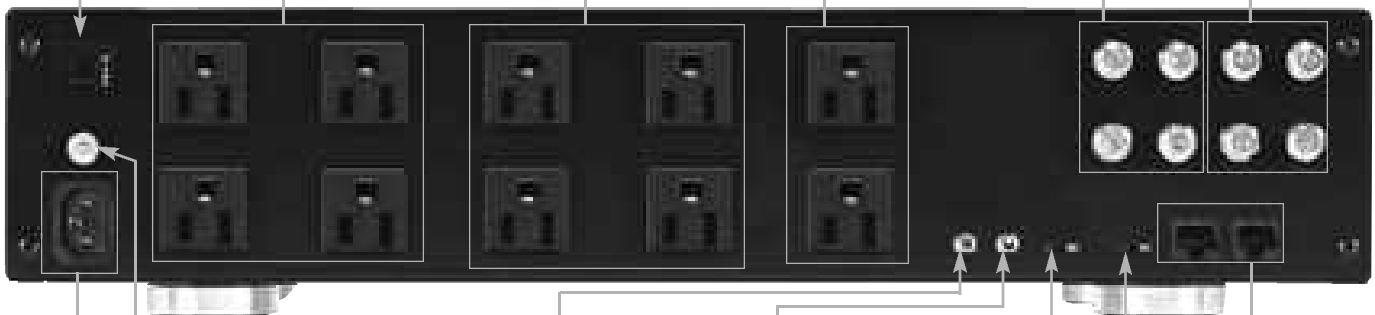

IEC Main Power Receptacle:

Detachable power cord connects to this receptacle.

Ground Lug:

Provides a common grounding point for equipment with separate ground leads.

Voltage Sense Trigger Input:

1/8 inch Mini-Plug jack. Connect to a remote trigger device that provides 12VDC to trigger a startup/shutdown sequence. This is the second trigger that will activate the MAX® 5300 turn-on or shutdown sequence. (See switched outlets pushbutton on front panel).

Voltage Sense Trigger Output:

1/8 inch Mini-Plug jack. Connecting a 12VDC trigger to the Voltage Sense Circuit will allow the same signal to pass through the Voltage Sense Output to control the startup/shutdown of an additional device.

High Current Outlets Turn-On Switch:

3-position slide switch. Allows adjustment of the Turn-On delay for the two High-Current Outlets. Choose between 0, 10 and 30 seconds.

Outlet Bank 2 Turn-Off Switch:

3-position slide switch. Allows adjustment of the Turn-Off delay for Outlet Bank 2. Choose between Always-On, 10 and 30 seconds.

Telephone Jacks:

In/Out connections for telephone line or pay-per-view line protection.

FEATURE DETAILS



Voltmeter

The analog Voltmeter is backlit to provide the ability to view the reading in a dark room. LEDs (light emitting diodes) are used as the light source in order to provide durability and long life. The "Meter Light" dimmer controls the brightness level, or turns the lighting off altogether.

The Voltmeter monitors the incoming voltage from the wall receptacle and provides a visual representation of the available power. The voltmeter is always on and indicates the incoming line voltage even during an unsafe voltage condition. Readings above 150VAC will not be accurate due to the meter's damping characteristics.



Convenience Outlet

A single outlet on the front panel of the MAX[®] 5300 provides an easy to reach power source for electronic equipment typically used on a part time basis. Such equipment includes anything from video game systems to camcorders.

The convenience outlet not only provides superior surge suppression, but also taps into one of the Balanced Double L Filter Circuits to provide clean power for your sensitive electronic equipment. This outlet is an Always-On outlet and will continually supply a steady source of power for your connected equipment. *It is important to remember that power will be disconnected only in the event of an unsafe voltage condition.*

FEATURE DETAILS



Diagnostic Lights

The MAX® 5300 is loaded with special features to save your connected equipment from many different forms of dangerous power disturbances. Five diagnostic lights on the front panel inform you in the event of a power disturbance or when a special feature is activated. The indicators are:



Switched Outlets: Green LED. This light indicates the status of the “Switched Outlets” pushbutton on the front panel and corresponds with the switch position. When the button is in the “ON” position, the light is ON. When the button is in the “OFF” position, the light is OFF. “Switched Outlets” refers to Outlet Bank 2 and the High-Current Outlets. See their respective sections for switching options.



DC Voltage Trigger: Green LED. This light indicates status of the DC voltage trigger on the back panel of the MAX® 5300. The light is ON when the DC voltage trigger is activated and OFF when the DC voltage trigger is not receiving a signal. This light will also be ON if nothing is plugged into the DC voltage trigger input jack. This indicates that the DC voltage trigger is being bypassed.



Ground OK: Green LED. When this light is ON, it indicates that the wall outlet is properly wired. When the light is OFF, it indicates that the wall outlet has reversed line and neutral wires, or that there is no ground present.



Line Fault: Red LED. When this light is ON, it is indicating that the wall outlet has a reversed line and neutral wire, or there is no ground present. This light will remain OFF if the wall outlet is properly wired.



Unsafe Voltage: Red LED. Under normal voltage conditions, this light stays OFF. When this light is FLASHING slowly (once per second), it indicates an undervoltage (<90 VAC) or overvoltage (>132VAC) condition. When the light is flashing quickly (4 times per second), it indicates a 10 second recovery period from an under/overvoltage condition. This light will flash quickly when the MAX® 5300 is first plugged into the wall outlet.

Sequential Startup/Shutdown

Complex audio/video systems may be susceptible to voltage transients generated internally at start-up/shutdown if all of the equipment is powered on or off at the same time. This can cause speaker “thumps” which are not only annoying but can also damage the speakers. The MAX® 5300 is designed to eliminate these transients by providing a “start-up” delay for the High-Current outlets and a “shutdown” delay for Outlet Bank 2. This allows the components plugged into the switched outlets to power-up and stabilize before any amplifiers and powered sub-woofers are turned on. This sequence is reversed during shutdown. The amplifiers and powered sub-woofers turn off, their power supplies drain, then the equipment plugged into Outlet Bank 2 is turned off.

Information on setting the delay times is included in the [Outlet Bank 2](#) and [High Current Outlet Bank](#) sections that follow.

FEATURE DETAILS

Filtered Outlet Banks 1 & 2:

Eight Outlets (two banks / four outlets per bank) are fed through separate "Balanced, Double L" noise filtration circuits. These circuits are designed to eliminate AC contamination that is detrimental to the performance of audio or video components like stereo receivers, VCRs or televisions. The two dedicated filters are carefully engineered to provide power filtration and inter-component "noise isolation" for both "common mode" (line/neutral-to-ground) and "normal-mode" (line-to-neutral) EMI/RFI. This means that high-frequency interference will be drastically reduced not only from the incoming power but also from equipment plugged into the other outlet bank, regardless of what "mode" it occurs in. Even equipment with ungrounded, 2-blade plugs, receives clean power.



Outlet Bank 1 remains ON continually to provide a constant power source for programmable audio/video components. A personal video recorder (such as TiVo™) and VCR are two examples of components that require a constant supply of power. A TiVo™ video recorder relies on continual power to monitor the cable signal and retain its programmed information. A VCR should be connected to one of these always-on, filtered outlets to maintain correct clock time and programmed recording information.

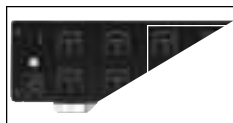

Outlet Bank 2 contains four switched outlets that will turn your connected equipment ON or OFF with one of two MAX® 5300 triggers (Switched Outlets push-button or Voltage Sense Trigger). A 3-position slide switch (Outlet Bank 2 Turn-Off Switch) located on the rear panel controls the timing for Outlet Bank 2. Together, these outlets can be set as Always-On or with a turn-off delay of either 10 or 30 seconds to prevent speaker "thump". This switch provides the option of having a total of eight always-on outlets (Outlet Banks 1 & 2). See the Sequential Startup/Shutdown section for more information.

When set to one of the delay positions (10 or 30 seconds), Outlet Bank 2 outlets will remain as Switched outlets, controlled by the Switched Outlets push-button and/or the DC Voltage Sense Trigger. In this situation, Outlet Bank 2 outlets will not power down until after the selected time has elapsed.

FEATURE DETAILS

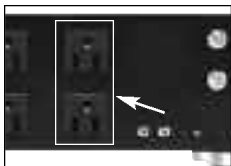

High-Current Outlet Bank

The two high-current outlets allow amplifiers and powered subwoofers to work to their full potential. When the movie thunders with a terrific explosion or when the music reaches a climactic crescendo, an amplifier has to rapidly draw large amounts of current to replenish its power supply capacitors. Traditional line conditioners impede this current draw, in effect, starving an amplifier and resulting in a flat, dead sound. The High-Current Outlet Bank provides clean, filtered power to amplifiers but has no current limiting components to impede performance.

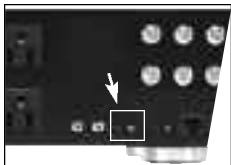

The high-current outlets are designed with a turn-on delay option of 0, 10 or 30 seconds. The 3-position, Delayed Outlet Turn-On Switch on the back of the MAX® 5300 is used to select the desired time delay. When a delay is selected, the high-current outlets will turn-on after Outlet Bank 2 and turn-off before Outlet Bank 2 (if they're not set to Always-On). With a delay, the connected equipment will not power up simultaneously, thus preventing loudspeaker noises such as "thumping". See the **Sequential Startup/Shutdown** section for more information.

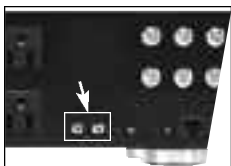

Voltage Sense Trigger

This feature provides an ON/OFF trigger for the MAX® 5300 using a 12VDC remote control signal. Many components such as pre-amplifiers and receivers have a 12VDC trigger built in, and will transmit a constant power signal when turned on and in use. This power signal will initiate the startup or shutdown sequence of the MAX® 5300's switched outlets. An AC Adapter of the appropriate voltage, plugged into a switched outlet, may also be used if a 12V trigger is not built in.

The MAX® 5300 voltage sense trigger input uses a standard 1/8" mini-plug jack. This jack has an electrically isolated switch built in. If nothing is inserted into the input jack, the voltage sense is bypassed and the MAX® 5300 Switched Outlets button on the front panel has sole control of the startup/shutdown sequence. If a plug is inserted into the input jack, the voltage sense becomes the startup/shutdown trigger. *Please note: The Switched Outlets pushbutton on the front panel must be left in the "ON" position if you are using the DC trigger.*

The circuitry for the voltage sense trigger also controls the DC Voltage Trigger diagnostic LED on the front panel. When a 1/8" mini-plug is connected to the voltage sense input jack and a DC voltage signal is present, the LED will light to indicate that the voltage sense circuit is ON and the MAX® 5300's switched outlets are ON. When the diagnostic light is not lit, the source component is turned off and there is no DC signal.

The MAX® 5300 also has the ability to pass through the DC signal from the voltage sense trigger to another slave device. *Please note: The Voltage Sense Trigger Output will not operate unless the Voltage Sense Trigger Input is connected to a source.*

FEATURE DETAILS

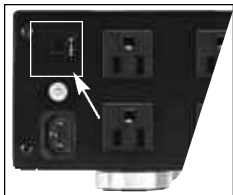

Circuit Breaker

A circuit breaker is located on the back panel of the MAX@5300. The circuit breaker will trip only if the total current draw exceeds the maximum current rating (15A). This means that collectively, all outlets must draw more than 15 Amps before the circuit breaker will trip.



SignalPerfect™ Coaxial Line Protection

All coaxial cable sheaths from outdoors must be grounded to the building grounding electrode system where they enter the building (per applicable NEC/CEC code). A driven ground rod is not adequate.

Panamax's exclusive SignalPerfect™ Technology provides application-specific protection for your satellite and cable TV equipment. Two lines of protection are provided for each type. The satellite connections are for coaxial cables connected to a DBS (single or dual LNB) satellite dish. The antenna connection is for a non-amplified rooftop antenna or cable TV line. The Additional TV connection protects the equipment plugged into the MAX@ 5300 from "backdoor" surges in situations where the video signal runs to another room for a downline TV.

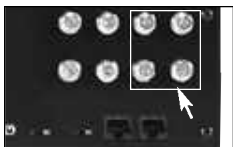

Cable TV (Including HDTV) – TV tuners operate at approximately 10 millivolts (0.01 V) and utilize the frequency spectrum of 50Mhz to 950Mhz. The clamping level of the MAX@ 5300's cable TV protection circuitry is 700 millivolts (0.7 volts). That's less than 1 volt above normal operating levels. The circuitry is shielded to prevent interference and has been optimized to have less than 1dB of signal loss throughout the entire 50Mhz to 950Mhz range.

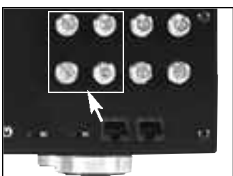

Satellite - Satellite dish LNB's can require up to 24 volts to operate and utilize the frequency range of 950Mhz to 2.2Ghz. The clamping level of the MAX@ 5300's satellite protection circuitry is 27 volts - just 3 volts above the maximum operating voltage. The circuitry is shielded to prevent interference and has been optimized to have less than 1dB of signal loss throughout the entire 950Mhz to 2.05Ghz range and less than 2.4db up to 2.2Ghz.



SignalPerfect™ Telephone Line Protection

Satellite TV receivers require a telephone line connection for Pay-Per-View services. The MAX@ 5300 also provides surge protection for this line. One pair of RJ-11/45 compatible telephone jacks is provided for this. The circuitry utilizes auto-resetting PTCRs and solid-state SIDACTors™ for reliability and unsurpassed protection. The clamping level of the MAX@ 5300's telephone protector is 260 volts. This will allow typical ring voltage (90-130VAC) and operating battery voltage (-48DC) to pass through the circuit and still protect the modem in your satellite receiver from damage.

Please note: The protection circuitry will not work if the phone lines are reversed. The incoming phone cable must be connected to the "LINE" jack and the cable to the audio/video equipment must be connected to the "EQUIP" jack.

FEATURE DETAILS

The MAX® 5300 provides protection against common problems on the AC power line. This includes spikes/surges and sustained overvoltages or undervoltages. Panamax's exclusive Protect or Disconnect™ circuitry is designed to protect against spikes/surges while the SurgeGate Plus™ circuitry is for sustained over/under voltage protection.

Protect or Disconnect™ AC Surge Protection



1. Voltage reaches an unsafe level.
2. If surge is greater than MAX® 5300 capacity, it **disconnects**.

When the MAX® 5300 is subjected to a high voltage surge, its voltage output is limited to a safe level and the high levels of surge current are diverted away from the connected equipment.

- When subjected to a 6,000V (open circuit voltage) / 500A (short circuit current) surge, the MAX® 5300 limits its voltage output to less than 330V peak, UL's lowest rating. The MAX® 5300 will withstand, without damage, multiple 12,000A surges, far exceeding the UL maximum requirement of only 3,000 Ampere surges.
- If the magnitude of the surge is greater than the capacity of the surge protection components, the MAX® 5300's Protect or Disconnect™ Circuitry will disconnect your equipment in order to protect it. The MAX® 5300 will need to be repaired or replaced by Panamax if this occurs.

SurgeGate Plus™ Protection



1. Voltage reaches an unsafe high level and the SurgeGate Plus™ **disconnects**.
2. Voltage reaches a safe level and SurgeGate Plus™ automatically **reconnects**.
3. Voltage reaches an unsafe low level and SurgeGate Plus™ **disconnects**.
4. Voltage reaches a safe level and SurgeGate Plus™ automatically **reconnects**.

The MAX® 5300 constantly monitors the AC line voltage for unsafe voltage conditions such as prolonged overvoltages and undervoltages (brownouts). These unsafe conditions pose a very dangerous threat to all electronic equipment within the home. If the MAX® 5300 senses an unsafe power condition, it will automatically **disconnect** your equipment from the power to protect equipment from damage. Once the voltage returns to a safe level, the MAX® 5300 will automatically **reconnect** the power.

If the line voltage exceeds the overvoltage threshold (132VAC) or falls below the undervoltage threshold (90VAC), the MAX® 5300 will perform the following tasks until line voltage returns to a safe level:

1. Disconnects power to all connected equipment.
2. Unsafe Voltage LED is activated and will blink once per second during the unsafe voltage condition.

The MAX® 5300 requires line voltage to return to within the safe operating range for 10 seconds before returning to normal operating mode. This is referred to as "Over/Undervoltage Recovery". The safe operating range is considered 5V above the under-voltage threshold (~95V) and 5V below the overvoltage threshold (~127V). Once this safe operating range is reached, the MAX® 5300 will perform the following functions:

1. Unsafe Voltage LED will blink 4 times per second for Over/Undervoltage Recovery.
2. Power is restored to all connected equipment after the 10-second delay. The normal start-up sequence as determined by the "High-Current Outlets Turn-On Switch" and "Outlet Bank 2 Turn-Off Switch" will be followed.



TECHNICAL SPECIFICATIONS

GENERAL	
Dimensions.....	17.25" W x 12" D x 3.5" H
Weight.....	16 lbs.
AC CIRCUIT	
NOISE FILTRATION:	
Filtered Outlet Banks.....	55 dB (100 KHz - 1 MHz)
High-Current Outlets.....	50 dB (100 KHz - 1 MHz)
SURGE PROTECTION:	
UL 1449 Surge Suppression Rating.....	330V
Protection Modes.....	L - N, L - G, N - G
Initial Clamping Level.....	200V Peak, 141V Rms
Response Time.....	<1ns
Joule Rating.....	1790 Joules
Peak Impulse Current.....	65,000A
Catastrophic Surge Circuit	YES
AC:	
Line Voltage.....	120VAC
Max Current Rating.....	15A (1800 Watts)
Thermal Fuse.....	YES
Over/Under Voltage Protection.....	YES
Over-voltage shutoff threshold.....	132V
Under-voltage shutoff threshold.....	90V

Design and specifications subject to change without notice due to product improvement.

DC TRIGGER	
Connection.....	1/8" mini-plug
Voltage and Polarity.....	12VDC, bi-directional
Current Requirement.....	30mA
SATELLITE CIRCUIT	
Clamping Level.....	27V
Attenuation.....	<1 dB from 950MHz - 2.05GHz <2.4 dB up to 2.2GHz
Shielded.....	YES
Connections.....	Gold plated, Female "F"
ANT/CATV CIRCUIT	
Clamping Level.....	0.7V
Attenuation.....	<1 dB from 50MHz -950MHz
Shielded.....	YES
Connections.....	Gold plated, Female "F"
TELEPHONE CIRCUIT	
Clamping Level.....	260V
Capacitance.....	30pf (approx.)
Suppression Modes.....	Metallic & Longitudinal
Wires Protected.....	2 wire/ 1 pr. (pins 4,5)
Fuseless/Auto-Resetting.....	YES
Connections.....	RJ-11/45

CONTACTING PANAMAX

For product and warranty information, dealer information, and other general information contact Customer Relations at:

- Email: custrelations@panamax.com
- www.panamax.com
- Fax **415-472-5540**
- **800-472-5555** or **415-499-3900**, 7:30 a.m.- 5 p.m. PST

My MAX® 5300 power cable does not reach the wall outlet. Can I use an extension cord to make it reach?

Yes, but you must use only Panamax extension cords to keep your warranty valid. Ask for part # GEC1410.

The provided coax or telephone jumper cables are not long enough to reach my equipment. Can I use other cables?

Yes, any length cable of the same type meets the warranty requirements.

Outlet Bank 2 is not switching ON or OFF with the MAX® 5300. How can I fix this?

These outlets may be set as either switched or Always-On outlets. The 3-position, Turn-Off Delay switch on the back panel controls this. Change the setting of this switch from Always-On to a delayed setting. This will allow the Outlet Bank 2 to become switched outlets.

The MAX® 5300 is ON but the Voltmeter is not lit up. What is the problem?

Check the Meter Light Dimmer control to see if the lighting is turned ON or OFF. If the control knob is turned OFF, turn it ON and continue turning until you have reached the desired light level. If the control knob is turned ON and there is no light, turn the knob to maximum. If you still have no light, call Panamax Customer Service for help.

There was a lightning strike in my neighborhood and now my MAX® 5300 won't turn on. What is wrong?

The Protect or Disconnect™ circuitry has done its job and protected your equipment from the lightning by sacrificing itself. Your MAX® 5300 will need to be repaired or replaced. Please refer to the preceding section on "Contacting Panamax" or the warranty documentation for more information.

What is the difference between a Surge and Spike?

A spike is a high-energy pulse of electricity that lasts for short periods of time (a few milliseconds, 0.001 second) but can reach up to 6000 volts or higher. Nearby lightning strikes and ESD (Electrostatic Discharge) are the cause for most power spikes. A surge is similar to a spike, but will last for longer periods of time (15 milliseconds to 2.5 seconds) and reach up to 500 volts. Utility grid switching and motors turning on or off cause most power surges. Both surges and spikes are damaging to sensitive solid-state components present in Audio/Video equipment.

What is the difference between an Overvoltage and Undervoltage?

An overvoltage happens when power rises to an unsafe level (over 150 volts) for a long period of time (2.5 seconds to several hours). Overvoltages are usually caused by car accidents involving power poles, construction wiring accidents, wind and ice storms. An undervoltage (brownout) happens when power drops to an unsafe level (under 80 volts) for a long period of time (2.5 seconds to several hours). Undervoltages are usually caused by failures in the electric utility system or by very heavy power demands during a hot day. Both overvoltages and undervoltages will damage Audio/Video equipment power supplies.

What Does EMI and RFI stand for?

RFI (Radio Frequency Interference) and EMI (Electromagnetic Interference) refer to high frequency signals emitted through the air and induced into AC power lines. Audio/Video equipment will pick up these signals and generate enough noise to degrade picture and sound quality.

PANAMAX
The Surge Protection Specialist

Download from www.Somanuals.com All Manuals Search And Download.

USA & Canada (800) 472-5555 • (415) 499-3900 • www.panamax.com

PANAMAX SURGE PROTECTOR WARRANTY

Panamax warrants to the purchaser of this Panamax audio/video component style surge protector, for a period of three (3) years from the date of purchase, that the surge protector shall be free of defects in design, material, or workmanship, and Panamax will repair or replace any defective unit. For product replacement see "NOTIFICATION" below.

Warning Notice

CAUTION: Audio/Video, computer and/or telephone system installations can be very complex systems which consist of many interconnected components. Due to the nature of electricity and surges, a single protector may not be able to completely protect complex installations. In those cases, a systemic approach using multiple protectors must be employed. Systemic protection requires professional design. AC power, satellite cables, CATV cables, or telephone/network lines entering the system that do not pass through this surge protector will render the Panamax connected equipment protection policy null and void. For information on how to protect your system, please contact Panamax before connecting your equipment to the surge protector.

More detailed information is available at
www.Panamax.com

If you have any questions regarding these requirements, please contact Panamax Customer Relations.

PANAMAX SURGE PROTECTOR CONNECTED EQUIPMENT PROTECTION POLICY

Valid only in the United States and Canada

It is the policy of Panamax that it will, in its sole discretion, replace, pay to replace at fair market value, or pay to repair, up to the dollar amount specified below, equipment that is damaged by an AC power, cable, telephone, or lightning surge while connected to a properly installed Panamax surge protector. Panamax must determine that the surge protector shows signs of surge damage or is operating outside of design specifications, relative to its surge protection capability, and under all of the circumstances failed to protect your connected equipment.

MAX® 2100: \$5,000,000 MAX® 5100: \$5,000,000
MAX® 5300: \$5,000,000 MAX® 5500: \$5,000,000

THIS POLICY IS SUBJECT TO THE CONDITIONS BELOW:

1. PROOF OF PURCHASE REQUIRED: Panamax's connected equipment policy extends to the original purchaser only and is non-transferable. Original purchase receipts must accompany any product return or claim for connected equipment damage.

2. PROPER INSTALLATION: Panamax AC protectors must be directly plugged into a properly grounded 3-wire AC outlet. Extension cords, non-grounded two prong adapters, or other non-Panamax surge products must not be used.* Building wiring and other connec-

tions to protected equipment must conform to applicable codes (NEC or CEC). No other ground wires or ground connections may be used. All wires (including, e.g., AC power lines, telephone lines, signal/data lines, coaxial cable, antenna lead-ins) leading into the protected equipment must first pass through a single Panamax protector designed for the particular application. The protector and the equipment to be protected must be indoors in a dry location, and in the same building. Panamax installation instructions and diagrams must be followed.

3. NOTIFICATION: You must notify Panamax within ten days of any event precipitating a request for product replacement or payment for connected equipment damage. A return merchandise authorization (RMA) number must first be obtained from the **Panamax Customer Relations Department** at www.panamax.com/support or toll-free at **1-800-472-5555** before returning the protector to Panamax. At this time, you must notify Panamax if you believe you have a claim for damaged connected equipment.

Once you obtain an RMA number, please mark the number on the bottom of the unit and pack it in a shipping carton/box with enough packing material to protect it during transit. The RMA number must also be clearly marked on the outside of the carton. Ship the unit to Panamax. Please note that you are responsible for any and all charges related to shipping the unit to Panamax.

4. DETERMINATION OF FAILURE: Panamax will evaluate the protector for surge damage. The Panamax protector must show signs of surge damage or must be performing outside (>10%) of design specifications relative to its surge protection capability. Opening the enclosure, tampering with, or modifying the unit in any way shall be grounds for an automatic denial of your request for payment. Panamax, after evaluating all information provided, shall, in its sole discretion, determine whether or not your request is eligible for payment.

If the surge protector shows no signs of AC power or signal line surge damage and is working within design specifications, Panamax will return the unit to you with a letter explaining the test results and notifying you of your claim's rejection.

If the surge protector shows signs of AC power or signal line surge damage, Panamax will forward to you a claims kit to be completed and returned within 30 days. Before disconnecting your system, please take note of its configuration, because a connection diagram of your system will be required as part of the returned claim kit.

Panamax reserves the right to inspect the damaged connected equipment, parts, or circuit boards. Please note that you are responsible for any and all charges related to shipping the damaged equipment to Panamax. Panamax also reserves the right to inspect the customer's facility. Damaged equipment deemed uneconomical to repair must remain available for inspection by Panamax until the claim is finalized.

5. REQUEST PAYMENTS: Once Panamax has determined that you are entitled to compensation, Panamax will, at its election, pay you the present fair market value of the damaged equipment, or pay for the cost of the repair, or send you replacement equipment.

6. OTHER INSURANCE/WARRANTIES: This coverage is secondary to any existing manufacturer's warranty, implied or expressed, or any insurance that may cover the loss and/or service contract in existence at the time of the loss.

7. EXCLUSIONS: THE PANAMAX CONNECTED EQUIPMENT PROTECTION POLICY DOES NOT APPLY TO: Service charges, installation costs, reinstallation costs; setup cost; diagnostic charges; periodic checkups; routine maintenance; loss of use of the product; costs or expenses arising out of reprogramming or loss of programming and/or data; shipping charges or fees; service calls; loss or damage occasioned by fire, theft, flood, wind, accident, abuse or misuse, and products subject to manufacturer's recall or similar event.

8. DISPUTE RESOLUTION: Any controversy or claim arising out of or relating to Panamax's Connected Equipment Protection Policy, or the alleged breach thereof, shall be settled by arbitration administered by the American Arbitration Association under its Commercial Arbitration Rules. You may file for arbitration at any AAA location in the United States upon the payment of the applicable filing fee. The arbitration will be conducted before a single arbitrator, and will be limited solely to the dispute or controversy between you and Panamax. The arbitration shall be held in any mutually agreed upon location in person, by telephone, or online. Any decision rendered in such arbitration proceedings will be final and binding on each of the parties, and judgement may be entered thereon in a court of competent jurisdiction. The arbitrator shall not award either party special, exemplary, consequential, punitive, incidental or indirect damages, or attorney's fees. The parties will share the costs of arbitration (including the arbitrator's fees, if any) in the proportion that the final award bears to the amount of the initial claim.

9. GENERAL: If you have any questions regarding the product warranty or the connected equipment protection policy, please contact the **Panamax Customer Relations Department** at www.panamax.com/support or toll-free at **1-800-472-5555**. This warranty supersedes all previous warranties. This is the only warranty provided with the protector and any other implied or expressed warranties are non-existent. This warranty may not be modified except in writing, signed by an officer of the Panamax Corporation.

*The use of a Panamax extension cord (part # GEC1410) will not invalidate the warranty.

**Forms are available on the Panamax web site for requesting RMAs and opening a claim for connected equipment damage.

Effective Date 06/01

Q01L0037 Rev. B

IWS5500 Rev. B

Free Manuals Download Website

<http://myh66.com>

<http://usermanuals.us>

<http://www.somanuals.com>

<http://www.4manuals.cc>

<http://www.manual-lib.com>

<http://www.404manual.com>

<http://www.luxmanual.com>

<http://aubethermostatmanual.com>

Golf course search by state

<http://golfingnear.com>

Email search by domain

<http://emailbydomain.com>

Auto manuals search

<http://auto.somanuals.com>

TV manuals search

<http://tv.somanuals.com>