

M2-AV Installation Instructions

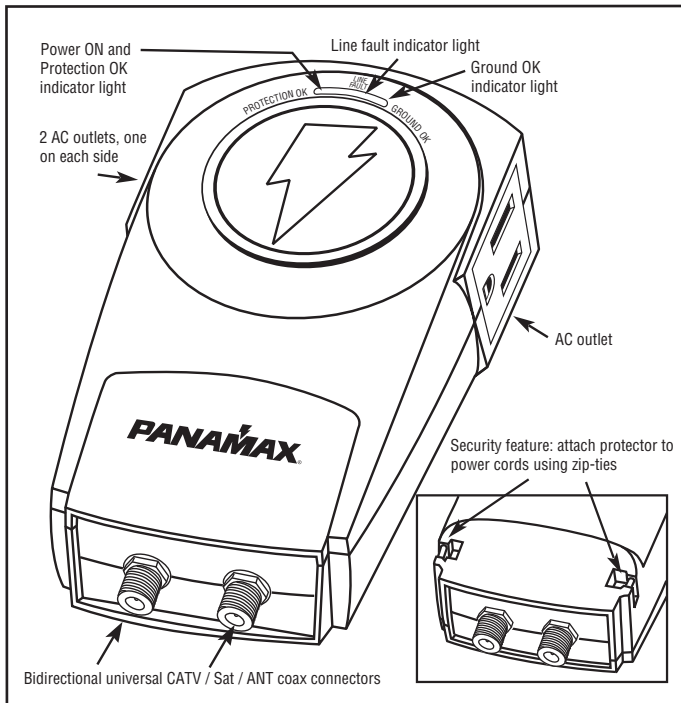

Quick Start

1. Plug the surge protector into the wall outlet. A green "**Ground OK**" light indicates proper wiring. A red "**Line Fault**" light indicates an improperly wired outlet that must be checked by a qualified electrician.
2. If the green "**Ground OK**" light is on, plug your equipment into the AC outlets on the surge protector.
3. Turn the connected equipment ON and check for power and correct operation.
4. For satellite, CATV or cable modem connections: The protection circuitry is bi-directional; line and equipment cables may be attached to either connector.
5. Equipment cords may be secured to the bottom of the surge protector using standard zip-ties.

FOR PROPER PRODUCT INSTALLATION, STABILITY BUMPER SHOULD NOT BE IN CONTACT WITH THE RECEPTACLE COVER PLATE.

PANAMAX
CUSTOMER SUPPORT:
800-472-5555

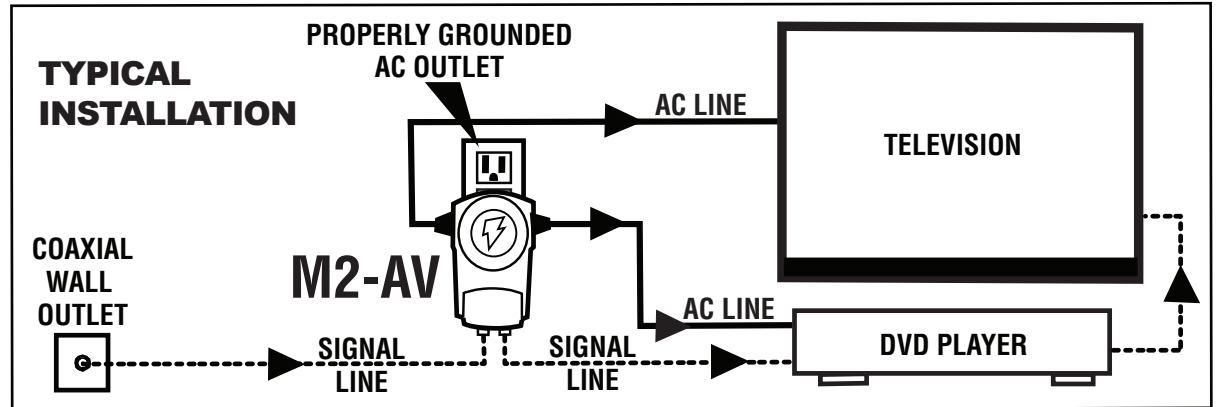

Overview

The M2-AV provides surge and over-voltage protection for satellite receivers, cable televisions, cable modems, and all AC-only electronic devices.

The M2-AV is equipped with 2 AC outlets. It also features Panamax's exclusive Protector Disconnect™ circuitry which handles an unlimited number of surges and will disconnect the power during a catastrophic surge to keep your equipment safe.

In addition, the M2-AV has 3 diagnostic lights for maximum safety. They are designated as follows:

1. **GroundOK** – (green) normally ON - indicates that the wall outlet is properly grounded.
2. **LineFault** – (red) normally OFF - when lit, indicates that the wall outlet is improperly wired.
3. **Power ON / Protection OK** - (green) normally ON - indicates that the power is on, surge protector is functioning properly, and all connected equipment is protected.

Full protection and proper operation occurs when two green lights are lit.

Properly Connecting Your Surge Protector

To completely protect your equipment from power surges, every wire leading into or out of the equipment you want to protect must be connected to the appropriate Panamax surge protector. Damaging lightning and power surges can get into your system through any AC power or signal line (phone lines, grounding wires, coax cables, modem cables, etc.) connected to your electrical equipment.

The \$5,000,000 Connected Equipment Protection Policy is invalid if anywire leading into or out of the equipment is not properly connected to the appropriate Panamax surge protector(s). The surge protector must also be plugged into a properly wired and grounded outlet. Please see the warranty for details or contact the Panamax Customer Service department with questions.

Important Safety Point

Panamax surge protectors and the connected equipment must be indoors in a dry location and in the same building. Do not install any Panamax product near heat emitting appliances such as a radiator or heat register.

Do not install this product where excessive moisture is present; for example, near a bathtub, sink, pool, basement floor, fishtank, etc.

It is not uncommon for a building to be improperly grounded. In order to protect your equipment, and validate the warranty, Panamax products must be plugged into a properly grounded 3-wire outlet.

Additionally, building wiring and grounding must conform to applicable NEC (USA) or CEC (Canada) codes for the Panamax warranty to be valid.

Do not use 2-prong adapters with this product. If an extension cord is required, use only a Panamax extension cord. If at any time your surge protector indicates a Line Fault, call your electrician to correct the building wiring.

Note to CATV/SAT Installers

This reminder is provided to call the CATV System Installer's attention to Article 820-40 of the NEC that provides specific guidelines for proper grounding and, in particular, specifies that the cable ground shall be connected to the grounding system of the building, as close to the point of cable entry as practical. A separate driven ground rod is not acceptable under the code.

Free Manuals Download Website

<http://myh66.com>

<http://usermanuals.us>

<http://www.somanuals.com>

<http://www.4manuals.cc>

<http://www.manual-lib.com>

<http://www.404manual.com>

<http://www.luxmanual.com>

<http://aubethermostatmanual.com>

Golf course search by state

<http://golfingnear.com>

Email search by domain

<http://emailbydomain.com>

Auto manuals search

<http://auto.somanuals.com>

TV manuals search

<http://tv.somanuals.com>