

Panasonic

Telephone Answering System
with Facsimile

Model No.

KX-F880

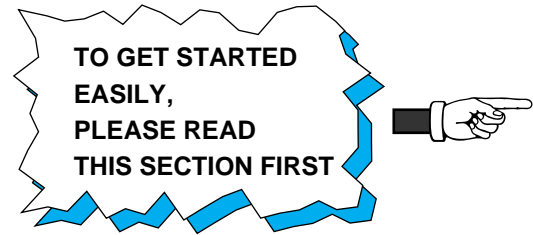

OPERATING INSTRUCTIONS



Please read these Operating Instructions before using the unit and save for future reference.

**FOR OPERATION ASSISTANCE,
CALL 1-800-HELP-FAX (1-800-435-7329)**

- **This product is designed for use in the United States of America, and may not operate in other countries. (See page 80 for more details.)**
- Este producto ha sido diseñado para su uso en los Estados Unidos de América, y puede no funcionar correctamente en otros países. (Consulte la página 80 para tener más detalles.)

Quick Start

**Advanced
Operations**

Special Settings

**Troubleshooting
and Routine Care**

**General
Information**

Thank you for purchasing the Panasonic Telephone Answering System with Facsimile.

Welcome to the world of Panasonic facsimiles.

This Panasonic Telephone Answering System with Facsimile combines a telephone, fax, copier, and telephone answering system to provide you with more efficient office or home use. By utilizing these convenient features, you can maximize the effectiveness of this unit.

Things you should keep records of

Attach your sales receipt here

For your future reference

Date of purchase _____

Serial No. _____

(found on the bottom of the unit)

Dealer's name and address _____

Dealer's telephone number _____

Caution:

- The Telephone Protection Act of 1991 requires the following information to be clearly stated either at the top or bottom margin of the first message page when transmitting messages via telephone facsimile;
 - Date and time of transmission,
 - Identification of the business, entity or person(s) sending the facsimile, and
 - Telephone number of the business, entity or person(s).

To program this information into your facsimile machine, complete all the instructions on pages 13 through 15.

Copyright:

This manual is copyrighted by Kyushu Matsushita Electric Co., Ltd. (KME) and its licensee. Under the copyright laws, this manual may not be reproduced in any form, in whole or part, without the prior written consent of KME and its licensee.

© Kyushu Matsushita Electric Co., Ltd. 1997

Important safety instructions

When using this unit, basic safety precautions should always be followed to reduce the risk of fire, electric shock, or personal injury.

1. Read and understand all instructions.
2. Follow all warnings and instructions marked on this unit.
3. Unplug this unit from AC outlets before cleaning. Do not use liquid or aerosol cleaners. Use a damp cloth for cleaning.
4. Do not use this unit near water, for example, near a bath tub, wash bowl, kitchen sink, or the like.
5. Place the unit securely on a stable surface. Serious damage and/or injury may result if the unit falls.
6. Do not cover slots and openings on the unit. They are provided for ventilation and protection against overheating. Never place the unit near radiators, or in a place where proper ventilation is not provided.
7. Use only the power source marked on the unit. If you are not sure of the type of power supplied to your home, consult your dealer or local power company.
8. For Safety purposes this product is equipped with a three prong grounded plug. If you do not have this type of outlet, please have one installed. Do not use any type of adaptor plug to defeat this safety feature.
9. Do not place objects on the power cord. Install the unit where no one can step or trip on the cord.
10. Do not overload wall outlets and extension cords. This can result in the risk of fire or electric shock.
11. Never push any objects through slots in this unit. This may result in the risk of fire or electric shock. Never spill any liquid on the unit.
12. To reduce the risk of electric shock, do not disassemble this unit. Take the unit to an authorized servicer when service is required. Opening or removing covers may expose you to dangerous voltages or other risks. Incorrect reassembly can cause electric shock when the unit is subsequently used.
13. Unplug this unit from the wall outlet and refer servicing to an authorized servicer when the following conditions occur:
 - A. When the power supply cord or plug is damaged or frayed.
 - B. If liquid has been spilled into the unit.
 - C. If the unit has been exposed to rain or water.
- D. If the unit does not work normally by following the operating instructions. Adjust only controls covered by the operating instructions. Improper adjustment may require extensive work by an authorized servicer.
- E. If the unit has been dropped or physically damaged.
- F. If the unit exhibits a distinct change in performance.
14. During thunderstorms, avoid using telephones except cordless types. There may be a remote risk of an electric shock from lightning.
15. Do not use this unit to report a gas leak, when in the vicinity of the leak.

SAVE THESE INSTRUCTIONS

INSTALLATION:

1. Never install telephone wiring during a lightning storm.
2. Never install telephone jacks in wet locations unless the jack is specifically designed for wet locations.
3. Never touch uninsulated telephone wires or terminals unless the telephone line has been disconnected at the network interface.
4. Use caution when installing or modifying telephone lines.

WARNING:

To prevent the risk of fire or electrical shock, do not expose this product to rain or any type of moisture.

OTHER INFORMATION

- Keep the unit away from electrical noise-generating devices, such as fluorescent lamps and motors.
- The unit should be kept free from dust, high temperature, and vibration.
- The unit should not be exposed to direct sunlight.
- Do not place heavy objects on top of this unit.
- Do not touch the plug with wet hands.

Table of Contents

Quick Start

Before you start

- Included accessories 6
- Accessory order information 6
- Overview 7

Installation

- Installing the handset cradle 8
- Installing the recording paper 9
- Installing the paper stacker 9
- Connecting the telephone line and the power outlet 10
- Location of controls 11
- Help function..... 12

Initial preparation

- Setting the date and time 13
- Setting your logo 14
- Setting your facsimile telephone number 15

Basic operations

- Making voice calls..... 16
- Answering voice calls <Caller ID capability> 17
- Making a copy 18
- Transmitting documents 19
- Receiving documents (receive mode, etc.) 22
- Operating the answering device 26

Advanced Operations

Special receiving modes

- FAX mode (receiving fax documents only) 29
- TEL/FAX mode (automatic voice and fax recognition)..... 30

Automatic dialing

- Storing phone numbers for automatic dialing 33
- Making voice calls using automatic dialing 34
- Transmitting documents using automatic dialing 34
- Electronic telephone directory (selecting a station name in the directory) .. 35

Telephone

- Voice contact (talking to the caller during or after fax reception or transmission) .. 36
- TONE, FLASH and REDIAL/PAUSE buttons 37

Special sending features

- Polling (retrieving fax documents) 38
- Delayed transmission (sending a fax at a later time) 39

Special receiving features

- Remote fax receiving (using an extension phone to receive a fax message) .. 40
- Junk mail prohibitor (preventing the reception of unwanted fax documents) 42
- Receiving with a distinctive ring service 43

Answering device

- Recording your own greeting messages 44
- Voice mailbox (how callers can leave you private messages) 46
- Transferring incoming call messages 49
- Operating the answering device from a remote phone 51

Special Settings

Summary of user programmable features	56
Setting the ANS/FAX mode ring count.....	57
Setting the FAX mode ring count.....	58
Setting the TEL/FAX mode ring count	58
Setting the silent fax recognition ring count	59
Changing the caller's recording time	59
Changing the logo print position	60
Sending documents overseas	60
Changing the display contrast	61
Setting the message alert	61
Setting the recording time alert	62
Setting the friendly reception	62
Setting the fax voice guidance	63
Changing the recording time for the ANS/FAX greeting message....	63
Signaling your pager that you have received fax document	64
Resetting the advanced features.....	65
Setting the handset switch	65
Printing reports and lists	66

Quick Start

Advanced Operations

Special Settings

Troubleshooting and Routine Care

General Information

Troubleshooting and Routine Care

Troubleshooting

Error messages on the display	70
Before requesting help.....	71
Clearing a recording paper jam.....	73
Clearing a document jam	74
Adjusting the feeder pressure	74

Routine care

Removing the handset cradle	75
Cleaning the inside of the unit	75

General Information

FCC information.....	76
Limited warranty	77
Service center directory.....	78
User information	79
Specifications	80
Speed dialing list	81
Index	83

Before you start

Included accessories (To order, call toll free 1-800-332-5368.)

Handset 1 pc.



PFJXE0108Z

Handset cord 1 pc.

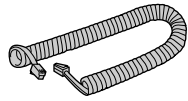

PQJA212N

Handset cradle 1 pc.

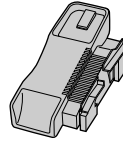

PFYAF780M

Recording paper... 1 pc.

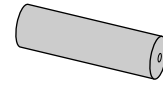

—See below for replacement of the recording paper.

Power cord 1 pc.

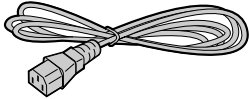

PQJA200Z

Telephone line cord..... 1 pc.



PQJA59V

Paper stacker..... 1 pc.

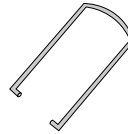

PQUS10136Z

- If any items are missing or damaged, check with the place of purchase.
- The part numbers listed above are subject to change without notice.
- Save the original carton and packaging materials for future shipping and transporting of the unit.

Accessory order information

Use the following types of recording paper for replacement. For accessory order, call toll free 1-800-332-5368.

Model No.	Description	Specifications
KX-A106	Standard Thermal Recording Paper	216 mm ~30 m (8 1/2" ~98') roll, with 25 mm (1") core
KX-A116	Standard Thermal Recording Paper	216 mm ~50 m (8 1/2" ~164') roll, with 25 mm (1") core
KX-A125	Super Thermal Recording Paper (Like plain paper)	216 mm ~30 m (8 1/2" ~98') roll, with 25 mm (1") core

Overview

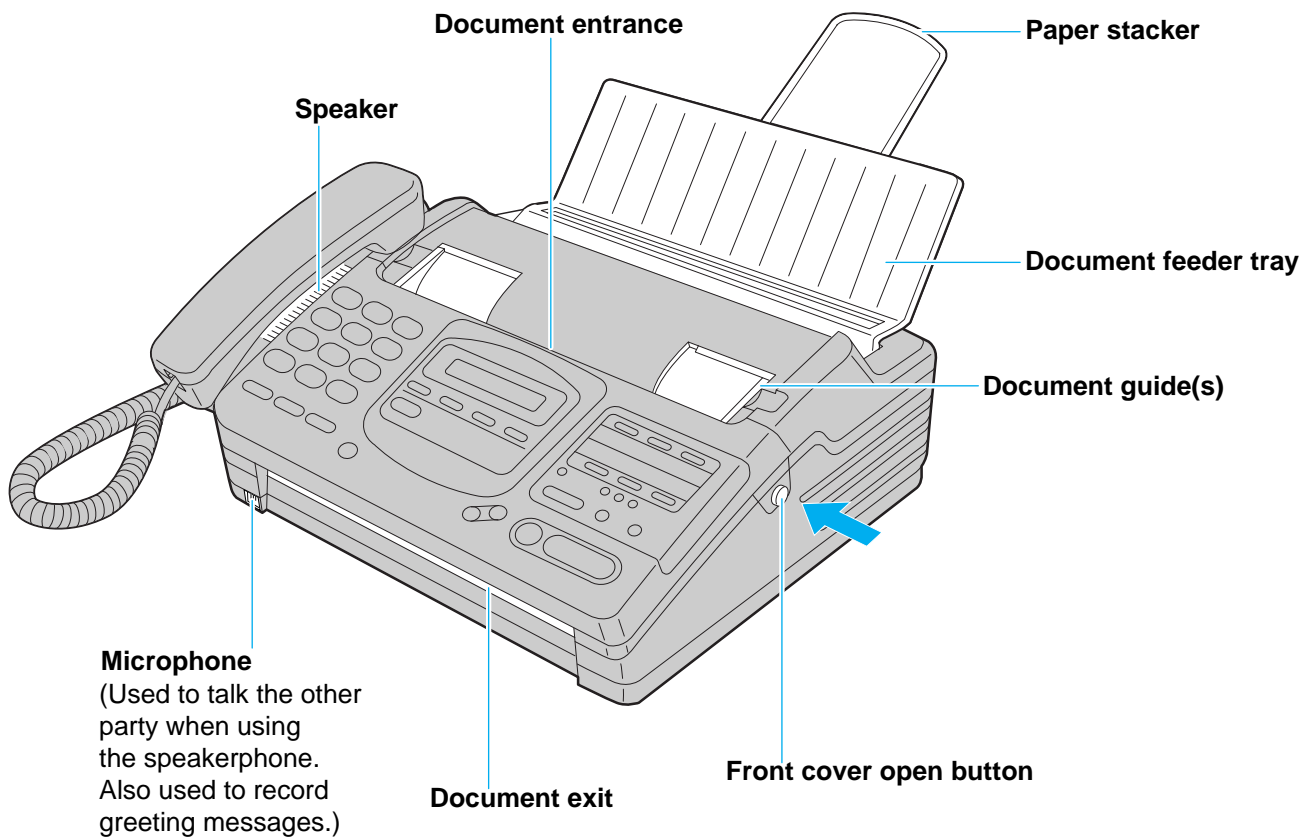

Installation

Installing the handset cradle

If you want to use this unit with a handset, install the handset and handset cradle.

- To save space or to use the unit mainly for faxes, you may remove the handset cradle.
Even if the handset and handset cradle are not installed, you can make or answer calls using the DIGITAL SP-PHONE button. When you do not use the handset and handset cradle, see pages 65 and 75.

- 1** Connect the handset cord.

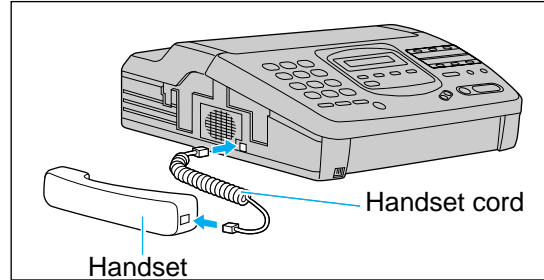

- 2** Ⓐ Open the front cover by pressing the front cover open button.
Ⓑ Open the back cover by lifting up the tabs located on both sides.

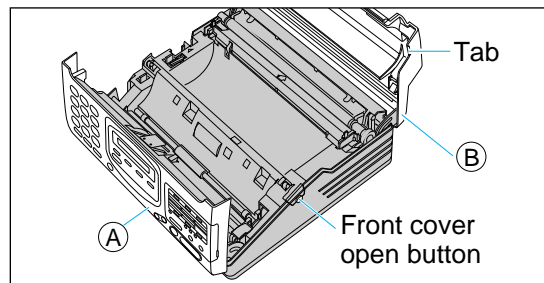

- 3** Insert the handset cradle by matching the triangles on the cradle and base unit.

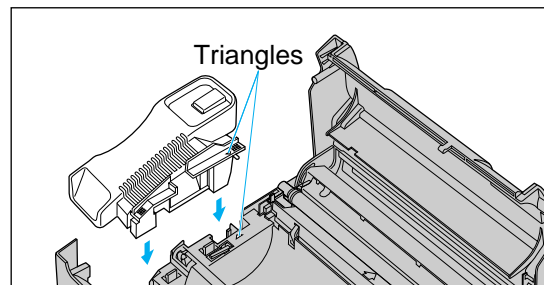

- 4** Press down on the  marked on the handset cradle until it clicks into place.
• **Make sure the two hooks lock the handset cradle into place.**

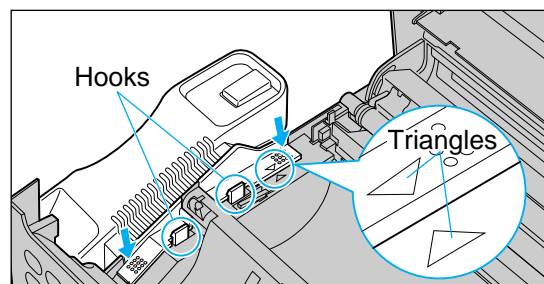

- 5** Place the handset on the handset cradle.
• Close both covers securely.

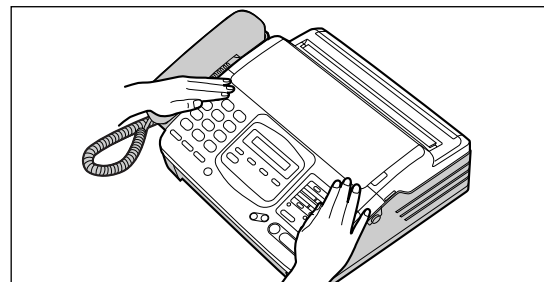

Installing the recording paper

- 1
 - Ⓐ Open the back cover by lifting up the tabs located on both sides.
 - Ⓑ Install a recording paper roll in the unit.
 - Make sure that the shiny side of the paper is facing down and there is no slack, tape, or glue residue on the paper roll.

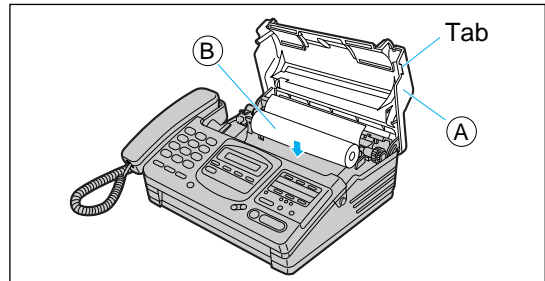
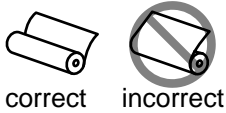

- 2 Insert the leading edge of the recording paper between the recording paper roller and the silver plate.

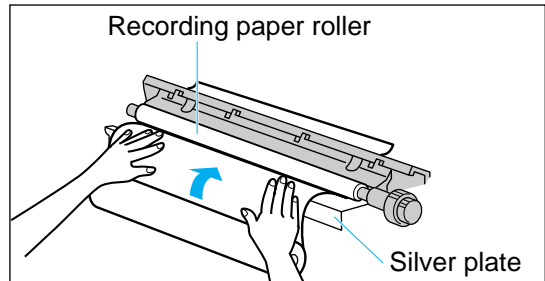

- 3 Close the back cover by gently pressing down on both corners of the cover.

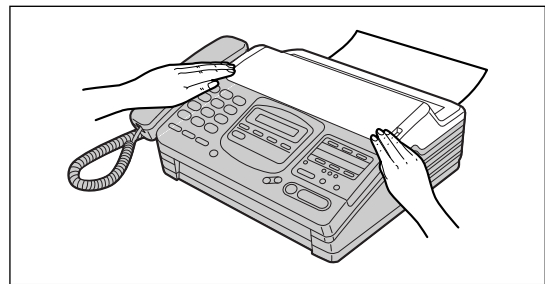

Note:

- Only use the included roll of paper or specified recording paper, or else the print quality may be affected and/or excessive thermal head wear may occur.
- The beginning of some recording paper rolls are secured with glue or tape. Cut approximately 150mm (6 inches) from the new roll of paper prior to installation.
- To order recording paper, see page 6.
- When power cord is connected (see the next page), everytime you close the back cover a message is printed. When the recording paper is set to the wrong side, a message is not printed. Install the recording paper correctly.

Installing the paper stacker

Install the paper stacker.

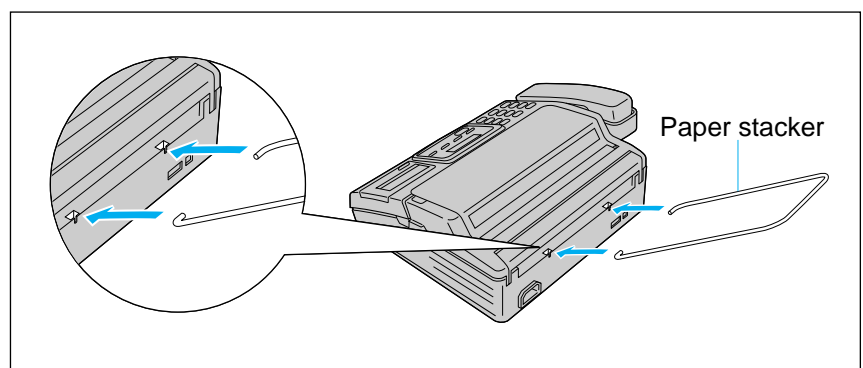

For Assistance, Call 1-800-435-7329

Connecting the telephone line and the power outlet

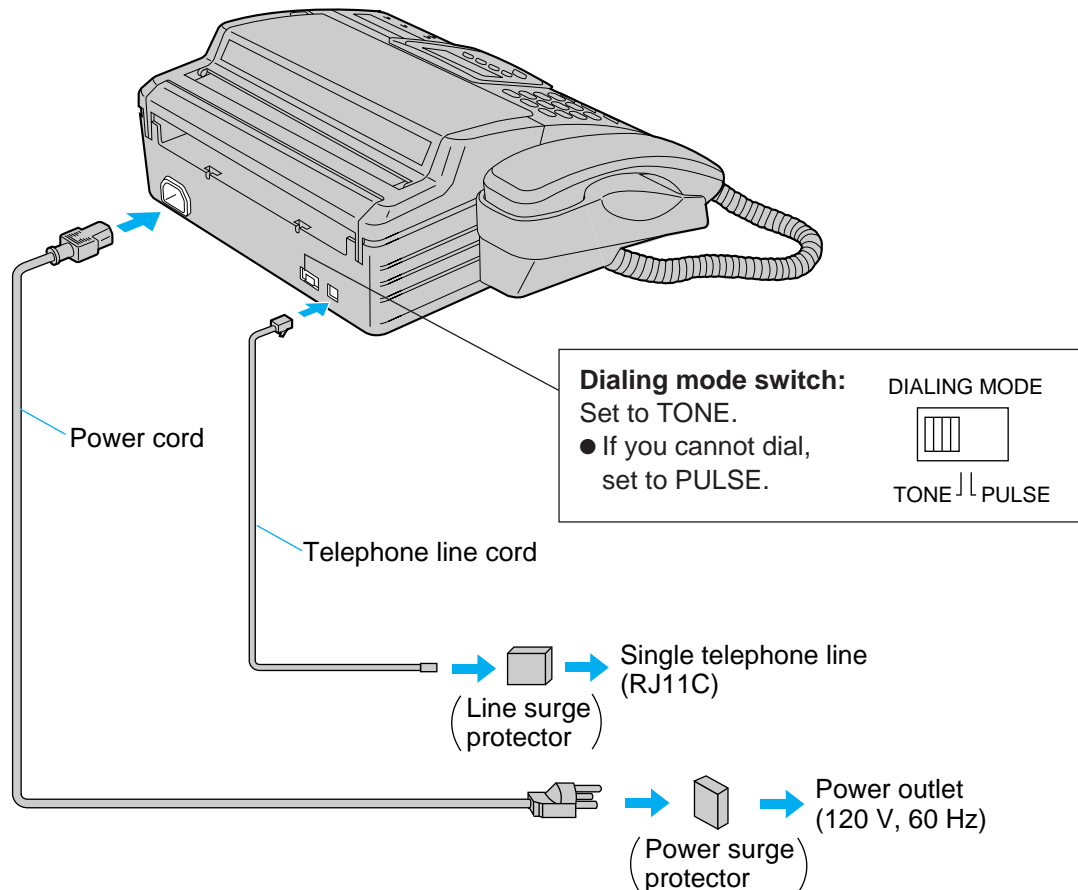

Note:

- For additional equipment protection, we recommend the use of a surge protector. The following types are available; TELESPIKE BLOK MODEL TSB (TRIPPE MFG. CO.), SPIKE BLOK MODEL SK6-0 (TRIPPE MFG. CO.), SUPER MAX (PANAMAX) or MP1 (ITW LINX).
- When you operate this product, the power outlet should be near the product and easily accessible.
- If the following message is displayed when the unit is plugged in, the handset cradle is not installed correctly.

Display: CHECK CRADLE

Install the handset cradle correctly (see page 8).

Location of controls

Control panel

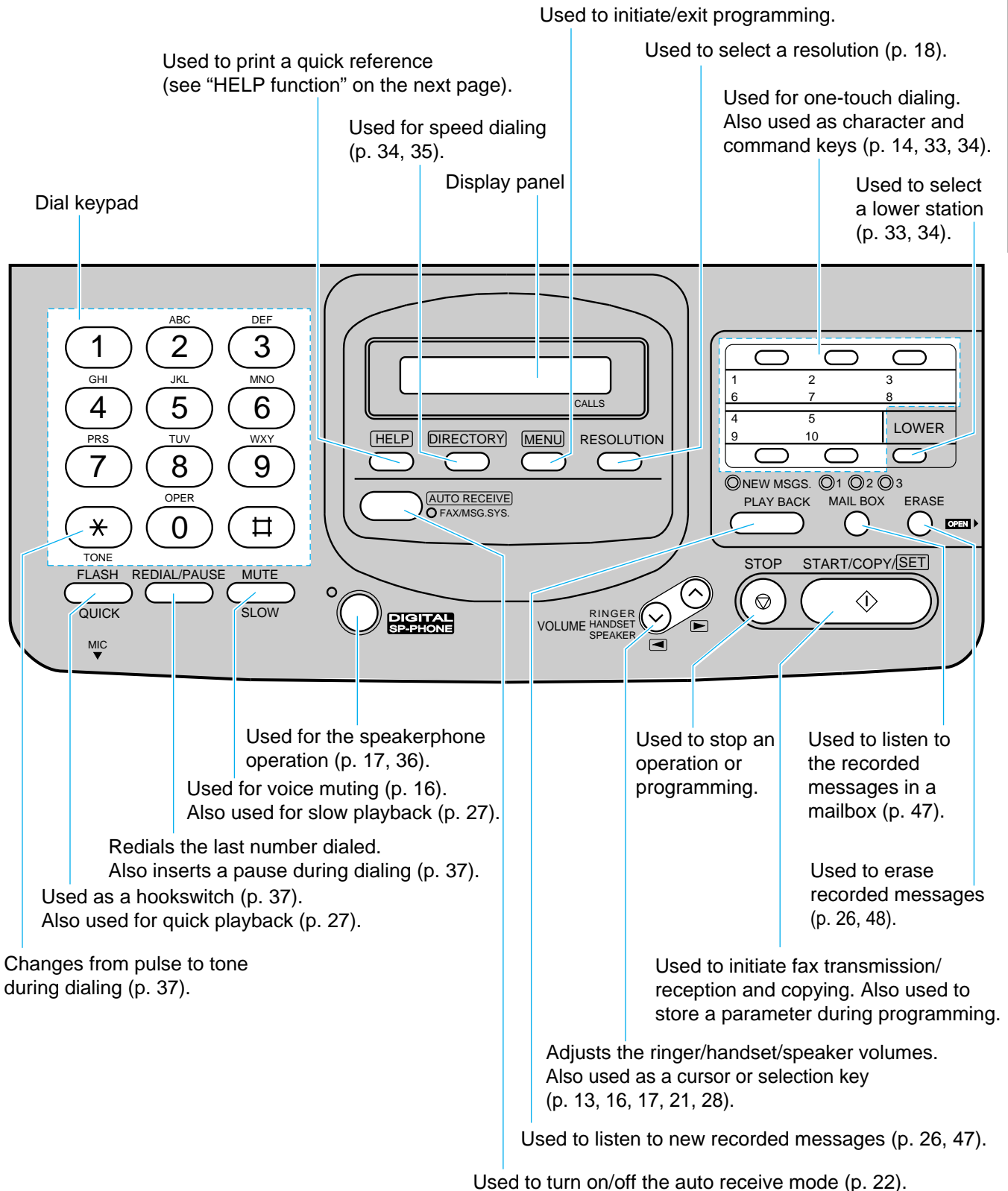

Location of controls (cont.)

Answering control buttons

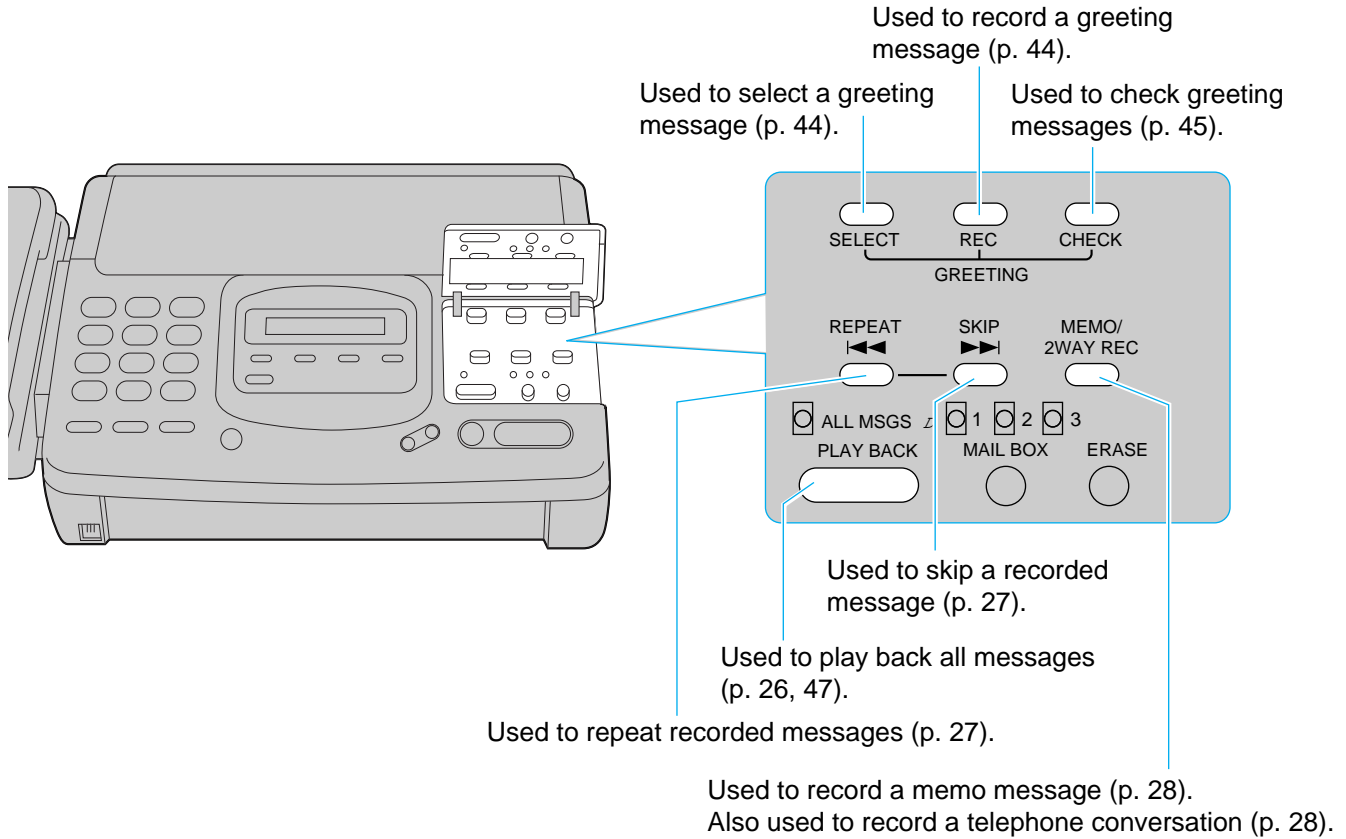

Help function

For assistance, press **HELP**. The unit will print a quick reference.

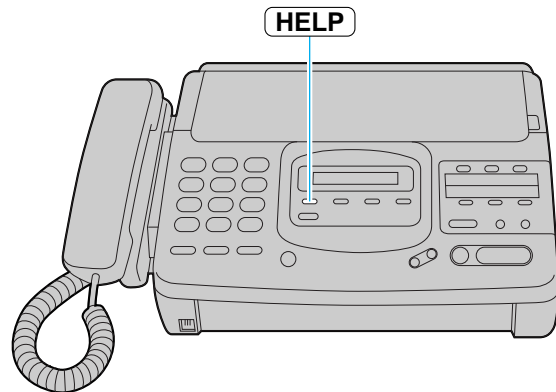

Initial preparation

Before using your unit, program the correct date and time, your logo and your facsimile telephone number.

This information will be printed on the top of each page transmitted from your unit.

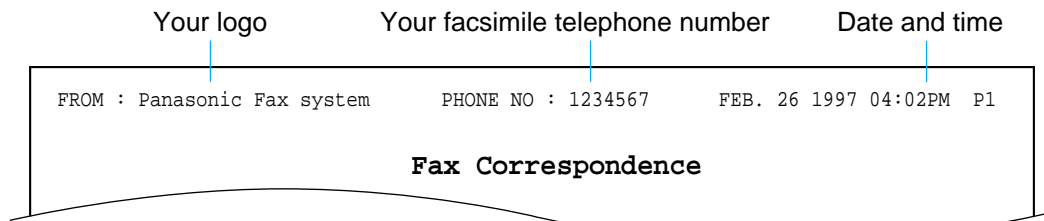

Setting the date and time

1 Press **MENU**.
Display: SYSTEM SET UP

2 Press **⏏**, then **0 1**.
SET DATE & TIME

3 Press **START/COPY/SET**.

4 Enter the correct month/day/year by selecting 2 digits for each entry.

Example: Aug. 10 1997

Press **0 8 1 0 9 7**.

M:08/D:10/Y:97

- If you make a mistake, press **⏏** or **⏏** to move the cursor to the incorrect number, then make corrections.

5 Press **START/COPY/SET**.

6 Enter the correct hour/minute by selecting each 2 digits for each entry.

Press ***** to select AM or PM.

Example: 3:00PM

Press **0 3 0 0**, then press ***** until PM is displayed.

TIME: 03:00PM

- If you make a mistake, press **⏏** or **⏏** to move the cursor to the incorrect number, then make corrections.

7 Press **START/COPY/SET**.

8 Press **MENU**.

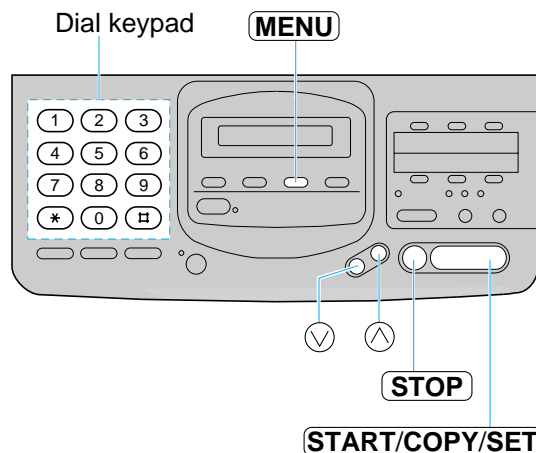

Note:

- If you press **STOP** while programming:
 - when the cursor is at the left end on the display, the display will return to the previous one.
 - when the cursor is not at the left end, the cursor will return to the previous position.
- The accuracy of the clock will be approximately ± 60 seconds a month.

Setting your logo

The logo can be a company, division or personal name in an abbreviated form.

- Press **MENU**.
Display:
- Press **⏏**, then **0 2**.
- Press **START/COPY/SET**.
- Enter your logo up to 30 characters using the dial keypad and direct call stations keys.

For example, when entering "Bill" as your logo:

- Press **2** twice.
- Press **4** six times.
- Press **5** six times.
- Press **⬆** (▶) to move the cursor and press **5** six times.

Note:

- When you use the same number key continuously to enter the next character, press **⬆** (▶) to move the cursor.

- Press **START/COPY/SET**.

- Press **MENU**.

To correct a mistake while programming

Use **⬆** (▶) and **⬆** (▶) to move the cursor to the incorrect character, then make the correction.

or
Press **STOP** to delete the character to the left of the cursor.

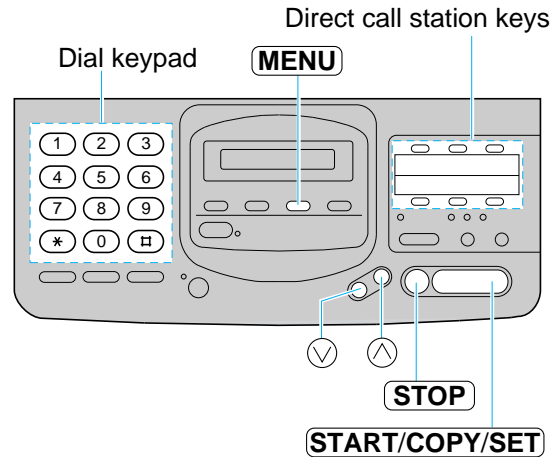

Character table

Keys	Characters
Dial keys	1 1 [] { } + - / = , . _ '
	2 A B C a b c 2
	3 D E F d e f 3
	4 G H I g h i 4
	5 J K L j k l 5
	6 M N O m n o 6
	7 P Q R S p q r s 7
	8 T U V t u v 8
	9 W X Y Z w x y z 9
	0 0 () < > ! " # \$ % & ¥
Direct call station keys	1 : ; ? * @ ^ ' α
	2 INSERT key (Used to insert one character or one space.)
	3 SECRET key (Used for automatic dialing on page 33.)
	4 SPACE key (Used to replace one character with a space.)
	5 DELETE key (Used to delete one character.)
	LOWER HYPHEN key (Used to insert a hyphen.)
⬆ (▶)	◀ key (Used to move the cursor to the left.)
⬆ (▶)	▶ key (Used to move the cursor to the right.)

Setting your facsimile telephone number

- 1 Press **MENU**.
Display:
- 2 Press **□**, then **0 3**.
- 3 Press **START/COPY/SET**.
- 4 Enter your facsimile telephone number up to 20 digits.
 - The **□** button replaces a character with a space and the ***** button inserts a "+".
 - If you make a mistake, press **STOP** to delete the wrong number to the left of the cursor.
Or
press **⏪** or **⏩** to move the cursor to the incorrect number, then make corrections.
- 5 Press **START/COPY/SET**.
- 6 Press **MENU**.

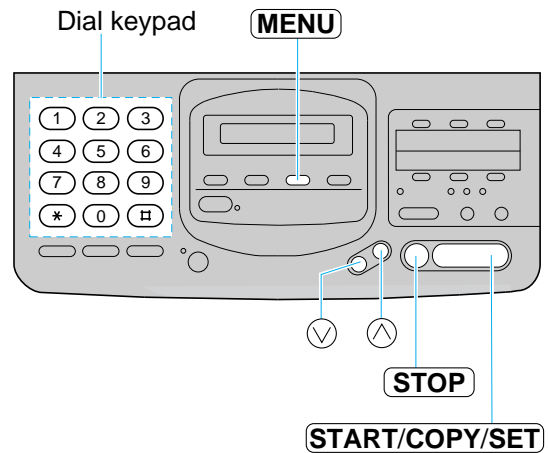

Basic operations

Making voice calls

- 1 Press **DIGITAL SP-PHONE** or lift the handset.
- 2 Dial the phone number.
 - If you misdial, hang up and dial again.
- 3 When the other party answers, speak into the microphone or handset.
- 4 When finished, press **DIGITAL SP-PHONE** or hang up the handset.

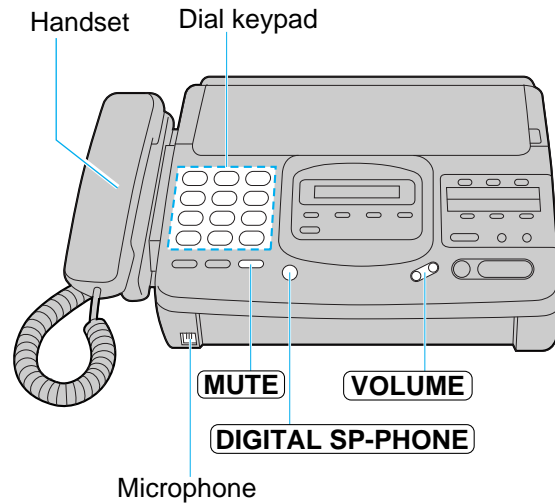

Voice muting

Using this feature, the other party cannot hear you but you can hear them.

1. Press **MUTE** during a telephone conversation.

Display:

<MUTE>

2. To resume the conversation, press **MUTE**.

Hints for speakerphone operation

- Use the speakerphone in a quiet room.
- If you have difficulty hearing the other party, adjust the volume using **VOLUME**.
- If you and the other party speak at the same time, parts of your conversation will be cut off.
- To switch to the handset, lift the handset. To switch back to the speakerphone, press **DIGITAL SP-PHONE**.

Handset volume

Press **VOLUME** (/ -) while using the handset.

- 3 levels (high/middle/low) are available.

Speaker volume

Press **VOLUME** (/ -) while using the speakerphone.

- 8 levels (high to low) are available.

Answering voice calls

- 1 When the unit rings, press **DIGITAL SP-PHONE** or lift the handset.
- 2 When finished, press **DIGITAL SP-PHONE** or hang up the handset.

Caller ID capability

This unit is compatible with a Caller ID service offered by your local telephone company. To use this feature, you must subscribe to a Caller ID service.

Caller ID allows you to view the name or telephone number of the caller before you answer the phone. The calling party information (name has priority) will be displayed after the first ring.

By using Caller ID, you have the option of whether or not to answer the call depending on the caller.

The unit also keeps the caller's information and prints a list automatically after every 20 calls.

- To set this feature, see page 69.
- To print out the caller list manually, see page 66.

Note:

- When a second call is received by a call waiting service, the caller ID information will not be displayed or stored in the caller list.

Important:

- When you subscribe to a Caller ID service, set the ring count settings to 2 or more rings (ANS/FAX mode ring count - p. 57, FAX mode ring count - p. 58, TEL/FAX mode ring count - p. 58).

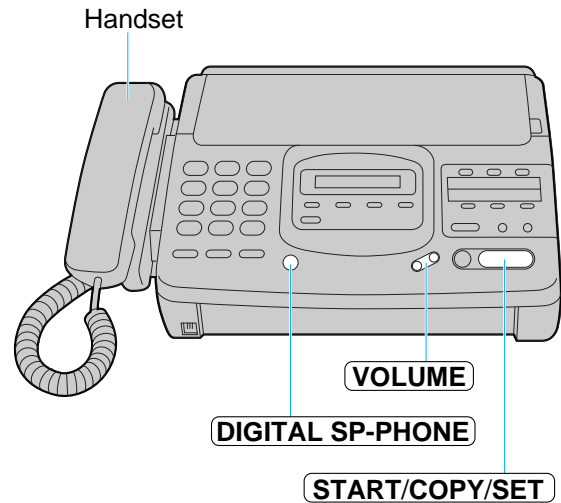

Ringer volume

Press **VOLUME** (/ ·) while the unit is idle.

- 4 levels (high/middle/low/off) are available.

To turn the ringer off:

1. Press **VOLUME** () repeatedly.
 - The following messages will be shown alternately.

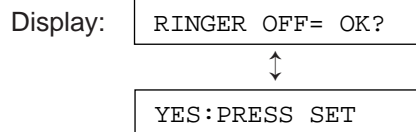

2. Press **START/COPY/SET**.

While the ringer volume is set to off:

The display will show the following message and the unit will not ring when receiving a call.

RINGER OFF

When a call is received, the unit will not ring but show the following message.

INCOMING CALL

For Assistance, Call 1-800-435-7329

Making a copy

Any transmittable document can be copied.

- 1 Open the document feeder tray.
- 2 Insert the documents (up to 15 sheets) **FACE DOWN** until a beep tone is heard.
- 3 Adjust the document guides to the width of the document.
- 4 Press **RESOLUTION** repeatedly to the desired setting, if needed (see below).
- 5 Press **START/COPY/SET** to start copying.
 - The unit will start printing.

Note:

- When copying, the unit will automatically select FINE resolution.
- You can make or receive a voice call while making a copy.

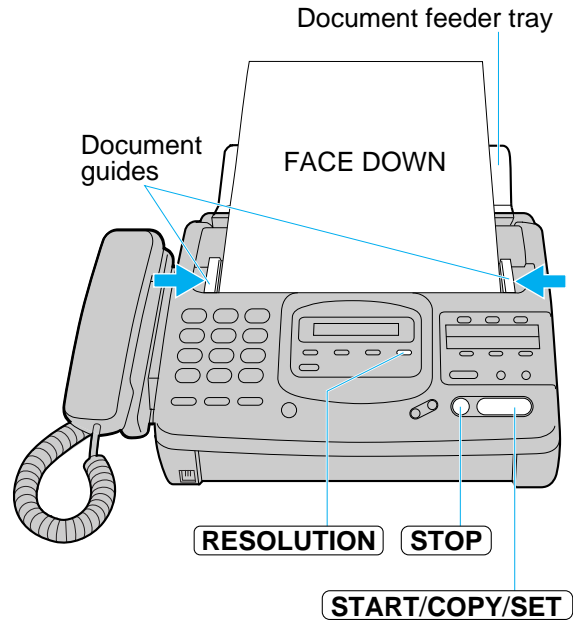

To stop copying

Press **STOP**.

Selecting the resolution

Press **RESOLUTION** to the desired setting.

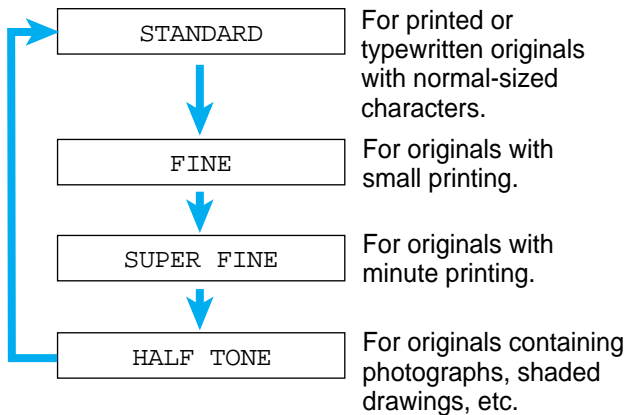

Note:

- Using the fine, super fine or half tone setting will increase the transmission time.
- If the resolution setting is changed during feeding, it will be effective from the next sheet.
- The super fine resolution only works with other compatible machines.

To feed 16 or more sheets at a time

Insert the first 15 sheets of the document. Add the extra sheets (up to 15) before the last sheet is fed into the unit.

Transmitting documents

- 1 Open the document feeder tray.
- 2 Insert the documents (up to 15 sheets) FACE DOWN until a beep tone is heard.
- 3 Adjust the document guides to the width of the document.
- 4 Press **RESOLUTION** repeatedly to the desired setting, if needed (see page 18).
- 5 Press **DIGITAL SP-PHONE** or lift the handset.
- 6 Dial the correct phone number.
 - If you misdial, hang up and dial again.
- 7 **When a fax tone is heard**, press **START/COPY/SET**.
- 8 Hang up the handset if using it.

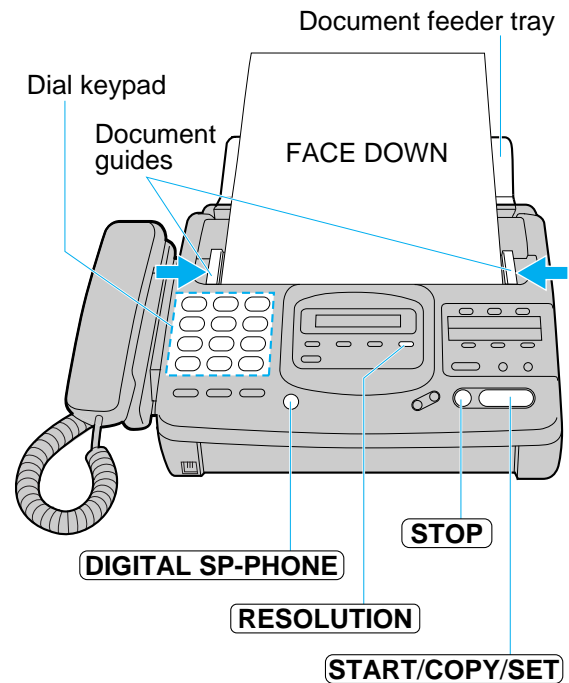

Note:

- If the other party answers your call, ask them to start receiving a fax, then press your **START/COPY/SET**.

To stop transmission

Press **STOP**.

- To eject the document, press **STOP** again.

Fax voice guidance about transmission

After transmission, one of the following messages will tell you the result.

- *Transmission is complete.*
- *Transmission has failed.*

You can set this feature to OFF and the guidance will not be heard. Or you can set this feature to ERROR and the guidance will tell you the result only when fax transmission fails (see page 63).

Transmitting documents (cont.)

Documents the unit can feed

Minimum size

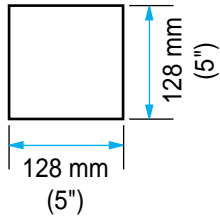

Maximum size

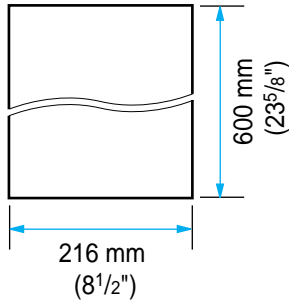

Effective scanning area

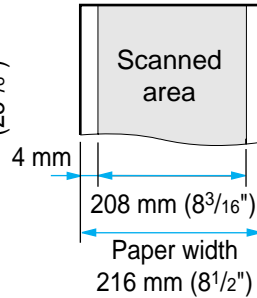

Document weight

Single sheet:
45 to 90 g/m² (12 to 24 lb.)
Multiple sheets:
60 to 75 g/m² (16 to 20 lb.)

Note:

- Remove clips, staples or other similar fastening objects.
- Check that ink, paste or correction fluid has dried.
- Do not send the following types of documents. Use copies for fax transmission.
 - Chemically treated paper such as carbon or carbonless duplicating paper
 - Electrostatically charged paper
 - Heavily curled, creased or torn paper
 - Paper with a coated surface
 - Paper with a faint image
 - Paper with printing on the opposite side that can be seen through the front (e.g. newspaper)

Need help? — Follow the voice guide

1 Press **MENU** until the following is displayed.

Display: XMF VOICE GUIDE

2 Press **HELP**.

Voice guide:

To transmit, insert the document face down until you hear the beep.

3 Insert the documents **FACE DOWN** until a beep tone is heard.

Voice guide:

Press the speaker phone button, then dial the phone number. When the fax tone is heard, press the start button.

4 Press **DIGITAL SP-PHONE**.

5 Dial the phone number.

6 When a fax tone is heard, press **START/COPY/SET**.

Voice guide:

Start transmission.

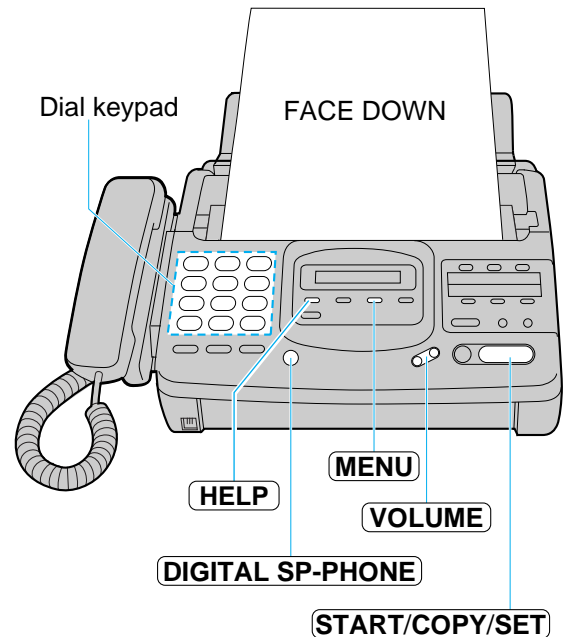

Note:

- You can lift the handset instead of pressing **DIGITAL SP-PHONE** in step 4.

Fax voice guidance volume

Press **VOLUME** (/ ·) while listening to the voice guidance.

- 9 levels (high to off) are available.

Receiving documents (receive mode, etc.)

Setting the receive mode

This unit has two receive modes:

The **AUTO RECEIVE** mode allows your unit to receive all calls automatically without your assistance. Use this mode when you wish to use the unit solely as a facsimile machine or when you are going out.

The **MANUAL RECEIVE** mode lets you answer calls by lifting the handset. Use this mode when you are in and wish to answer voice and fax calls.

These modes can be selected by pressing the **AUTO RECEIVE** button.

AUTO RECEIVE and MANUAL RECEIVE have two different receive settings.

MANUAL RECEIVE MODE

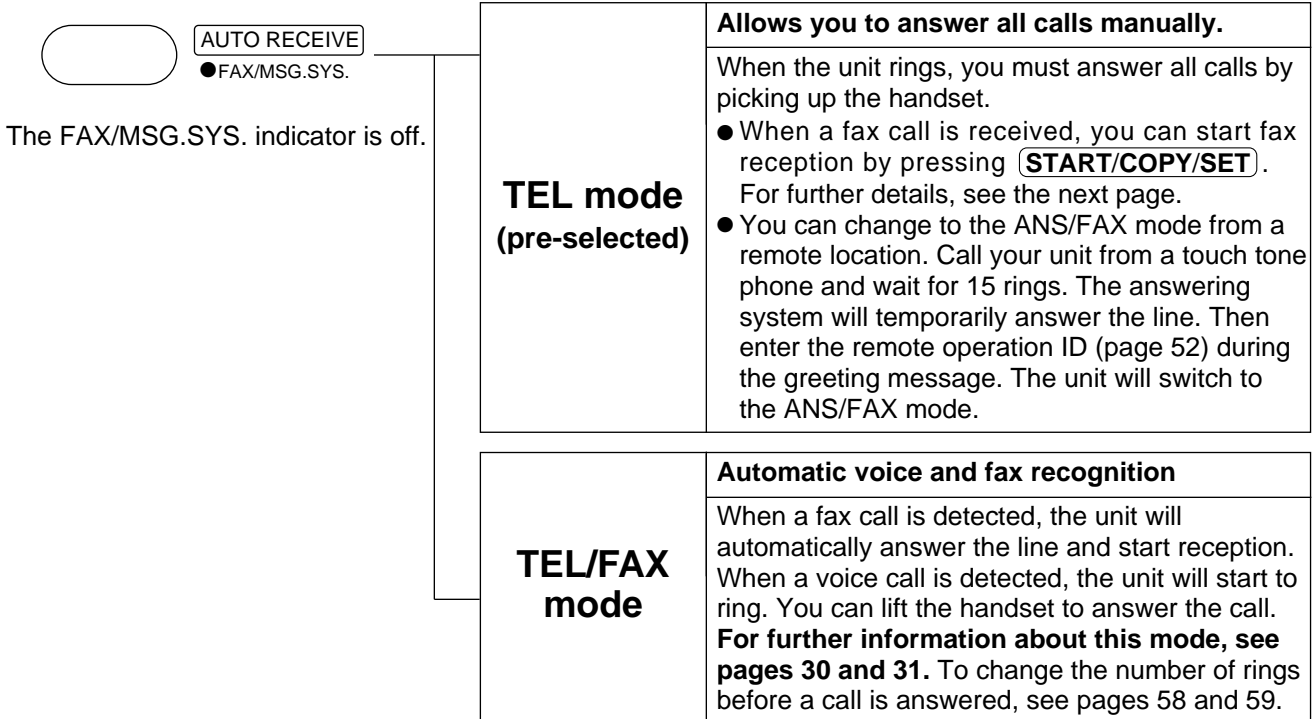

AUTO RECEIVE MODE

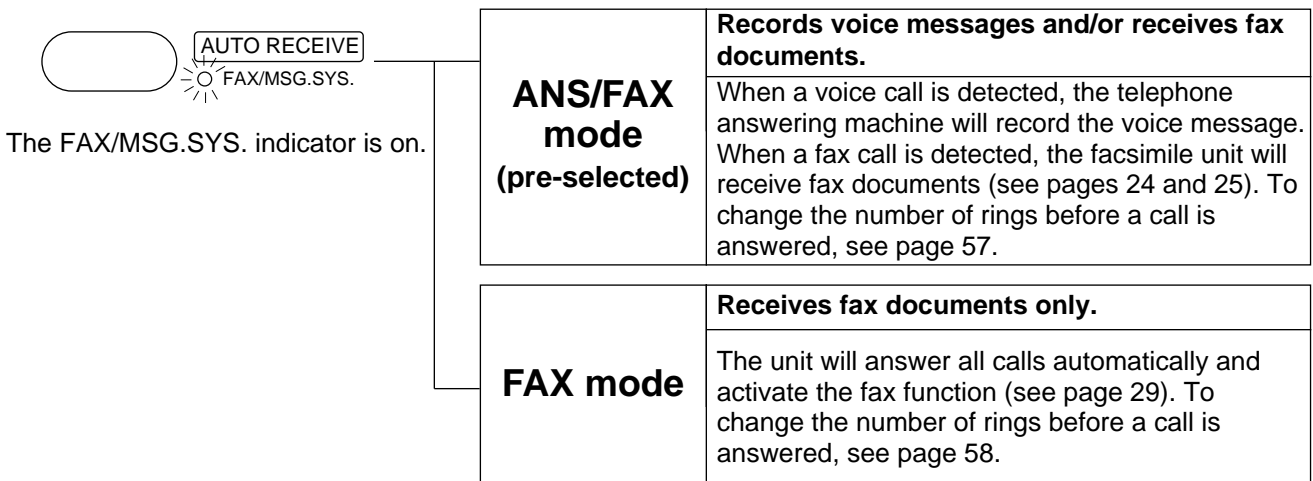

Note:

- Regardless of the mode you select, you can always place calls and send faxes.

Allowing you to answer all calls manually (TEL mode) —

- 1 When the unit rings, press **DIGITAL SP-PHONE** or lift the handset to answer the call.
- 2 When:
 - document reception is required,
 - a slow beep is heard, or
 - no sound is heard,
 press **START/COPY/SET**.
- 3 Hang up the handset if using it.
 - The recording paper will print out face side down.

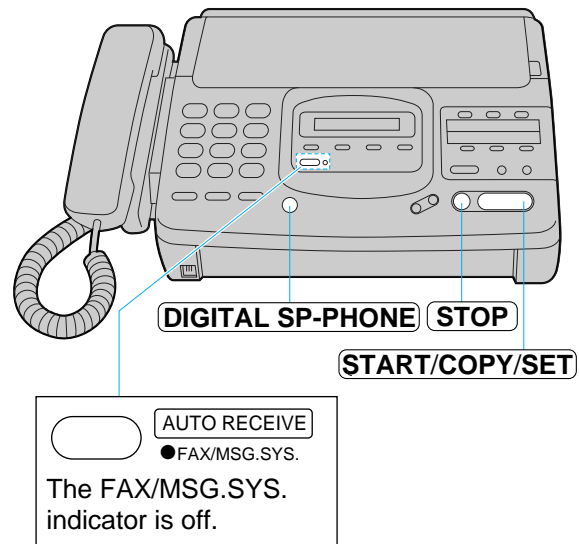

Friendly reception

When you answer a call and hear a slow beep, the unit will automatically start fax reception even if you do not press **START/COPY/SET**.

- The friendly reception feature can be set to OFF (see page 62).

When friendly reception is activated, one of the following messages will be heard.

- Please hang up the handset for reception.*
- Start reception.*

- If the voice guidance feature is set to OFF, these messages will not be heard (see page 63).

Fax voice guidance about reception

After reception, one of the following messages will tell you the result.

- Reception is complete.*
- Reception has failed.*
- Reception has been interrupted.*

- You can set this feature to OFF. Or you can set this feature to ERROR and the guidance will tell you the result only when fax reception fails (see page 63).
- When the unit receives fax documents automatically, the voice guidance will not be played.

Memory reception

When a printing problem is detected, the unit will temporarily store the received document into memory. While documents are in memory, the unit will display an error message and the following message alternately;

Display: **FAX IN MEMORY**

- Follow the instructions on page 70 to clear the problem and print the stored document.

Caution:

- If both fax documents and voice messages are received in memory, the corresponding capacities (see page 80) will be shortened.

To stop reception

Press **STOP**.

Receiving documents (receive mode, etc.) (cont.)

Receiving fax documents and/or recording incoming voice messages automatically (ANS/FAX mode)

When you turn on the AUTO RECEIVE mode (pre-selected setting is ANS/FAX), the unit will work as a facsimile machine and/or answering device.

If a fax call is detected, the unit will automatically switch to the fax for reception.

If a voice call is detected, the answering system will begin recording, then the caller can leave a voice message.

- You can use a pre-recorded greeting message (see the next page) or create your own greeting message (see page 44).

Setting up voice message and document reception

The total recording time (including the greeting messages) is about 18 minutes when no fax documents are in memory. If messages are recorded in noisy rooms, the time may be shortened up to 7 minutes.

To record incoming voice messages and receive fax documents, follow the steps below:

- 1 Make sure that the AUTO RECEIVE mode is set to ANS/FAX (see page 29).
- 2 Turn on the AUTO RECEIVE mode by pressing **AUTO RECEIVE** until the FAX/MSG.SYS. indicator light goes on.
 - The display shows the following message.

Display: ANS / FAX MODE

The remaining time for recording incoming messages will be displayed.

Example: TIME LEFT=10m13s

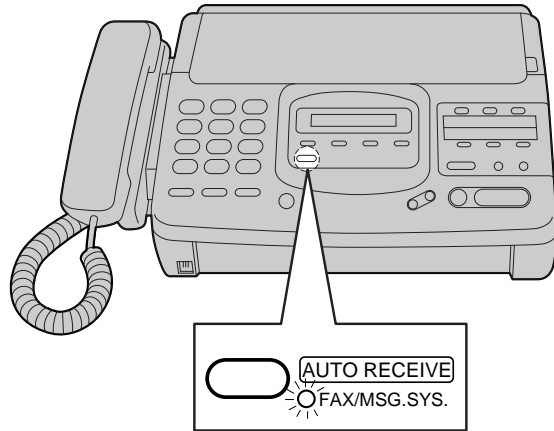

The FAX/MSG.SYS. indicator is on.

Note:

- Each incoming message recording time can be set to either 1 minute or unlimited. To change the setting, see page 59.
- When the remaining time is low, erase unnecessary messages from memory (see page 26).

Pre-recorded greeting messages

The unit has pre-recorded greeting messages in common memory. According to the mode, one of the following messages will be played to the caller.

- When your own greeting message (page 44) is not recorded, the following greeting message will be played.

*Hello! We are unable to answer right now.
To send a fax, please start transmission.
To leave a voice message, please speak after the beep.
Thank you.*

- When the unit detects a problem, one of the following pre-recorded greeting messages will be played.

Memory full

*Hello! We are unable to answer right now.
To send a fax, please start transmission.
To leave a voice message, please try again later.
Thank you.*

Memory full and out of paper
OR
Memory full and unit overheated

*Hello! We are unable to answer right now.
Please try again later.
Thank you.*

Note:

- If you erase your own greeting messages, the pre-recorded greeting messages will play automatically.

Operating the answering device

Listening to messages in common memory

When the unit receives voice messages;

- the NEW MSGS. indicator will flash,
- the call counter will show the total number of recorded messages, and
- a slow beep will sound if message alert (page 61) is set to ON.

■ Listening to new recorded messages

Press **NEW MSGS. PLAY BACK**.

■ Listening to all of the recorded messages

Open the station key panel, then press

ALL MSGS. PLAY BACK.

Note:

- During playback, the display shows the recorded order of the messages.
- Adjust the speaker volume using **VOLUME**.
- The number of calls in the call counter will not reset until you erase your messages.

Voice time/day stamp:

During playback, a synthesized voice will announce the time and day when each message was recorded.

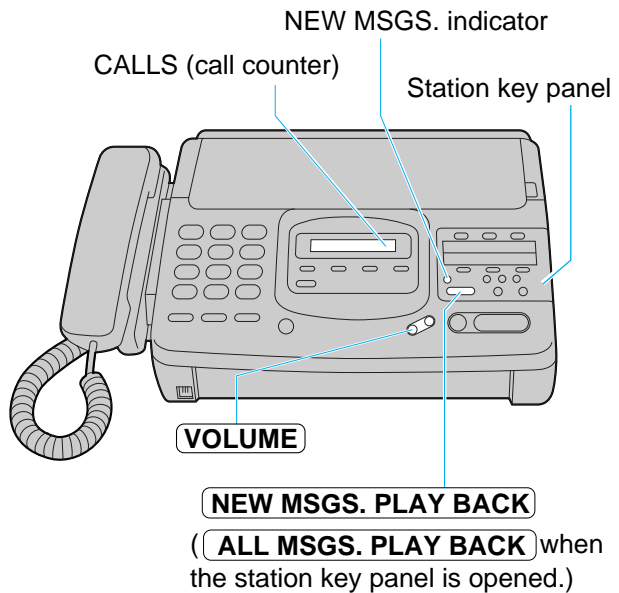

Erasing recorded messages

Erase unnecessary messages to prevent memory from becoming full.

■ Erasing specific messages from memory

Press **ERASE** when the message you want to erase is playing.

■ Erasing all messages in common memory

1. Press **ERASE** after listening to all of the messages.

Display: **CLEAR MESSAGES?**
 ↓
YES: PRESS SET

- To cancel erasing, press **STOP**.

2. Press **START/COPY/SET**.

ERASE COMPLETED

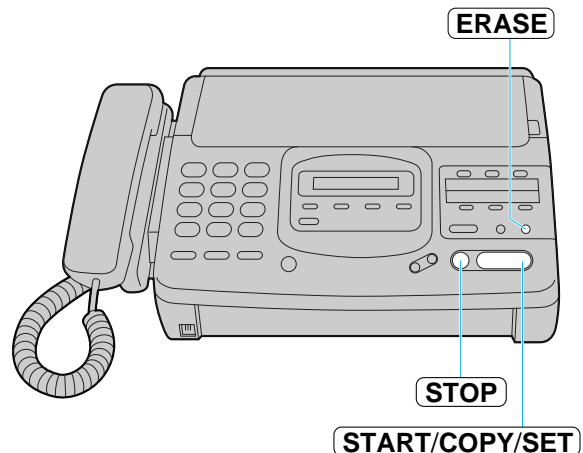

Functions during playback

■ Repeating a message

Press **REPEAT** while the message you want to listen to is playing.

- If you press **REPEAT** within 5 seconds of the beginning of the message, the previous message will be played.
- To play back a specific message, press **REPEAT** repeatedly until the message you want to play back is heard.
- When you want to repeat the new messages, press **NEW MSGS. PLAY BACK** first, open the station key panel and press **REPEAT**.

■ Skipping a message

Press **SKIP** to play back the next message.

- When you want to skip the new messages, press **NEW MSGS. PLAY BACK** first, open the station key panel and press **SKIP**.

■ Changing the playback speed

Press **QUICK** to play back messages at one and a half times the original speed.

Press **SLOW** to play back messages at half the original speed.

To return to the original speed:

Press **QUICK** or **SLOW** again during quick or slow playback.

■ Stopping the operation

Press **STOP** to stop playback.

- To resume the new recorded messages, press **NEW MSGS. PLAY BACK** within 1 minute after pressing **STOP**.
- To resume all of the recorded messages, press **ALL MSGS. PLAY BACK**.

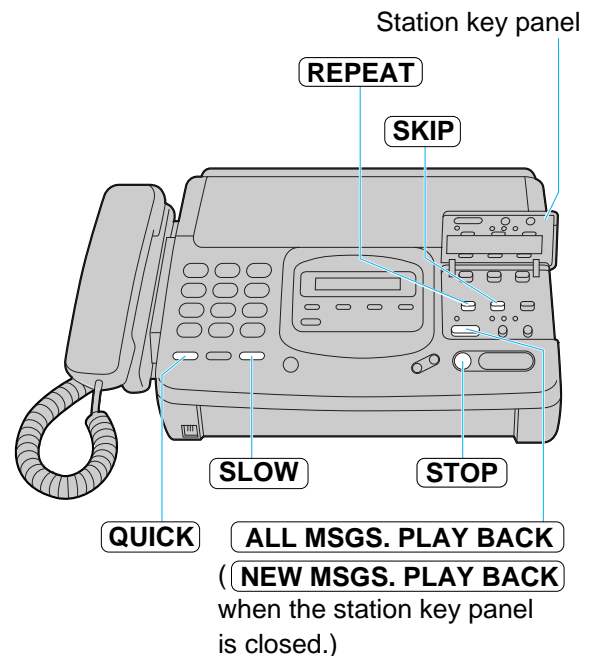

Operating the answering device (cont.)

Recording a memo message

If you are going out and want to leave a private message for someone, you can record a voice memo in the unit. This can be played back later, either directly or remotely, like other messages.

- 1 Open the station key panel.
- 2 Press **MEMO/2WAY REC**.
 - A long beep will sound.
- 3 Speak clearly into the microphone.
- 4 When finished, press **STOP**.

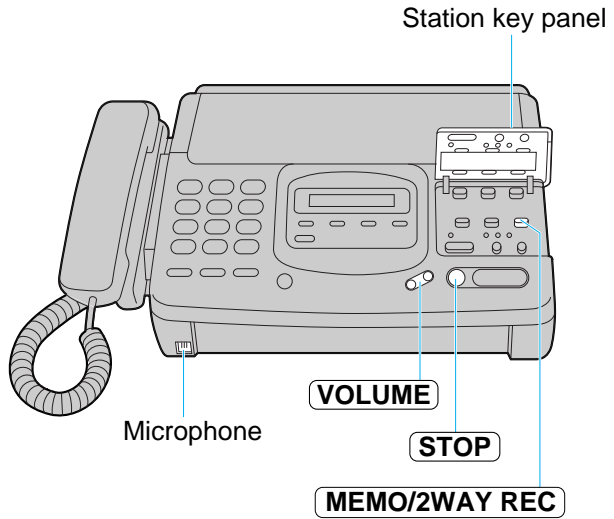

Recording a telephone conversation

While you are talking with the handset, the telephone conversation can be recorded.

- 1 During the telephone conversation, open the station key panel.
- 2 Press **MEMO/2WAY REC**.

Display: 2WAY RECORDING
- 3 To stop recording, press **STOP** or hang up.

Note:

- There may be legal restrictions in your state on recording two way telephone conversations. The other party should be informed that the conversation is being recorded.

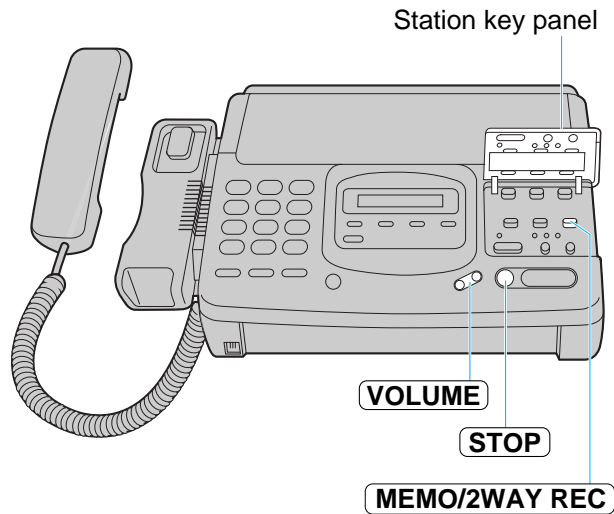

Answering device volume

Press **VOLUME** (/ ·) while listening to recorded messages.

- 9 levels (high to off) are available.

Special receiving modes

FAX mode (receiving fax documents only)

When you turn on the AUTO RECEIVE mode that is set to FAX, the unit works as a dedicated facsimile machine.

The unit will automatically answer all calls and generate fax tones to the callers.

Changing the AUTO RECEIVE mode setting

Change the AUTO RECEIVE setting from the ANS/FAX mode to the FAX mode.

- 1 Press **MENU**.
Display:
- 2 Press **□**, then **0 5**.
- 3 Press **START/COPY/SET**.
- 4 Press **∇** or **▲** to select FAX.
 - To return to the ANS/FAX mode, select ANS/FAX.
- 5 Press **START/COPY/SET**.
- 6 Press **MENU**.

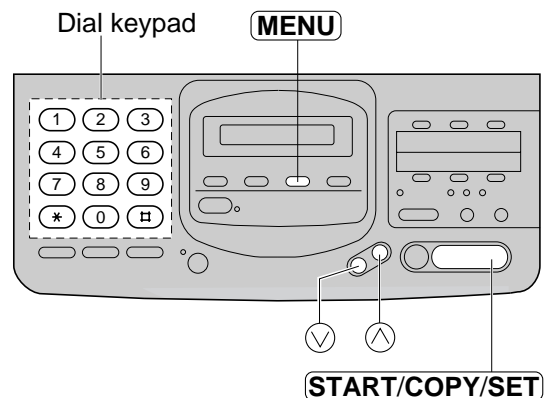

Advanced
Operations

Setting the FAX mode

Press **AUTO RECEIVE** until the FAX/MSG.SYS. indicator light goes on.

- The display shows the following message.

Display:

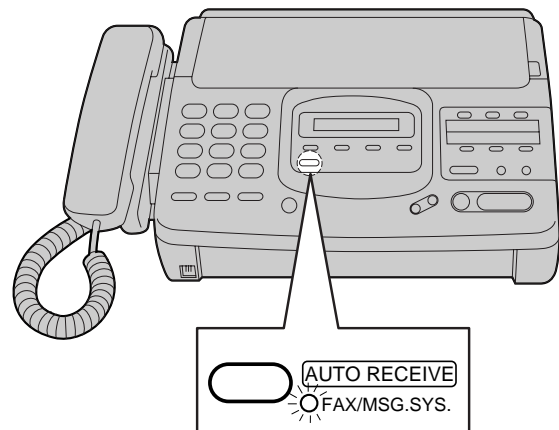

The FAX/MSG.SYS. indicator is on.

TEL/FAX mode

(automatic voice and fax recognition)

Use this mode when you wish to receive voice calls with rings and do not want to hear the unit ring when faxes are received.

When a call is received, the unit will work as follows.

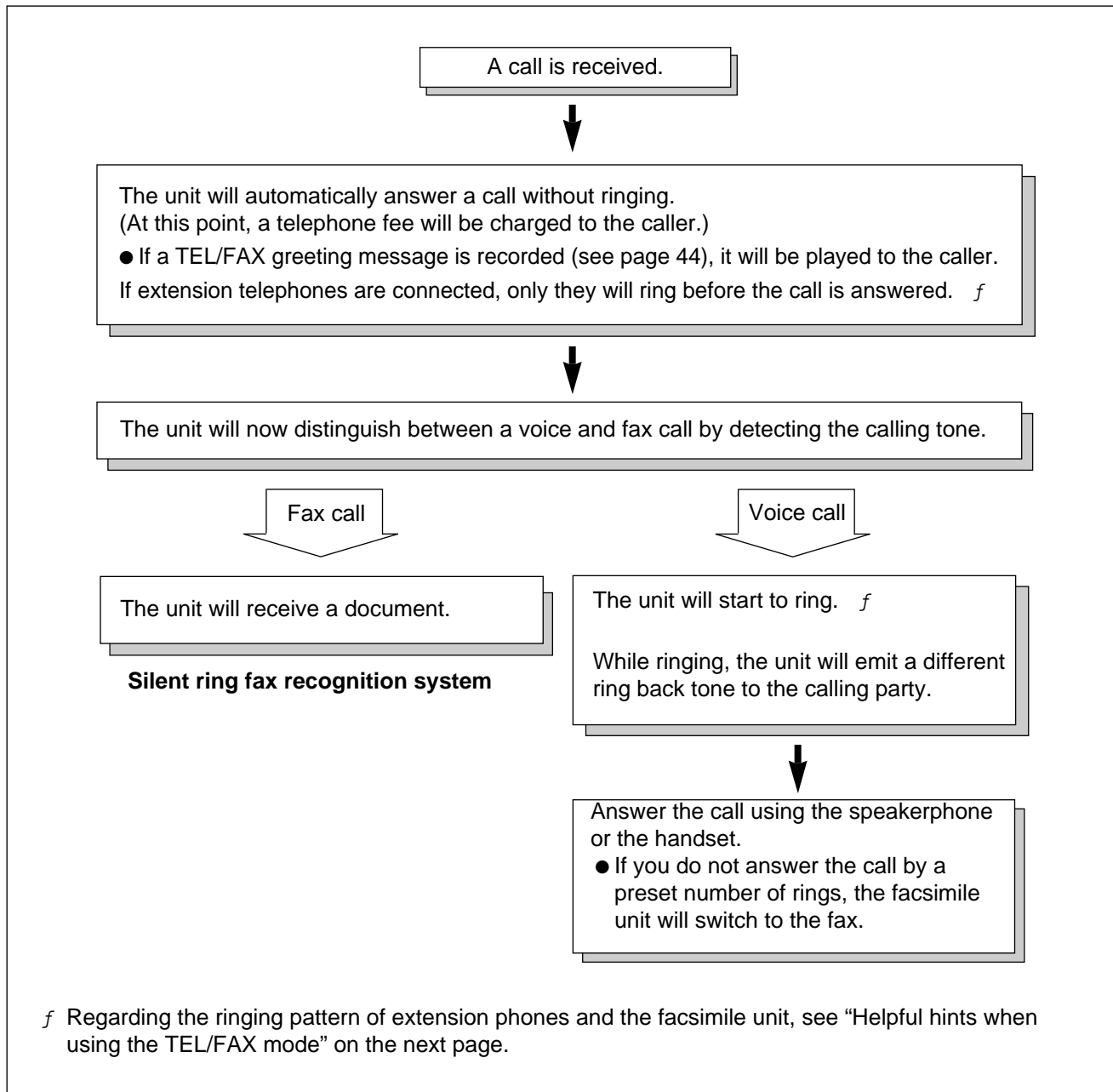

Note:

- Some fax messages that are transmitted manually may not send a calling tone. These calls must be received manually.

Helpful hints when using the TEL/FAX mode

If an extension telephone is connected, the facsimile unit and the extension telephone will ring as follows.

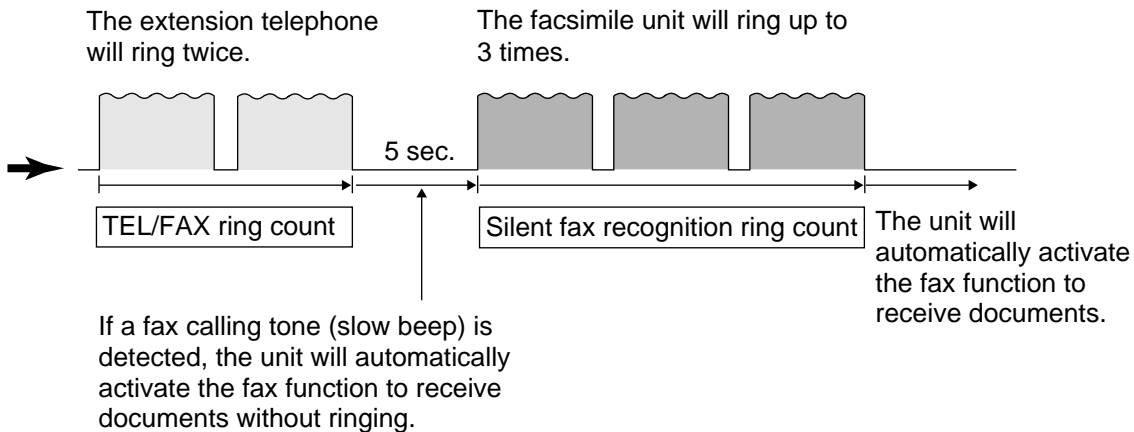

Note:

- You can change the number of rings for the TEL/FAX ring count (see "Setting the TEL/FAX mode ring count" on page 58) and silent fax recognition ring count (see "Setting the silent fax recognition ring count" on page 59).

Setting the TEL/FAX mode

Change the MANUAL RECEIVE setting from the TEL mode to TEL/FAX mode.

- 1** Press **MENU**.
Display: SYSTEM SET UP
- 2** Press **#**, then **0 8**.
MANUAL RECEIVE
- 3** Press **START/COPY/SET**.
MODE=TEL [v ^]
- 4** Press **v** or **^** to select TEL/FAX.
MODE=TEL/FAX [v ^]

- To return to the TEL mode, select TEL.

- 5** Press **START/COPY/SET**.
- 6** Press **MENU**.

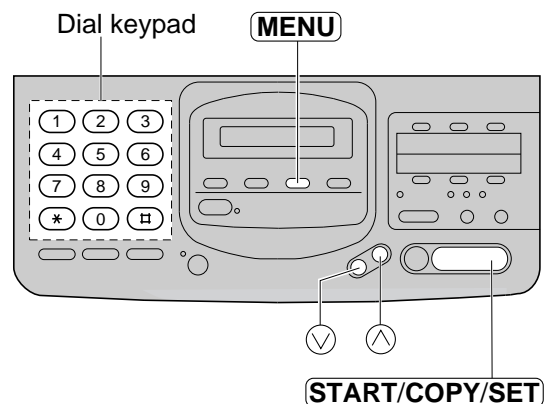

TEL/FAX mode (cont.)

Using the TEL/FAX mode

- 1** Record a TEL/FAX mode greeting message (see page 44).
 - The TEL/FAX mode greeting message will be played to the caller when the unit automatically answers an incoming call.
- 2** Set the MANUAL RECEIVE mode to TEL/FAX (see page 31).
- 3** Make sure that the AUTO RECEIVE mode is turned off.
 - If the FAX/MSG. SYS. indicator light is on, press **AUTO RECEIVE** to turn off the AUTO RECEIVE mode.
 - The display shows the following message.

Display: TEL/FAX MODE

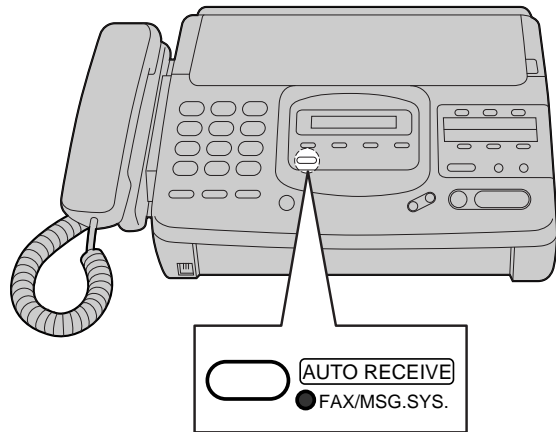

The FAX/MSG.SYS. indicator is off.

Automatic dialing

Storing phone numbers for automatic dialing

The unit's memory allows you to use both one-touch dialing and speed dialing for rapid access to your most frequently dialed numbers.

One-touch dialing: The unit is equipped with 5 direct call station keys, each of which is divided into an upper station and a lower station.

Speed dialing: The unit is equipped with 50 additional dialing stations. These stations are assigned to 2-digit numbers (00–49).

1 Press **MENU** until the following message is displayed.

Display:

2a One-touch dialing:

For upper stations (1–5)

Press one of the direct call station keys.

For lower stations (6–10)

Press **LOWER**, then press one of the direct call station keys.

2b Speed dialing:

Press **□**, then press the desired 2-digit number (00–49).

3 Enter the phone number up to 30 digits in length.

- To enter a hyphen in a phone number, press **LOWER**.

4 Press **START/COPY/SET**.

5 Enter the station name, up to 10 characters, by following the instructions on page 14.

6 Press **START/COPY/SET**.

- To program other stations, repeat steps 2 to 6.

7 Press **STOP**.

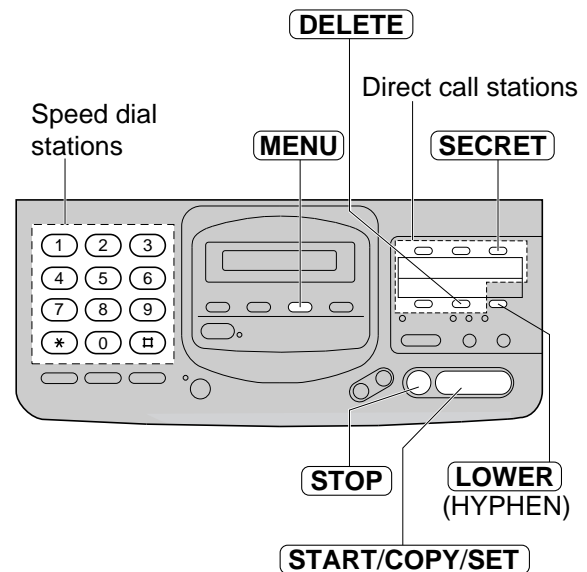

Helpful hint:

- To confirm stored phone numbers and station names, print a telephone number list (see page 66).

To keep the phone number secret

Press **SECRET** (direct call station 3) after entering the phone number.

- The phone number will not appear on the display and on the telephone number list.
- **SECRET** is not counted as a digit.

To erase a stored number and station name

Press **STOP** in step 3 to erase the phone number. Press **DELETE** (direct call station 5) repeatedly in step 5 until all of the characters are erased. Then press **START/COPY/SET**.

Making voice calls using automatic dialing

1 Press **DIGITAL SP-PHONE** or lift the handset.

2a Using one-touch dialing:

For upper stations (1–5)
Press the desired direct call station key.

For lower stations (6–10)
Press **LOWER**, then press the desired direct call station key.

2b Using speed dialing:

Press **DIRECTORY**, then press **☐** and the desired 2-digit number (00–49).

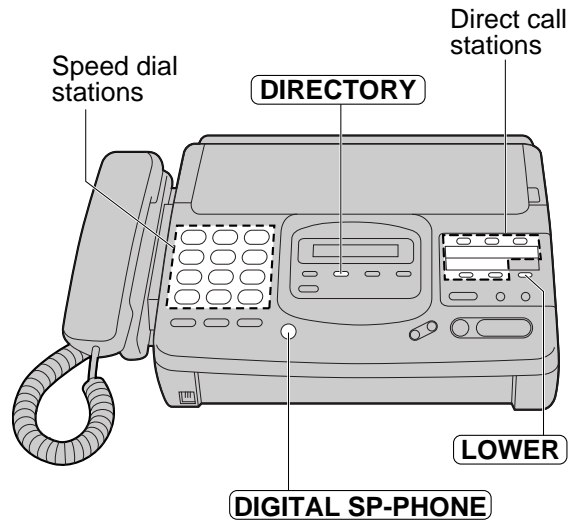

Transmitting documents using automatic dialing

1 Insert the documents FACE DOWN.

2a Using one-touch dialing:

For upper stations (1–5)
Press the desired direct call station key.

For lower stations (6–10)
Press **LOWER**, then press the desired direct call station key.

2b Using speed dialing:

Press **DIRECTORY**, then press **☐** and the desired 2-digit number (00–49).

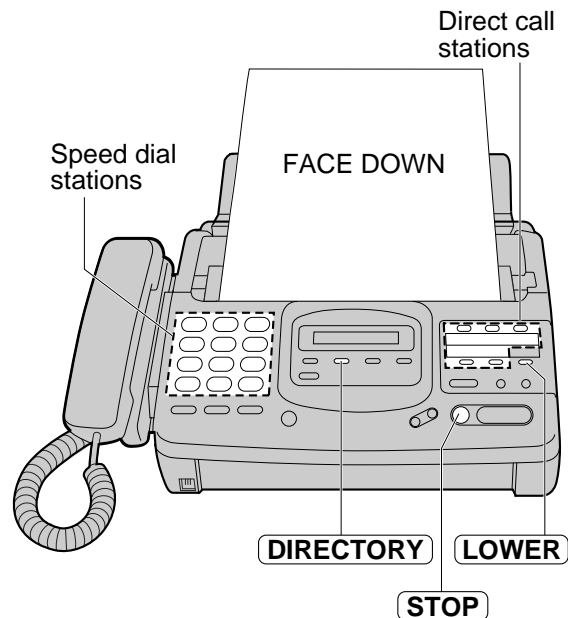

Fax auto redial

If there is no answer or the line is busy, the unit will automatically redial the number up to 5 times.

This feature is also available for;

—receive polling (p. 38)

—delayed transmission (p. 39)

During auto redial, the display shows;

Display: **WAITING REDIAL**

To cancel redialing, press **STOP**.

Electronic telephone directory

(selecting a station name in the directory)

The station names stored in memory are automatically registered into the electronic telephone directory in alphabetical order. You can make a fax or voice call by selecting the desired station name on the display.

If you wish to send a fax, insert the documents into the document tray first.

1 Press **DIRECTORY**.
 Display: SELECT INDEX

2 Press the dial key in which the first initial of the station name is assigned (see the index table below).

Example: To search a name with starting "N":
 Press **6** until the first station name with starting "N" is displayed. Press **▼** until the desired name is displayed.

OR

Press **▼** or **▲** repeatedly until the desired name is displayed.

3 Press **START/COPY/SET**.

- The unit will start dialing.
- If a document is fed into the unit, the unit will start transmission.

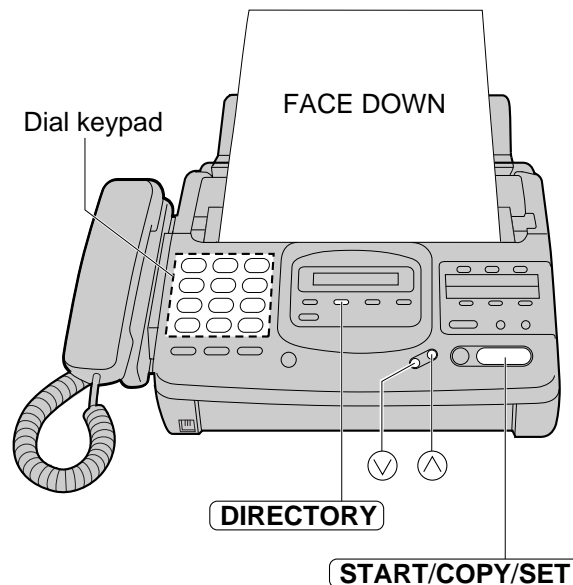

Advanced Operations

Dial key	Index	Dial key	Index
1	1	7	P, Q, R, S, 7
2	A, B, C, 2	8	T, U, V, 8
3	D, E, F, 3	9	W, X, Y, Z, 9
4	G, H, I, 4	0	0
5	J, K, L, 5	*	Other symbols
6	M, N, O, 6	#	(Used for speed dialing)

Telephone

Voice contact

(talking to the caller during or after fax reception or transmission)

You can have a conversation with the same call after the fax message is completed. This will save the extra expense and time of making another call.

This feature works only when the other party's unit is equipped with a voice contact feature.

Initiating voice contact

- 1 Press **DIGITAL SP-PHONE** while transmitting or receiving documents.

Display: VOICE STANDBY

- Your unit will call the other party with a distinctive ring.

- 2 When the other party answers, the unit will emit a distinctive ring.

Press **DIGITAL SP-PHONE** or lift the handset to start talking.

- If you initiate voice contact during transmission, you can talk after all the documents have been transmitted.
- If you initiate voice contact during reception, you can talk after the current page of the document is received.

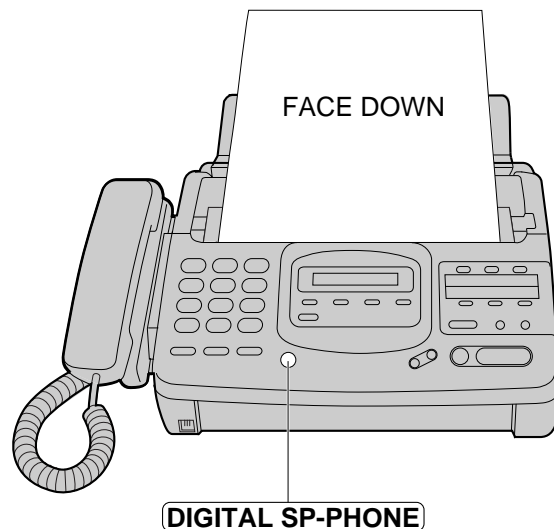

Receiving a request for voice contact

If the other party initiates voice contact, your unit will emit a distinctive ring after transmission or reception is completed.

When the distinctive ring is heard, press **DIGITAL SP-PHONE** or lift the handset, then start speaking.

Note:

- If you do not answer within 10 seconds of hearing the distinctive ring;
 - if in the ANS/FAX mode, your unit will play back a greeting message and record an incoming voice message.
 - if in the TEL/FAX, FAX or TEL mode, the line will be disconnected.

TONE, FLASH and REDIAL/PAUSE buttons

TONE button

The TONE (*) button is used for rotary pulse dial services and allows you to temporarily change from pulse to tone mode during a dialing operation. When you hang up, the unit will automatically return to the pulse mode.

FLASH button

The FLASH button functions as the hookswitch on a regular phone. If you misdial or dial another phone number, press the FLASH button firmly.

The FLASH button also allows you to use special features of a host exchange (if connected) or local telephone company services such as call waiting. For further details, contact your local telephone company.

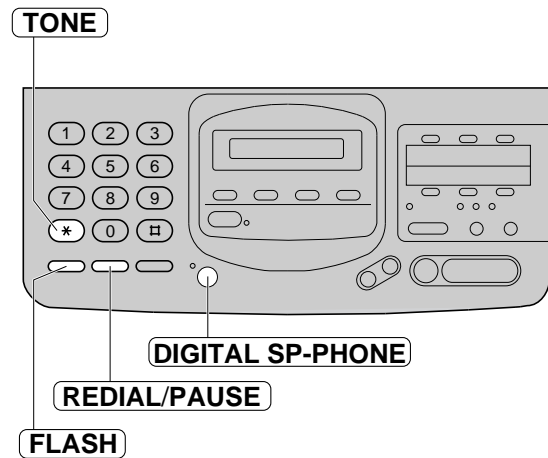

Note:

- TONE, FLASH and PAUSE can be stored into a phone number for automatic dialing.

Redialing the last number dialed

If the REDIAL/PAUSE button is pressed immediately after a dial tone is obtained, the last number dialed will be redialed.

1. Lift the handset or press **DIGITAL SP-PHONE**.
2. Press **REDIAL/PAUSE**.
 - If the line is busy when using the **DIGITAL SP-PHONE** button, the unit will automatically redial the number up to 14 times.

Entering pauses

If the REDIAL/PAUSE button is pressed during dialing, a pause will be inserted.

Example-1: When your unit is connected to a host exchange, insert a pause to get an outside line.

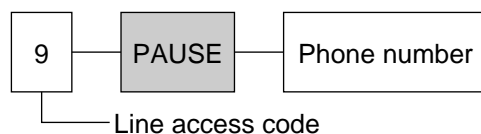

Example-2: If transmission errors occur when making an overseas transmission, add two pauses at the end of the phone number.

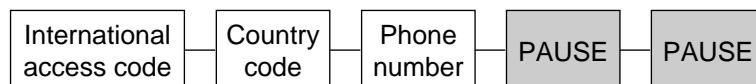

Special sending features

Polling (retrieving fax documents)

The polling feature allows you to receive a document from another compatible machine where you pay for the call. This saves the sending party the call charges.

Receive polling

To place a call and recover a document from another machine, follow the steps below. Make sure that no documents have been fed into your unit and that the other party's machine is ready for your call.

- 1 Press **MENU** until the following is displayed.

Display: POLLING

- 2 Press **START/COPY/SET**.

NO. =

- 3 Enter the phone number by using regular dialing, one-touch dialing, speed dialing or the electronic telephone directory (see page 35).

- 4 Press **START/COPY/SET**.

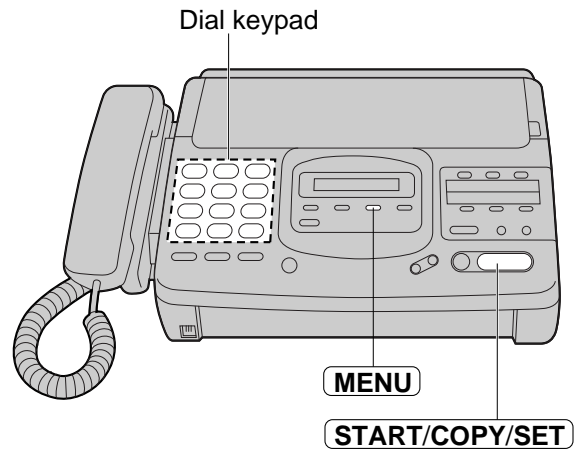

Transmit polling

A document stored in your unit can be recovered by another party's machine. To let other machines retrieve documents loaded on your unit, proceed as follows.

- 1 Insert the documents FACE DOWN.

- 2 Press **MENU** until the following is displayed.

Display: POLLED

- 3 Press **START/COPY/SET**.

MODE=OFF [V ^]

- 4 Press ∇ or \blacktriangle to select "ON".

MODE=ON [V ^]

- If this feature is not required, select "OFF".

- 5 Press **START/COPY/SET**.

POLLED ON

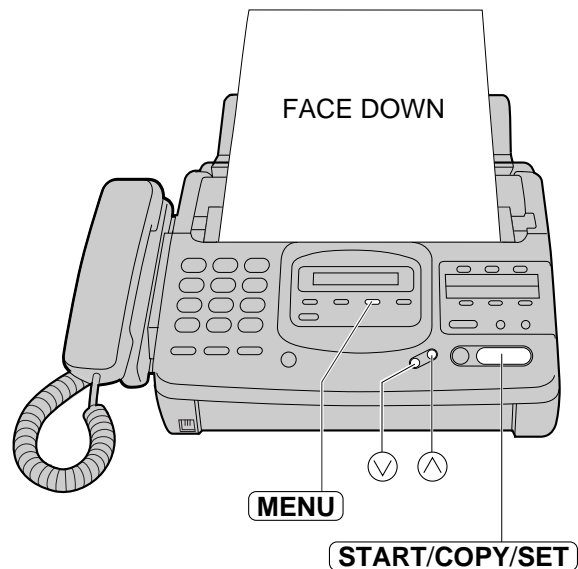

Note:

- This feature will not work when the unit is set to the TEL mode.
- The caller pays for the document transmission.
- When delayed transmission (see the next page) is set to ON, transmit polling is not available.

Delayed transmission

(sending a fax at a later time)

Using a built-in clock, this unit can send documents automatically at a specific time. This allows you to take advantage of low-cost calling hours offered by your telephone company. The delayed transmission can be reserved to take place up to 24 hours in advance.

- 1 Insert the documents FACE DOWN.
- 2 Press **MENU**.
Display: SYSTEM SET UP
- 3 Press *****, then press **2** **5**.
DELAYED XMT
- 4 Press **START/COPY/SET**.
MODE=OFF [v ^]
- 5 Press **v** or **^** to select "ON".
MODE=ON [v ^]
 - If this feature is not required, select "OFF".
- 6 Press **START/COPY/SET**.
NO. =
- 7 Enter the phone number by using regular dialing, one-touch dialing, speed dialing or the electronic telephone directory.
- 8 Press **START/COPY/SET**.
TIME=12:00AM
- 9 Enter the transmission start time.
Example: 11:00 PM
Press **1** **1** **0** **0**,
then press ***** to select PM.
 - You can select AM or PM by pressing *****.
- 10 Press **START/COPY/SET**.
- 11 Press **MENU**.
SEND AT 11:00PM

- When the programmed time has come, the unit will automatically start transmission.

Note:

- You can receive, transmit and copy documents while delayed transmission is set to ON.
- When transmit polling (see page 38) is ON, delayed transmission is not available.

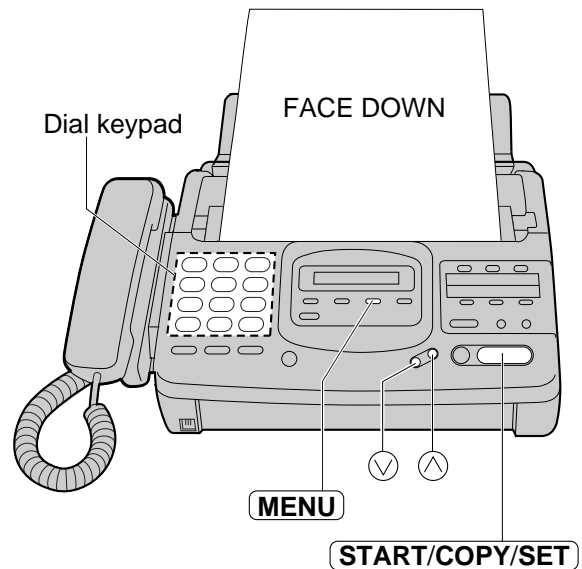

Special receiving features

Remote fax receiving (using an extension phone to receive a fax message)

If you have an extension phone on the same line, it is possible to receive a fax message. Use the extension phone to dial the remote fax activation code.

This saves you from going to the facsimile unit and pressing **START/COPY/SET**.

Important:

- To activate this feature, use a touch tone telephone as the extension phone and enter the remote fax activation code **FIRMLY**.
- The remote fax activation code is set to “*9” as a pre-selected setting.

Receiving using an extension phone

- 1** When a call is received, lift the handset of the extension phone.
- 2** When:
 - document reception is required,
 - a slow beep is heard, or
 - no sound is heard,enter the remote fax activation code **FIRMLY**.
- 3** Hang up the handset.
 - The facsimile unit is activated for reception.

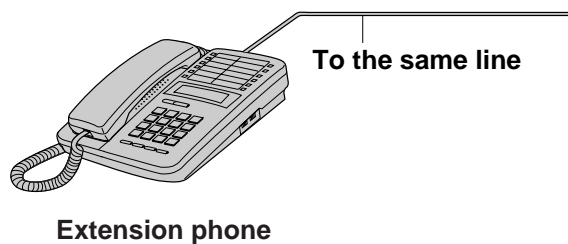

Changing the remote fax activation code _____

This code can be from 2 to 4 digits in length using numbers 0 through 9 and the character *.

- 1** Press **MENU**.
Display: SYSTEM SET UP
- 2** Press **▣**, then **4 1**.
REMOTE FAX ACT.
- 3** Press **START/COPY/SET**.
MODE=ON [v ^]
- 4** Press **⏴** or **⏵** to select the desired setting.
● If this feature is not required, select "OFF".
- 5** Press **START/COPY/SET**.
CODE=*9
- 6** Enter the new code.
- 7** Press **START/COPY/SET**.
- 8** Press **MENU**.

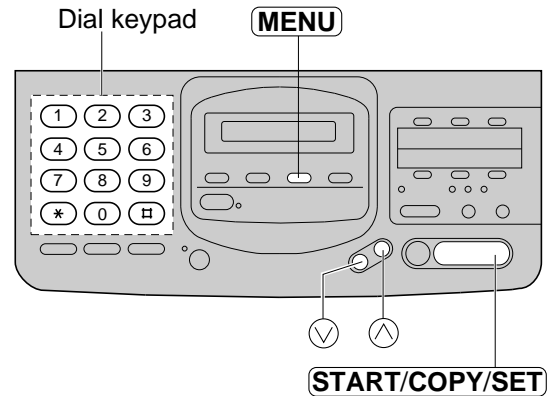

Note:

- Some special telephone company services will require you to press a service access code. If you subscribe to such services, all or part of the remote fax activation code must be different from the service access code.
- If the remote fax activation code is set to "0000", this feature does not work properly.

Junk mail prohibitor

(preventing the reception of unwanted fax documents)

This feature prevents reception from facsimile machines whose phone numbers are not stored in one-touch dialing and speed dialing.

Store the facsimile phone numbers from which you want to receive documents (see page 33).

Important:

- This feature does **not** work when:
 - the unit is set to the TEL mode,
 - manual reception is performed,
 - you have not stored any phone numbers in one-touch dialing or speed dialing, or
 - the other party does not program their facsimile telephone number correctly.

Setting the junk mail prohibitor

1 Press **MENU**.
Display: SYSTEM SET UP

2 Press **Ⓜ**, then **2** **4**.
JUNK MAIL PROH.

3 Press **START/COPY/SET**.
MODE=OFF [V ^]

4 Press **∇** or **▲** to select "ON".
MODE=ON [V ^]

- If this feature is not required, select "OFF".

5 Press **START/COPY/SET**.
PRINTING

- The unit will print a list of the telephone numbers from where the unit can receive documents. Confirm that the desired facsimile numbers are listed.

6 Press **MENU**.

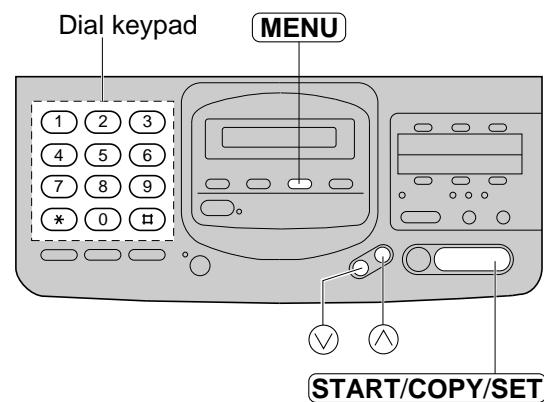

Receiving with a distinctive ring service

This feature can only be used by those who subscribe to a distinctive ring pattern service from their telephone company. For more information on the availability of this service, please contact your telephone company before setting this feature to ON.

The distinctive ring service gives you up to 3 phone numbers on a single telephone line, each having a different ringing pattern. When you use one of the phone numbers as a facsimile number, program the ringing pattern assigned for fax into your unit. When the unit detects a call matching the selected distinctive ringing pattern, the unit will activate depending on the receive mode setting.

Setting the distinctive ringing pattern

Program the ring pattern assigned for fax. Ringing patterns that can be programmed are;

- A: Standard ring (one long ring)
- B: Double ring (two short rings)
- C: Triple ring (short-long-short rings)
- D: Other triple ring (short-short-long rings)
- OFF: Turns off the ring pattern detection feature (pre-selected setting).

- 1 Press **MENU**.
Display: SYSTEM SET UP
- 2 Press **Ⓜ**, then **3 1**.
RING DETECTION
- 3 Press **START/COPY/SET**.
MODE=OFF [V ^]
- 4 Press **⏴** or **⏵** to select the ring pattern assigned for the facsimile number.
- 5 Press **START/COPY/SET**.
PRINTING
 - The unit will print an information list.
- 6 Press **MENU**.

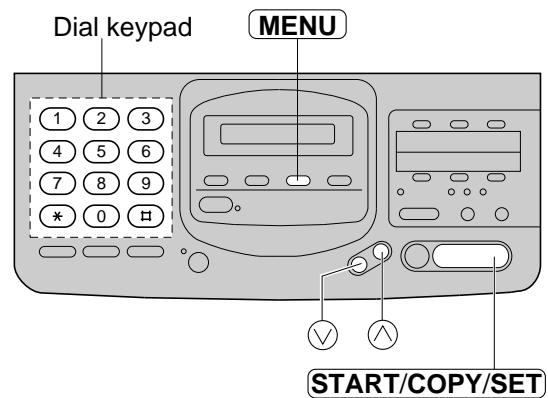

How the unit will answer in each receive mode

- ; **ANS/FAX mode:** When a distinctive ringing pattern that matches your selection is detected, the unit will automatically answer the line and activate the fax function to receive documents. If other ringing patterns are received, the unit will activate the fax function or the answering system depending on the call.
- ; **TEL/FAX mode:** When a distinctive ringing pattern that matches your selection is detected, the unit will automatically answer the line and activate the fax function to receive documents. If other ringing patterns are received, the unit will ring until you answer the call.
- ; **TEL mode:** In this mode, you have to answer all calls manually.
- ; **FAX mode:** In this mode, the unit will answer all calls and activate the fax function.

Note:

- The unit automatically answers a distinctive ring call after the second ring. To change the number of rings, change the FAX mode ring count (see "Setting the FAX mode ring count" on page 58) after setting the ringing pattern.

Answering device

Recording your own greeting messages

You can record your own greeting messages. The recording time is limited to 16 seconds for each message. We suggest recording a greeting message within 12 seconds for optimum performance.

- As for the ANS/FAX greeting message, you can choose from 16 seconds or 60 seconds of recording time (see page 63).

Suggested messages

ANS/FAX greeting message	<i>"This is (your name, business and/or telephone number). We are unable to answer right now. To send a fax, start transmission. To leave a message, speak after the beep. Thank you."</i>
TEL/FAX greeting message	<i>"This is (your name, business and/or telephone number). Please wait for someone to answer your call. To send a fax, start transmission."</i>
Mailbox 1 greeting message Mailbox 2 greeting message Mailbox 3 greeting message	<i>"This is (personal name). Please leave your name and message after the beep."</i>
Message transfer greeting	<i>"This is a transferred message from (your name, business and/or telephone number). Please enter your remote ID (mailbox 1-3 password) for remote operation."</i>

Note:

- If you do not record messages, pre-recorded messages will be played to the caller (see pages 25, 46 and 49).

Recording a greeting message

- 1 Open the station key panel.
- 2 Press **SELECT** until the following is displayed.
 - For the ANS/FAX greeting:
Display:
 - For the TEL/FAX greeting:
 - For mailbox 1-3 greeting:
Example: Mailbox 2
 - For the message transfer greeting:
- 3 Press **REC**.
 - A long beep will sound.
- 4 Speak clearly 20 cm (8 inches) away from the microphone.
 - The display will show the elapsed recording time.
Example: ANS/FAX greeting
- 5 When finished, press **STOP**.
 - The unit will repeat your message. Adjust the volume using **VOLUME**.

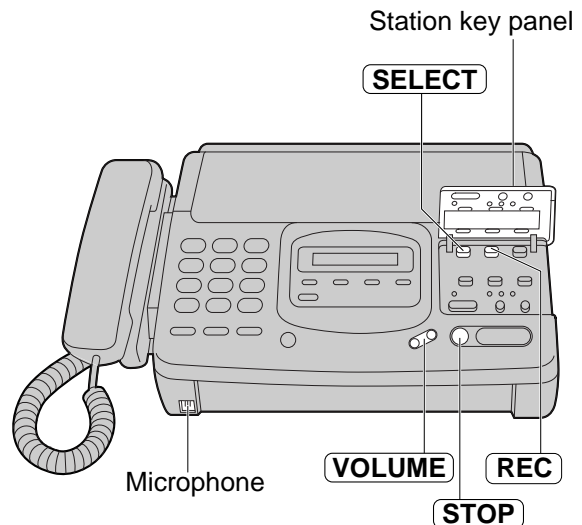

Note:

- If you make a mistake while recording, repeat from step 2.

Checking the greeting messages

- 1 Open the station key panel.
- 2 Press **SELECT** until the desired greeting is displayed.

Example: Mailbox 3 greeting

Display: BOX3-GREETING

- 3 Press **CHECK**.
 - After the beep, the unit will play back the message. Adjust the volume using **VOLUME**.

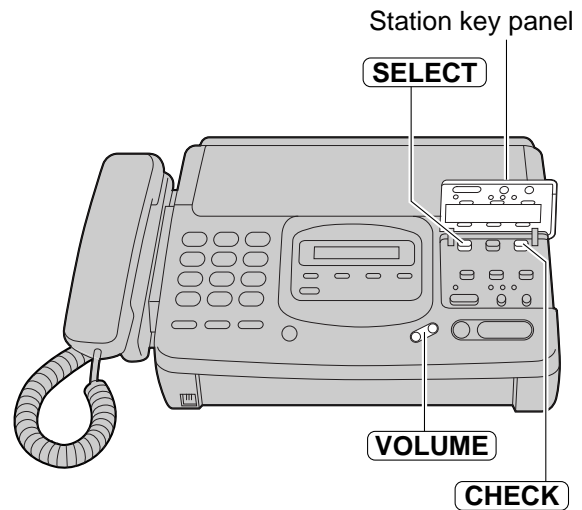

Erasing your own recorded greeting messages

- 1 Open the station key panel.
- 2 Press **SELECT** until the desired greeting is displayed.

Example: Mailbox 2 greeting

Display: BOX2-GREETING

- 3 Press **ERASE**.
ERASE OK?
↕
YES:PRESS SET

- 4 Press **START/COPY/SET**.
GREETING ERASED

- 5 Press **STOP**.

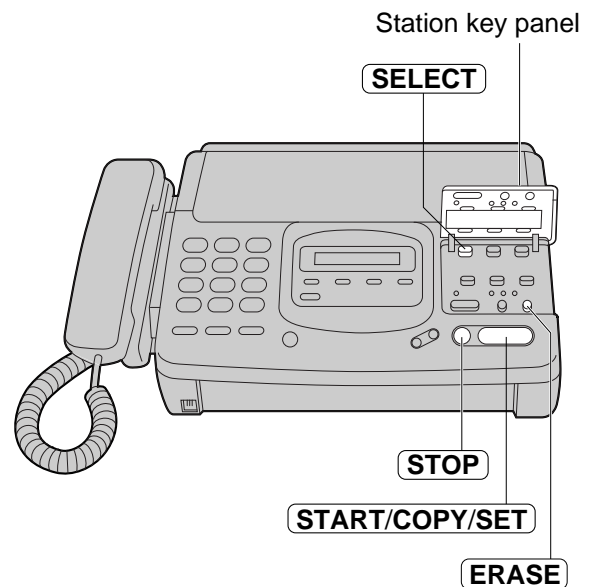

Note:

- If you erase your own recorded greeting messages, the pre-recorded greeting messages will be played instead.

Voice mailbox

(how callers can leave you private messages)

This unit has three mailbox memories. Your caller can leave a private message in a specific mailbox. Only the person who knows the password can retrieve a message from a mailbox. This feature is useful when you use this unit with other people and a caller would like to leave a message for a specific person.

To use a mailbox

1. Program the mailbox password if necessary (see below).
2. Inform the mailbox number to callers or the message will be recorded in common memory.
3. Set the unit to the ANS/FAX mode (see page 29).

Mailbox greeting messages

The unit has a pre-recorded greeting message for each memory. You can record your own greeting messages (see page 44).

Example of a pre-recorded greeting message (e.g. Mailbox 1)

*This is mailbox 1.
Please leave your name and message after the beep.*

Programming the mailbox password

Each mailbox password is pre-set as "555". If you do not program your own password, you do not need to enter a password to listen to the messages in a mailbox (see the next page).

If you wish to prevent other users from retrieving messages, program a password for your mailbox. Choose any 3-digit number except a number using digits 0 or 7.

The mailbox password must be different from the first 2 digits of the remote operation ID (page 52).

- 1** Press **MENU**.
Display: SYSTEM SET UP
- 2** For mailbox 1, press **☐**, then **5 1**.
BOX1 PASSWORD
For mailbox 2, press **☐**, then **5 2**.
BOX2 PASSWORD
For mailbox 3, press **☐**, then **5 3**.
BOX3 PASSWORD
- 3** Press **START/COPY/SET**.
NO. =
- 4** Enter the new password.
- 5** Press **START/COPY/SET**.
● To program other passwords, repeat from step 2.
- 6** Press **MENU**.

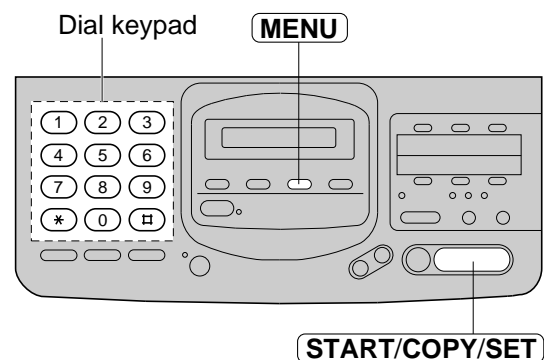

How incoming messages are recorded in a mailbox _____

- 1** Call your unit from a touch tone telephone.
 - The ANS/FAX greeting message will be played.
- 2** Press ***** and the desired mailbox number (**1**, **2** or **3**).
 - A mailbox greeting message will be played.
- 3** After the beep, leave a message.

Suggested message:

*Hello! We are unable to answer right now. To send a fax, please start transmission. To leave a voice message, please speak after the beep. To leave a private message, please press * and the desired mailbox number 1, 2, or 3. Thank you.*

This is mailbox (1–3). Please leave your name and message after the beep.

Recording a memo message and a telephone conversation

You can record a memo message and a telephone conversation into a mailbox. Press **MAIL BOX** until the desired mailbox number is displayed and follow the instructions on page 28.

- If you record a telephone conversation, choose the desired mailbox number after lifting the handset.

Listening to messages in a mailbox _____

When there is a new message in a mailbox,
—the mailbox number indicator will flash, and
—a slow beep will sound if the mailbox alert is set to ON (see the next page).

- 1** Press **MAIL BOX** until the desired mailbox number is displayed.

Example: Mailbox 2

Display: BOX2 02
- 2**
 - If you have not programmed your own password:
Press **NEW MSGS. PLAY BACK**.
or
 - If you program your own password:
Press **NEW MSGS. PLAY BACK**, then enter your password.

PASSWORD=

 - The unit will play back the new recorded messages.
- 3** To exit the mailbox, press **STOP**.

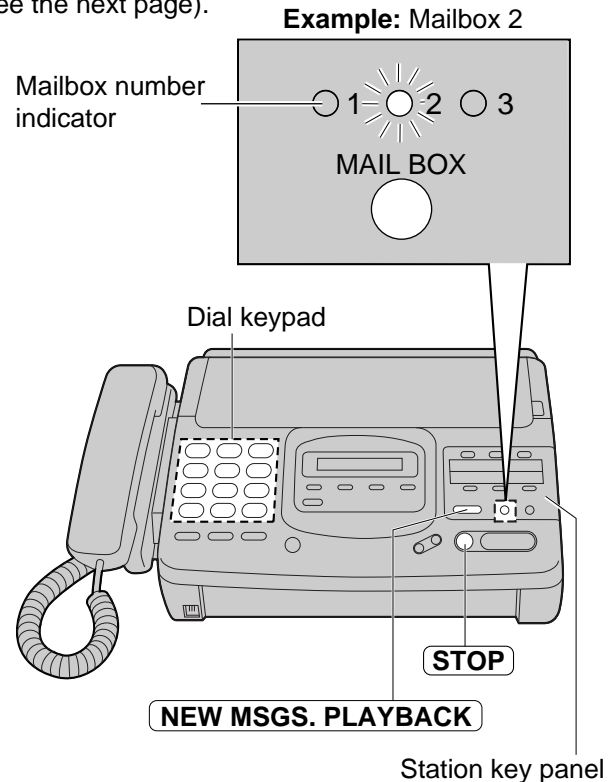

Note:

- **REPEAT**, **SKIP**, **STOP**, **QUICK** and **SLOW** can be used during playback (see page 27).
- To listen to all of the recorded messages, open the station key panel and press **ALL MSGS. PLAY BACK** in step 2.

Voice mailbox (cont.)

Erasing recorded messages in a mailbox

Erasing a specific message in a mailbox

Press **ERASE** while the message you want to erase is playing.

Erasing all messages in a mailbox

1 Press **MAIL BOX** until the desired mailbox number is displayed.

Example: Mailbox 1

Display: BOX1 02

2 Press **ERASE**.

BOX1 ERASE OK?
↕
YES:PRESS SET

3 Press **START/COPY/SET**.

ERASE COMPLETED

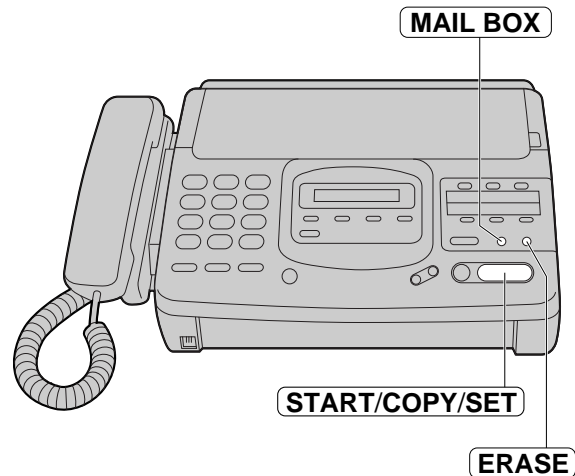

Setting the mailbox alert

This feature allows your unit to alert you with a slow beep that a caller's message is recorded in a mailbox.

1 Press **MENU**.

Display: SYSTEM SET UP

2 Press **#**, then **5** **0**.

MAIL BOX ALERT

3 Press **START/COPY/SET**.

MODE=OFF [v ^]

4 Press **∇** or **∧** to select "ON".

MODE=ON [v ^]

• If this feature is not required, select "OFF".

5 Press **START/COPY/SET**.

6 Press **MENU**.

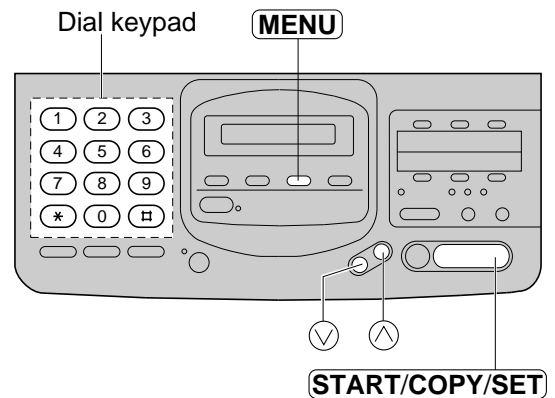

Transferring incoming call messages

This feature allows your unit to call a desired telephone number or pager phone number each time an incoming voice message is recorded in a common or mailbox memory.

You can choose either **Message Transfer** or **Pager Call** for each memory.

Message Transfer: Program the transfer phone number first. When an incoming message is recorded in your unit, the message will be transferred. You can retrieve the message during the same call by the remote operation.

Pager Call: Program the pager phone number first. When an incoming call is recorded, your pager will be called. Call your unit and retrieve the message by the remote operation.

- This feature is available in the ANS/FAX mode.
- For details on the remote operation, see page 51.
- Use a touch tone telephone to access your unit.

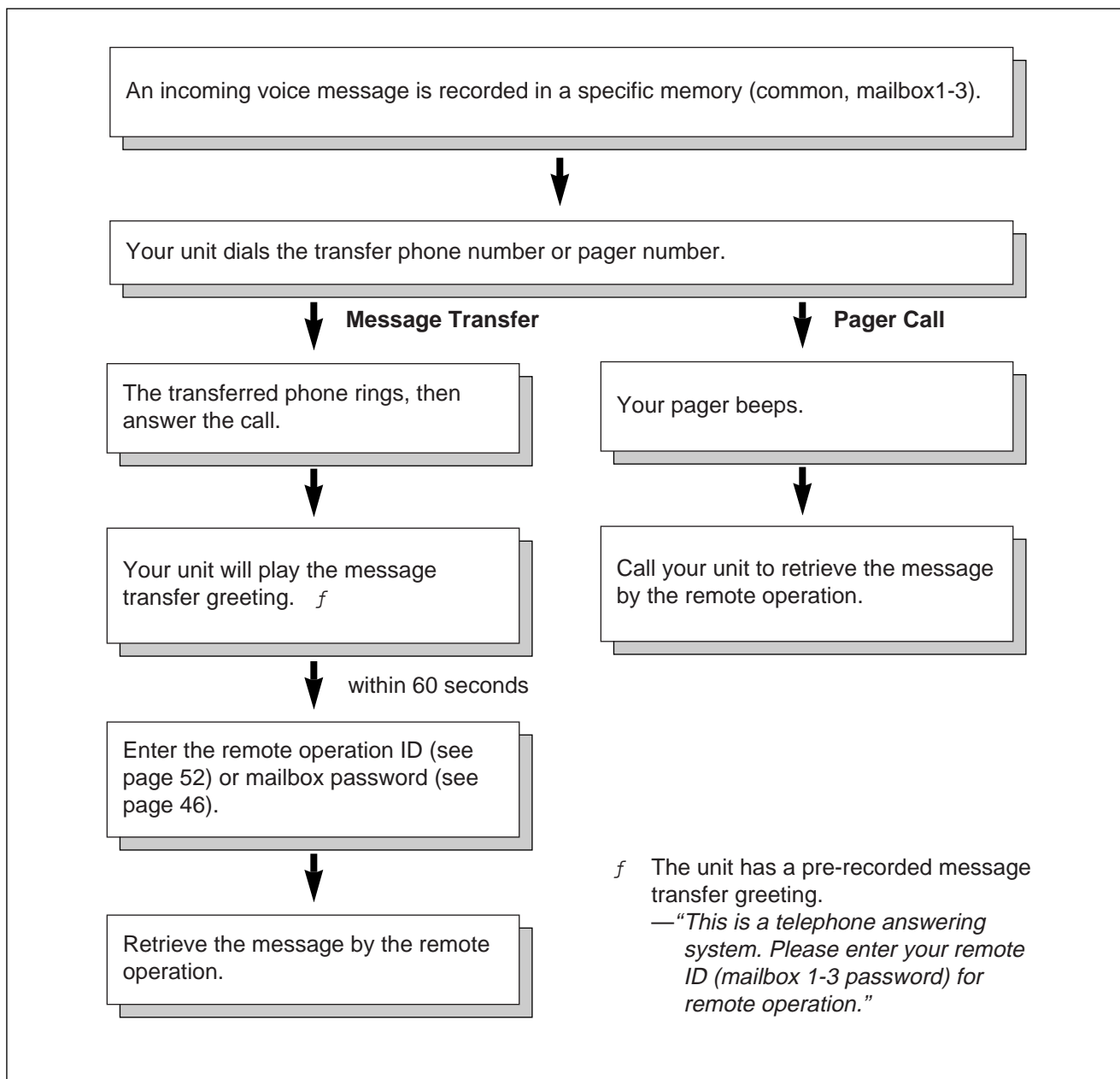

Transferring incoming call messages (cont.)

Setting the message transfer/pager call

1 Press **MENU**.
Display: SYSTEM SET UP

2 For common message transfer,
press **☐**, then **6 0**. COMMON MSG TRNSF

For mailbox 1 message transfer,
press **☐**, then **6 1**. BOX1 MSG TRNSF

For mailbox 2 message transfer,
press **☐**, then **6 2**. BOX2 MSG TRNSF

For mailbox 3 message transfer,
press **☐**, then **6 3**. BOX3 MSG TRNSF

3 Press **START/COPY/SET**.
MODE=OFF [V ^]

4 Press **∇** or **∧** to select the desired setting.
MESSAGE: Transfers incoming messages.
PAGER: Calls your pager.
OFF: Turns off this feature.

5 Press **START/COPY/SET**.
NO. =

6 a: If you selected "MESSAGE" in step 4:
Enter the telephone number where the message is to be transferred.

b: If you selected "PAGER" in step 4:
Enter your pager phone number.

- If this feature does not work properly, press **REDIAL/PAUSE** more than one time at the end of your pager phone number to extend the paging time.

If you wish to display a message on your pager, enter the message after your pager phone number and **REDIAL/PAUSE**. Programming methods may vary depending on the pager company. Contact your pager company for details.

- You may enter a total of 46 digits and/or pauses.

7 Press **START/COPY/SET**.

8 Press **MENU**.

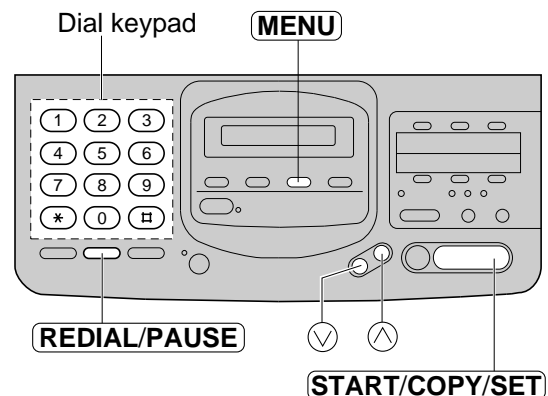

Note:

- This feature can be turned on/off remotely from a touch tone phone (see page 55).

Operating the answering device from a remote phone

The following operations are available from a remote location with a touch tone telephone.

Set the unit to the ANS/FAX mode in the AUTO RECEIVE mode before going out (see page 24).

Dial key	Remote command	Page	Dial key	Remote command	Page
0	Skips the greeting message	55	9	Stops re-recording of a greeting message	55
1	Repeats a message	54			
2	Skips a message	54	*4	Erases a specific message	54
4	New message playback	53	*5	Erases all messages	54
5	All message playback	53	81	Turns on message transfer/pager call for incoming messages	55
6	Room monitor	54			
7	Re-records a greeting message	55	82	Turns off message transfer/pager call for incoming messages	55

Remote operation card

Please cut out and carry this card for assistance with the remote operation use.

Mailbox Remote Operation	Notice of Remote Operation
<p>■ Recording a message in a mailbox:</p> <ol style="list-style-type: none"> 1. Call your unit. 2. Press * and the mailbox no. (1, 2 or 3). 3. Leave a message. <p>■ Retrieving messages from a mailbox:</p> <ol style="list-style-type: none"> 1. Call your unit. 2. Press * and the mailbox no. (1, 2 or 3). 3. Enter the mailbox password <input type="text"/> <input type="text"/> <input type="text"/>. 4. Press the remote command key (see the reverse side). 	<ul style="list-style-type: none"> ● The remote operation is available only from a touch tone phone when the unit is in the ANS/FAX mode. ● When the unit is in the TEL mode, call your unit and wait for 15 rings. The answering system will temporarily answer the line. Enter the remote operation ID during the greeting message. The unit will switch to the ANS/FAX mode. ● When you press any key, press firmly. ● To send a document, press *9. When a fax tone is heard, start transmission.

Fold here

Operating the answering device from a remote phone (cont.)

Programming the remote operation ID

The remote operation ID is used to access the answering device common memory. Choose any 3-digit number except a number using digits 0 or 7.

Make sure that the first 2-digits of the remote operation ID are different from the mailbox password (page 46).

- 1 Press **MENU**.
Display: SYSTEM SET UP
- 2 Press **⏏**, then **1 1**.
REMOTE ANS ID
- 3 Press **START/COPY/SET**.
ID=111
- 4 Enter the desired number.
- 5 Press **START/COPY/SET**.
- 6 Press **MENU**.

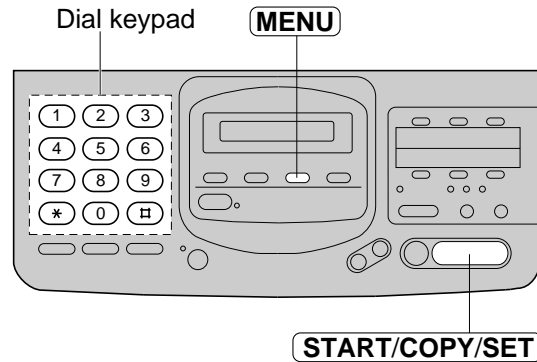

Answering Device Remote Operation

1. Call your unit.
2. Enter the remote operation ID during the greeting message.
3. Press the remote command key (see the right) within 4 seconds.
or
Wait for 4 seconds. All the recorded messages will be played back.

Key	Remote Command
0	Skips the greeting message
1	Repeats a message
2	Skips a message
4	New message playback
5	All message playback
6	Room monitor
7	Re-records a greeting message
9	Stops re-recording of a greeting message
*4	Erases a specific message
*5	Erases all messages
8 1	Message transfer/Pager call ON
8 2	Message transfer/Pager call OFF

Listening to messages in common memory _____

- 1 Call your unit.
- 2 Enter the remote operation ID during the ANS/FAX greeting playback.
— The voice guide will tell you the number of new recorded messages.
- 3 Press **4** to listen to the new recorded messages.
OR
Press **5** or wait for 4 seconds to listen to all of the recorded messages.

Example of the voice guide:

*3 new messages in common memory.
No new messages in mailbox.*

Listening to messages in a mailbox _____

- 1 Call your unit.
- 2 Press ***** and the desired mailbox number (**1**, **2** or **3**) during the ANS/FAX greeting playback.
- 3 Enter the mailbox password during the mailbox greeting message.
— If you have not programmed your own mailbox password, enter “555 (pre-selected setting)” as the mailbox password (see page 46).
— The voice guide will tell you the number of new recorded messages.
- 4 Press **4** to listen to the new recorded messages.
OR
Press **5** or wait for 4 seconds to listen to all of the recorded messages.

Example of mailbox greeting message:

*This is mailbox (1-3).
Please leave your name and message
after the beep.*

Example of the voice guide:

3 new messages in mailbox (1-3).

To listen to messages in another memory after playback

1. Press ***** and **0** (for common memory), then enter the remote operation ID.
or
Press ***** and the desired mailbox number (**1**, **2** or **3**), then enter the mailbox password during the mailbox greeting message.
 - If you have not programmed your own mailbox password, enter “555 (pre-selected setting)” as the mailbox password (see page 46).
2. Press **4** or **5** to play back messages.

Operating the answering device from a remote phone (cont.)

During playback

■ Repeating a message

Press **1** to play the current message.

—If you press **1** within 5 seconds of playback, the previous message will be played.

■ Skipping a message

Press **2** to play back the next message.

Note:

- If you hear the voice guide after playing back the messages, memory is full. Erase some or all of the messages.

Example of the voice guide:

Not enough recording time. Please erase unnecessary messages.

Erasing incoming messages from memory

■ Erasing a specific message from memory

Press *** 4** when the message you want to erase is played.

—A long beep and the voice guide will be played.
Then the unit will continue with the next message.

Example of the voice guide:

The message has been erased.

■ Erasing all messages from a specific memory

You can erase all of the recorded messages from the common memory and each mailbox memory. To erase all of the messages in a mailbox, you must first select the mailbox.

Press *** 5** when you want to erase the messages in a specific memory.

—A long beep and the voice guide will be heard.

Example of the voice guide:

All messages have been erased.

Other remote operations

■ Monitoring the room sound

You can monitor the sound in the room where the unit is installed.

Press **6** during the remote operation.

—You can monitor the room sound for about 30 seconds.

Note:

- After 30 seconds, a beep sounds. To continue monitoring, press **6** again within 10 seconds.

■ Recording a marker message

After playing back the recorded messages, you can leave an additional message.

Example of the voice guide:

1. Wait for the voice guide indicating the end of the remote operation.
2. Wait about 10 seconds until the voice guide is played.
3. Leave a message after the beep.

All messages have been played.

Please leave your name and message after the beep.

■ Re-recording a greeting message

You can change the contents of the greeting messages for the ANS/FAX mode and mailbox memories. To re-record a mailbox greeting message, you must first select the mailbox.

1. Press **7** to start recording during the remote operation.
—A long beep will sound.
2. Speak up to 16 seconds.
—If you pause for over 2 seconds, 6 beeps will sound and the recording will stop. Repeat from step 1 within 10 seconds.
3. When finished, press **9**.
—The new greeting message will be played.

■ Turning the message transfer/pager call on or off

You can remotely turn on or off the message transfer/pager call for incoming messages. You must program a transfer phone number or a pager number in advance (see page 50).

Example of the voice guide:

Press **8 1** to turn ON the message transfer/pager call during the remote operation.

*Message transfer is set.
Transfer phone number is 123456789.
or
Pager call is set.
Pager number is 098765432.*

Press **8 2** to turn OFF the message transfer/pager call.

*Message transfer is off.
or
Pager call is off.*

—If a transfer phone number or a pager number is not programmed, the voice guide will be played. You cannot turn this feature on.

*Transfer phone number is not set.
or
Pager number is not set.*

■ Skipping the greeting message

You can skip the greeting message.

Press **0** during the greeting message playback.
—The unit will skip the rest of the greeting message.

Special settings

Summary of user programmable features

Basic features

Code	Feature	Availabe settings	Pre-selected settings	Page
#01	SET DATE & TIME			13
#02	YOUR LOGO			14
#03	YOUR TELEPHONE NUMBER			15
#04	PRINT TRANSMISSION REPORT	ERROR, ON, OFF	ERROR	67
#05	AUTO RECEIVE MODE	ANS/FAX, FAX	ANS/FAX	29
#06	ANS/FAX RING COUNT	1-4 rings, TOLL SAVER, RINGER OFF	2 rings	57
#07	FAX RING COUNT	1–4 rings	2 rings	58
#08	MANUAL RECEIVE MODE	TEL, TEL/FAX	TEL	31
#09	TEL/FAX DELAYED RING	1–4 rings	2 rings	58
#10	RECORDING TIME	VOX (unlimited), 1 MIN	VOX	59
#11	REMOTE ANS ID		ID=111	52

Advanced features

Code	Feature	Availabe settings	Pre-selected settings	Page
#21	LOGO POSITION	OUT, IN	OUT	60
#22	JOURNAL AUTO PRINT	ON, OFF	ON	67
#23	OVERSEAS MODE	ON, OFF	OFF	60
#24	JUNK MAIL PROHIBITOR	ON, OFF	OFF	42
#25	DELAYED TRANSMISSION	ON, OFF	OFF	39
#26	AUTO CALLER LIST	ON, OFF	ON	69
#30	SILENT FAX RECOGNITION RING	3–6 rings	3 rings	59
#31	RING DETECTION	OFF, A, B, C, D	OFF	43
#39	LCD CONTRAST	NORMAL, DARKER	NORMAL	61
#41	REMOTE FAX ACTIVATION CODE	ON, OFF	ON/CODE= * 9	41
#42	MESSAGE ALERT	ON, OFF	OFF	61
#43	RECORDING TIME ALERT	ON, OFF	OFF	62
#46	FRIENDLY RECEPTION	ON, OFF	ON	62
#47	FAX VOICE GUIDANCE	ERROR, ON, OFF	ON	63
#50	MAIL BOX ALERT	ON, OFF	OFF	48
#51	BOX1 PASSWORD		555	46
#52	BOX2 PASSWORD		555	46
#53	BOX3 PASSWORD		555	46
#54	COMMON GREETING MESSAGE RECORDING TIME	16s, 60s	16s	63
#60	COMMON MESSAGE TRANSFER	OFF, MESSAGE, PAGER	OFF	50
#61	MAIL BOX1 MESSAGE TRANSFER	OFF, MESSAGE, PAGER	OFF	50
#62	MAIL BOX2 MESSAGE TRANSFER	OFF, MESSAGE, PAGER	OFF	50
#63	MAIL BOX3 MESSAGE TRANSFER	OFF, MESSAGE, PAGER	OFF	50
#70	FAX PAGER	ON, OFF	OFF	64
#80	SET DEFAULT	YES, NO	NO	65
#89	HANDSET SWITCH	USE HANDSET, NO HANDSET	USE HANDSET	65

Setting the ANS/FAX mode ring count

This feature determines the number of rings after which the unit answers a call in the ANS/FAX mode. You can choose from 1, 2, 3, 4, TOLL SAVER and RINGER OFF.

TOLL SAVER: When you call the unit from a remote location, the number of rings will tell you if there are any new voice messages. If the unit answers on the second ring, there is at least one new recorded message. If the unit answers on the fourth ring, there are no new recorded messages. To save the toll charges for the call, hang up immediately when you hear the third ring. The third ring indicates that there are no new messages.

RINGER OFF: The unit will answer without ringing.

Helpful hints:

- To answer a call before the unit does, increase the number of rings.
- If you have difficulty in receiving faxes from machines that have an automatic transmission feature, decrease the number of rings.

- 1 Press **MENU**.
Display: SYSTEM SET UP
- 2 Press **⏏**, then **0 6**.
ANS/FAX RING
- 3 Press **START/COPY/SET**.
RING=2 [v ^]
- 4 Press **v** or **^** to select the desired setting.
- 5 Press **START/COPY/SET**.
- 6 Press **MENU**.

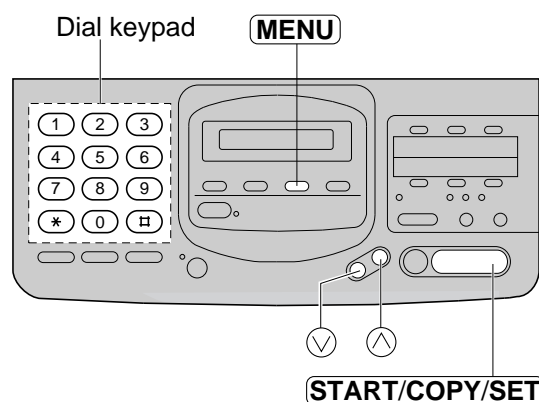

Setting the FAX mode ring count

This feature determines the number of rings after which the unit answers a call in the FAX mode. You can choose from 1 to 4 rings.

Helpful hints:

- To answer a call before the unit does, increase the number of rings.
- If you have difficulty in receiving faxes from machines that have an automatic transmission feature, decrease the number of rings.

- 1 Press **MENU**.
Display: SYSTEM SET UP
- 2 Press **⏏**, then **0 7**.
FAX RING
- 3 Press **START/COPY/SET**.
RING=2 [V ^]
- 4 Press **⏴** or **⏵** to select the desired number.
- 5 Press **START/COPY/SET**.
- 6 Press **MENU**.

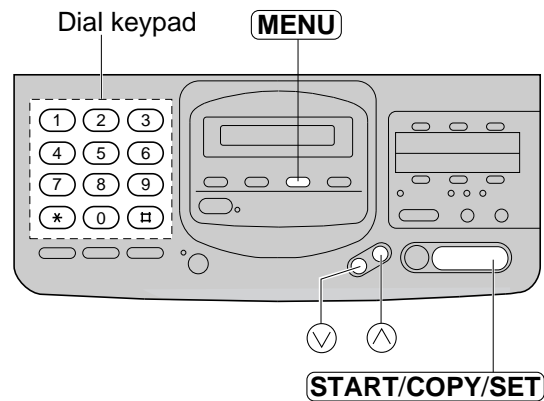

Setting the TEL/FAX mode ring count

This feature determines the number of rings after which the unit automatically answers a call in the TEL/FAX mode.

You can choose from 1 to 4 rings.

- 1 Press **MENU**.
Display: SYSTEM SET UP
- 2 Press **⏏**, then **0 9**.
TEL/FAX RING
- 3 Press **START/COPY/SET**.
RING=2 [V ^]
- 4 Press **⏴** or **⏵** to select the desired number.
- 5 Press **START/COPY/SET**.
- 6 Press **MENU**.

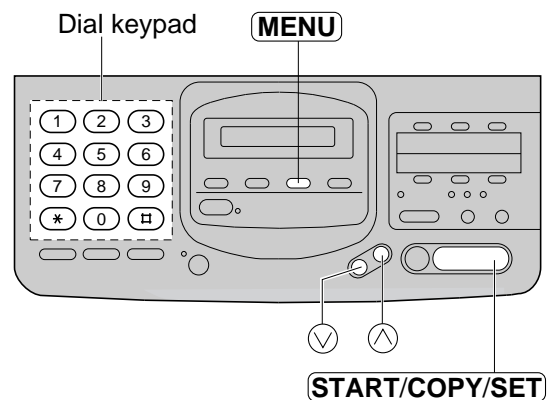

Note:

- If you increase the number of rings, you may not be able to receive documents from some older types of facsimile machines.

Setting the silent fax recognition ring count

When a fax call is received in the TEL/FAX mode, the unit will automatically activate the fax function without ringing. If the unit detects a voice call, it will ring. If a voice call is not answered within the selected number of rings (3 to 6 rings), the unit will switch back to the fax mode. This is for machines that do not send a calling tone.

- 1 Press **MENU**.
Display: SYSTEM SET UP
- 2 Press **#**, then **3 0**.
SILENT FAX RING
- 3 Press **START/COPY/SET**.
RING=3 [v ^]
- 4 Press **v** or **^** to select the desired number.
- 5 Press **START/COPY/SET**.
- 6 Press **MENU**.

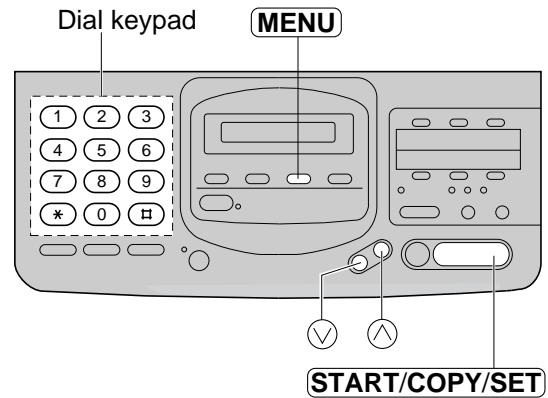

Note:

- If you increase the number of rings, you may not be able to receive documents from some older types of facsimile machines.

Changing the caller's recording time

You can change the length of recording time for an incoming message.

VOX (unlimited): The unit records an incoming message as long as the caller speaks (pre-selected setting).

1 MIN (1 minute): The unit will record each incoming message up to 1 minute.

- 1 Press **MENU**.
Display: SYSTEM SET UP
- 2 Press **#**, then **1 0**.
RECORDING TIME
- 3 Press **START/COPY/SET**.
MODE=VOX [v ^]
- 4 Press **v** or **^** to select the desired setting.
- 5 Press **START/COPY/SET**.
- 6 Press **MENU**.

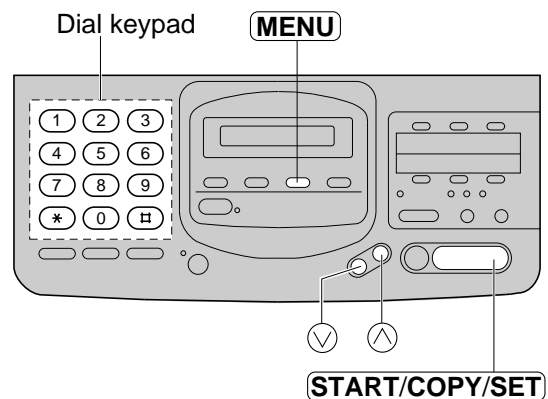

Changing the logo print position

The logo, telephone number, date, time and page number can be printed on the transmitted document from your unit in the following manner.

OUT: Outside of the transmitted document's paper size (pre-selected setting).

IN: Inside of the transmitted document's paper size.

- 1 Press **MENU**.
Display: SYSTEM SET UP
- 2 Press **⏏**, then **2** **1**.
LOGO POSITION
- 3 Press **START/COPY/SET**.
MODE=OUT [v ^]
- 4 Press **v** or **^** to select the desired setting.
- 5 Press **START/COPY/SET**.
- 6 Press **MENU**.

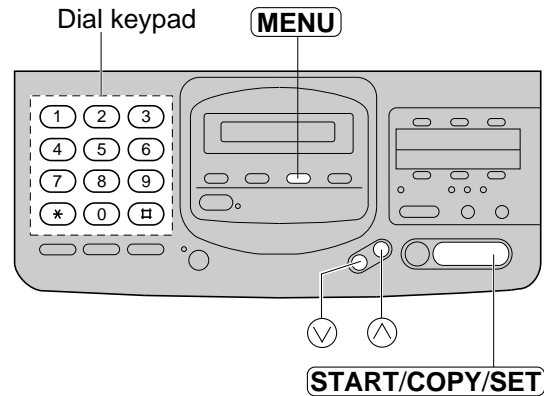

Sending documents overseas

You may experience difficulty in transmitting documents overseas. This feature will make sending documents easier as the transmission speed is slowed down. Before starting the transmission procedure, follow the steps below.

- 1 Press **MENU**.
Display: SYSTEM SET UP
 - 2 Press **⏏**, then **2** **3**.
OVERSEAS MODE
 - 3 Press **START/COPY/SET**.
MODE=OFF [v ^]
 - 4 Press **v** or **^** to select "ON".
MODE=ON [v ^]
- If this feature is not required, select "OFF".
- 5 Press **START/COPY/SET**.
 - 6 Press **MENU**.

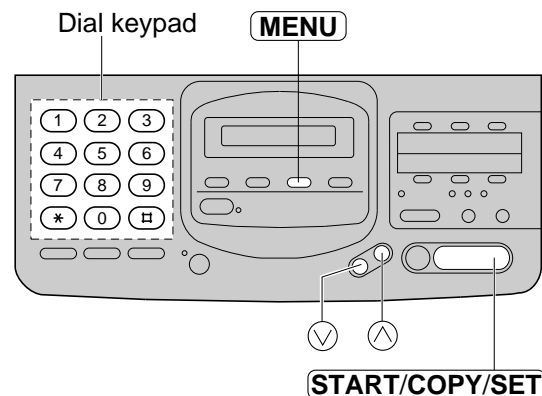

Note:

- After transmission, this feature will be turned off automatically.

Changing the display contrast

Use this feature to adjust the brightness of the display.

NORMAL: (Pre-selected setting)

DARKER: Used when the display contrast is too light.

- 1 Press **MENU**.
Display: SYSTEM SET UP
- 2 Press **⏏**, then **3 9**.
LCD CONTRAST
- 3 Press **START/COPY/SET**.
MODE=NORMAL [v ^]
- 4 Press **v** or **^** to select the desired setting.
- 5 Press **START/COPY/SET**.
- 6 Press **MENU**.

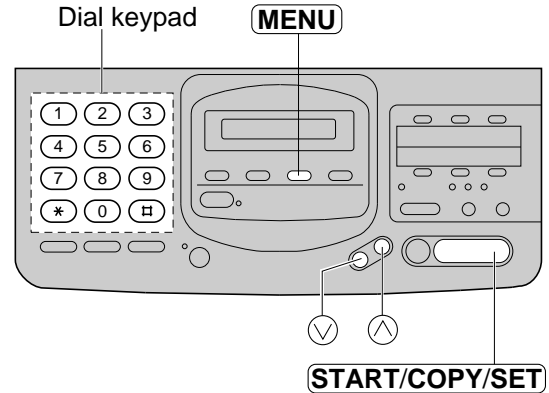

Setting the message alert

When this feature is on, the unit will let you know with a slow beep that a caller's message is recorded in common memory.

- 1 Press **MENU**.
Display: SYSTEM SET UP
- 2 Press **⏏**, then **4 2**.
MESSAGE ALERT
- 3 Press **START/COPY/SET**.
MODE=OFF [v ^]
- 4 Press **v** or **^** to select "ON".
MODE=ON [v ^]
 - If this feature is not required, select "OFF".
- 5 Press **START/COPY/SET**.
- 6 Press **MENU**.

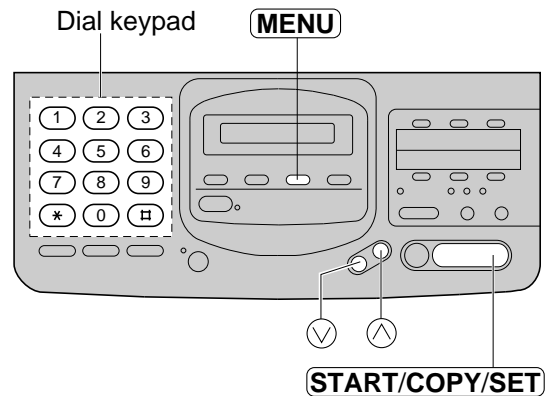

Setting the recording time alert

With this feature, when the remaining time to record incoming messages becomes less than 60 seconds, the unit will alert the user with a slow beep.

- 1 Press **MENU**.
Display: SYSTEM SET UP
- 2 Press **⏏**, then **4** **3**.
REC. TIME @ALERT
- 3 Press **START/COPY/SET**.
MODE=OFF [V ^]
- 4 Press **⏴** or **⏵** to select "ON".
MODE=ON [V ^]
 - If this feature is not required, select "OFF".
- 5 Press **START/COPY/SET**.
- 6 Press **MENU**.

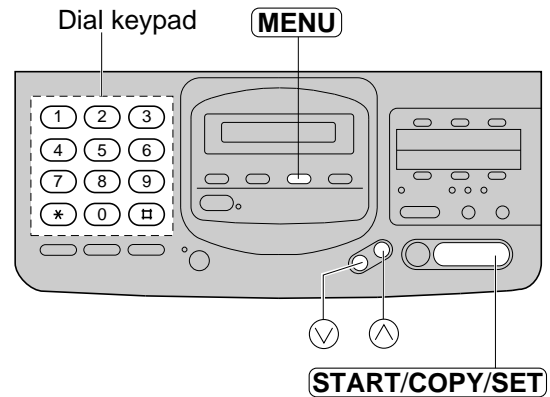

Setting the friendly reception

The friendly reception feature allows you to receive fax documents automatically without pressing **START/COPY/SET**. See page 23 for further details.

If you set this feature to OFF, you will have to press **START/COPY/SET** to receive fax documents each time a fax is received.

- 1 Press **MENU**.
Display: SYSTEM SET UP
- 2 Press **⏏**, then **4** **6**.
FRIENDLY RCV
- 3 Press **START/COPY/SET**.
MODE=ON [V ^]
- 4 Press **⏴** or **⏵** to select the desired setting.
- 5 Press **START/COPY/SET**.
- 6 Press **MENU**.

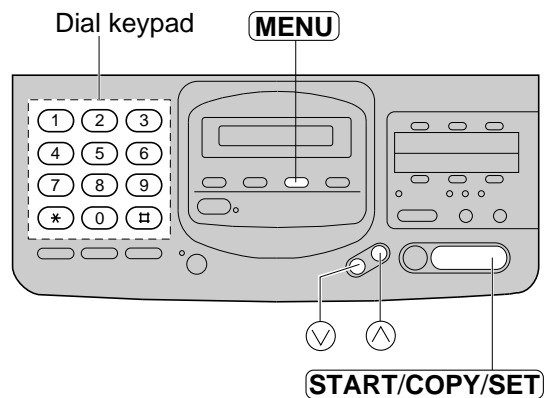

Note:

- If you set the fax voice guidance feature to OFF (see the next page), you cannot hear the friendly reception message.

Setting the fax voice guidance

One of the following choices is available (see pages 19 and 23).

ON: The voice guidance message regarding fax transmission/reception and friendly reception will be heard after every transaction (pre-selected setting).

OFF: The fax voice guidance will not be heard.

ERROR: The fax voice guidance will be heard only when fax transmission/reception and friendly reception fail.

- 1 Press **MENU**.
Display: SYSTEM SET UP
- 2 Press **Ⓜ**, then **4** **7**.
FAX GUIDANCE
- 3 Press **START/COPY/SET**.
MODE=ON [V ^]
- 4 Press **▽** or **△** to select the desired setting.
- 5 Press **START/COPY/SET**.
- 6 Press **MENU**.

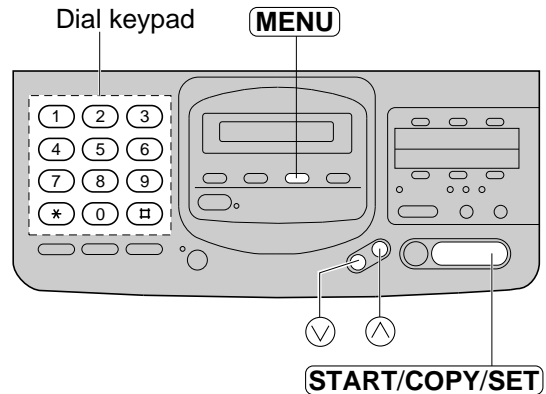

Changing the recording time for the ANS/FAX greeting message

You can choose from 16 seconds or 60 seconds of recording time.

- 1 Press **MENU**.
Display: SYSTEM SET UP
- 2 Press **Ⓜ**, then **5** **4**.
GREETING TIME
- 3 Press **START/COPY/SET**.
MODE=16s [V ^]
- 4 Press **▽** or **△** to select the desired setting.
- 5 Press **START/COPY/SET**.
- 6 Press **MENU**.

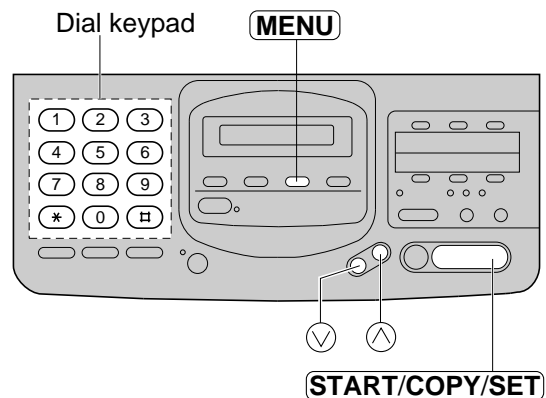

Note:

- If you change the greeting message time to 60 seconds, we recommend that you inform the caller in the ANS/FAX greeting message to press * 9 before starting fax transmission.
- If you change the greeting message time to 16 seconds from 60 seconds, your recorded ANS/FAX greeting message will be deleted. Re-record a greeting message (see page 44).

Signaling your pager that you have received a fax document

This feature allows your unit to call your pager when your unit receives a fax message.
This feature only works with an automatic pager.

1 Press **MENU**.
Display: SYSTEM SET UP

2 Press **Ⓜ**, then **7 0**.
FAX PAGER

3 Press **START/COPY/SET**.
MODE=OFF [V ^]

4 Press **∇** or **▲** to select "ON".
MODE=ON [V ^]

- If this feature is not required, select "OFF".

5 Press **START/COPY/SET**.
NO. =

6 Enter your pager phone number.
● If this feature does not work properly, press **REDIAL/PAUSE** more than one time at the end of your pager phone number to extend the paging time.

If you wish to display a message on your pager, enter the message after your pager phone number and **REDIAL/PAUSE**.

Programming methods may vary depending on the pager company. Contact your pager company for details.

- You can enter a total of 46 digits and/or pauses.

7 Press **START/COPY/SET**.

8 Press **MENU**.

Note:

- This feature is not available when the receive mode is set to the TEL mode.

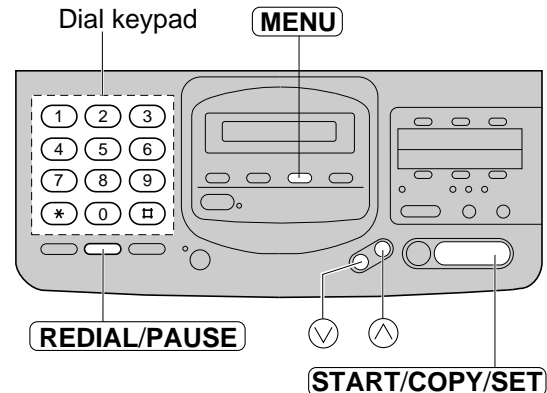

Resetting the advanced features

Use this feature to return the advanced features (see page 56) to their pre-selected settings.

- 1 Press **MENU**.
Display: SYSTEM SET UP
- 2 Press **⏏**, then **8 0**.
SET DEFAULT
- 3 Press **START/COPY/SET**.
RESET=NO [v ^]
- 4 Press **⏴** or **⏵** to select "YES".
RESET=YES [v ^]
- 5 Press **START/COPY/SET**.
RESET OK?

• If this feature is not required, press **STOP**.

- 6 Press **START/COPY/SET** again for confirmation.
RESET COMPLETED
- 7 Press **MENU**.

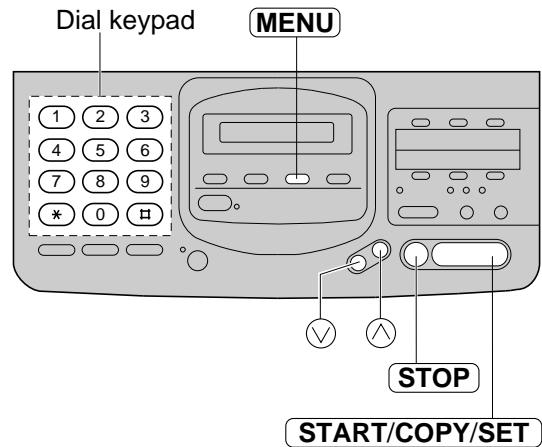

Setting the handset switch

This unit can work without the handset and handset cradle. When you do not use the handset and cradle, set this feature to "NO HANDSET".

USE HANDSET: Choose when you use the handset and handset cradle (pre-selected setting).

NO HANDSET: Choose when you do not use the handset and handset cradle.

- 1 Press **MENU**.
Display: SYSTEM SET UP
- 2 Press **⏏**, then **8 9**.
HANDSET SWITCH
- 3 Press **START/COPY/SET**.
USE HANDSET [v ^]
- 4 Press **⏴** or **⏵** to select the desired setting.
- 5 Press **START/COPY/SET**.
- 6 Press **MENU**.

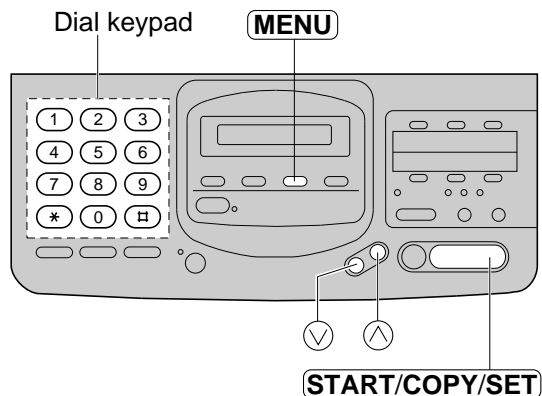

Note:

- After you select "NO HANDSET", disconnect and connect the power cord.

Printing reports and lists

You can print out the following reports and lists from your unit.

Basic feature list— provides you with the current settings of the basic features (see page 56).

Advanced feature list— provides you with the current settings of the advanced features (see page 56).

Telephone number list— provides you with phone numbers and their station names which are stored in automatic dialing. Phone number codes are as shown below.

P: A pause has been entered.

F: A flash has been entered.

[]: A secret phone number has been entered. (The telephone number is not printed.)

Journal report— keeps records of fax transmissions and receptions (see page 68 for a sample of the report). This report will be printed automatically after every 35 fax communications, but also can be printed manually. You can change the setting of the journal auto print feature (see the next page).

Transmission report—provides you with a printed record of the fax transmission result (see the next page and page 68 for a sample of the report).

Caller list— is useful for keeping a record of the last 20 callers after subscribing to Caller ID Service. For further details, see page 69.

How to print reports and lists

1 Press **MENU** until the following is displayed.

Display: PRINT LIST

2 For the **basic feature list**, press **[]**, then **[1]**.

BASIC LIST

For the **advanced list**, press **[]**, then **[2]**.

ADVANCED LIST

For the **telephone number list**, press **[]**, then **[3]**.

TEL NO. LIST

For the **journal report**, press **[]**, then **[4]**.

JOURNAL REPORT

For the **caller list**, press **[]**, then **[5]**.

CALLER LIST

3 Press **START/COPY/SET** to start printing.

PRINTING

● To interrupt printing, press **STOP**.

4 After printing, press **MENU**.

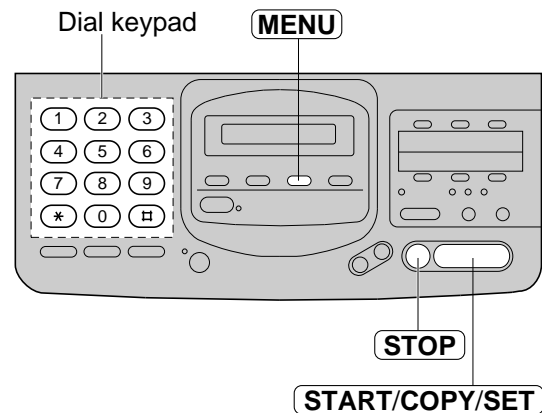

Setting the transmission report printing

One of the following choices is available.

ERROR: The transmission report will print out only when fax transmission fails (pre-selected setting).

ON: The report will always print out, indicating whether fax transmission is successful or not.

OFF: The report will not print.

- 1 Press **MENU**.
Display: SYSTEM SET UP
- 2 Press **Ⓜ**, then **0 4**.
TX-REPORT MODE
- 3 Press **START/COPY/SET**.
MODE=ERROR [v ^]
- 4 Press **v** or **^** to select the desired setting.
- 5 Press **START/COPY/SET**.
- 6 Press **MENU**.

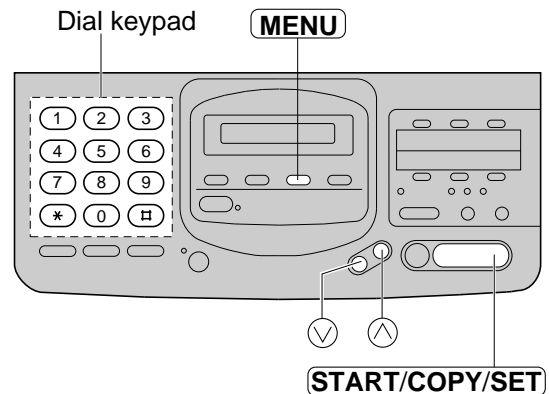

Setting the journal report to print automatically

This unit will automatically print a journal report after every 35 fax communications. After printing, the journal report will still remain in memory and the oldest communication will be erased when a new communication occurs.

When this feature is OFF, the unit will store the records of the last 35 fax communications, but the unit will not print the journal report.

- 1 Press **MENU**.
Display: SYSTEM SET UP
- 2 Press **Ⓜ**, then **2 2**.
AUTO JOURNAL
- 3 Press **START/COPY/SET**.
MODE=ON [v ^]
- 4 Press **v** or **^** to select the desired setting.
- 5 Press **START/COPY/SET**.
- 6 Press **MENU**.

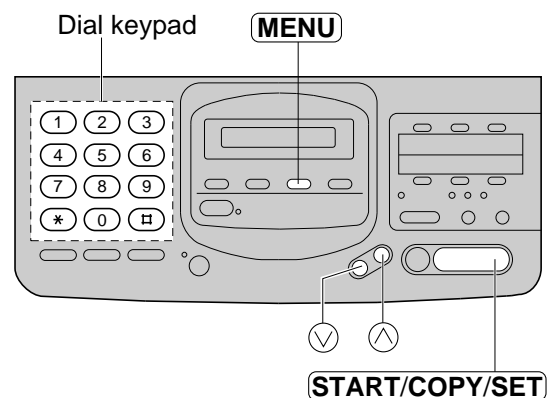

Printing reports and lists (cont.)

Sample of a journal report

y JOURNAL z		JAN. 25 1997 05:22PM						
NO.	OTHER FACSIMILE	START TIME	USAGE TIME	MODE	PAGES	RESULT	*CODE	
01	1234567	JAN. 21 02:14PM	00'25	TX	01	OK		
02	9998765	JAN. 21 02:17PM	00'38	TX	02	OK		
03	2121444	JAN. 21 02:18PM	00'28	RX	01	OK		
04	555556677	JAN. 22 10:35AM	00'58	TX	03	COMMUNICATION ERROR	(43)	
05			01'50	TX	05	OK		
				RX	03	OK		

Communication messages (see below.)
Error code (for service personnel use only)

Sample of a transmission report

y XMT REPORT z		JAN. 20 1997 01:19PM						
NO.	OTHER FACSIMILE	START TIME	USAGE TIME	MODE	PAGES	RESULT	*CODE	
01	1234567	JAN. 20 01:18PM	00'51	TX	00	COMMUNICATION ERROR	(43)	

Communication messages on the report

When a problem has occurred, one of the following messages will be printed on the transmission and journal reports.

PRINTED MESSAGE	CODE	MEANING
COMMUNICATION ERROR	41-47 FF	● A transmission or reception error occurred. Try again or check with the other party.
DOCUMENT JAMMED	—	● A document is jammed. Remove the jammed document (p. 74).
JUNKMAIL PROH. REJECT	—	● The junk mail prohibitor of your unit rejected fax reception.
MEMORY FULL	—	● The document was not received due to memory being full.
NO DOCUMENT	—	● The document was not fed into the unit properly. Try again.
NO RESPONSE	—	<ul style="list-style-type: none"> ● The receiving unit was busy or ran out of recording paper. Try again. ● The START/COPY/SET button was pressed when the document was not set properly. Set the document properly and press the START/COPY/SET button after confirming the fax tone. ● The other party's machine is not a facsimile. Check with the other party.
PAPER JAMMED	—	● The recording paper is jammed. Clear the jammed paper (p. 73).
PAPER OUT	—	● The unit ran out of recording paper. Install a recording paper roll (p. 9).
PRESSED THE STOP KEY	—	● The STOP button was pressed, and fax communication was canceled.
PRINTER OVERHEATED	—	● The printer is overheated. Let the unit cool down.
THE COVER WAS OPENED	—	● The back cover was open. Close it and try again.
OK	—	● Fax communication was successful.

Setting the caller list to print automatically

This unit will automatically print a caller list after every 20 calls. After printing, the caller list will still remain in memory and the oldest communication will be erased when a new communication is received.

- 1 Press **MENU**.
Display: SYSTEM SET UP
- 2 Press **⏏**, then **2** **6**.
AUTO CALL. LIST
- 3 Press **START/COPY/SET**.
MODE=ON [v ^]
- 4 Press **v** or **^** to select the desired setting.
- 5 Press **START/COPY/SET**.
- 6 Press **MENU**.

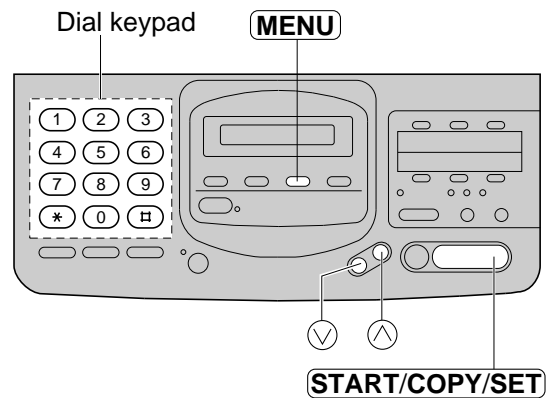

Sample of a caller list

y CALLER LIST z				
JAN. 04 1997 04:37PM				
NO.	NAME	TEL NO.	TIME OF CALL	ANSWER
01	ROGER DAVIS	345-3809	JAN. 01 02:35PM	FAX
02	SHARON SMITH	103-2238	JAN. 02 08:35AM	TAM
03	JOHN	345-3809	JAN. 02 02:35PM	TEL
04	MIKE SHARON	103-5555	JAN. 04 08:45AM	

Special Settings

- The NAME/TEL NO./TIME OF CALL are received through a Caller ID Service (see page 17).
- ANSWER : How the call was received by the unit.
 - FAX: facsimile
 - TAM: telephone answering machine
 - TEL: telephone
 - Blank: There was no response.

Troubleshooting

Error messages on the display

If the unit detects a problem, one or more of the following messages will appear on the display.

DISPLAY MESSAGE	CAUSE & REMEDY
CALL SERVICE	● There is something wrong with the unit. Contact our service personnel (see page 78).
CHECK COVER	● The back cover is open. Close it.
CHECK CRADLE	● The handset and handset cradle have been removed. —When you want to use the handset and cradle, install the handset cradle correctly (see page 8). —When you do not use them, set the handset switch to “NO HANDSET” (see page 65). Then disconnect and connect the power cord again.
CHECK DOCUMENT	● The document is not fed into the unit properly. Reinsert the document. If the misfeeding occurs frequently, clean the document feeder rollers inside the unit (see page 75). If the problem remains, adjust the feeder pressure (see page 74).
CHECK MEMORY	● Memory (phone numbers, parameters, etc.) has been erased. Re-program.
FAX IN MEMORY	● The unit has (a) document(s) in memory. See the other message’s instructions to print out the document(s).
MEMORY FULL	● There is no room left in memory to record a voice message. Erase some or all of the messages (see pages 26 and 48). ● The memory is full of received documents. Install a new recording paper roll (see page 9), or clear the jammed paper (see page 73).
NO RESPONSE	● The receiving unit is busy or ran out of recording paper. Try again.
OUT OF PAPER	● The unit ran out of recording paper. Install a recording paper roll (see page 9).
PAPER JAMMED	● A recording paper jam occurred. Clear the jammed paper (see page 73).
POLLING ERROR	● The other fax machine does not have the polling function. Check with the other party.
REDIAL TIME OUT	● The receiving unit is busy or ran out of recording paper. Try again.
REMOVE DOCUMENT	● The document is jammed. Remove the jammed document (see page 74). ● Attempted to transmit a document longer than 600 mm (23 5/8"). Press the STOP button and remove the document (see page 74). Divide the document into two or more sheets and try again.
TRANSMIT ERROR	● A transmission error occurred. Try again.
UNIT OVERHEATED	● The unit is too hot. Let the unit cool down.

Before requesting help

General

PROBLEM	CAUSE & REMEDY
I cannot make and receive calls.	<ul style="list-style-type: none"> ● The power cord or telephone line cord is not connected. Check the connections (see page 10).
I cannot make calls.	<ul style="list-style-type: none"> ● The dialing mode setting is wrong. Check the setting and change it to TONE or PULSE (see page 10).
The unit does not work.	<ul style="list-style-type: none"> ● Disconnect the unit from the telephone line and connect to a known working phone. If the working phone operates properly, call your service center to have the unit repaired. If the working phone does not operate properly, consult with your telephone company.
The unit does not ring.	<ul style="list-style-type: none"> ● The ringer volume is set to OFF. Adjust to a suitable level (see page 17).
The REDIAL/PAUSE button does not function properly.	<ul style="list-style-type: none"> ● If this button is pressed during dialing, a pause will be inserted. If this button is pressed immediately after a dial tone is obtained, the last number dialed will be redialed.
The receive mode does not function as explained on page 22.	<ul style="list-style-type: none"> ● A distinctive ringing pattern is set. Check it (see page 43).
During programming, I cannot enter the remote fax activation code, mailbox password or remote operation ID.	<ul style="list-style-type: none"> ● All or part of the number is the same as another code, password or ID. Change the number (see pages 41, 46 and 52).

Fax Transmission

PROBLEM	CAUSE & REMEDY
The other party complains that letters on their received document are distorted.	<ul style="list-style-type: none"> ● If your line has special telephone services such as call waiting, the service may have been activated during fax transmission. Connect the unit to a line that does not have such services. ● An extension telephone on the same line is off the hook. Hang up and try again.
The other party complains that dirty patterns or black lines appear on their received documents.	<ul style="list-style-type: none"> ● The glass or rollers are dirty. Clean them (see page 75).
The other party complains that they cannot send documents.	<ul style="list-style-type: none"> ● The junk mail prohibitor is set to ON. Program their facsimile number for automatic dialing (see page 33) or set the junk mail prohibitor to OFF (see page 42).
I cannot make an international fax call.	<ul style="list-style-type: none"> ● Use the overseas transmission mode (see page 60). ● Add two pauses at the end of the phone number (see page 37).

Before requesting help (cont.)

Fax Reception

PROBLEM	CAUSE & REMEDY
I cannot receive documents automatically.	<ul style="list-style-type: none">● The receive mode is set to the TEL mode. Set to the ANS/FAX, TEL/FAX or FAX mode.● The time to answer the call may be too long. Decrease the number of rings (see pages 57, 58 and 59).● The greeting message is too long. Shorten the message (see page 44).● The junk mail prohibitor is set to ON (see page 42).
The recording image is faint.	<ul style="list-style-type: none">● The sender transmitted a faint document. Ask the sender to transmit a clearer copy of the document.
The received document is blank.	<ul style="list-style-type: none">● The recording paper roll is installed incorrectly. Make sure that the shiny side of the paper is facing down and re-install the paper (see page 9).

Answering Device

PROBLEM	CAUSE & REMEDY
No voice messages have been recorded in the ANS/FAX mode.	<ul style="list-style-type: none">● The memory is full. Erase some or all of the messages (see pages 26 and 48).
I cannot retrieve recorded messages from a remote phone.	<ul style="list-style-type: none">● Make sure that you use the remote operation ID correctly (see page 52).
Messages in the mailbox do not play back.	<ul style="list-style-type: none">● The mailbox password is wrong. Enter the correct password (see page 46).

Copying

PROBLEM	CAUSE & REMEDY
A dirty pattern or a black line appears on the copied documents.	<ul style="list-style-type: none">● The glass or rollers are dirty. Clean them (see page 75).
The copied document is blank.	<ul style="list-style-type: none">● The recording paper roll is installed incorrectly. Make sure that the shiny side of the paper is facing down and re-install the paper (see page 9).

If a power failure occurs....

- The unit does not function.
- The memory contents will not be erased.
- If the programmed start time has passed during a power failure, delayed transmission will be attempted after power is restored.

Clearing a recording paper jam

If the unit does not eject any recording paper during reception or copying, the recording paper has jammed. Remove the jammed paper as shown below.

- 1 Open the back cover by lifting up the tabs located on both sides, and press the green lever to release the paper cutter.

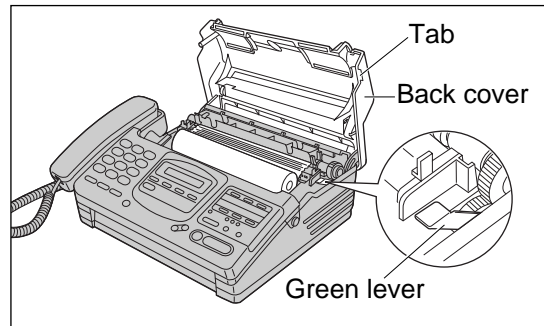

- 2 Pull up the corners of the transparent guide and remove the jammed piece of paper.
 - If the transparent guide is not pulled up, press the green lever again.

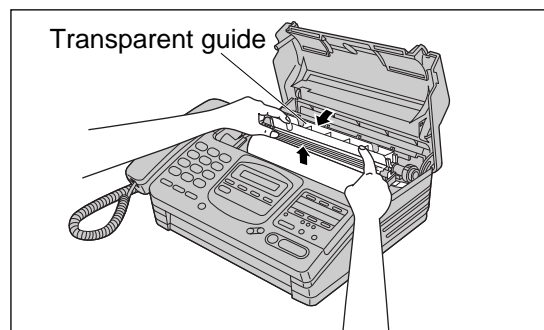

- 3 Replace the transparent guide and recording paper roll in the proper direction, and insert the leading edge of the paper between the recording paper roller and the silver plate.
 - Make sure that there is no slack in the paper roll.

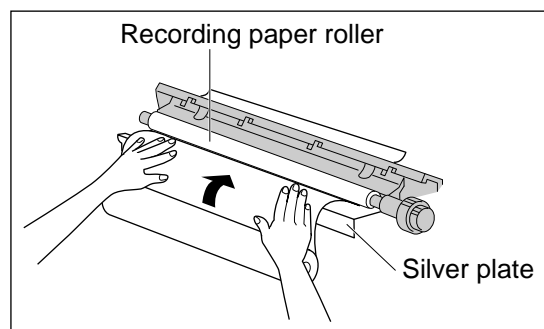

- 4 Close the back cover by gently pressing down on both corners of the cover.
 - A message is printed.
 - When the recording paper is set to the wrong side, a message is not printed. Install the recording paper correctly.

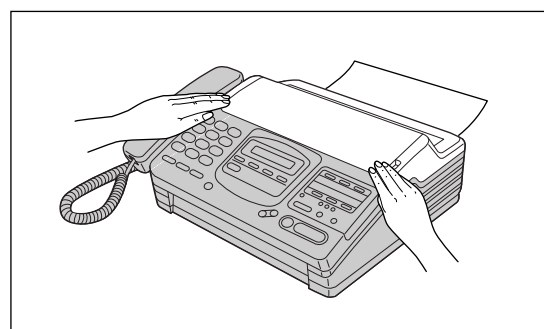

Clearing a document jam

If the unit does not release the original document during feeding, remove it as shown below.

- 1** Open the front cover by pressing the front cover open button.
- 2** Remove the jammed document carefully.
- 3** Close the front cover by gently pressing down on both corners of the cover.

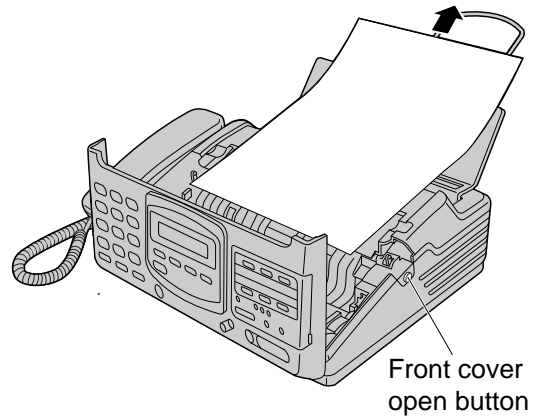

Adjusting the feeder pressure

When no feeding or multiple feeding occurs frequently, adjust the feeder pressure.

- 1** Open the front cover by pressing the front cover open button.
- 2** Shift the position of the lever by using an instrument with a pointed end, like a clip or ball-point pen.

Position A: When documents do not feed
Position B: Standard position (pre-selected)
Position C: When documents multiple feed
- 3** Close the front cover by gently pressing down on both corners.

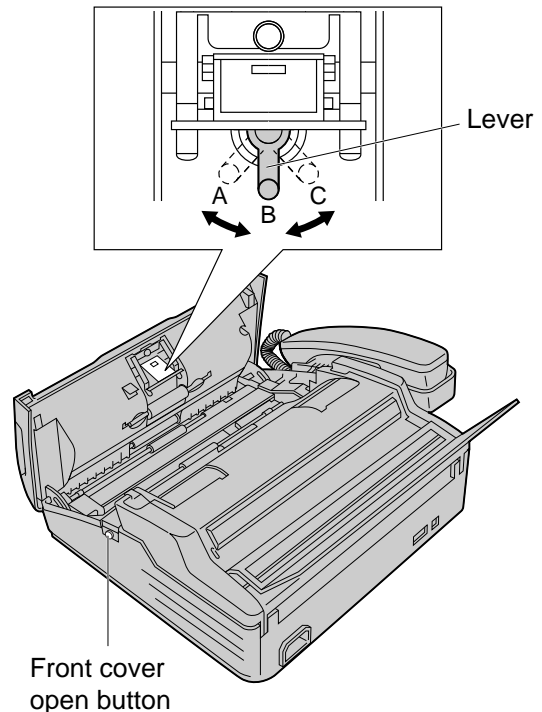

Routine care

Removing the handset cradle

To save space or to use the unit mainly for faxes, you may remove the handset cradle.

- 1 Set the handset switch to "NO HANDSET" (see page 65).
- 2 Pull the hooks to the right in the order as shown, while lifting up the handset cradle.
- 3 Disconnect and connect the power cord.

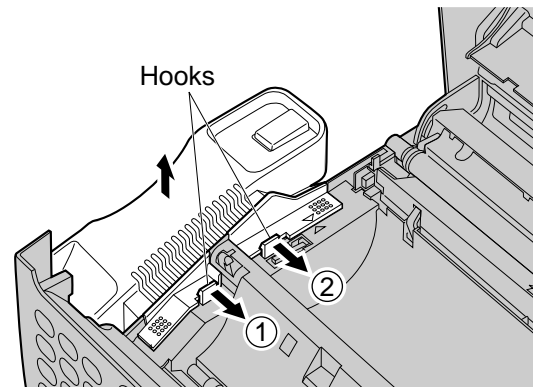

Caution:

- If the handset and handset cradle have been removed when you connect the power cord, an alarm will sound and the following message will be displayed.

CHECK CRADLE

Set the handset switch to "NO HANDSET" (see page 65).

Cleaning the inside of the unit

If misfeeding occurs frequently or dirty patterns or black bands appear on a copied or transmitted document, clean the document feeder rollers, sub roller, rubber flap, white plate and glass.

- 1 Disconnect the power cord and the telephone line cord.
- 2 Open the front cover by pressing the front cover open button.
- 3 Clean the document feeder rollers and sub roller with a cloth moistened with isopropyl rubbing alcohol, and let dry thoroughly.
- 4 Clean the rubber flap with a cotton swab moistened with isopropyl rubbing alcohol, and let dry thoroughly.
- 5 Clean the white plate and glass with a soft dry cloth.
- 6 Close the front cover by gently pressing down on both corners of the cover.
- 7 Connect the power cord and the telephone line cord.

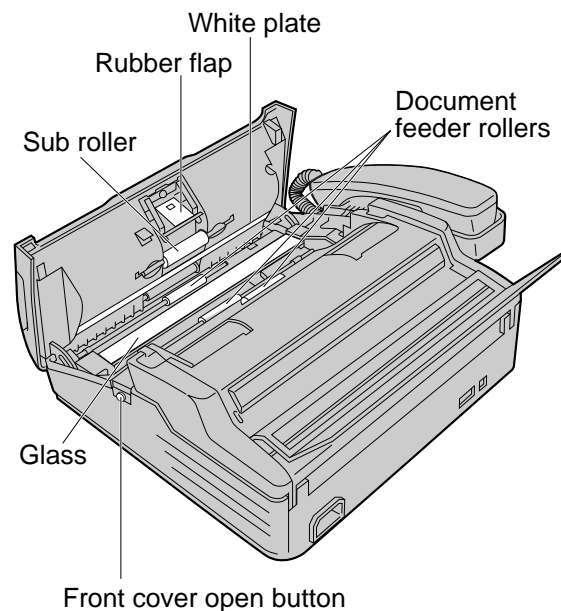

Caution:

- Do not use paper products (such as paper towels or tissues) to clean the inside of the unit.

General information

FCC information

If required by the telephone company, inform them of the following.

- FCC Registration No.:
(found on the bottom of the unit)
- Ringer Equivalence No.:
(found on the bottom of the unit)
- The particular telephone line to which the equipment is connected.

This unit must not be connected to a coin operated line. If you are on a party line, check with your local telephone company.

Ringer Equivalence Number (REN):

This REN is useful in determining the quantity of devices you may connect to your telephone line and still have all of those devices ring when your telephone number is called. In most but not all areas, the sum of the REN's of all devices connected to one line should not exceed five (5.0). To be certain of the number of devices you may connect to your line, as determined by the REN, you should contact your local telephone company to determine the maximum REN for your calling area.

In the event that terminal equipment causes harm to the telephone network, the telephone company should notify the customer, if possible, that service may be stopped. However, where prior notice is impractical, the company may temporarily cease service providing that they:

- a) Promptly notify the customer.
- b) Give the customer an opportunity to correct the problem with their equipment.
- c) Inform the customer of the right to bring a complaint to the Federal Communication Commission pursuant to procedures set out in FCC Rules and Regulations Subpart E of Part 68.

The Telephone Company may make changes in its communications facilities, equipment operations, or procedures where such action is reasonably required in the operation of its business and is not inconsistent with the rules and regulations in FCC Part 68. If such changes can be reasonably expected to render any customer terminal equipment incompatible with telephone company communications facilities, or require modification or

alteration of such terminal equipment, or otherwise materially affect its use or performance, the customer shall be given adequate notice in writing, to allow the customer an opportunity to maintain uninterrupted service.

CAUTION:

Any changes or modifications not expressly approved by the party responsible for compliance could void the user's authority to operate this device.

When programming emergency numbers and/or making test calls to emergency numbers:

1. Remain on the line and briefly explain to the dispatcher the reason for the call before hanging up.
2. Perform such activities in the off-peak hours; such as early morning or late evenings.

This telephone provides magnetic coupling to hearing aids.

NOTE:

This equipment has been tested and found to comply with the limits for a Class B digital device, pursuant to Part 15 of the FCC Rules. These limits are designed to provide reasonable protection against harmful interference in a residential installation. This equipment generates, uses, and can radiate radio frequency energy and, if not installed and used in accordance with the instructions, may cause harmful interference to radio communications. However, there is no guarantee that interference will not occur in a particular installation. If this equipment does cause harmful interference to radio or television reception, which can be determined by turning the equipment off and on, the user is encouraged to try to correct the interference by one or more of the following measures:

- Reorient or relocate the receiving antenna.
- Increase the separation between the equipment and receiver.
- Connect the equipment into an outlet on a circuit different from that to which the receiver is connected.
- Consult the dealer or an experienced radio/TV technician for help.

**Panasonic Consumer Electronics Company,
Division of Matsushita Electric Corporation of
America**
One Panasonic Way, Secaucus,
New Jersey 07094

**Panasonic Sales Company
Division of Matsushita Electric of
Puerto Rico, Inc.**
Ave. 65 de Infantería, Km. 9.5, San Gabriel
Industrial Park, Carolina, Puerto Rico 00985

PANASONIC Facsimile Products Limited Warranty

Panasonic Consumer Electronics Company or Panasonic Sales Company (collectively referred to as "the warrantor"), will repair this product with new or refurbished parts, free of charge, in the USA or Puerto Rico for one (1) year from the date of original purchase in the event of a defect in materials or workmanship.

Batteries (when applicable) — New rechargeable batteries in exchange for defective rechargeable batteries for ten (10) days from the date of original purchase. Non-rechargeable batteries are not warranted.

Carry-in or mail-in service in the USA or Puerto Rico can be obtained during the warranty period by contacting a Panasonic Services Company (PASC) Factory Servicenter listed in the Servicenter Directory. Or call, toll free, 1-800-HELP FAX (1-800-435-7329) to locate a PASC Factory Servicenter. Carry-in or mail-in service in Puerto Rico can be obtained during the warranty period by calling the local telephone number in the Servicenter Directory.

This warranty is extended only to the original purchaser. A purchase receipt or other proof of date of original purchase will be required before warranty service is rendered.

This warranty only covers failures due to defects in material or workmanship which occur during normal use and (when applicable) does not cover the print and ink cartridge, the toner cartridge and drum unit or the film cartridge. The warranty does not cover damages which occur in shipment, or failures which are caused by products not supplied by the warrantor, or failures which result from accident, misuse, abuse, neglect, mishandling, faulty installation, misapplication, set-up adjustments, improper operation or maintenance, alteration, modification, power line surge, improper voltage supply, lightning damage, signal reception problems, commercial use such as hotel, office, restaurant, or other business or rental use of the product, or service by anyone other than a PASC Factory Servicenter or a PASC authorized Servicenter, or damage that is attributable to acts of God.

LIMITS AND EXCLUSIONS

There are no express warranties except as listed above.

THE WARRANTOR SHALL NOT BE LIABLE FOR INCIDENTAL OR CONSEQUENTIAL DAMAGES RESULTING FROM THE USE OF THIS PRODUCT, OR ARISING OUT OF ANY BREACH OF THIS WARRANTY. ALL EXPRESS AND IMPLIED WARRANTIES, INCLUDING THE WARRANTIES OF MERCHANTABILITY, ARE LIMITED TO THE APPLICABLE WARRANTY PERIOD SET FORTH ABOVE.

Some states do not allow the exclusion or limitation of incidental or consequential damages, or limitations on how long an implied warranty lasts, so the above exclusions or limitations may not apply to you.

This warranty gives you specific legal rights and you may also have other rights which vary from state to state. If a problem with this product develops during or after the warranty period, you may contact your dealer or Servicenter. If the problem is not handled to your satisfaction, then write to the Customer Satisfaction Center at the company address indicated above.

Service center directory

OPERATION ASSISTANCE FAX ADVANTAGE PROGRAM

DIAL TOLL FREE: 1-800-HELP-FAX (1-800-435-7329) (9:00am–8:00pm Monday–Friday, EST)

PRODUCT INFORMATION LITERATURE REQUESTS DEALER LOCATIONS

Customer Satisfaction Center 2F-3, One Panasonic Way, Secaucus, NJ 07094 (Headquarters)
201-348-9090 (9:00am-8:00pm Monday-Friday, EST)

ACCESSORY PURCHASES

1-800-332-5368 (Consumer orders only)

Panasonic Services Company Accessory Order Office, 20421-84th Avenue South Kent, WA 98032
(6:00am–6:00pm Monday-Friday, 6:00am–10:30am Saturday, PST)
(Visa, Mastercard, Discover card, American Express, Check)

AUTHORIZED SERVICENTERS

CALIFORNIA

6550 Katella Avenue
Cypress, CA 90630
Phone (714) 373-7426
Fax (714) 894-8534

800 Dubuque Avenue
S. San Francisco,
CA 94080
Phone (415) 871-6373
Fax (415) 871-6840

20201 Sherman Way
Suite 102
Canoga Park, CA 91306
Phone (818) 709-1775
Fax (818) 709-2165

3878 Ruffin Road
Suite A
San Diego, CA 92123
Phone (619) 560-9200
Fax (619) 560-1831

COLORADO

1640 South Abilene Suite D
Aurora, CO 80012
Phone (303) 752-2024
Fax (303) 752-0610

FLORIDA

3700 North 29th Avenue
Suite 102
Hollywood, FL 33020
Phone (954) 925-2880
Fax (954) 925-5224

GEORGIA

8655 Roswell Road
Suite 100
Atlanta, GA 30350
Phone (770) 518-6301
Fax (770) 518-6306

HAWAII

99-859 Iwaiwa Street
Aiea, Hawaii 96701
Phone (808) 488-1996
Fax (808) 486-4369

ILLINOIS

*1703 North Randall Road
Elgin, IL 60123
"12:30 to 4:30, Mon-Fri"
Phone (847) 468-5464
Fax (847) 468-5465

9060 Golf Road
Niles, IL 60714
Phone (847) 608-1010
Fax (847) 299-1710

MARYLAND

62 Mountain Road
Glen Burnie
MD 21061
Phone (800) 973-4071
Fax (410) 760-3779

MASSACHUSETTS

60 Glacier Drive Suite G
Westwood, MA 02090
Phone (617) 329-4280
Fax (617) 329-0586

*pick-up/drop-off only

MICHIGAN

37048 Van Dyke Avenue
Sterling Heights, MI 48312
Phone (810) 939-2060
Fax (810) 939-2638

MINNESOTA

7850-12th Avenue South
Airport Business Center
Bloomington, MN 55425
Phone (612) 854-8624
Fax (612) 854-2089

OHIO

2236 Waycross Road
Cincinnati, OH 45240
Phone (513) 851-4180
Fax (513) 851-8443

PENNSYLVANIA

2221 Cabot Boulevard West
Suite B
Langhorne, PA 19047
Phone (215) 741-0661
Fax (215) 741-0521

Chartiers Valley
Shopping Center
1025 Washington Pike
Bridgeville, PA 15017
Phone (412) 257-4522
Fax (412) 257-4650

TENNESSEE

919-8th Avenue South
Nashville, TN 37203
Phone (615) 244-4434
Fax (615) 244-6713

TEXAS

7482 Harwin Drive
Houston, TX 77036
Phone (713) 781-1528
Fax (713) 781-0643

13615 Welch Road
Suite 101
Farmers Branch, TX 75244
Phone (972) 385-1975
Fax (972) 960-7626

WASHINGTON

20425-84th Avenue South
Kent, WA 98032
Phone (206) 872-7922
Fax (206) 872-0918

Service in Puerto Rico

**Matsushita Electric
of Puerto Rico, Inc.
Panasonic Sales Company/
Factory Servicenter**

Ave. 65 de Infantería, Km. 9.5
San Gabriel Industrial Park
Carolina, Puerto Rico 00985
Phone (787) 750-4300
Fax (787) 768-2910

REPAIR INQUIRIES

Regional Customer Care Department

EAST (PCE)

2221 Cabot Boulevard West
Suite A
Langhorne, PA 19047
Phone (215) 741-0676
Fax (215) 750-6492

Covers:

CT, DE, ME, MD, MA, NH, NJ,
NY, PA, RI, VT, VA, DC, WV

EAST (PCE)

1225 Northbrook Parkway
Suite 2-390
Suwanee, GA 30174
Phone (770) 338-6860
Fax (770) 338-6548

Covers:

AL, FL, GA, MS, NC, SC, TN

CENTRAL (PCC)

1707 North Randall Road
Elgin, IL 60123
Phone (847) 468-5530
Fax (847) 468-5528

Covers:

AR, IL, IN, IA, KS, KY, LA, MI,
MN, MO, NE, ND, OK, SD, TX,
WI, OH

WEST (PCW)

6550 Katella Avenue
Cypress, CA 90630
Phone (714) 373-7440
Fax (714) 373-7447

Covers:

AK, AZ, CA, CO, ID, MT, NV,
NM, OR, UT, WA, WY, HI

PARTS DISTRIBUTION LOCATIONS

To locate parts distributors in your area (within the USA)
DIAL TOLL FREE 1-800-545-2672 (24 hours a day, 7 days a week)

As of Apr. '97

User information

For product service

- Service centers are listed on page 78.
- Call toll free 1-800-545-2672 for the location of an authorized service center.

When you ship the product

- Carefully pack your unit, preferably in the original carton.
- Attach a letter, detailing the symptom or problem, to the outside of the carton.
- Send the unit to an authorized service center, prepaid and adequately insured.
- Do not send your unit to the Panasonic Consumer Electronics Company or to any executive or regional sales offices. These locations do not repair consumer products.

Specifications

- | | |
|------------------------------|---|
| 1. Applicable Lines: | Public Switched Telephone Network |
| 2. Document Size: | Max. 216 mm (8 ¹ / ₂ ") in width
Max. 600 mm (23 ⁵ / ₈ ") in length |
| 3. Effective Scanning Width: | 208 mm (8 ³ / ₁₆ ") |
| 4. Printing Paper Size: | 216 mm ~max. 50 m (8 ¹ / ₂ " ~164') roll |
| 5. Effective Printing Width: | 208 mm (8 ³ / ₁₆ ") |
| 6. Transmission Time *: | Approx. 15 s/page (Original mode)
Approx. 30 s/page (G3 Normal mode) |
| 7. Scanning Density: | Horizontal: 8 pels/mm (203 pels/inch)
Vertical: 3.85 lines/mm (98 lines/inch) —Standard mode
7.7 lines/mm (196 lines/inch) —Fine/Halftone mode
15.4 lines/mm (392 lines/inch) —Superfine mode |
| 8. Halftone Level: | 64-level |
| 9. Scanner Type: | CCD image sensor |
| 10. Printer Type: | Thermal printing |
| 11. Data Compression System: | Modified Huffman (MH), Modified READ (MR) |
| 12. Modem Speed: | 9600/7200/4800/2400 bps; Automatic Fallback |
| 13. Operating Environment: | 5–35 °C (41–95 °F), 45–85 % RH (Relative Humidity) |
| 14. Dimensions (H -W -D): | 118 ~351 ~265 mm (4 ² / ₃₂ " ~13 ¹³ / ₁₆ " ~10 ⁷ / ₁₆ ") |
| 15. Mass (Weight): | Approx. 3.7 kg (8.2 lb.) |
| 16. Power Consumption: | Standby: Approx. 3.5 W
Transmission: Approx. 16 W
Reception: Approx. 28 W
Copy: Approx. 40 W
Maximum: Approx. 120 W |
| 17. Power Supply: | 120 V AC, 60 Hz (This unit will not function at 50 Hz.) |
| 18. Memory Capacity: | Approx. 18 minutes of recording time including the greeting message when no fax documents are in memory.**
OR
Approx. 13 pages of document memory based on CCITT No.1 Test Chart in standard resolution when no voice messages have been recorded.*** |

* Transmission speed depends upon the contents of the pages, resolution, telephone line conditions and capability of the receiving unit.
The 15 second speed is based upon CCITT No.1 Test Chart.

** Recording time may be reduced by the caller party's background noise.

*** If both fax documents and voice messages are recorded in memory, the corresponding capacities above will be shortened.

CCITT No.1 Test Chart



Note:

- Any details given in these instructions are subject to change without notice.
- The pictures and illustrations in these instructions may vary slightly from the actual product.

Speed dialing list

Station No.	Name/Phone No.	Station No.	Name/Phone No.
00		25	
01		26	
02		27	
03		28	
04		29	
05		30	
06		31	
07		32	
08		33	
09		34	
10		35	
11		36	
12		37	
13		38	
14		39	
15		40	
16		41	
17		42	
18		43	
19		44	
20		45	
21		46	
22		47	
23		48	
24		49	

Speed dialing list

Station No.	Name/Phone No.	Station No.	Name/Phone No.
00		25	
01		26	
02		27	
03		28	
04		29	
05		30	
06		31	
07		32	
08		33	
09		34	
10		35	
11		36	
12		37	
13		38	
14		39	
15		40	
16		41	
17		42	
18		43	
19		44	
20		45	
21		46	
22		47	
23		48	
24		49	

Index

A	Advanced features56	L	Logo14
	Resetting.....65		Logo print position.....60
	ALL MSGS. PLAY BACK button26		LOWER key33, 34
	ANS/FAX mode.....22, 24	M	MAIL BOX button47
	ANS/FAX ring count.....57		Mailbox alert.....48
	AUTO RECEIVE button22, 24		Mailbox password46
	AUTO RECEIVE mode22, 24		MANUAL RECEIVE mode22, 31
	Automatic dialing.....33		MEMO/2WAY REC button28
B	Basic features56		Message alert61
C	Call counter26		Message transfer49
	Caller ID17		MUTE button.....16
	Caller list69	N	NEW MSGS. PLAY BACK button26
	Caller's recording time59	O	One-touch dialing.....33, 34
	CHECK button45		Overseas transmission mode60
	Cleaning.....75	P	Pager call49
	COPY button.....18		PAUSE button.....37
D	Date and time.....13		Polling38
	Delayed transmission.....39	Q	QUICK button.....27
	DELETE key14	R	REC button44
	Dialing mode10		Recording paper jam.....73
	DIGITAL SP-PHONE button16, 36		Recording time alert.....62
	DIRECTORY button.....34, 35		Recording time for ANS/FAX greeting message63
	Display contrast61		REDIAL button.....37
	Distinctive ring service43		Remote fax activation code.....41
	Document jam.....74		Remote operation ID.....52
	Documents the unit can feed20		REPEAT button.....27
E	Electronic telephone directory.....35		RESOLUTION button.....18
	ERASE button.....26, 45, 48		Ring pattern detection.....43
	Error message70	S	SECRET key.....33
F	Facsimile telephone number.....15		SELECT button44
	Fax auto redial34		Silent fax recognition ring count.....59
	FAX mode22, 29		SKIP button.....27
	Fax pager.....64		SLOW button27
	FAX ring count58		SPACE key14
	Fax voice guidance19, 23, 63		Speed dialing33, 34
	Feeder pressure.....74	T	TEL mode22
	FLASH button37		TEL/FAX mode22, 30
	Friendly reception23, 62		TEL/FAX ring count.....58
G	Greeting messages.....25, 44		Telephone number list66
H	Handset switch.....65		Toll saver57
	HELP button.....12		TONE button37
I	INSERT key14		Transmission report66, 67, 68
J	Journal auto print67	V	Voice contact36
	Journal report.....66, 68		Voice guide21
	Junk mail prohibitor.....42		Voice time/day stamp.....26
			VOLUME button.....16, 17, 21, 28

Panasonic FAX ADVANTAGE PROGRAM

*Free peace of mind,
direct from Panasonic*

NO EXTRA COST



- **1-year limited warranty¹ parts & labor**
- **Toll-free help line**
- **Free overnight replacement² and repair program**

The Panasonic Fax Advantage Consumer Service Program.

Panasonic knows that if your fax machine is not up and running, neither is your business. That's why we created the Panasonic Fax Advantage Program. Included at no extra cost with the purchase of a Panasonic Fax Machine, the Fax Advantage Program can provide a free replacement unit² overnight if your original unit is in need of repair.

Here's how it works:

1. If you have a problem with your fax while it is covered by the one-year limited warranty¹, call our toll-free help-line at 1-800-HELPFAX.
2. Talk to one of our technical experts to diagnose your problem over the phone.
3. If repairs are necessary and you are entitled to service under the terms and conditions of the limited warranty³, we will send a refurbished replacement unit to you overnight or second business day delivery, depending on the time of your call.

A second option available under our one-year limited warranty is to mail-in or carry-in your fax to one of our Regional Service centers, where the unit will be repaired and returned to you.

Instructions

If you choose to receive a replacement unit under the Fax Advantage Program, Panasonic will provide a replacement unit which will be completely refurbished, quality-tested by Panasonic technicians and individually hand-inspected before it is shipped to you. You will keep the replacement unit and send the original unit to us in the replacement unit's box. UPS will pick up the unit at no charge to you, should it be determined that you are entitled to warranty service. A proof-of-purchase must be included with the returned product. Any unit that is replaced by Panasonic and not shipped with proper proof-of-purchase by you will be subject to a minimum \$100.00 charge. The original unit must be properly packaged in the same manner as the replacement unit, utilizing

the packing materials provided. Damage due to improper or inadequate packing will be charged to you as an out-of-warranty cost.

If our 1-800-HELPFAX technicians determine that your unit may be an "out-of-box failure"⁴, we will attempt to provide you with a factory-new replacement unit⁵. You must ship a copy of your receipt with your original unit to verify that you purchased the unit within 10 days prior to your 1-800-HELPFAX call.

Requirements

You must give our technicians a valid credit card number (Discover, VISA, Master Card, or American Express/Optima). Product that is not returned to Panasonic by 10 business days after shipment of the replacement product will be charged to your credit card account at Panasonic's Suggested Retail Price (see dealer for details). If your original unit is not eligible for warranty service, your card will be charged for the non-warranty repair of the unit at Panasonic's current rate for parts and labor and for any shipping charges associated with this program. If you do not wish to pay out-of-warranty repair costs, you will be responsible for returning the replacement unit to Panasonic and for paying all shipping charges associated with this program including the overnight delivery of the replacement product to you, shipment of the problem unit to Panasonic, shipment of the replacement unit back to Panasonic and the return of your original unit back to you. Credit status will be verified prior to sending the replacement product.

1. See dealer for limited warranty details.
2. Replacement unit is refurbished.
3. Replacement program excludes Puerto Rico and is subject to termination at any time without advance notice.
4. "Out-of-box failure" is an inoperable unit that was purchased no more than 10 days prior to your 1-800-HELPFAX call, and would otherwise qualify for warranty service under the terms and conditions of the limited warranty.
5. Panasonic reserves the right to send a refurbished unit.

Panasonic Consumer Electronics Company, Division of Matsushita Electric Corporation of America
One Panasonic Way, Secaucus,
New Jersey 07094

Panasonic Sales Company, Division of Matsushita Electric of Puerto Rico, Inc. ("PSC")
Ave. 65 de Infantería, Km. 9.5
San Gabriel Industrial Park, Carolina,
Puerto Rico 00985

Free Manuals Download Website

<http://myh66.com>

<http://usermanuals.us>

<http://www.somanuals.com>

<http://www.4manuals.cc>

<http://www.manual-lib.com>

<http://www.404manual.com>

<http://www.luxmanual.com>

<http://aubethermostatmanual.com>

Golf course search by state

<http://golfingnear.com>

Email search by domain

<http://emailbydomain.com>

Auto manuals search

<http://auto.somanuals.com>

TV manuals search

<http://tv.somanuals.com>