

Panasonic

Digital Proprietary Telephones *Quick Reference Guide*

Model **KX-T7625E/KX-T7630E**
KX-T7633E/KX-T7636E

Important Information

When using the KX-T7600 series, keep the following conditions in mind.

- If there is any problem, unplug the extension line and connect a known working phone. If the known working phone operates properly, have the defective phone repaired by a specified Panasonic Factory Service Centre. If the known working phone does not operate properly, check the KX-TDA Series Business Telephone Systems and the internal extension wiring.
- Keep the unit away from heating appliances and electrical noise generating devices such as fluorescent lamps, motors and televisions. These noise sources can interfere with the performance of the unit.
- This unit should be kept free of dust, moisture, high temperature (more than 40 °C) and vibration, and should not be exposed to direct sunlight.
- Do not use benzine, thinner, or the like, or any abrasive powder to clean the cabinet. Wipe it with a soft cloth.
- Do not use any handset other than a Panasonic handset.
- Do not disassemble this product. Dangerous electrical shock could result. The unit must only be disassembled and repaired by qualified service technicians.
- When a failure occurs which exposes any internal parts, disconnect the telephone line cord immediately and return this unit to the service centre.
- Never attempt to insert wires, pins, etc, into the vents or other holes of this unit.
- This unit is designed to be installed under controlled conditions of ambient temperature and a relative humidity.
- Avoid installing the unit in damp or humid environments, such as bathrooms or swimming pools.
- 999 or 112 can be dialled on the product after accessing the CO line for the purpose of making outgoing calls to the BT emergency (999) and (112) services.

WARNING:

TO PREVENT FIRE OR SHOCK HAZARD, DO NOT EXPOSE THIS PRODUCT TO RAIN OR ANY TYPE OF MOISTURE.
THE HANDSET EARPIECE IS MAGNETISED AND MAY RETAIN SMALL FERROUS OBJECTS.

Note: In this manual, the suffix of each model number is omitted.

“Installing the KX-T7601/KX-T7603” is shown on page 9.

Features List

Outside (CO) Line button
 Off-hook
 On-hook
 Feature number
 Talk
 Incoming Call Distribution Group button
 Directed Station Selection button
 C. Tone Confirmation Tone
 D. Tone Dial Tone
 R.B. Tone Ringback Tone





Desired Feature	Operation
Making Calls	
Calling	<p>To an extension ► ► </p> <p>To an outside party ► / ► ► </p>
Redial	► ►
Quick Dialling	► ►
One-touch Dialling	<p>To store OR ► ► ► ► OR OR </p> <p>To dial ► ► </p>
Operator Call	► ►
Personal Speed Dialling	<p>To store ► ► ► ► ► </p> <p>To dial ► ► ► ► </p>
System Speed Dialling	To dial ► ► ►
Doorphone Call	► ► ►
Automatic Callback Busy	<p>To set <i>While hearing a busy tone</i> </p> <p>To cancel ► </p> <p>To answer (if set after dialling) <i>While hearing a callback ringing</i> ► </p> <p>To answer (if set when seizing an outside line) <i>While hearing a callback ringing</i> ► ► </p>
During a Conversation	
Call Hold	<p>To Hold </p> <p>To retrieve a call at the holding extension ► / / ► </p> <p>To retrieve an outside call from another extension ► / ► </p>
Call Transfer	<p>TRANSFER To an extension</p> <p> ► To an outside party</p> <p>► ► </p>

Features List

Desired Feature	Operation
Useful Features	
Off-Hook Monitor	<p>To set/cancel <i>During a conversation using the handset</i></p> <p>SP-PHONE <input type="checkbox"/></p>
Call Park	<p>To set <i>During a conversation</i></p> <p>TRANSFER <input type="checkbox"/> → * 5 2 → parking zone no. (2 digits) Specified <input type="checkbox"/> * Auto C. Tone </p> <hr style="border-top: 1px dashed black;"/> <p>To retrieve</p> <p> → * 5 2 → stored parking zone no. (2 digits) → </p>
Multiple party conversation	<p>To add other parties during a conversation</p> <p>CONF → desired phone no. → Talk to the new party.</p> <p>To leave a conference</p> <p>CONF → C. Tone Talk with multiple party.</p>
Call Pickup	<p> → * 4 1 → extension no. Directed C. Tone </p> <p>* 4 0 → pickup group no. (2 digits) Group </p> <p style="text-align: center; font-size: small;">(DSS)</p>
Sending a Call Waiting Tone	<p><i>While hearing a busy tone</i></p> <p><input type="checkbox"/> 1 → Wait for an answer. → </p>
Paging	<p>To page</p> <p> → * 3 3 → paging group no. (2 digits) C. Tone Announce. → Wait for an answer. → </p> <hr style="border-top: 1px dashed black;"/> <p>To answer</p> <p> → * 4 3 C. Tone </p> <hr style="border-top: 1px dashed black;"/> <p>To allow/deny a paged announcement</p> <p> → * 7 2 1 1 Deny C. Tone </p> <p>* 7 2 1 0 Allow</p>
Message Waiting	<p>Caller</p> <p><i>To leave a message waiting indication</i> <i>When the called extension is busy or does not answer</i></p> <p>MESSAGE C. Tone </p> <hr/> <p>Called extension</p> <p><i>To call back</i></p> <p> → MESSAGE → </p>
Log-in/Log-out	<p> → * 7 3 6 1 For Log-in → ICD Group extension no. Specified </p> <p>* 7 3 6 0 For Log-out → * All </p>

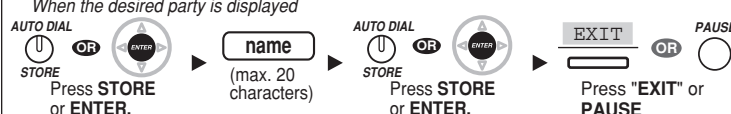
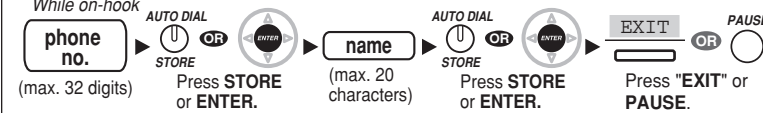
- * Consult your dealer for more details about the feature numbers.
- * You can change the flexible CO buttons to feature buttons.
- * For more details, refer to the Business Telephone System User Manual.
- * "Location of Controls" is shown on page 7.

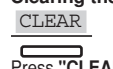
Using the Display Proprietary Telephone

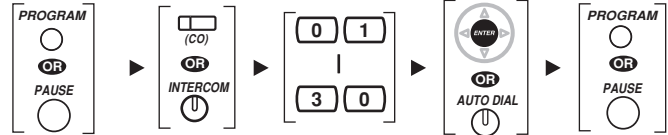
Desired Function	Operation
Accessing the System Features	<p><i>While on-hook</i></p>  <p>Press Right four times. Press ENTER. Press Up or Down until desired feature appears. Press ENTER.</p> <ul style="list-style-type: none"> You can access features as follows with the "Feature Access" menu: <ul style="list-style-type: none"> Automatic Callback Busy Cancel Door Open Group Call Pickup External Background Music Directed Call Pickup Paging Doorphone Call
Using the Log or Directories	<p>Storing the log information for Personal Speed Dialling Directory <i>When the desired party is displayed</i></p>  <p>Storing the names and numbers in the Personal Speed Dialling Directory <i>While on-hook</i></p>  <p>To call <i>While on-hook</i></p>  <p>Press Left or Right until desired log/directory appears. Press ENTER. Press Up or Down until desired party appears.</p> <ul style="list-style-type: none"> You can select and call with the directories as follows: <ul style="list-style-type: none"> Outgoing Call Log System Speed Dialling Directory Incoming Call Log Personal Speed Dialling Directory Extension Number Directory To cancel or exit the current display, press CANCEL. <p>Clearing the log information <i>When the desired party is displayed</i></p>  <p>Press "CLEAR".</p>
LCD Contrast	<p>KX-T7630/7633/7636 <i>While on-hook</i></p> 
Ring Tone	 <p>Press Twice. Press STORE.</p>

* "Location of Controls" is shown on page 7.



◆◆ Entering Characters

To toggle between Table 1 and Table 2, press the Soft button (S1) at any time while you are entering characters.

Table 1 (Standard mode)

Times Buttons	1	2	3	4	5	6	7	8	9
1	!	?	"	1					
2	A	B	C	a	b	c	2		
3	D	E	F	d	e	f	3		
4	G	H	I	g	h	i	4		
5	J	K	L	j	k	l	5		
6	M	N	O	m	n	o	6		
7	P	Q	R	S	p	q	r	s	7
8	T	U	V	t	u	v	8		
9	W	X	Y	Z	w	x	y	z	9
0	(space)	.	,	'	:	;	0		
*	/	+	-	=	<	>	*		
#	\$	%	&	@	()	€	£	#

Table 2 (Option mode)

Times Buttons	1	2	3	4	5	6	7	8	9	10	11	12	13	14	15
1	!	?	"	ä	ö	ü	1								
2	A	B	C	a	b	c	À	Á	Â	Ã	Ä	Å	Æ	Ç	2
3	D	E	F	d	e	f	Ð	È	É	Ê	Ë	3			
4	G	H	I	g	h	i	Ì	Í	Î	Ï	4				
5	J	K	L	j	k	l	5								
6	M	N	O	m	n	o	Ñ	Ò	Ó	Ô	Õ	Ö	Ø	Œ	6
7	P	Q	R	S	p	q	r	s	ß	7					
8	T	U	V	t	u	v	Û	Ú	Û	Ü	8				
9	W	X	Y	Z	w	x	y	z	Ý	9					
0	(space)	.	,	'	:	;	0								
*	/	+	-	=	<	>	*								
#	\$	%	&	@	()	€	£	#						

Settings on the Programming Mode

To enter the programme mode	To exit
PROGRAM <input type="radio"/> OR PAUSE <input type="radio"/>	PROGRAM <input type="radio"/> OR PAUSE <input type="radio"/>
Operation	
Alternate Receiving-Ring/Voice	<p>2 1 → ENTER OR AUTO DIAL STORE → [0 Ringing (Tone Call) / 1 Directly (Voice Call) / 2 Ring only (Voice Call Deny)] → ENTER OR AUTO DIAL STORE</p>
Call waiting for outside calls	<p>3 0 → ENTER OR AUTO DIAL STORE → [0 No (No tone) / 1 Yes (Tone)] → ENTER OR AUTO DIAL STORE</p>
Call Waiting Selection	<p>3 1 → ENTER OR AUTO DIAL STORE → [0 No Call / 1 Tone / 2 OHCA (Announce) / 3 Whisper OHCA] → ENTER OR AUTO DIAL STORE</p>
Call Waiting Tone Type Selection	<p>3 2 → ENTER OR AUTO DIAL STORE → [0 Tone 1 / 1 Tone 2] → ENTER OR AUTO DIAL STORE</p>
Headset Operation	<p>6 1 → ENTER OR AUTO DIAL STORE → [0 Headset off / 1 Headset on] → ENTER OR AUTO DIAL STORE</p>
Absent Message	<p>4 0 → ENTER OR AUTO DIAL STORE → [0 No-Off / Message no. (1-8) Yes-Shows the selected message. / 9 Yes-Shows your personal message.] → ENTER OR AUTO DIAL STORE</p>
Call Forwarding [FDW]/ Do Not Disturb [DND] (desired no. - max.32 digits)	<p>5 0 (for both calls) OR AUTO DIAL STORE → 5 1 (for outside calls) OR AUTO DIAL STORE → 5 2 (for intercom calls) OR AUTO DIAL STORE → [0 FWD/DND Off / 1 DND On / Forwarding a call / 2 All calls / 3 Busy / 4 No answer / 5 Busy/No answer] → desired no. → ENTER OR AUTO DIAL STORE</p>
Extension PIN [Personal Identification Number] (PIN - max.10 digits)	<p>To set an extension PIN: 9 0 → ENTER OR AUTO DIAL STORE → extension PIN → ENTER OR AUTO DIAL STORE → same PIN → ENTER OR AUTO DIAL STORE</p> <p>To change a stored extension PIN to new one: stored extension PIN → new PIN → ENTER OR AUTO DIAL STORE → same PIN → ENTER OR AUTO DIAL STORE</p>
Directory and Call Log Lock (PIN - max.10 digits)	<p>9 2 → ENTER OR AUTO DIAL STORE → Extension PIN → [0 To unlock / 1 To lock] → ENTER OR AUTO DIAL STORE</p>



- If nothing is entered within one minute in the programming mode, the mode returns to the normal status.
- To exit the mode at any time, lift the handset.
- For further information on "Setting on the Programming Mode", refer to the Business Telephone System User Manual.

Location of Controls

◆ KX-T7636

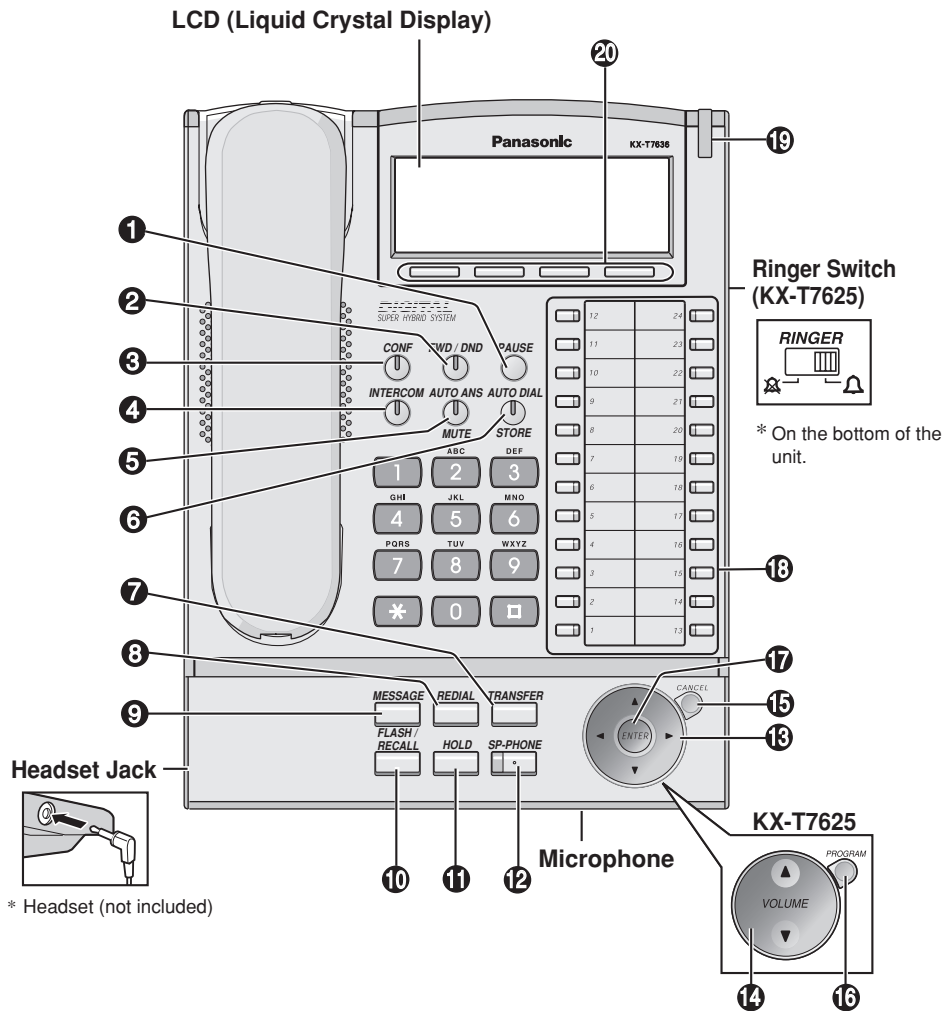

- ❶ **PAUSE:** Used to insert a pause when storing a telephone number. This button also functions as the PROGRAM button when there is no PROGRAM button on your telephone.
- ❷ **FWD/DND (Call Forwarding/Do Not Disturb):** Used to perform Call Forwarding or Do Not Disturb.
- ❸ **CONF (Conference):** Used to establish a multiple-party conversation.
- ❹ **INTERCOM:** Used to make or receive intercom calls.
- ❺ **AUTO ANSWER/MUTE:** Used to receive an incoming call in the hands-free mode or mute the microphone/handset during a conversation.

Location of Controls

- ⑥ **AUTO DIAL/STORE:** Used for System/Personal Speed Dialling or storing programme changes.
- ⑦ **TRANSFER:** Used to transfer a call to another party.
- ⑧ **REDIAL:** Used to redial the last dialled number.
- ⑨ **MESSAGE:** Used to leave a message waiting indication or call back the party who left the message waiting indication.
- ⑩ **FLASH/RECALL:** Used to disconnect the current call and make another call without hanging up.
- ⑪ **HOLD:** Used to place a call on hold.
- ⑫ **SP-PHONE (Speakerphone):** Used for the hands-free operation.
- ⑬ **Navigator Key (KX-7630/7633/7636):** Used to adjust the volume and the display contrast or select desired items. To adjust **Speaker/Handset/Headset/Ringer Volume**, press **Up** or **Down**.
- ⑭ **Volume Key (KX-T7625):** Used to adjust the volume. The Ringer Switch must be set to Δ . To adjust **Speaker/Handset/Headset/Ringer Volume**, press **Up** or **Down**.
- ⑮ **CANCEL (KX-T7630/7633/7636):** Used to cancel the selected item.
- ⑯ **PROGRAM (KX-T7625):** Used to enter and exit the personal programming mode.
- ⑰ **ENTER (KX-T7630/7633/7636):** Used to confirm the selected item.
- ⑱ **Flexible Outside (CO) Line Buttons:** Used to make or receive an outside call. Pressing this button seizes an idle outside line automatically. (Button assignment is required.) Also used as feature buttons. (Button assignment is required.)
- ⑲ **Message/Ringer Lamp:** When you receive an intercom call, the lamp flashes green, and on an outside call, the lamp flashes red. When someone has left you a message, the lamp stays on red.
- ⑳ **Soft Buttons (KX-T7630/7633/7636):** Used to select the item displayed on the bottom line on the display.

Tilt Angle Adjustment

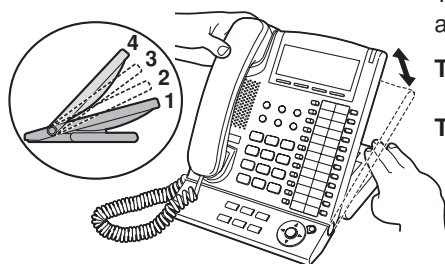

The tilt angle of the operation board can be adjusted to four steps-angles.

To lift: Lift up the operation board to the desired step-angle (1 → 2 → 3 → 4).

To set down: Lift up the operation board to the highest angle and then press down to step-angle 1. **Please do not get your fingers caught between the base unit and the operation board.**



- Pull down the handset hook until it locks to prevent the handset from slipping down from the operation board when at the step-angle 4.



Installing the KX-T7601/KX-T7603

To prevent damage to the telephone, be sure to unplug the extension line before you set up or remove the USB Module or the Add-on Key Module.

◆◆ KX-T7601 (For KX-T7633/7636) includes USB cable

The USB Module can be connected between the digital proprietary telephone and the personal computer through USB interface to implement personal CTI (Computer Telephony Integration).

- 1 Remove the connector cover using a screwdriver.

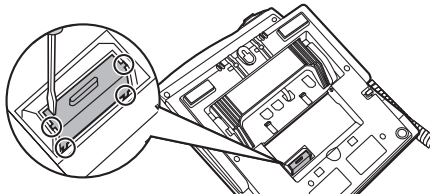

- 2 Insert the flat cable into the connector.

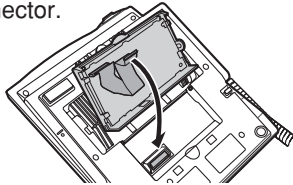

- 3 Couple both hinges and slide in the unit.

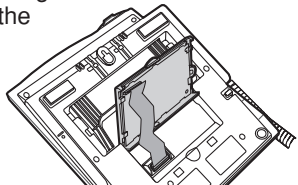

- 4 Push down the cover until it locks, and connect the USB cable to USB port.

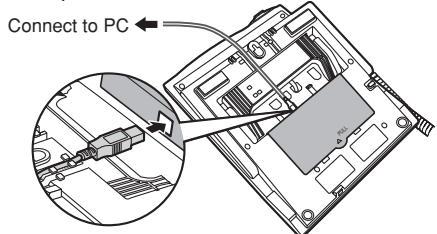

* Please use a USB cable shorter than 3 m.

◆◆ KX-T7603 (For KX-T7633/7636)

The Add-on Key Module has 12 CO buttons. These buttons are used to seize an outside line, make a call using One-touch Dialling, or access certain features.

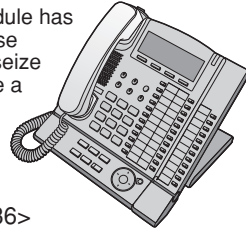

<with a KX-T7636>

- 1 Open the cover.

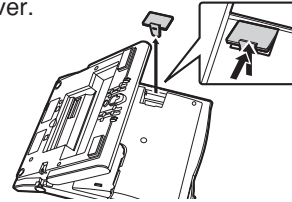

- 2 Attach the KX-T7603 to your telephone with screws.

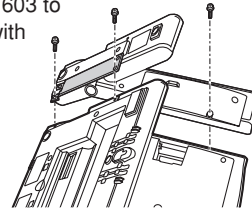

- 3 Insert the flat cable into the connector.

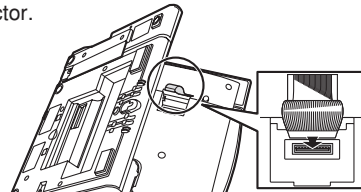

- 4 Close the cover.

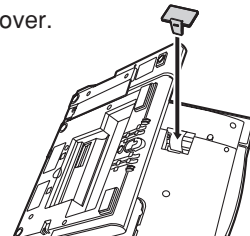

Wall Mounting

- 1** Fold up the operation board to step-angle 1.



- 2** Connect the telephone line cord, and then attach ① first and then ② of the wall mounting adaptor.

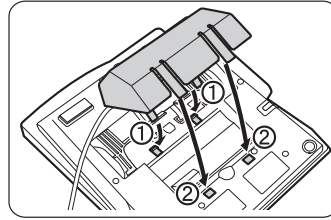

- 3** Mount the unit on the wall.

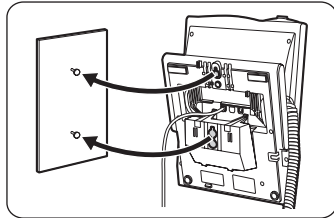

- 4** Pull down the handset hook until it locks, so the tab holds the handset.
To temporarily place the handset down during a conversation, hook it over the top edge of the phone as shown.

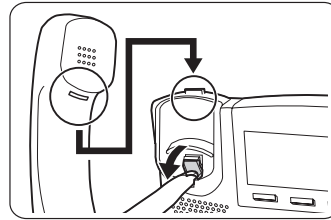

* The illustrations used in this page are a KX-T7636.

Connection

The telephone line cord (included)

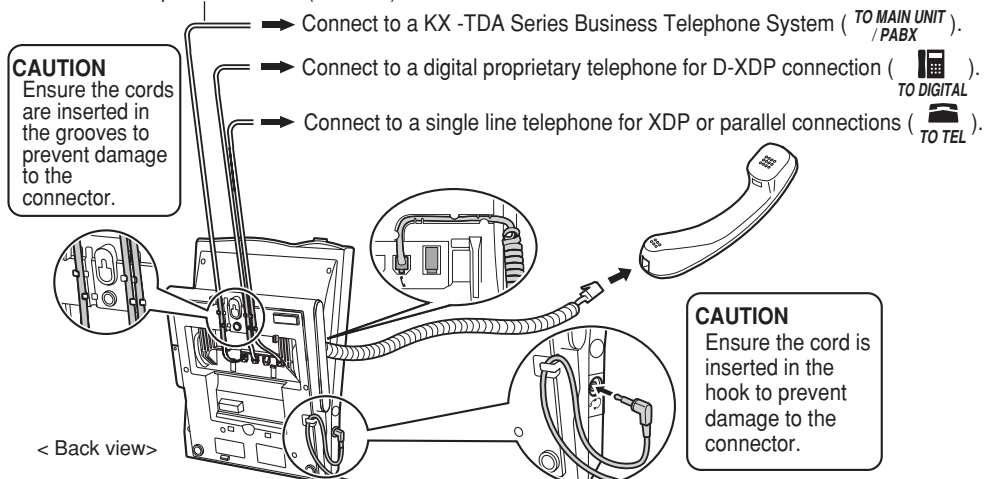

- Consult your dealer for more details about XDP and D-XDP.
- The availability of D-XDP function depends on the software version of the connected Business Telephone System.

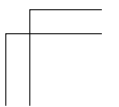
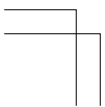
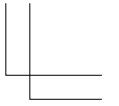
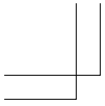

Other Information:

This unit is capable of being used in conjunction with hearing aids fitted with inductive coil pick-ups. The handset should be held as for normal conversation. For operation the hearing aid should be set to its "T" position or as directed in the operating instructions for the hearing aid.



Included Accessories:

Accessory	Qty	White Model	Black Model
Handset	1	PQJXF0502Z	PQJXF0522Z
Handset Cord	1	PSJA1084Z	PSJA1084X
Telephone Line Cord	1	PSJA1063Z	PSJA1063Z
Cabinet Stand	1	PSKL1014ZA1	PSKL1014ZA2



This product is intended to be connected to Panasonic KX-TDA series PABX only.

Hereby, Kyushu Matsushita Electric (U.K.) Limited declares that this product is in compliance with the essential requirements and other relevant provisions of Directive 1999/5/EC.

A copy of the manufacturer's declaration of conformity to the essential requirements of the R&TTE Directive is available at the following web address: <http://doc.panasonic-tc.de>

Copyright:

This manual is copyrighted by Kyushu Matsushita Electric (U.K.) Ltd. (KMEUK). Under the applicable copyright laws, this manual may not be reproduced in any form, in whole or in part, without the prior written consent of KMEUK.

© 2003 Kyushu Matsushita Electric (U.K.) Ltd. All Rights Reserved.

Panasonic Business Systems U.K.

Panasonic House, Willoughby Road, Bracknell, Berkshire RG12 8FP

Printed in the United Kingdom

PSQW1982YA KU1202KP0103KP1

Free Manuals Download Website

<http://myh66.com>

<http://usermanuals.us>

<http://www.somanuals.com>

<http://www.4manuals.cc>

<http://www.manual-lib.com>

<http://www.404manual.com>

<http://www.luxmanual.com>

<http://aubethermostatmanual.com>

Golf course search by state

<http://golfingnear.com>

Email search by domain

<http://emailbydomain.com>

Auto manuals search

<http://auto.somanuals.com>

TV manuals search

<http://tv.somanuals.com>