

Panasonic

Compact Plain Paper FAX

Model No.

KX-FP105BX

KX-FP105CX

Multi-Function Plain Paper FAX

Model No.

KX-FM131BX

KX-FM131CX



To get started,
please read the
Quick Start section
(p. 4 – 11).

Initial
Preparation

Telephone

Fax/Copy

Answering
Device

Help

General
Information

OPERATING INSTRUCTIONS

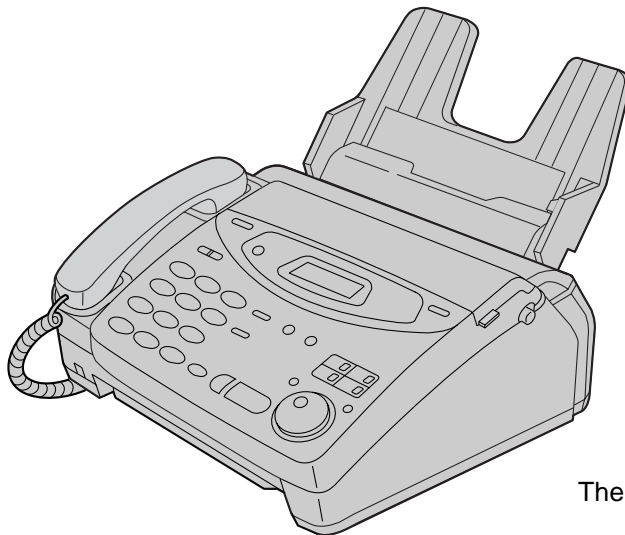

The pictured model is KX-FP105.

Please read these Operating Instructions
before using the unit and save for future
reference.

Thank you for purchasing a Panasonic facsimile.

Welcome to the world of Panasonic facsimiles.

This product combines various facsimile and telephone features to provide you with more efficient office or home use. By utilizing these convenient features, you can maximize the effectiveness of this unit.

For your future reference	
Date of purchase _____	Serial number _____ (found on the rear of the unit)
Dealer's name and address _____	
Dealer's telephone number _____	

Model difference

Model \ Features	Facsimile, Telephone and Copier	Answering Device	Scanner, PC-Fax and Printer
KX-FP105	Available	Not available	Not available
KX-FM131	Available	Available	Available

Caution:

- Note that the images of copied or received documents will remain on the used film. Use discretion when disposing of the used film cartridge.
- Do not rub or use an eraser on the printed side, as the print may smear.

Note:

- A suffix "BX" or "CX" in the model number is omitted in these instructions.
- Most figures shown in these operating instructions are based on a KX-FP105.

Copyright:

This manual is copyrighted by Kyushu Matsushita Electric Co., Ltd. (KME) and its licensee. Under the copyright laws, this manual may not be reproduced in any form, in whole or part, without the prior written consent of KME and its licensee.

© Kyushu Matsushita Electric Co., Ltd. 1999

Important safety instructions

When using this unit, basic safety precautions should always be followed to reduce the risk of fire, electric shock, or personal injury.

1. Read and understand all instructions.
2. Follow all warnings and instructions marked on this unit.
3. Unplug this unit from AC outlets before cleaning. Do not use liquid or aerosol cleaners. Use a damp cloth for cleaning.
4. Do not use this unit near water, for example near a bath tub, wash bowl, kitchen sink, or the like.
5. Place the unit securely on a stable surface. Serious damage and/or injury may result if the unit falls.
6. Do not cover slots and openings on the unit. They are provided for ventilation and protection against overheating. Never place the unit near radiators, or in a place where proper ventilation is not provided.
7. Use only the power source marked on the unit. If you are not sure of the type of power supplied to your home, consult your dealer or local power company.
8. For safety purposes this unit is equipped with a three prong grounded plug. If you do not have this type of outlet, please have one installed. Do not use any type of adaptor plug to defeat this safety feature.
9. Do not place objects on the power cord. Install the unit where no one can step or trip on the cord.
10. Do not overload wall outlets and extension cords. This can result in the risk of fire or electric shock.
11. Never push any objects through slots in this unit. This may result in the risk of fire or electric shock. Never spill any liquid on the unit.
12. To reduce the risk of electric shock, do not disassemble this unit. Take the unit to an authorized servicer when service is required. Opening or removing covers may expose you to dangerous voltages or other risks. Incorrect reassembly can cause electric shock when the unit is subsequently used.
13. Unplug this unit from the wall outlet and refer servicing to an authorized servicer when the following conditions occur:
 - A. When the power supply cord or plug is damaged or frayed.
 - B. If liquid has been spilled into the unit.
 - C. If the unit has been exposed to rain or water.
 - D. If the unit does not work normally by following the operating instructions. Adjust only controls covered by the operating instructions. Improper adjustment may require extensive work by an authorized servicer.
 - E. If the unit has been dropped or physically damaged.
 - F. If the unit exhibits a distinct change in performance.
14. During thunderstorms, avoid using telephones except cordless types. There may be a remote risk of an electric shock from lightning.
15. Do not use this unit to report a gas leak, when in the vicinity of the leak.

SAVE THESE INSTRUCTIONS

INSTALLATION

1. Never install telephone wiring during a lightning storm.
2. Never install telephone jacks in wet locations unless the jack is specifically designed for wet locations.
3. Never touch uninsulated telephone wires or terminals unless the telephone line has been disconnected at the network interface.
4. Use caution when installing or modifying telephone lines.

WARNING

- To prevent the risk of fire or electrical shock, do not expose this product to rain or any type of moisture.

OTHER INFORMATION

- Keep the unit away from electrical noise generating devices, such as fluorescent lamps and motors.
- The unit should be kept free from dust, high temperature and vibration.
- The unit should not be exposed to direct sunlight.
- Do not place heavy objects on top of this unit.
- Do not touch the plug with wet hands.

Quick Start

Installation

Before installation (p. 23)

A. Remove the shipping tape.

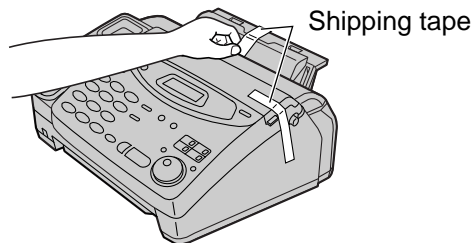

B. Open the cover, remove the leaflet under the film cartridge and close the cover.

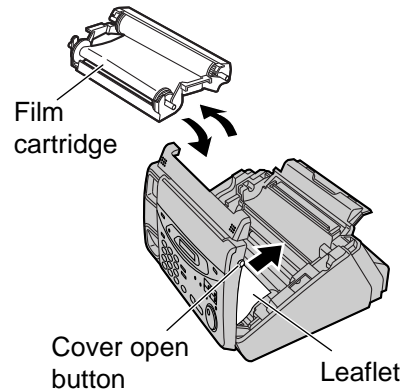

1 Paper tray (p. 24)

Insert the two tabs on the paper tray into the slots on the back of the unit.

2 A4 paper guides (p. 24)

Install the A4 paper guides.

3 Paper stacker (p. 25, 26)

Remove the shipping tape and install paper stacker.

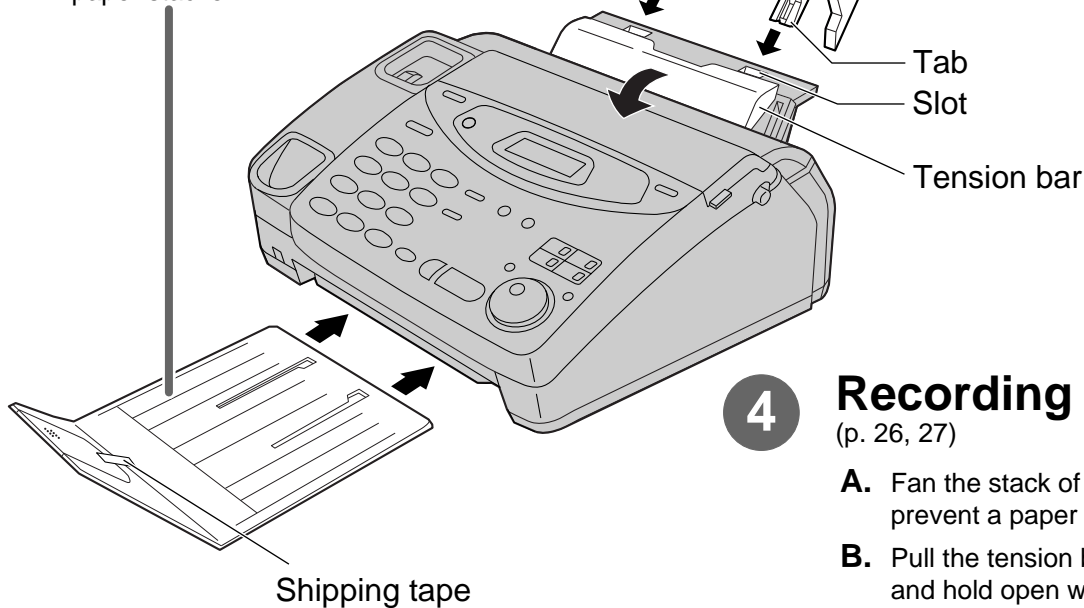

4 Recording paper (p. 26, 27)

A. Fan the stack of paper to prevent a paper jam.

B. Pull the tension bar forward and hold open while inserting the paper.

● For further details, see pages 23 to 27.

Connections

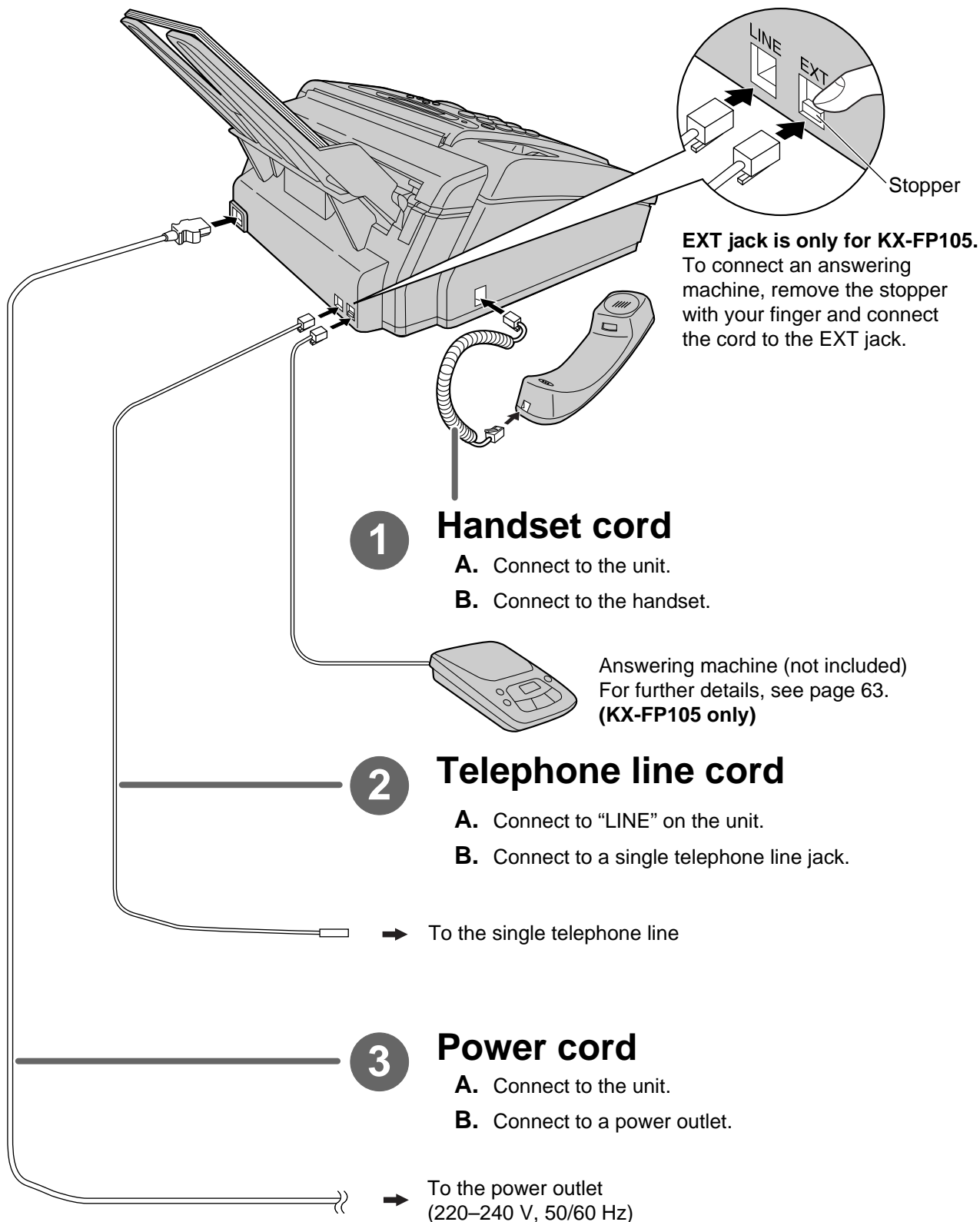

● For further details, see page 28.

Quick Start

Voice calls - making/answering

Voice calls - making

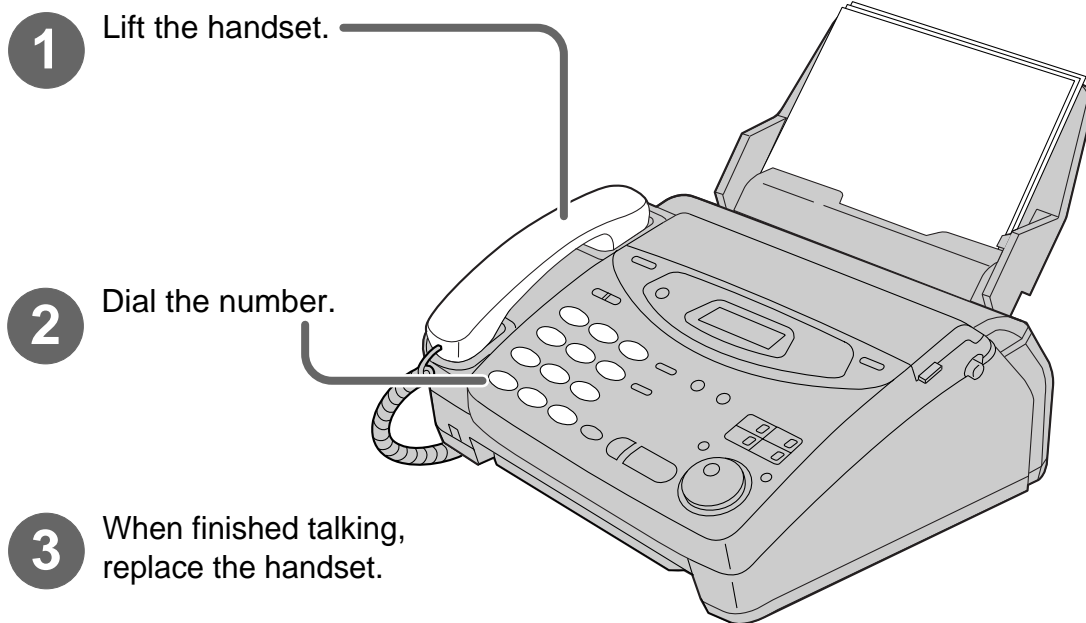

- For further details, see page 34.
- If you are having trouble, see page 112.

Voice calls - answering

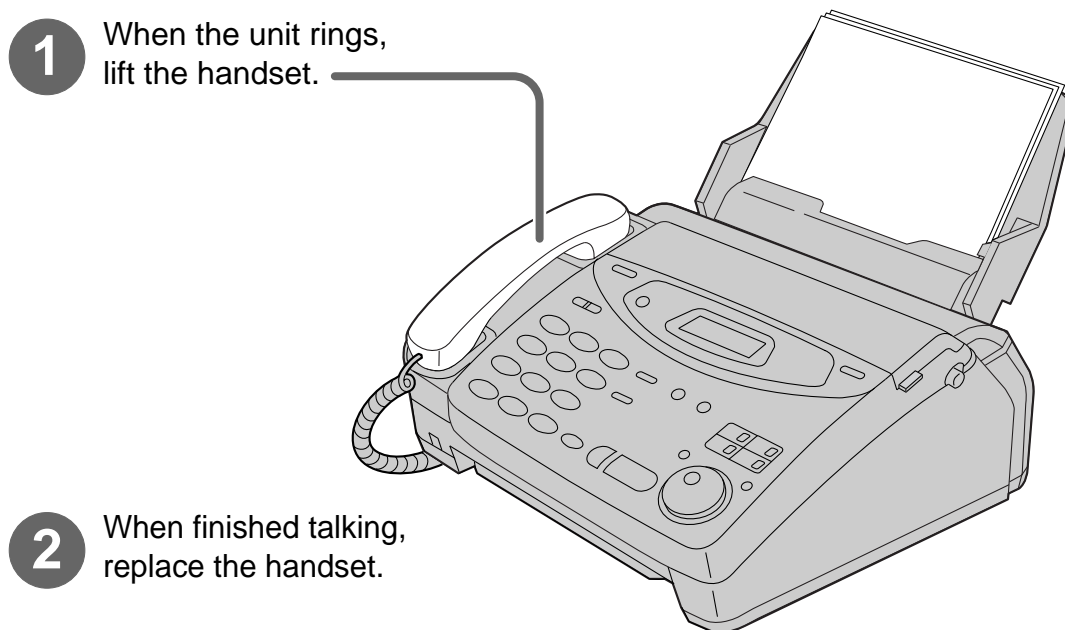

- For further details, see page 35.
- If you are having trouble, see page 112.

Faxes - sending/receiving

Faxes - sending

- 1 Open the document feeder tray.



- 2 Adjust the width of the document guides to the size of the document.

- 3 Insert the document until a single beep is heard and the unit grabs the document.

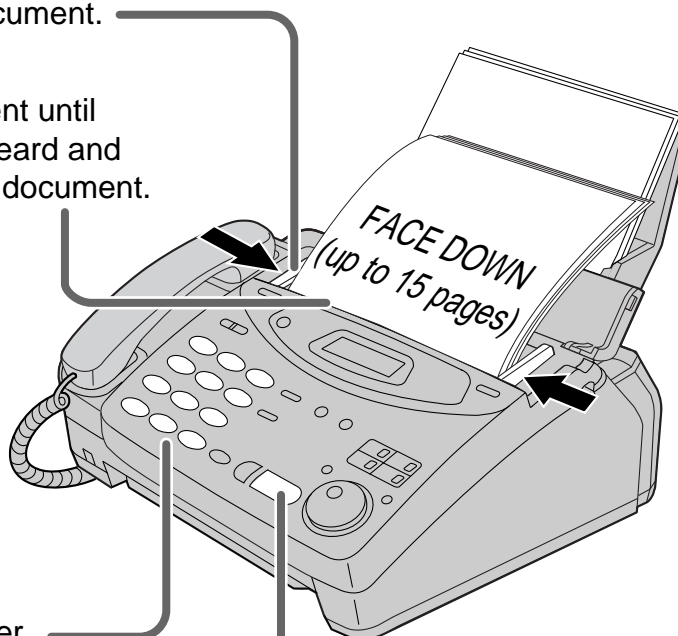

- 4 Dial the fax number.

- 5 Press **START/SET/COPY**.

- For further details, see page 44.
- If you are having trouble, see page 113.

Quick Start

Faxes - receiving

- 1 When the unit rings, lift the handset.

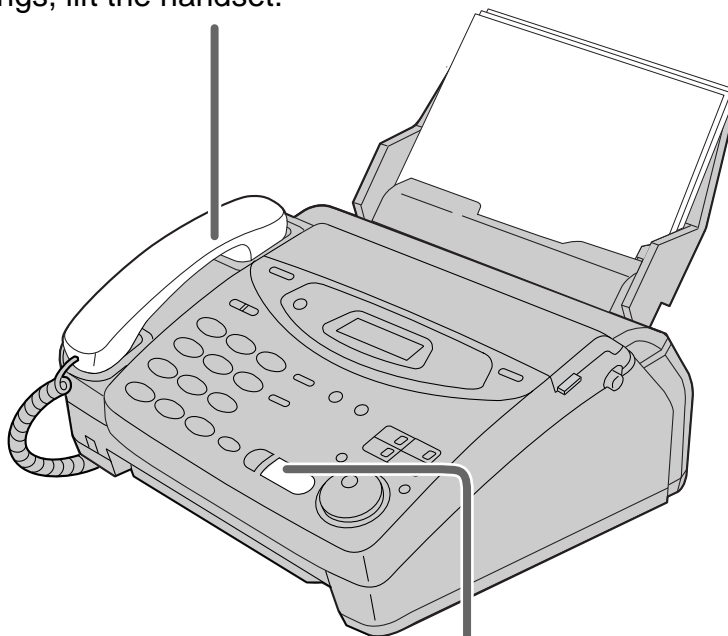

- 2 When:
 - document reception is required,
 - a fax calling tone (slow beep) is heard, or
 - no sound is heard,press **START/SET/COPY**.

- 3 Replace the handset.

- For further details, see page 62.
- **You can select the way to receive calls according to your needs.**
See pages 58 and 59 for KX-FP105.
See pages 60 and 61 for KX-FM131.
- If you are having trouble, see page 113.

Copying

- 1 Open the document feeder tray.



- 2 Adjust the width of the document guides to the size of the document.

- 3 Insert the document until a single beep is heard and the unit grabs the document.
 - Make sure the handset is on the cradle.

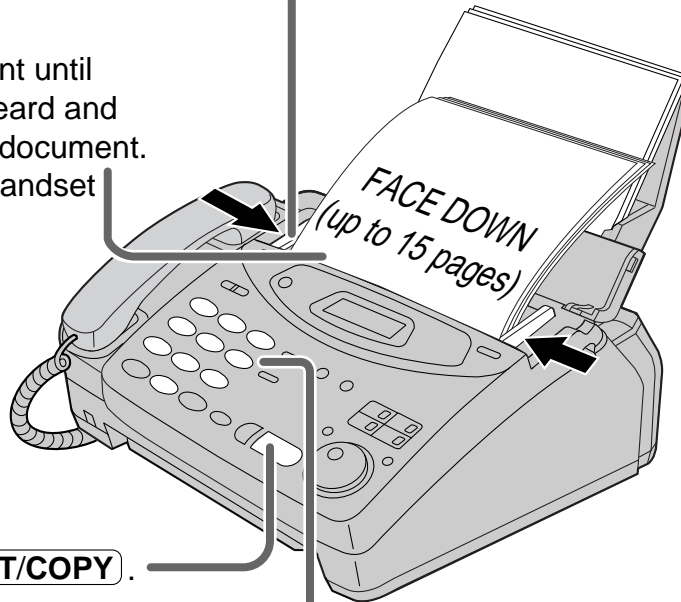

- 4 Press **START/SET/COPY**.

- 5 Enter the number of copies.

- 6 Press **START/SET/COPY**.

- For further details, see page 88.
- If you are having trouble, see page 114.

Quick Start

Operating the answering device (KX-FM131 only)

Setting the unit to receive voice and fax messages automatically

- 1** Press **AUTO ANSWER**.
 - The AUTO ANSWER light comes on.

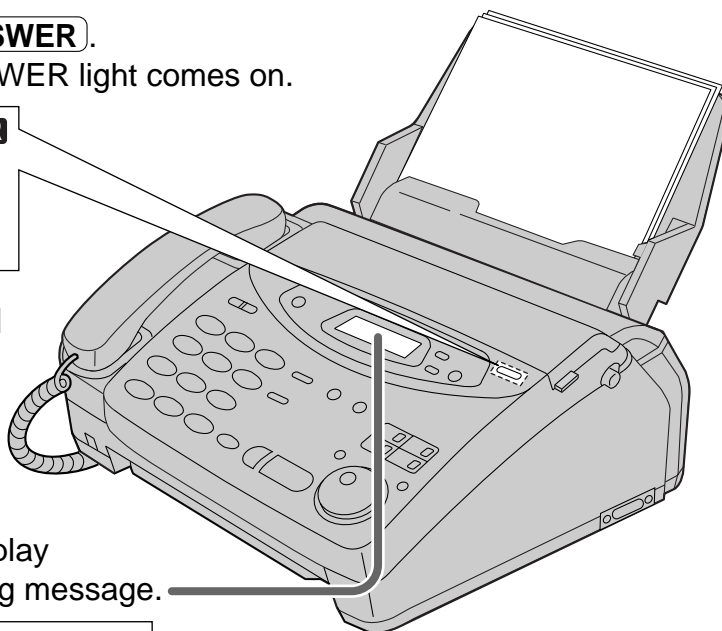
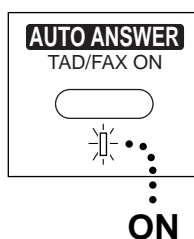

- 2** Make sure the display shows the following message.

TAD/FAX MODE

- If the display does not show this message, the setting needs to be changed to the TAD/FAX mode (p. 68).
-
- For further details, see page 90.

Listening to recorded messages

■ When the PLAY MESSAGES indicator flashes

Press **PLAY MESSAGES**.

- The new recorded messages will be played.

■ When the PLAY MESSAGES indicator lights

Press **PLAY MESSAGES**.

- All messages will be played.

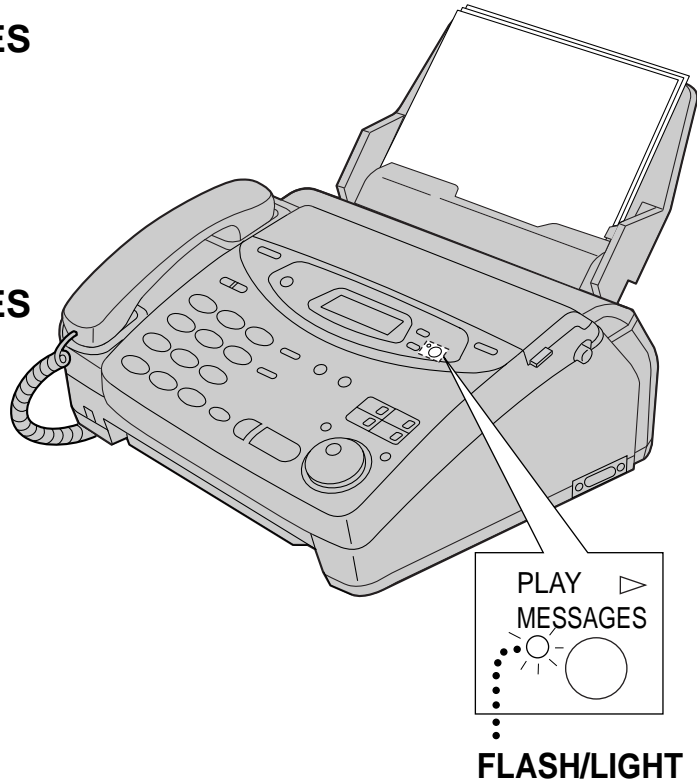

- For further details, see page 95.

Erasing recorded messages

■ Erasing a specific message

Press **ERASE** while listening to the message you want to erase.

■ Erasing all the messages

- 1** Press **ERASE** after listening to all of the messages.
- 2** Press **START/SET/COPY**.
 - To stop erasing, press **STOP**.
- 3** Press **START/SET/COPY** again.

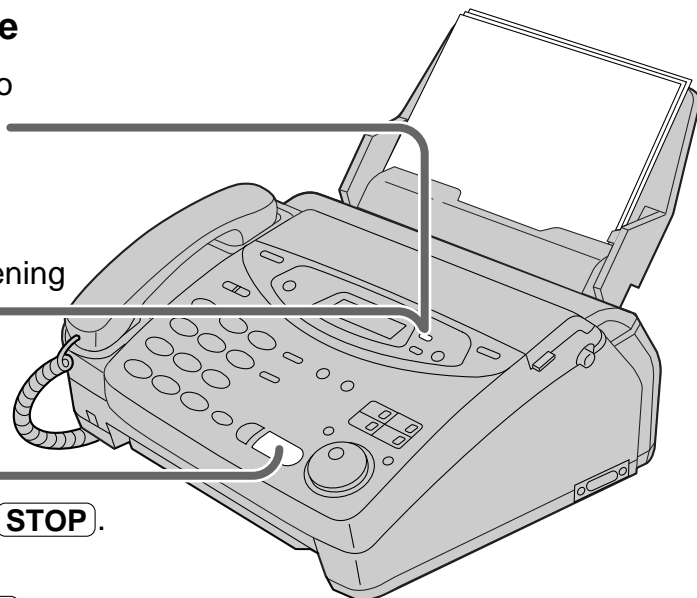

- For further details, see page 96.

Table of Contents

Initial Preparation	Accessories	Included accessories 15 Accessory order information 15
	Help Button	Help function 16
	Finding the Controls	Location 18 Overview 22
	Setup	Before installation 23 Paper tray 24 A4 paper guides 24 Paper stacker 25 Recording paper 26 Connections 28 Date and time, your logo and facsimile telephone number . . 29
	Volumes	Adjusting volumes 33
	Telephone	Making and Answering Calls
	One-Touch Dial	Storing names and telephone numbers in the One-Touch Dial 38 Making a voice call using the One-Touch Dial 39
	EASY DIAL	Storing names and telephone numbers in the EASY DIAL directory 40 Making a voice call using the EASY DIAL directory 42
	Voice Contact	Talking to the caller after fax transmission or reception . . 43
Fax/Copy	Sending Faxes	Sending a fax manually 44 Sending a fax using the One-Touch Dial 45 Sending a fax using the EASY DIAL directory 46 Sending a fax by following the voice guide (KX-FM131 only) 47 Documents you can send 48 Sending report for confirmation 49 Automatic journal report 50 Delayed transmission (sending a fax at a specified time) . . 51 From memory 52 Multiple stations 53 Overseas mode 56 Connecting tone 57

Fax/Copy

Receiving Faxes	Setting the unit to receive calls	58
	TEL mode (answering all calls manually)	62
	Using the unit with an answering machine (KX-FP105 only)	63
	FAX ONLY mode (all calls are received as faxes)	66
	Distinctive Ring service (ring pattern detection feature)	70
	TEL/FAX mode (receiving voice calls with rings and fax calls without rings when you are near the unit)	72
	Extension telephone	77
	Fax activation code	77
	Other size documents	78
	Silent detection (KX-FP105 only) (receiving faxes from older model fax machines)	79
	Using the unit and a computer on the same line (KX-FM131 only)	79
	Memory reception alert	80
	Friendly reception	81
	Auto disconnection (KX-FP105 only)	82
	Error correction mode setting	83
	Pager call	84
	Film detection	86
	Receive polling (retrieving a fax placed on another party's machine)	87
Copying	Making a copy	88

**Answering Device
(KX-FM131 only)**

Setup	TAD/FAX mode (using the built-in answering device and receiving voice and fax calls automatically)	90
Greeting	Pre-recorded greeting messages	91
	Recording your own greeting messages	92
	Checking your own recorded greeting messages	93
	Erasing your own recorded greeting messages	93
	Recording time for the TAD/FAX greeting message	94
Playing Messages	Listening to recorded messages	95
	Erasing recorded messages	96
	Functions while playing a message (repeating, skipping and stopping)	97
Recording	Memo message (leaving a message for others or yourself)	98
	Telephone conversation	98
Remote Operation	Operating from a remote location	99
	Setting the remote operation ID	100
	From a remote touch tone telephone	101
Options	Transferring recorded messages to another telephone	104
	Ring count in the TAD/FAX mode	107
	Incoming message recording time	108
	Message alert (beeps when a voice message is received)	108
	Recording time alert (beeps when memory is almost full)	109
	Incoming message monitor	109

Initial Preparation

Telephone

Fax/Copy

Answering Device

Help

General Information





Help

Error Messages	Reports 110 Display 110
Operations	When a function does not work, check here before requesting help 112 If a power failure occurs 116
Jams	Recording paper jams 117 Sending document jams 119 Sending document does not feed, or multi-feeds 120
Ink Film	How much film you have left 121 Replacing the film or film cartridge 122
Cleaning	Document feeder 125 Thermal head and black bar 126

General Information

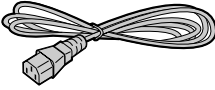
Print Reports	Printing the feature settings, telephone numbers, journal, printer test list and broadcast list 127
Fax Voice Guidance	Fax voice guidance (KX-FM131 only) 128
Display Contrast	Changing the display contrast 129
Original Mode	Setting the original mode 130
Reset	Resetting the advanced features 131
Specifications	Technical data about this product 132
Index	Index 133
Features Summary	Summary of user programmable features 135

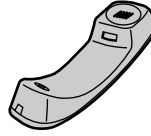
Included accessories

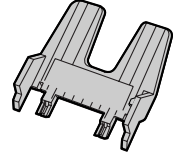
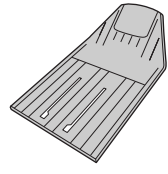
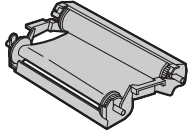
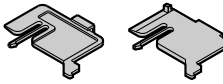
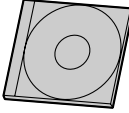
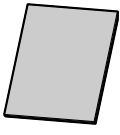
Power cord 1 	Telephone line cord 1 	Handset 1 	Handset cord . . . 1 	Paper tray 1 
Paper stacker . . . 1 	Film cartridge . . . 1  — The film cartridge is pre-installed.	A4 paper guides . . 2  (Left) (Right)	For KX-FM131 only	
			Panasonic PC software for KX-FM131 (CD-ROM) 1 	PANA LINK Software Guide . . 1 

- If any items are missing or damaged, check with the place of purchase.
- Save the original carton and packing materials for future shipping and transportation of the unit.

To use this unit with your PC (KX-FM131 only)

- A RS232C cable less than 3 meters long (DB9 Female/DB25 Male) is required to connect to a personal computer. Please purchase at any computer supply store.

Accessory order information

Model No.	Description	Specifications
KX-FA137A	Film cartridge	1 cartridge and 1 film [216 mm x 100 m (8½" x 328") roll] ● The film has already been installed in the cartridge. ● Replacement film (KX-FA136A) can be installed in the cartridge after initial usage.

Note:

- The film is not reusable. Do not rewind and use the film again.

Help Button

Help function

■ For KX-FP105

You can print a quick reference for assistance as follows.

1 Press **HELP**.
Display: **PRESS[▼▲]&[SET]**

2 Press **▼** or **▲** until the desired item is displayed. The following items are available.

1. How to program your unit

1.HOW TO SET UP

2. How to store names in the EASY DIAL directory and how to dial them

2.EASY DIAL

3. Help with problems receiving faxes

3.FAX RECEIVING

4. How to use the copier function

4.COPIER

5. List of available reports

5.REPORTS

3 Press **START/SET/COPY**.

PRINTING

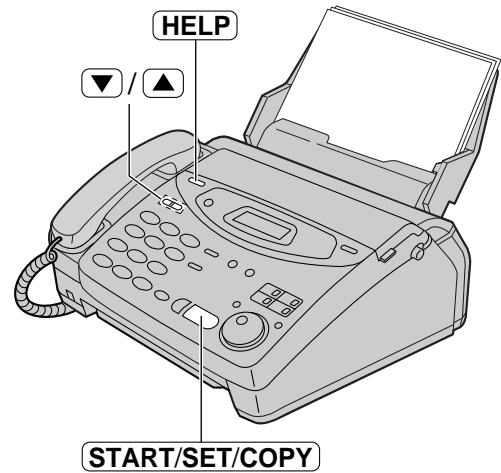

■ For KX-FM131

You can print a quick reference for assistance as follows.

1 Press **HELP**.
Display: **PRESS[▼▲]&[SET]**

2 Press **▼** or **▲** until the desired item is displayed. The following items are available.

1. How to send faxes with the voice guide

1.SEND GUIDE

2. How to program your unit

2.HOW TO SET UP

3. How to store names in the EASY DIAL directory and how to dial them

3.EASY DIAL

4. Help with problems operating answering device

4.TAD OPERATION

5. Help with problems receiving faxes

5.FAX RECEIVING

6. How to use the copier function

6.COPIER

7. List of available reports

7.REPORTS

3 Press **START/SET/COPY**.

PRINTING

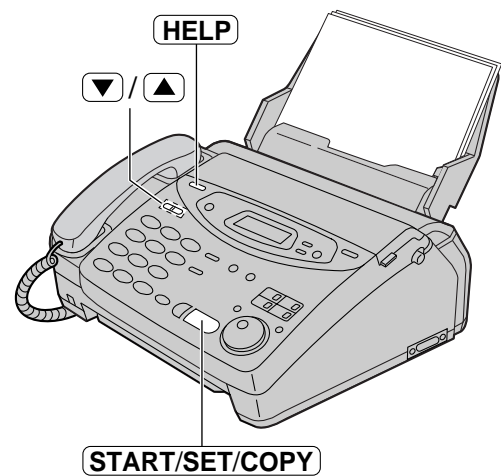

Finding the Controls

Location

■ For KX-FP105

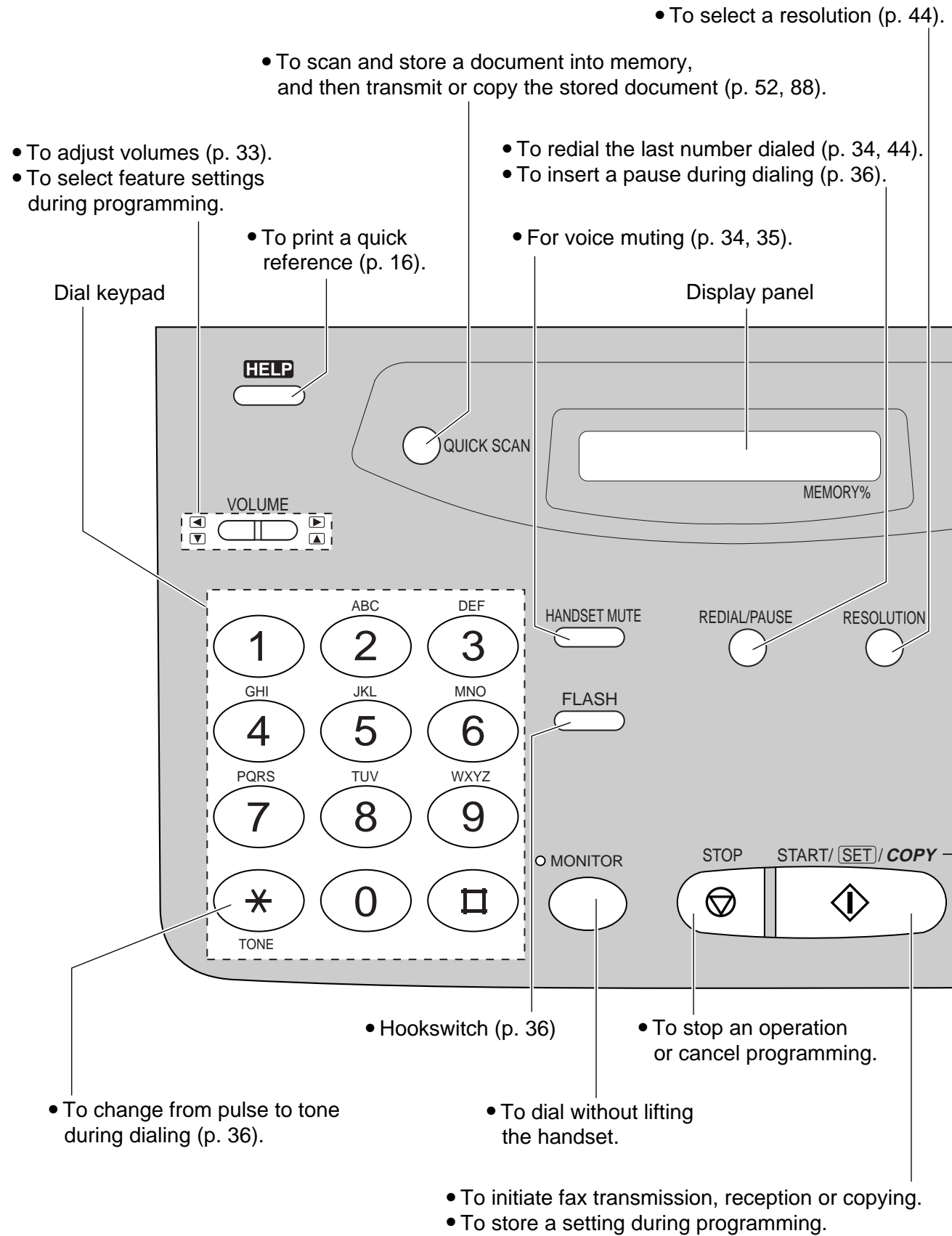

- For transmission to multiple stations (p. 53–55).
- For the One-Touch Dial (p. 38, 39, 45).
- Command keys (p. 31)

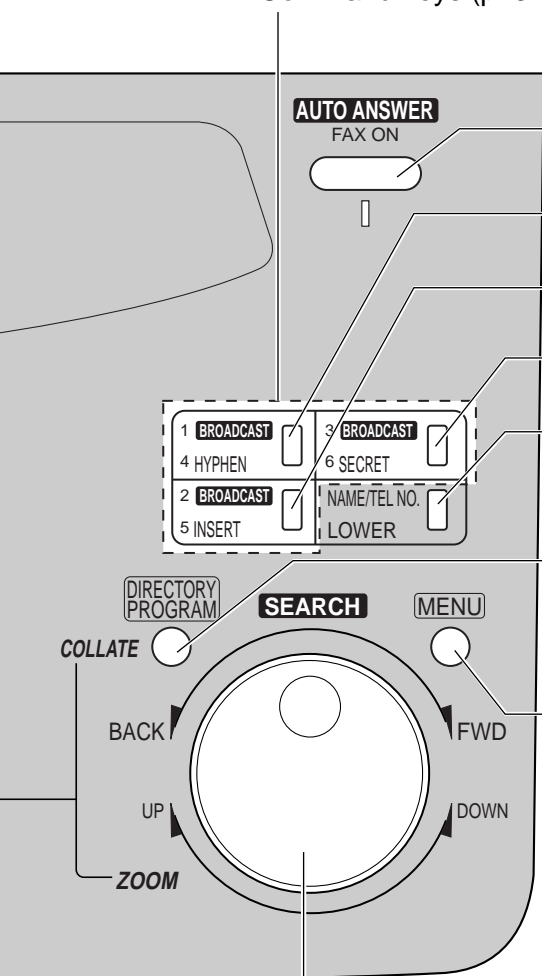

- To turn the auto answer mode on/off (p. 58).
- To insert a hyphen (p. 31, 38).
- To insert one character or one space (p. 30, 31).
- To keep the telephone number secret (p. 38, 40).
- To confirm a stored telephone number (p. 42).
- To select stations 4–6 for the One-Touch Dial (p. 38, 39, 45).
- To store or edit names and telephone numbers (p. 38, 40, 41, 53, 54).
- To choose “Collated” or “Uncollated” in the copy mode (p. 88).
- To initiate or exit programming.

- To search for a stored name (p. 42, 46).
- To select characters during programming (p. 31).
- To select the basic features during programming (p. 135).
- To select an enlargement/reduction rate in the copy mode (p. 88, 89).

Finding the Controls

Location

■ For KX-FM131

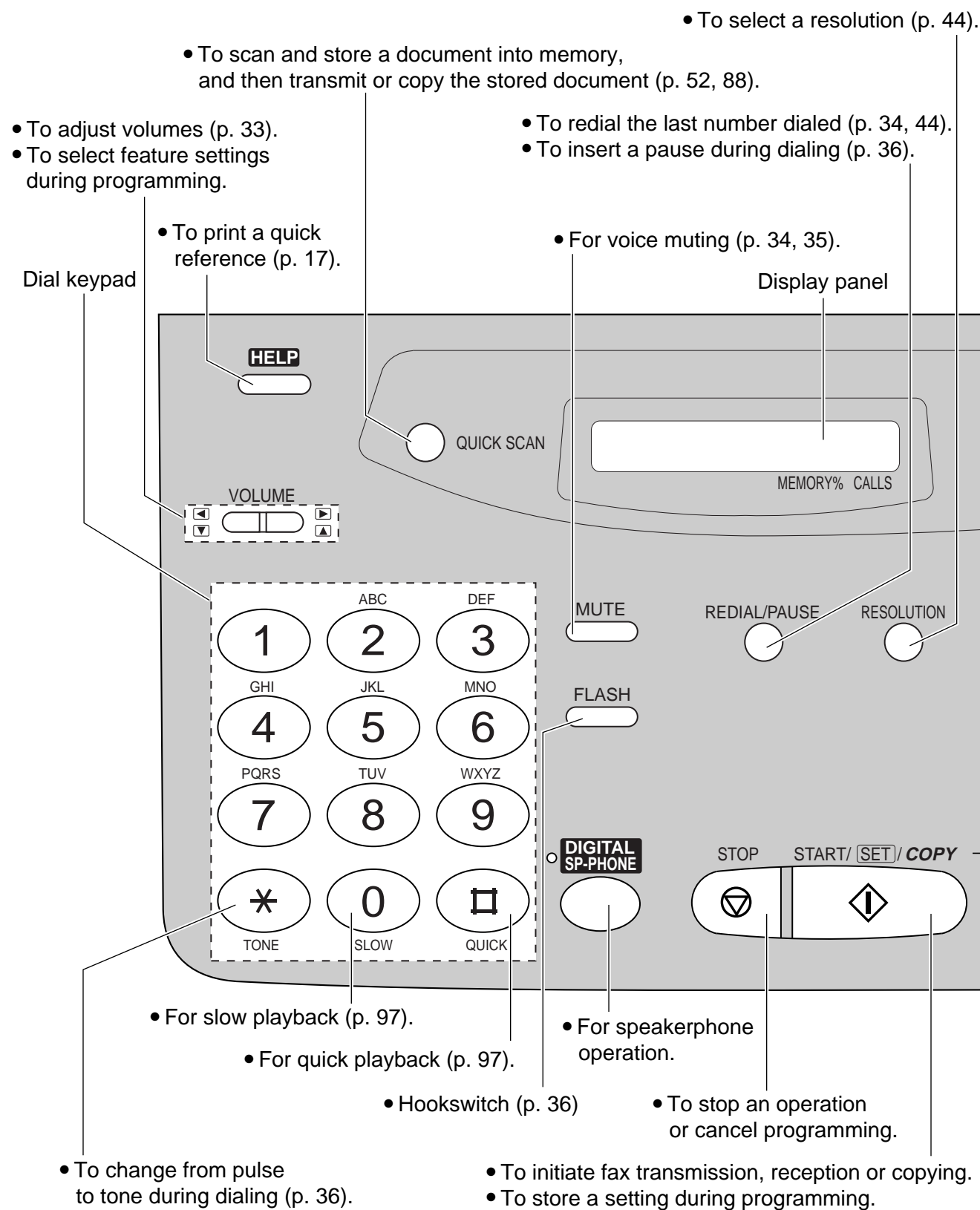

- To record your own greeting messages (p. 92).
- To record memo messages or telephone conversations (p. 98).

- To erase recorded messages (p. 96).
- To erase your own greeting messages (p. 93).

- To play recorded messages (p. 95).

- For transmission to multiple stations (p. 53–55).
- For the One-Touch Dial (p. 38, 39, 45).
- Command keys (p. 31)

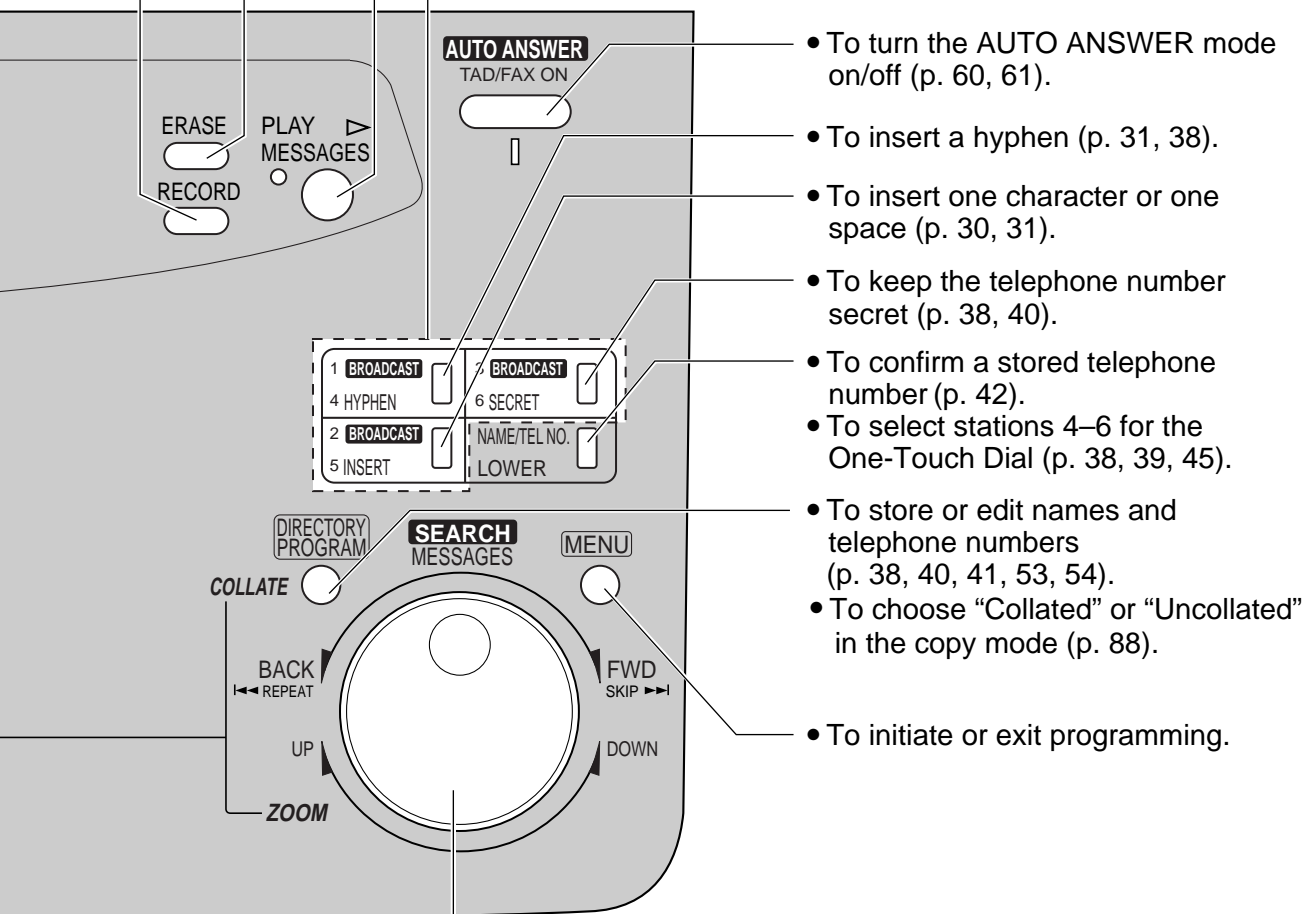

- To turn the AUTO ANSWER mode on/off (p. 60, 61).

- To insert a hyphen (p. 31, 38).

- To insert one character or one space (p. 30, 31).

- To keep the telephone number secret (p. 38, 40).

- To confirm a stored telephone number (p. 42).

- To select stations 4–6 for the One-Touch Dial (p. 38, 39, 45).

- To store or edit names and telephone numbers (p. 38, 40, 41, 53, 54).

- To choose “Collated” or “Uncollated” in the copy mode (p. 88).

- To initiate or exit programming.

- To search for a stored name (p. 42, 46).
- To select characters during programming (p. 31).
- To select the basic features during programming (p. 137).
- To skip and/or repeat recorded messages in the answering device (p. 97).
- To select an enlargement/reduction rate in the copy mode (p. 88, 89).

Finding the Controls

Overview

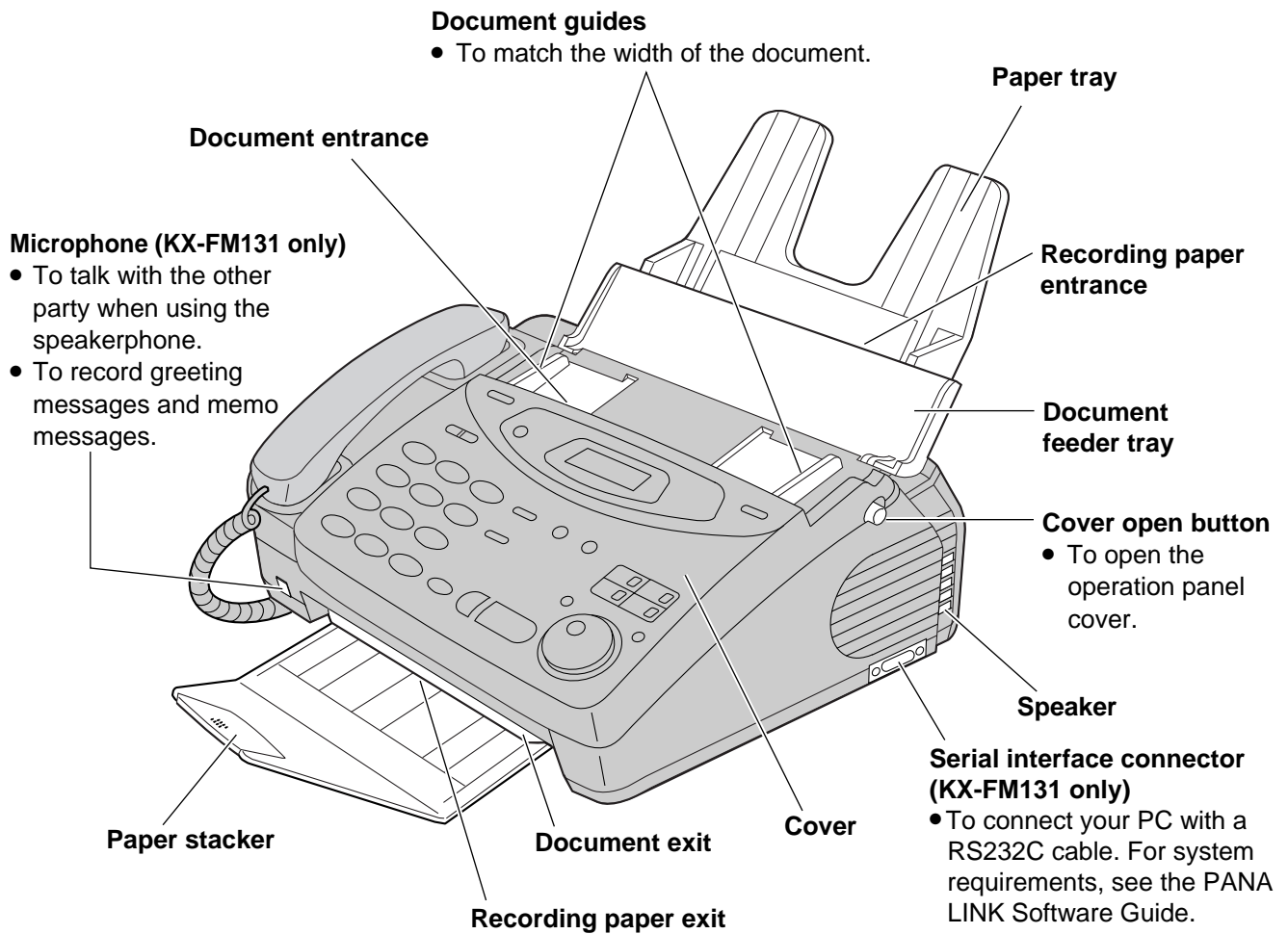

* The pictured model is KX-FP105.

Note:

- The document and recording paper will be ejected from the front of the unit. Install the unit on a desk or floor with a smooth surface and do not place anything in front of the unit.

Before installation

- 1** Remove the shipping tape.
- 2** Open the cover by pressing the cover open button.
- 3** Lift the film cartridge, remove the leaflet and replace the film cartridge.
- 4** Close the cover securely by pushing down on the dotted area at both ends.

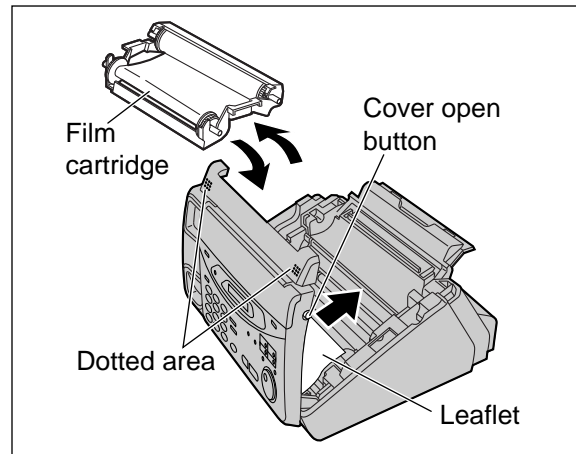
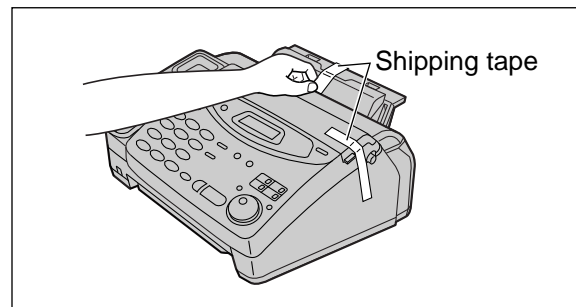

Setup

Paper tray

Insert the two tabs on the paper tray into the slots on the back of the unit.

- Do not place the unit in areas where the paper tray may be obstructed by a wall etc.

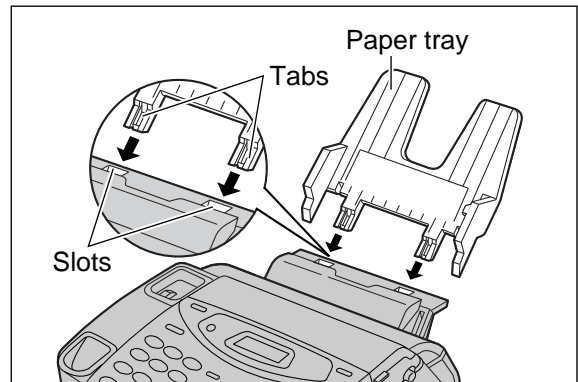

A4 paper guides

When using A4 size paper you need to install the guides for it.

- 1**
 - Ⓐ Insert the bottom tab on the A4 paper guide (left) into the lower slot.
 - Ⓑ Press the guide into the upper slot.
 - If the A4 paper guide cannot be installed, make sure the paper tray has been installed correctly.

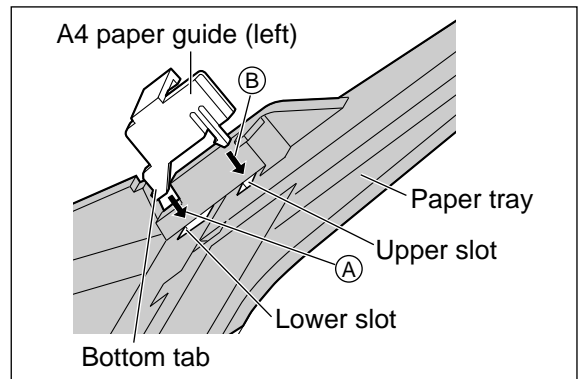

- 2**
 - Ⓐ Insert the bottom tab on the A4 paper guide (right) into the lower slot.
 - Ⓑ Press the guide into the upper slot.

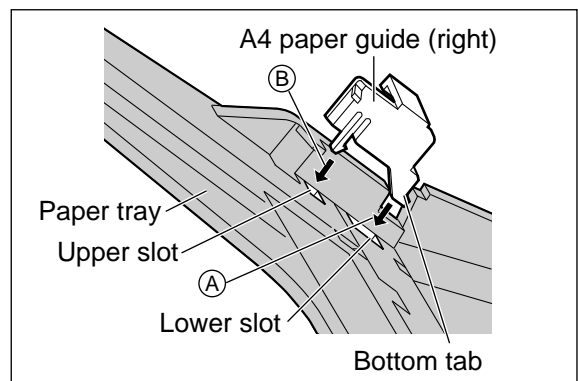

Note:

- When you remove the paper tray, be sure to take off A4 paper guides first, in order not to damage them.

Paper stacker

1 Remove the shipping tape from the paper stacker.

2 Lift the front of the unit and hold the aluminum sheet up to prevent it being bent by the paper stacker while inserting the paper stacker into the side slots.

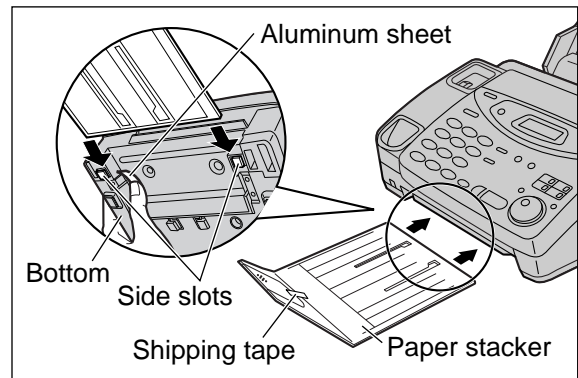

3 Confirm that the paper stacker is locked into the center slots and slide back.

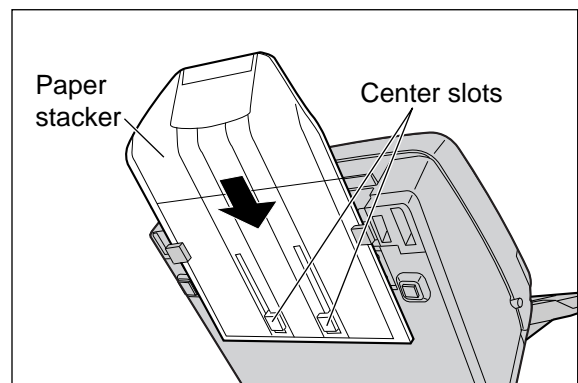

4 Slide the paper stacker forward until it stops.

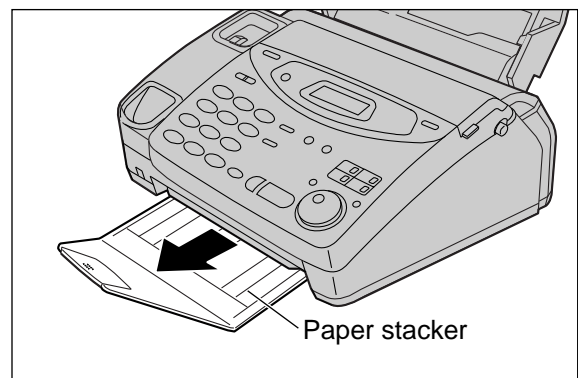

Setup

Using legal size paper

- 1 Press the dotted area on the paper stacker extender.

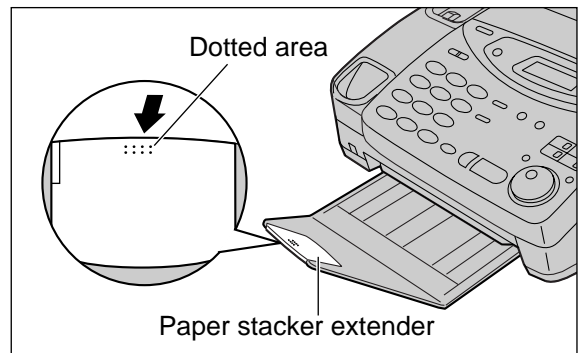

- 2 Open the paper stacker extender.

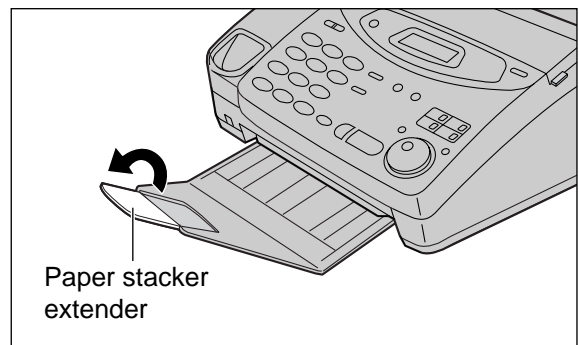

Recording paper

A4 size recording paper can be loaded. The paper tray can hold up to 150 sheets of 75 g/m² (20 lb.) paper. You may use 60 g/m² to 90 g/m² (16 lb. to 24 lb.) paper.

- 1 Fan the stack of paper to prevent a paper jam.

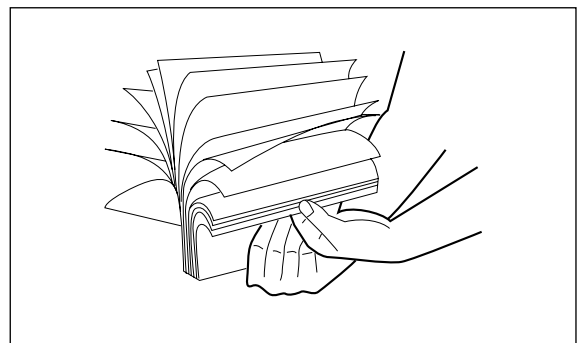

- 2** Pull the tension bar forward and hold open while inserting the paper.
- The height of the stack of the paper should not exceed the upper limit on the paper tray, otherwise the paper may jam or multi-feed.
 - The paper should not be over the tab.
 - If the paper is not inserted correctly, readjust the paper or the paper may jam.

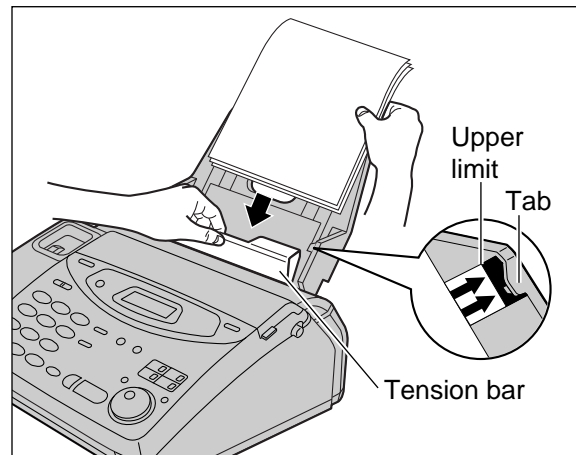
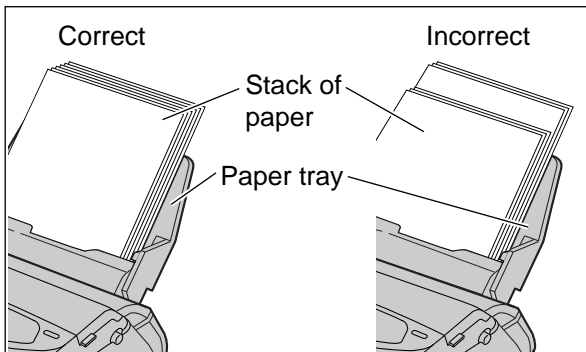

Note:

- **Avoid paper with a cotton and/or fiber content that is over 20%, such as letterhead paper or paper used for resumes.**
- **Do not use different types or thicknesses of paper in the paper tray at the same time. This may cause a paper jam.**
- **Avoid extremely smooth or shiny paper that is highly textured. Also avoid paper that is coated, damaged or wrinkled.**
- Avoid double-sided printing.
- Do not use paper printed from this unit for double-sided printing with other copiers or printers, or the paper may jam.
- Do not reinsert the ejected paper into the recording paper exit.
- Some paper only accepts print on one side. Try using the other side of paper when you are not happy with the print quality.

Adding paper to the paper tray

1. Pull the tension bar forward and hold open while removing all of the installed paper.
2. Add paper to the removed paper and straighten.
3. Fan the stack of paper.
4. Pull the tension bar forward and hold open while inserting the paper.

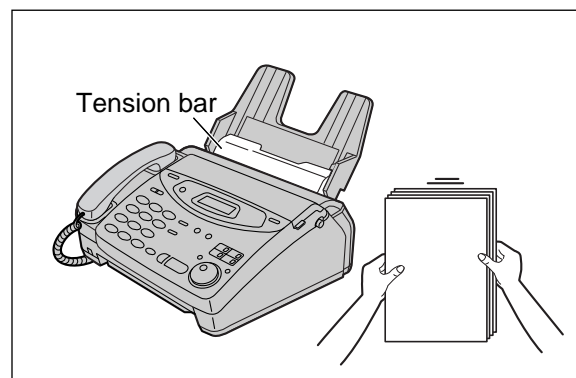

Connections

- 1 Connect the handset cord.
- 2 Connect the telephone line cord.
- 3 Connect the power cord.

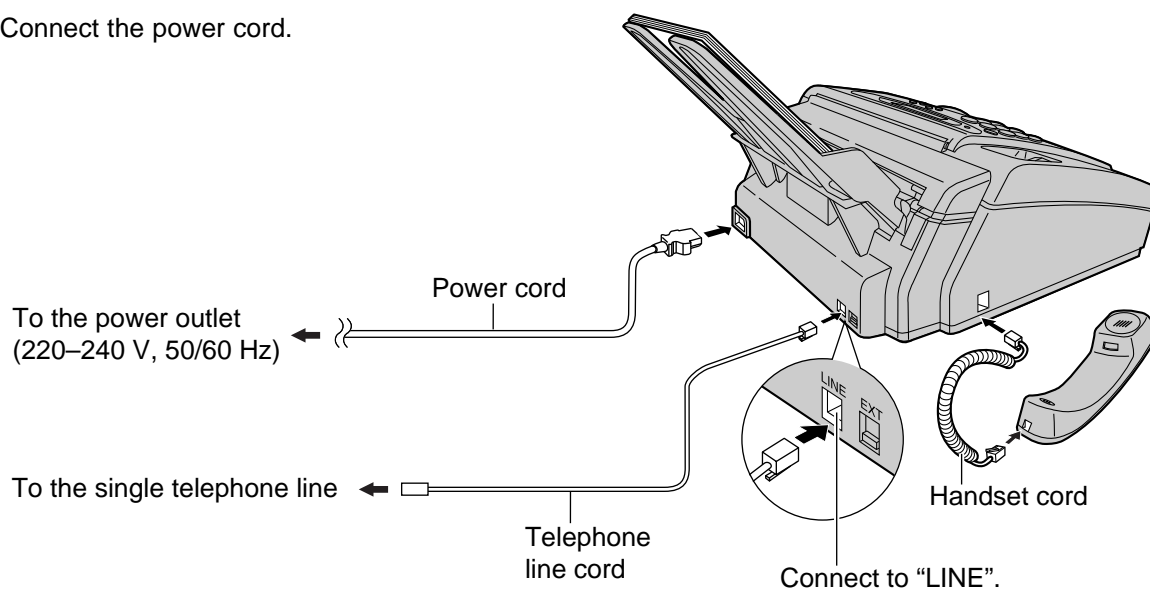

Note:

- When you operate this product, the power outlet should be near the product and easily accessible.
- If you want to connect an answering machine to the unit, see page 63 (KX-FP105 only).

Date and time, your logo and facsimile telephone number

You should program the date and time, your logo and facsimile telephone number. This information will be printed on each page transmitted from your unit.

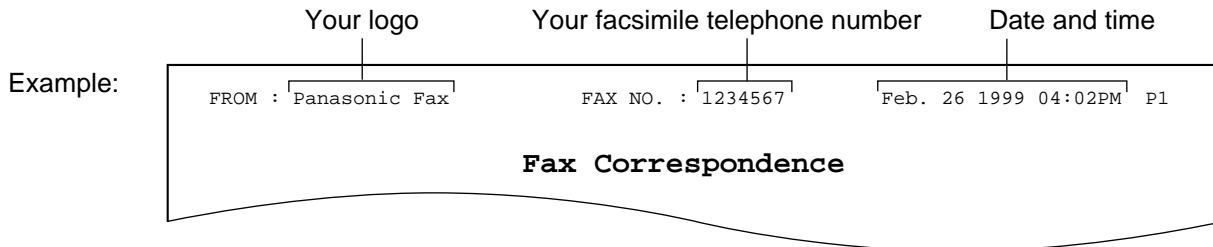

Setting the date and time

1 Press **MENU**.
Display: 1.SYSTEM SET UP

2 Press **⏏**, then **0 1**.
SET DATE & TIME

3 Press **START/SET/COPY**.
M:01/D:01/Y:99
Cursor

4 Enter the correct month/day/year by selecting 2 digits for each using the dial keypad.

Example: Aug. 10, 1999

Press **08 10 99**.
M:08/D:10/Y:99

5 Press **START/SET/COPY**.
TIME: 12:00AM

6 Enter the correct hour/minute by selecting 2 digits for each using the dial keypad. Press ***** to select "AM" or "PM".

Example: 3:15PM

1. Press **03 15**.
TIME: 03:15AM

2. Press ***** until "PM" is displayed.
TIME: 03:15PM

7 Press **START/SET/COPY**.
SETUP ITEM []

8 Press **MENU**.

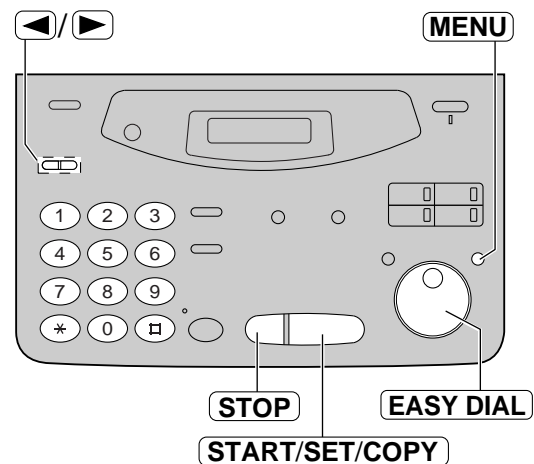

Note:

- You can enter the number by rotating **EASY DIAL** in steps 4 and 6. In this case, press **▶** to move the cursor.
- The accuracy of the clock is approximately ± 60 seconds a month.

To correct a mistake

- Press **◀** or **▶** to move the cursor to the incorrect number, and make the correction.
- If you press **STOP** while programming, the display will return to the previous one.

Setup

Setting your logo

The logo can be your company, division or name.

1 Press **MENU**.
Display: 1.SYSTEM SET UP

2 Press **#**, then **0 2**.
YOUR LOGO

3 Press **START/SET/COPY**.
LOGO=

4 Enter your logo, up to 30 characters, by using the dial keypad. See next page for details.

Example: Bill

1. Press **2** twice.
LOGO=B
Cursor

2. Press **4** six times.
LOGO=Bi

3. Press **5** six times.
LOGO=Bi

4. Press **▶** to move the cursor to the next space and press **5** six times.

LOGO=Bill

5 Press **START/SET/COPY**.
SETUP ITEM []

6 Press **MENU**.

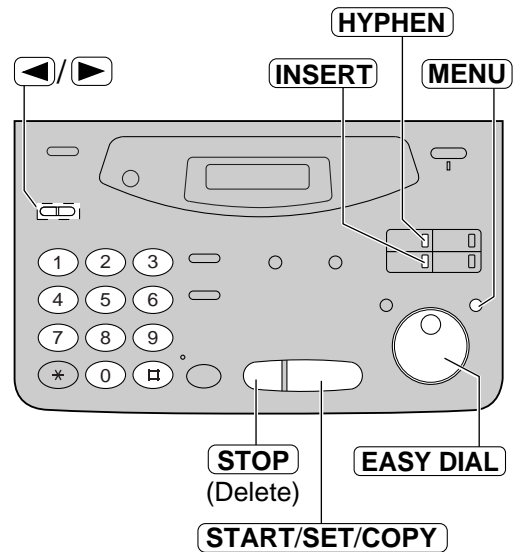

Note:

- You can enter characters by rotating **EASY DIAL** (see next page).

To correct a mistake

- Press **◀** or **▶** to move the cursor to the incorrect character, and make the correction.

To delete a character





- Move the cursor to the character you want to delete and press **STOP**.

To insert a character

- Press **◀** or **▶** to move the cursor to the position to the right of where you want to insert the character.
- Press **INSERT** (One-Touch Dial key 2) to insert a space and enter the character.

To select characters with the dial keypad

Pressing the dial keys will select a character as shown below.

Keys	Characters
①	1 [] { } + - / = , . _ ` : ; ?
②	A B C a b c 2
③	D E F d e f 3
④	G H I g h i 4
⑤	J K L j k l 5
⑥	M N O m n o 6
⑦	P Q R S p q r s 7
⑧	T U V t u v 8
⑨	W X Y Z w x y z 9
⑩	0 () < > ! " # \$ % & ¥ * @ ^ ' →
	HYPHEN key (To insert a hyphen.)
	INSERT key (To insert one character or one space.)
STOP	Delete key (To delete a character.)
	◀ key (To move the cursor to the left.)
	▶ key (To move the cursor to the right.) To enter another character using the same number key, move the cursor to the next space.

To select characters using the EASY DIAL

Instead of pressing the dial keys, you can select characters using the EASY DIAL.

1. Rotate **EASY DIAL** until the desired character is displayed.
2. Press  to move the cursor to the next space.
 - The character displayed in step 1 is inserted.
3. Return to step 1 to enter the next character.

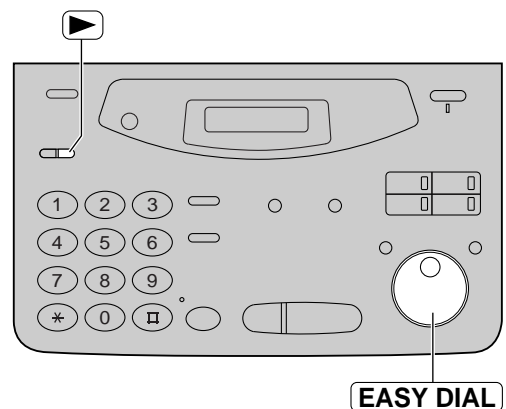

Display order of characters

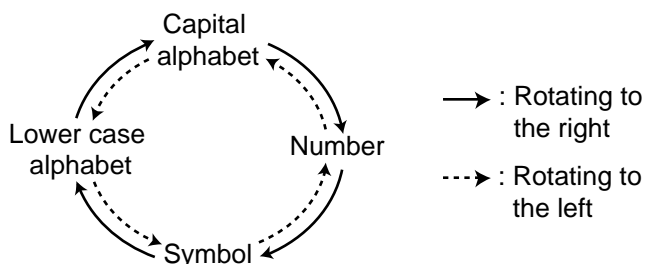

Setup

Setting your facsimile telephone number

- 1 Press **MENU**.
Display: 1.SYSTEM SET UP
- 2 Press **⏪**, then **0 3**.
YOUR FAX NO.
- 3 Press **START/SET/COPY**.
NO. =
- 4 Enter your facsimile telephone number up to 20 digits using the dial keypad.
Example: NO. =1234567
- 5 Press **START/SET/COPY**.
SETUP ITEM []
- 6 Press **MENU**.

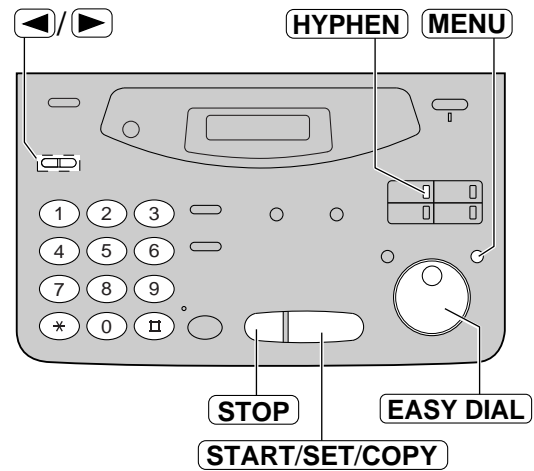

Note:

- You can enter your facsimile telephone number by rotating **EASY DIAL**. If using **EASY DIAL**, press **▶** to move the cursor.
- The ***** button replaces the digit with a "+" and the **#** button replaces it with a space.
Example (using the dial keypad): +234 5678
Press ***234#5678**.
- To enter a hyphen in a telephone number, press **HYPHEN** (One-Touch Dial key 1).

To correct a mistake

- Press **◀** or **▶** to move the cursor to the incorrect number, and make the correction.

To delete a number

- Move the cursor to the number you want to delete and press **STOP**.

Adjusting volumes

Ringer volume

4 levels (high/middle/low/off) are available.

While the unit is idle, press ▼ or ▲.

■ To turn the ringer off:

1. Press ▼ repeatedly until the following message is displayed.

Display: RINGER OFF= OK?
↑
YES: PRESS SET

2. Press **START/SET/COPY**.

- To turn the ringer back on, press ▲.

■ While the ringer volume is set to off:

The display will show the following message.

RINGER OFF

When a call is received, the unit will not ring and will display the following.

INCOMING CALL

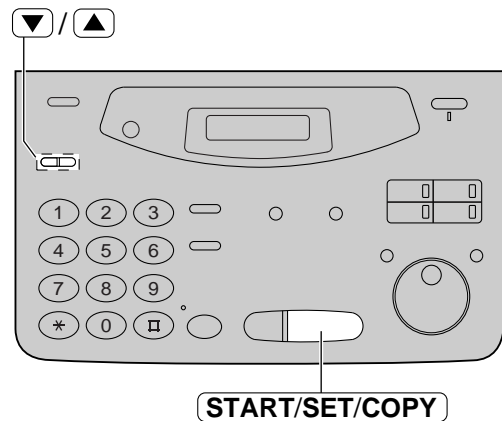

Handset receiver volume

3 levels (high to low) are available.

While using the handset, press ▼ or ▲.

Monitor/Speaker volume

8 levels (high to low) are available.

While using the monitor/speakerphone, press ▼ or ▲.

Fax voice guidance volume

(KX-FM131 only)

9 levels (high to off) are available.

While listening to the fax voice guidance, press ▼ or ▲.

Answering device volume

(KX-FM131 only)

9 levels (high to off) are available.

While listening to the recorded messages, press ▼ or ▲.

Making and Answering Calls

Voice calls - making

- 1 Lift the handset.

Display:

- 2 Dial the telephone number.

Example:

- If you misdial, hang up and dial again.

- 3 When the other party answers, speak with the handset.

- 4 When finished talking, replace the handset.

Helpful hints:

- For KX-FP105

You can press **MONITOR** instead of lifting up the handset in step 1.

Use the handset when the other party answers.

- For KX-FM131

You can press **DIGITAL SP-PHONE** instead of using the handset.

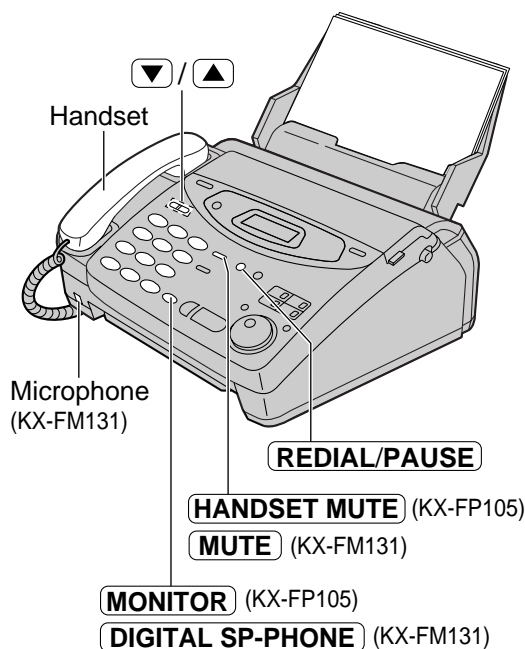

To redial the last number

1. Lift the handset.
2. Press **REDIAL/PAUSE**.
3. When the other party answers, speak with the handset.
 - If the line is busy when using the **MONITOR**/**DIGITAL SP-PHONE** button, the unit will automatically redial the number up to 14 times.
 - During redial, the following will be displayed.

Display:

To mute your voice to the other party

1. Press **HANDSET MUTE**/**MUTE** during a telephone conversation using the handset.

Display:

- The other party cannot hear you, but you can hear them.

2. To resume the conversation, press **HANDSET MUTE**/**MUTE** again.

- For KX-FM131

You can also mute your voice to the other party when using **DIGITAL SP-PHONE**.

Hints for the speakerphone operation (KX-FM131 only)

- Use the speakerphone in a quiet room.
- If you have difficulty hearing the other party, adjust the volume using **▼** or **▲**.
- If you and the other party speak at the same time, parts of your conversation will be cut off.
- To switch to the handset, lift the handset. To switch back to the speakerphone, press **DIGITAL SP-PHONE**.

Voice calls - answering

- 1 When the unit rings, lift the handset.
- 2 When finished talking, replace the handset.

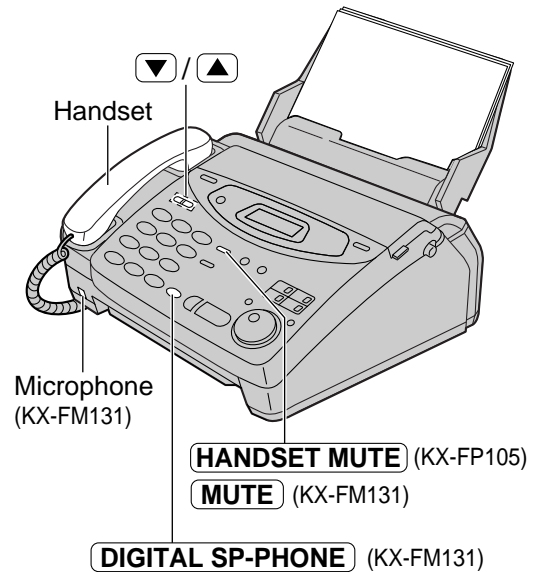

Helpful hint:

- You can press **DIGITAL SP-PHONE** instead of using the handset (KX-FM131 only).

To mute your voice to the other party

1. Press **HANDSET MUTE**/**MUTE** during a telephone conversation using the handset.

Display: <MUTE>

- The other party cannot hear you, but you can hear them.
2. To resume the conversation, press **HANDSET MUTE**/**MUTE** again.
- **For KX-FM131**
You can also mute your voice to the other party when using **DIGITAL SP-PHONE**.

Hints for the speakerphone operation (KX-FM131 only)

- Use the speakerphone in a quiet room.
- If you have difficulty hearing the other party, adjust the volume using **▼** or **▲**.
- If you and the other party speak at the same time, parts of your conversation will be cut off.
- To switch to the handset, lift the handset. To switch back to the speakerphone, press **DIGITAL SP-PHONE**.

Making and Answering Calls

TONE, FLASH and PAUSE buttons

TONE button

The **TONE** (*) button is used for rotary pulse dial services and allows you to temporarily change from pulse to tone mode during a dialing operation. When you hang up, the unit will automatically return to pulse mode.

FLASH button

The **FLASH** button functions like the hookswitch on a regular telephone. If you misdial a telephone number, press the **FLASH** button firmly.

The **FLASH** button also allows you to use special features of a host exchange (if connected) or local telephone company services such as call waiting. For further details, contact your host exchange supplier or local telephone company.

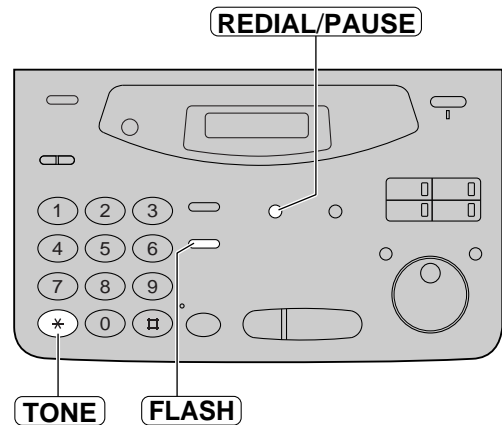

Note:

- TONE, FLASH and PAUSE can be stored into a telephone number in the One-Touch Dial and the EASY DIAL directory.

Entering pauses

When the **REDIAL/PAUSE** button is pressed during dialing, a pause will be inserted. Pressing **REDIAL/PAUSE** once creates a 5 second pause.

Example 1:

If your unit is connected to a host exchange, insert a pause to get an outside line.

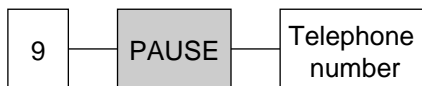

Line access code

Example 2:

If a transmission error occurs during an overseas transmission, add two pauses at the end of the telephone number.

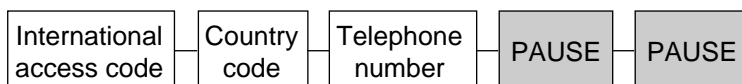

Dialing mode

(touch tone or pulse)

This feature is set to "TONE" as a pre-selected setting.

If you cannot dial, change the dialing mode setting to "PULSE" by following the instructions below.

- 1 Press **MENU**.
Display: 1. SYSTEM SET UP
- 2 Press **□**, then **1 3**.
DIALING MODE
- 3 Press **START/SET/COPY**.
MODE=TONE ▼▲
- 4 Press ▼ or ▲ to select "PULSE".
MODE=PULSE ▼▲
- 5 Press **START/SET/COPY**.
SETUP ITEM []
- 6 Press **MENU**.

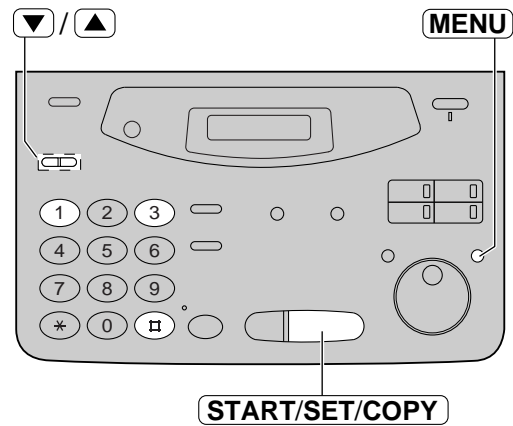

Setting the recording paper size

The recording paper size is selected by programming and should match the size of the paper on the paper tray.

A4: The recording paper width is 210 mm (8¹/₄") (pre-selected setting).

LTR/LEGAL: The recording paper width is 216 mm (8¹/₂"), letter or legal size paper.

- 1 Press **MENU**.
Display: 1. SYSTEM SET UP
- 2 Press **□**, then **1 6**.
PAPER SIZE
- 3 Press **START/SET/COPY**.
A4 ▼▲
- 4 Press ▼ or ▲ to select the desired setting.
- 5 Press **START/SET/COPY**.
SETUP ITEM []
- 6 Press **MENU**.

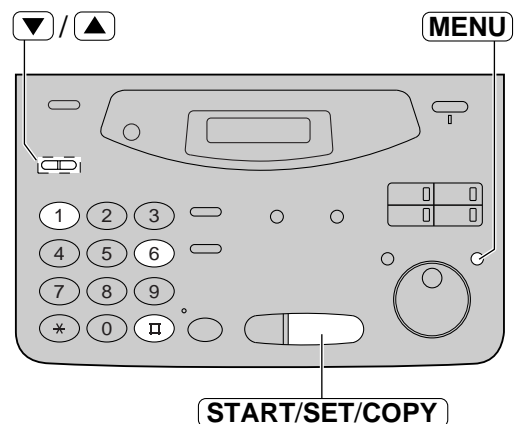

One-Touch Dial

Storing names and telephone numbers in the One-Touch Dial

The unit's memory allows you to use the One-Touch Dial for rapid access to your most frequently dialed numbers. 6 stations are available.

- One-Touch Dial keys 1, 2 or 3 can be used as One-Touch Dial keys (DIAL MODE) or as broadcast keys (BROADCAST). These functions cannot be used at the same time. For the broadcast function, see pages 53 to 55.

1 Press **DIRECTORY PROGRAM**.

Display:

↓

2 For stations 1–3
Press one of the One-Touch Dial keys.

▼▲

Press **START/SET/COPY** to go to the next prompt.

For stations 4–6

Press **LOWER**, then press one of the One-Touch Dial keys.

3 Enter the station name, up to 10 characters, following the instructions on page 31.

Example:

4 Press **START/SET/COPY**.

Example:

5 Enter the telephone number up to 30 digits.

Example:

- If you want to enter a hyphen, press **HYPHEN** (One-Touch Dial key 1).

6 Press **START/SET/COPY**.

↓

↓

- To program other stations, repeat steps 2 to 6.

7 Press **DIRECTORY PROGRAM** to exit the program.

Note:

- If "DIAL MODE" is not displayed when you select stations 1, 2 or 3 in step 2, the broadcast function has been set. To use the station as a One-Touch Dial key, press ▼ to select "DIAL MODE". The broadcast function will be canceled.
- A hyphen entered in a telephone number counts as two digits.

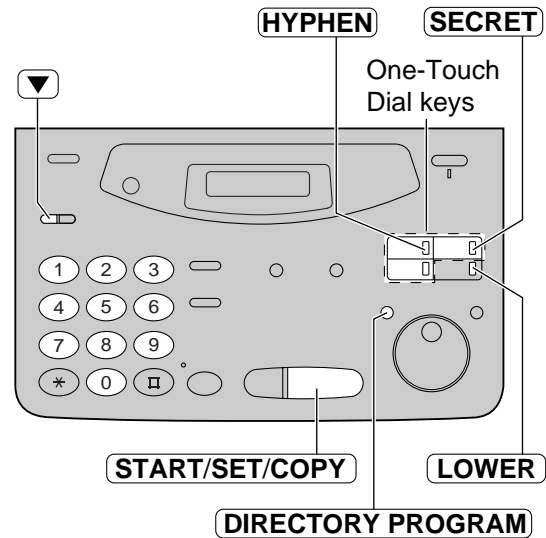

Helpful hint:

- You can confirm the stored items on the display (p. 42) or on the telephone number list (p. 127).

To keep the telephone number secret

Press **SECRET** (One-Touch Dial key 3) after entering the telephone number in step 5.

- A secret number cannot be viewed after this is set.
- The telephone number will not appear on the telephone number list.
- Pressing **SECRET** does not count as a digit.

To edit a stored station name and number

Enter the desired name in step 3.

Enter the desired number in step 5.

To erase a stored station name and number, see page 41.

Making a voice call using the One-Touch Dial

Before using this feature, program the desired names and telephone numbers into the One-Touch Dial (p. 38).

- 1 Lift the handset.

Display:

- Check that there are no documents in the document feeder tray.

- 2 **For stations 1–3**
Press the desired One-Touch Dial key.

For stations 4–6
Press **LOWER**, then press the desired One-Touch Dial key.

Example:

- 3 When the other party answers, speak with the handset.

- 4 When finished talking, replace the handset.

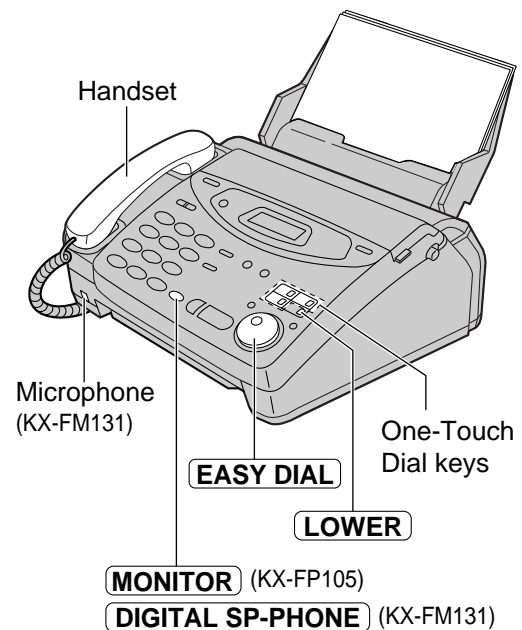

Helpful hints:

- You can confirm the stored items on the display (p. 42) or on the telephone number list (p. 127).
- You can use the EASY DIAL directory to select the station name instead of using the One-Touch Dial keys. Rotate **EASY DIAL** until the desired name is displayed, then lift the handset.
- **For KX-FP105**
You can press **MONITOR** instead of lifting up the handset in step 1.
Use the handset when the other party answers.
- **For KX-FM131**
You can press **DIGITAL SP-PHONE** instead of using the handset.

Storing names and telephone numbers in the EASY DIAL directory

For rapid access to frequently dialed numbers, the unit also provides a EASY DIAL directory (100 stations) in addition to the One-Touch Dial.

1 Press **DIRECTORY PROGRAM**.

Display:

↓

2 Rotate **EASY DIAL** until the following is displayed.

3 Enter the name, up to 10 characters, following the instructions on page 31.

Example:

4 Press **START/SET/COPY**.

5 Enter the telephone number up to 30 digits.

Example:

- If you want to enter a hyphen, press **HYPHEN**.

6 Press **START/SET/COPY**.

↓

- To program other items, repeat steps 3 to 6.

7 Press **DIRECTORY PROGRAM** to exit the program.

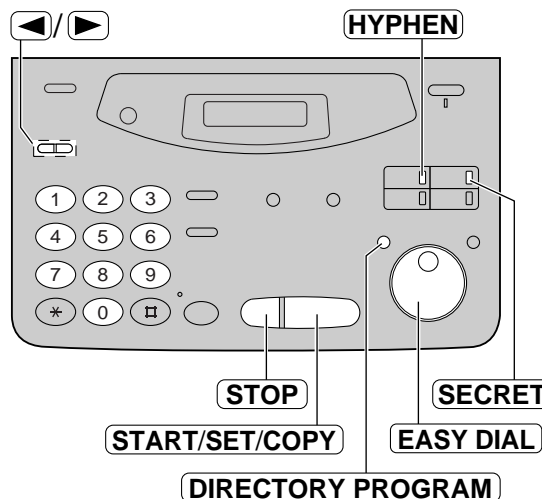

Helpful hint:

- You can confirm the stored items on the display (p. 42) or on the telephone number list (p. 127).

Note:

- When the following message is displayed in step 6, you can only store 5 more items.

Display:

- If there is no space to store new stations, the following message is displayed in step 1.

Erase unnecessary stations (p. 41).

- A hyphen entered in a telephone number counts as two digits.

To correct a mistake

- Press **◀** or **▶** to move the cursor to the incorrect character, and make the correction.

To delete a character or number

- Move the cursor to the character or number you want to delete and press **STOP**.

To keep the telephone number secret

Press **SECRET** (One-Touch Dial key 3) after entering the telephone number in step 5.

- A secret number cannot be viewed after this is set.
- The telephone number will not appear on the telephone number list.
- Pressing **SECRET** does not count as a digit.

Editing a stored name and number

- 1 Rotate **EASY DIAL** until the desired name is displayed.
Example:
- 2 Press **DIRECTORY PROGRAM**.
- 3 Press ***** to select "EDIT".
 - If you do not need to edit the name, go to step 5.
- 4 Edit the name by following the instructions on page 31.
- 5 Press **START/SET/COPY**.
Example:
 - If you do not need to edit the telephone number, go to step 7.

- 6 Edit the telephone number. For further details, see page 40.

- 7 Press **START/SET/COPY**.

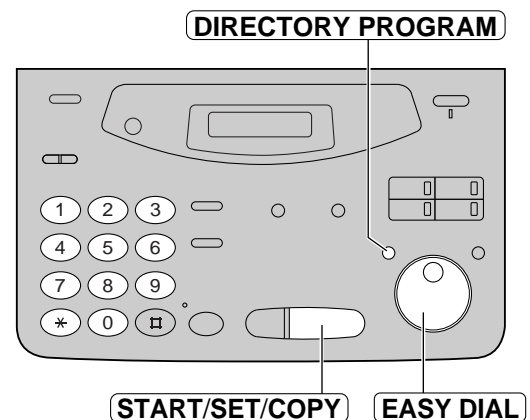

Erasing a stored name and number

You can erase a name and number stored in the EASY DIAL directory or One-Touch Dial.

- 1 Rotate **EASY DIAL** until the desired name is displayed.
Example:
- 2 Press **DIRECTORY PROGRAM**.
- 3 Press **#** to select "DELETE".

↓

 - If you do not want to erase the item, press **STOP**.

- 4 Press **START/SET/COPY**.

 - The stored name and number are deleted.

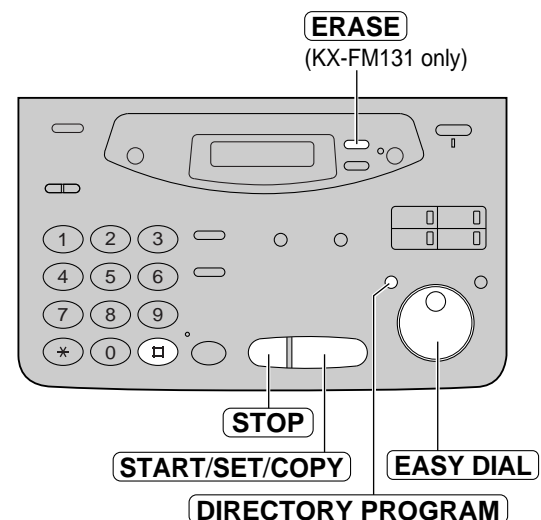

Note:

- You can use the following method to erase (KX-FM131 only).
 1. Rotate **EASY DIAL** until the desired name is displayed.
 2. Press **ERASE**.
 3. Press **START/SET/COPY**.

Making a voice call using the EASY DIAL directory

Before using this feature, program the desired names and telephone numbers into the directory (p. 40).

- 1 Rotate **EASY DIAL** until the desired name is displayed.

Example:

- 2 Lift the handset.
 - The unit will start dialing automatically.

- 3 When the other party answers, speak with the handset.

- 4 When finished talking, replace the handset.

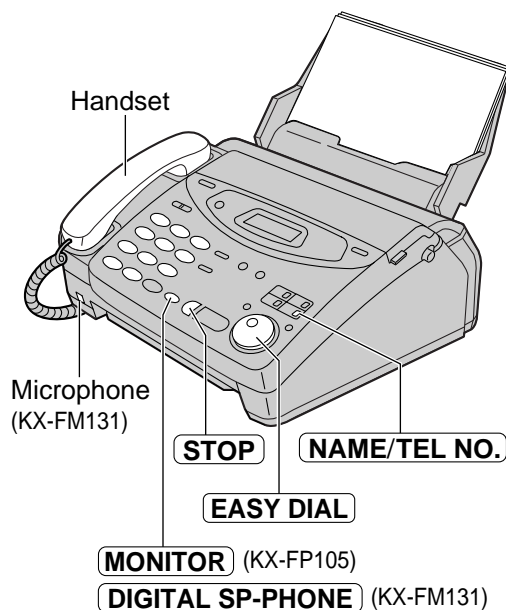

Helpful hints:

- You can confirm the stored items on the display (see below) or on the telephone number list (p. 127).
- **For KX-FP105**
You can press **MONITOR** instead of lifting up the handset in step 2.
Use the handset when the other party answers.
- **For KX-FM131**
You can press **DIGITAL SP-PHONE** instead of using the handset.

Note:

- If the desired name has not been stored, press **STOP** and dial the number manually.

To confirm the stored items on the display

1. Rotate **EASY DIAL** until the desired name is displayed.

Example:

2. Press **NAME/TEL NO.**.

- To stop the operation, press **STOP**.
3. Lift the handset.
 - The unit will automatically dial the number.

To search for a name by initial

Example: If you want to search for the name "Lisa"

1. Rotate **EASY DIAL** until any name is displayed.

Example:

2. Press **5** repeatedly until any name with the initial "L" is displayed (see the character table on page 31).

3. Rotate **EASY DIAL** to the right until "Lisa" is displayed.

- To stop the operation, press **STOP**.

4. Lift the handset.
 - The unit will automatically dial the number.

Note:

- If you want to search for symbols (not letters or numbers), press ***** in step 2.

Talking to the caller after fax transmission or reception

You can talk to the other party on the same call after a fax message is completed. This will save the added expense and time of making another call.

This feature only works when the other party's fax machine is equipped with a voice contact feature.

Initiating voice contact

- 1 Press **MONITOR** / **DIGITAL SP-PHONE** while transmitting or receiving documents.

Display: VOICE STANDBY

- Your unit will call the other party with a distinctive ring.
- When the other party answers, your unit will emit a distinctive ring.

- 2 Lift the handset to start talking.

Helpful hint:

- You can press **DIGITAL SP-PHONE** instead of lifting up the handset in step 2 (KX-FM131 only).

Note:

- If you initiate voice contact during transmission, the unit will call you with a distinctive ring after all of the documents have been transmitted.
- If you initiate voice contact during reception, the unit will call you with a distinctive ring after the current page of the document is received.

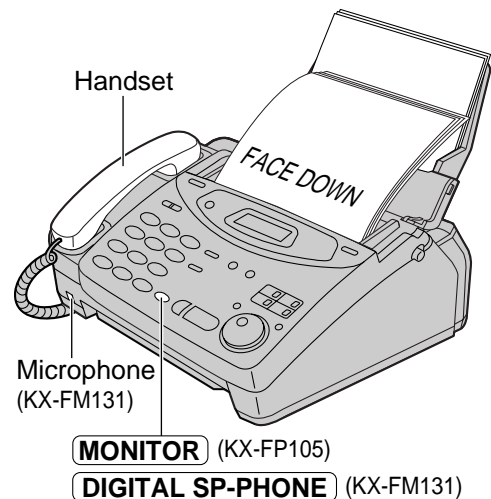

Receiving a request for voice contact

- 1 If the other party initiates voice contact, your unit will sound a distinctive ring and the following will be displayed.

Display: PLEASE PICK UP

- 2 Lift the handset within 10 seconds of the distinctive ring to start talking.

Helpful hint:

- You can press **DIGITAL SP-PHONE** instead of lifting up the handset in step 2 (KX-FM131 only).

Note:

- If you do not answer within 10 seconds of the distinctive ring;
 - If in the FAX ONLY, TEL or TEL/FAX mode, the line will be disconnected.
 - If in the TAD/FAX mode, your unit will play a greeting message and record an incoming voice message (KX-FM131 only).

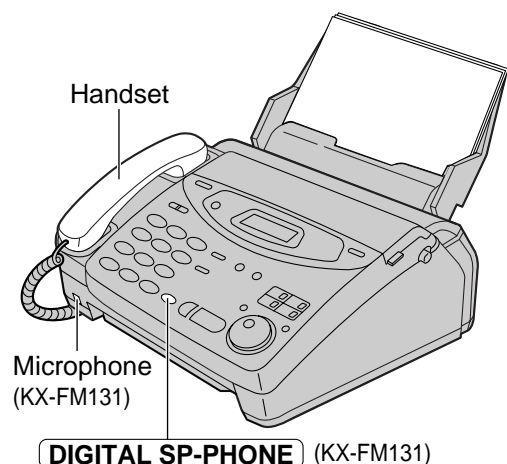

Sending Faxes

Sending a fax manually

- 1 Open the document feeder tray.
- 2 Adjust the width of the document guides to the size of the document.
- 3 Insert the document (up to 15 pages) FACE DOWN until a single beep is heard and the unit grabs the document.

Display:

- 4 If necessary, press **RESOLUTION** repeatedly to select the desired setting (see below).
- 5 Lift the handset or press **MONITOR** / **DIGITAL SP-PHONE**. (This step is optional. See note.)

- 6 Dial the fax number.

Example:

- 7 **When a fax tone is heard:**

Press **START/SET/COPY**, and replace the handset if using it.

OR

When the other party answers your call:

Lift the handset if using the monitor and ask them to press their start button. When a fax tone is heard, press **START/SET/COPY** and replace the handset if using it.

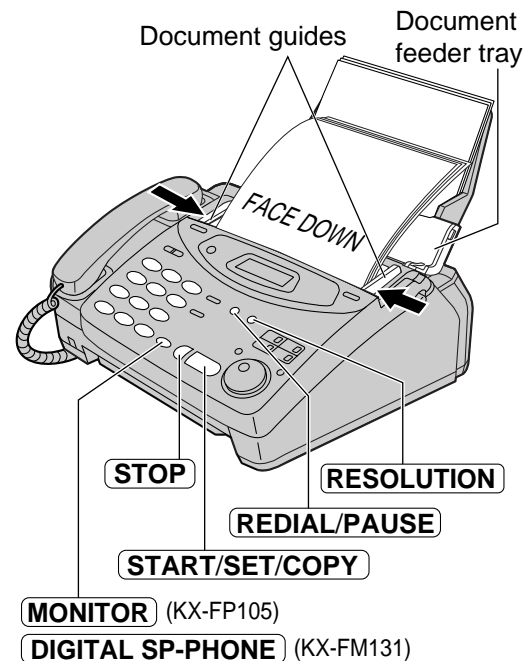

Note:

- If you cannot send a fax, check the problem by printing a journal report (p. 127) and see page 110 to solve the problem.
- Performing step 5 allows you to identify any possible problems in sending a fax. For the parties with whom you have experienced no problems, you can skip step 5. Dial the fax number and press **START/SET/COPY**.

To feed more than 15 pages at a time

Insert the first 15 pages of the document. Add the extra pages (up to 15) before the last page is fed into the unit.

To redial the last number

Press **REDIAL/PAUSE**.

- If the line is busy, the unit will automatically redial the number up to 5 times.
- During redial, the following will be displayed.

Display:

- To cancel redialing, press **STOP**.

To stop transmission

Press **STOP**.

To eject the document, press **STOP** again.

To select the resolution

Select the desired resolution according to the type of document.

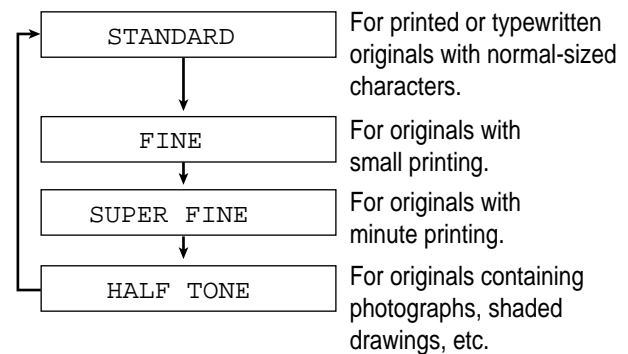

- Using the fine, super fine or half tone setting will increase the transmission time.
- If the resolution setting is changed during feeding, it will be effective from the next sheet.
- The super fine resolution only works with other compatible fax machines.

Sending a fax using the One-Touch Dial

Before using this feature, program the desired names and fax numbers into the One-Touch Dial (p. 38).

- 1** Open the document feeder tray.
- 2** Adjust the width of the document guides to the size of the document.
- 3** Insert the document (up to 15 pages) **FACE DOWN** until a single beep is heard and the unit grabs the document.

Display: STANDARD

- 4** If necessary, press **RESOLUTION** repeatedly to select the desired setting (p. 44).

- 5** **For stations 1–3**
Press the desired One-Touch Dial key.

For stations 4–6

Press **LOWER**, then press the desired One-Touch Dial key.

Example: FAX=<Sara>
↓
CONNECTING.....

- The unit will start transmission.

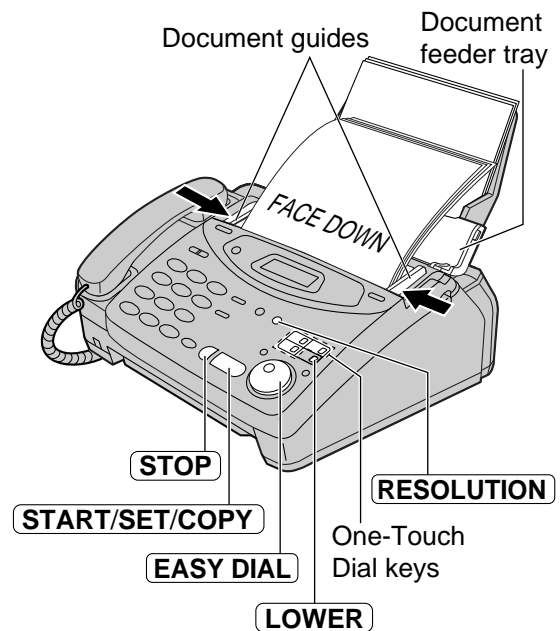

Fax/Copy

Helpful hints:

- You can confirm the stored items on the display (p. 42) or on the telephone number list (p. 127).
- You can use the EASY DIAL directory to select the station name instead of using the One-Touch Dial keys. Rotate **EASY DIAL** until the desired name is displayed, then press **START/SET/COPY**.
- The connecting tone will be heard during dialing to tell you the status of the other party's machine (p. 57).

If your unit does not send a fax

Verify that the number dialed is answered by the other party's machine.

- 1.** Lift the handset.
- 2. For stations 1–3**
Press the desired One-Touch Dial key.
For stations 4–6
Press **LOWER**, then press the desired One-Touch Dial key.

Fax auto redial

If the line is busy or there is no answer, the unit will automatically redial the number up to 5 times.

- This feature is also available for;
 - sending a fax using the EASY DIAL directory (p. 46).
 - delayed transmission (p. 51).
- During redial, the following will be displayed.

Display: WAITING REDIAL

- To cancel redialing, press **STOP**.

Free Manuals Download Website

<http://myh66.com>

<http://usermanuals.us>

<http://www.somanuals.com>

<http://www.4manuals.cc>

<http://www.manual-lib.com>

<http://www.404manual.com>

<http://www.luxmanual.com>

<http://aubethermostatmanual.com>

Golf course search by state

<http://golfingnear.com>

Email search by domain

<http://emailbydomain.com>

Auto manuals search

<http://auto.somanuals.com>

TV manuals search

<http://tv.somanuals.com>