

Service Manual

Cordless Combination Impact Drill & Driver

EY6901

CONTENTS

	Page
• Specifications	1
• Disassembly & Assembly Instructions	2 - 6
• Wiring Connection Diagram	7
• Schematic Diagram	7
• Troubleshooting	8 - 10
• Exploded View	11
• Replacement Parts List	12 - 13

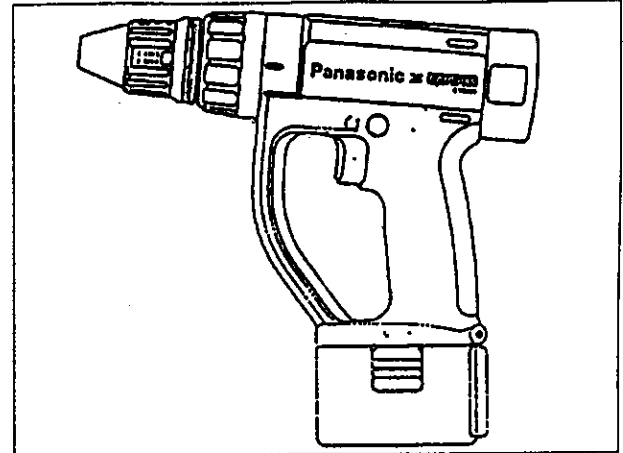

SPECIFICATIONS

DRILL/DRIVER

Motor voltage	: 12V DC
No load speed	LOW : 70 ~ 590 min ⁻¹ (r.p.m.) HIGH : 270 ~ 2,000 min ⁻¹ (r.p.m.)
Impact rate per minute	LOW : 1,050 - 8,850 min ⁻¹ (b.p.m.) HIGH : 4,050 - 30,000 min ⁻¹ (b.p.m.)
Speed reducer type	: Epicyclic gear
Chuck capacity	: 0.8mm, 1/32" - 10mm, 3/8"
Maximum torque	: 11.3Nm (115kg-cm, 99.7in.lbs.)
Impact strength	: 1,670N (170kgf, 370lbs.f)
Overall length	: 239mm, 10-11/16"
Mass (Weight) (with battery pack)	: 1.9kg (4.2lbs.)

BATTERY PACK

Storage battery	: Ni-Cd battery
Battery voltage	: 12V DC (1.2V × 10 cells)
Battery life	: Approx. 1,200 cycles (1cycle = 1 charge / 1 discharge)

BATTERY CHARGER

Input	: 120V AC
Mass (Weight)	: 0.66kg (1.45lbs.)
Charging time	: Approx. 15/20 min.

STANDARD EQUIPMENT

Battery charger , Battery pack , Tool case

Panasonic

© 1996 Matsushita Electric Works, Ltd.
All rights reserved. Unauthorized copying and
distribution is a violation of law.

⚠ WARNING

This service literature is designed for experienced repair technicians only and is not designed for use by the general public. It does not contain warnings or cautions to advise non-technical individuals of potential dangers in attempting to service a product. Products powered by electricity should be serviced or repaired only by experienced professional technicians. Any attempt to service or repair the product or products dealt with in this service information by anyone else could result in serious injury or death.

DISASSEMBLY INSTRUCTIONS**■ HOW TO REMOVE THE KEYLESS DRILL CHUCK.**

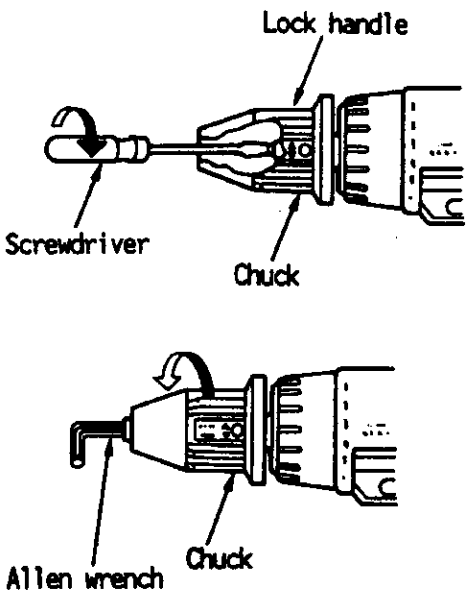
Ref. No. 1A	Procedure 1A	Removal of the keyless drill chuck.
	 <p>The diagram consists of two parts. The top part shows a side view of the drill chuck with a screwdriver inserted into the chuck fastening screw. An arrow indicates the screw is being turned clockwise. Labels include 'Screwdriver' and 'Chuck'. The bottom part shows a similar side view with an Allen wrench inserted into the chuck. An arrow indicates the wrench is being turned counter-clockwise. Labels include 'Allen wrench' and 'Chuck'. A 'Lock handle' is also labeled on the top part of the diagram.</p>	<ol style="list-style-type: none"> 1. Set the clutch handle to drill position. 2. Turn the lock handle in the counterclockwise direction to open the chuck claws. 3. Remove the chuck fastening screw inside the chuck by turning it in the clockwise direction with a slotted head screwdriver. <p>NOTE : If the chuck fastening screw will not come loose, insert the allen wrench into the chuck and lightly tap in the clockwise direction with a hammer to tighten the chuck, and then loosen the chuck fastening screw.</p> <ol style="list-style-type: none"> 4. Insert the allen wrench into the chuck, and turn in the counterclockwise direction, holding the unit by the vise to remove the chuck.

■ HOW TO DISASSEMBLE THE MAIN UNIT. (Housing AB set can be opened without disassembling the chuck.)

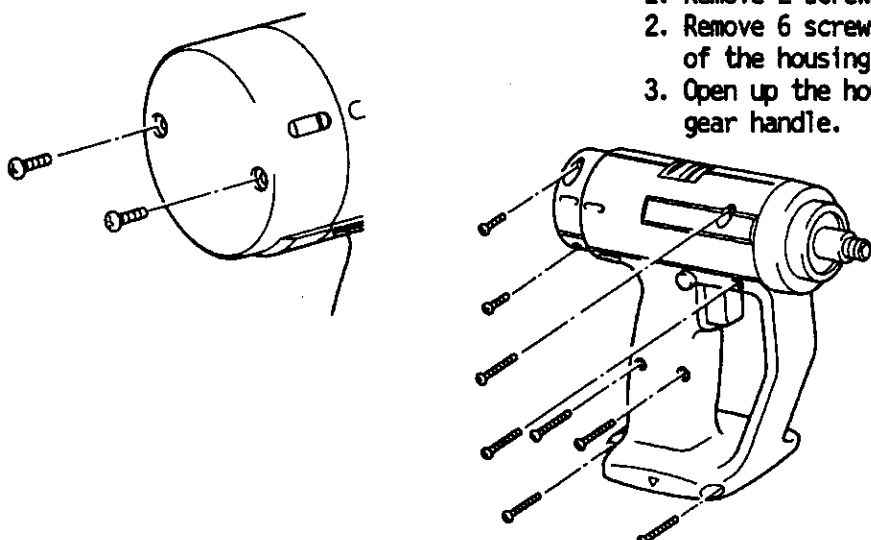
Ref. No. 1B	Procedure 1B	Removal of the housings.
	 <p>The diagram consists of two parts. The left part shows a circular housing cover with two screws being removed. The right part shows the main unit of the drill with several screws being removed from the housing. Labels include 'C' on the housing cover and 'K3-20' and 'K3-12' on the screws.</p>	<ol style="list-style-type: none"> 1. Remove 2 screws of the housing cover. 2. Remove 6 screws (K3-20) and 2 screws (K3-12) of the housing. 3. Open up the housings and remove the change-gear handle.

Ref. No. 2B

Procedure 1B → 2B

Removal or assembly of the motor.

(Removal of the motor.)

1. Remove the motor with the gear block from the housing.
2. Separate the motor from the gear block by twisting the motor to unlock tabs.

(Assembly of the motor.)

3. Adjust the raised line of the gear block to the groove of the motor.

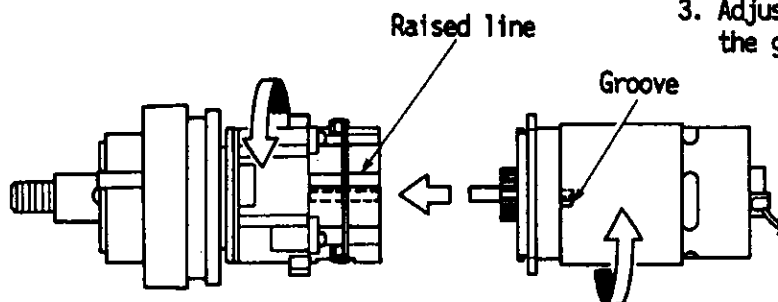

Ref. No. 3B

Procedure 1B → 2B → 3B

Removal of the driving block.

1. Set the clutch handle B to position 1 before replacing the driving block from the housing.
2. Loosen 3 screws of clutch handle A and remove the clutch handle from the driving block.
3. Pull out 2 pins ($\phi 2 \times 31.8$) by pressing down on the clutch handle B and the driving shaft.
4. After removing the clutch handle B, the internal parts of the driving block can be removed one after another.

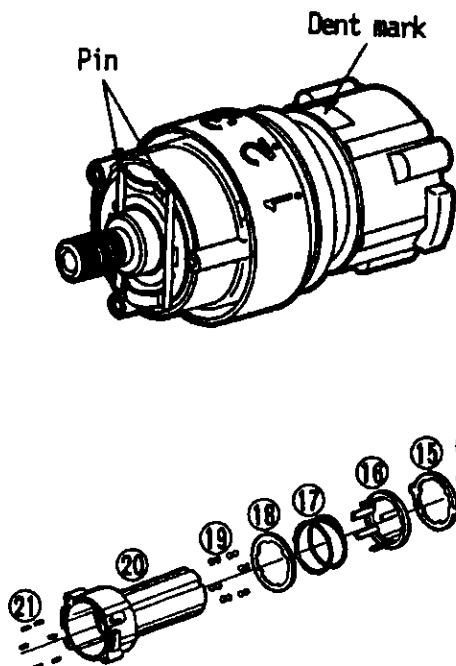
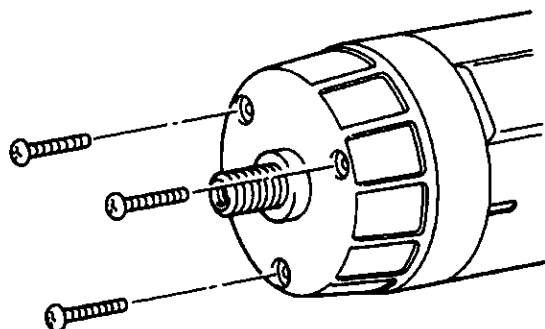

driving shaft → spring → change plate (2pcs) → cam A → vibration spring → click plate → adjust ring → clutch spring → clutch plate → steel ball (12pcs) → roller pin (6pcs)

ASSEMBLY INSTRUCTIONS

■ HOW TO ASSEMBLE THE DRIVING BLOCK AND GEAR CASE ASSEMBLY.

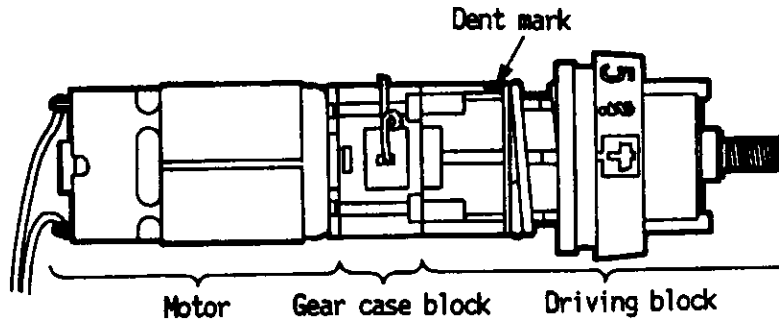

Ref. No. 1A	Procedure 1A	Assembly of the driving block.
		<ol style="list-style-type: none"> 1. Assemble the clutch plate, clutch spring, and the adjust ring to the outside of the clutch case. 2. The click plate has its own correct direction for proper assembly. Adjust the (A) groove of the clutch case to the protrusion part of the click plate.
		<ol style="list-style-type: none"> 3. Assemble the vibration spring and cam A into the clutch case. 4. When assembling the change plates, make sure that the protrusion side of the change plates face inside of the clutch case. 5. Insert the spring to the driving shaft and assemble them to the clutch case.

Ref. No. 2A

Procedure 1A → 2A

Assembly of the clutch handle.

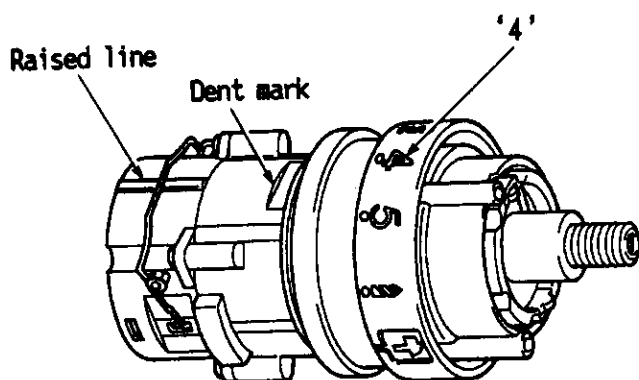

1. Set the clutch handle B to position 4 toward the dent part of the clutch case.
2. Insert 2 pins ($\phi 2 \times 31.8$) by pressing down the clutch handle B and the driving shaft.
3. The change ring has its own correct direction.
Confirm the direction when the change ring is inserted into the clutch handle.
4. Select the clutch handle B to the hammer position before assembling the clutch handle A to the gear block.
5. Adjust the protrusion parts of the change plate with the groove parts of the change ring inside of the clutch handle A.
6. Tighten 3 screw of the clutch handle A.

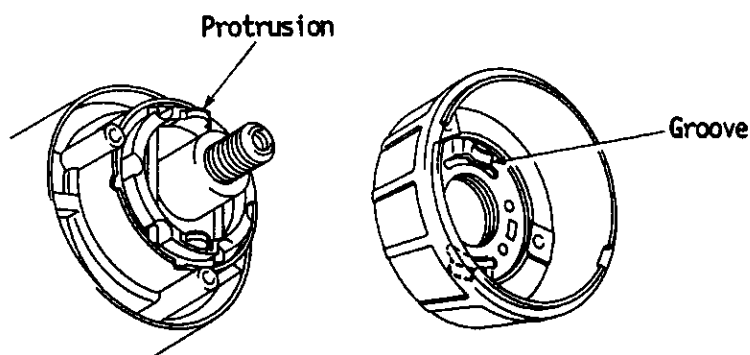
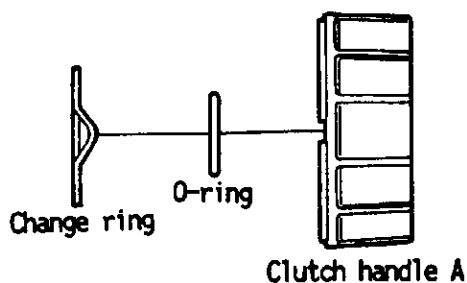

Ref. No. 3A

Procedure 1A → 2A → 3A

Assembly of the gear case.

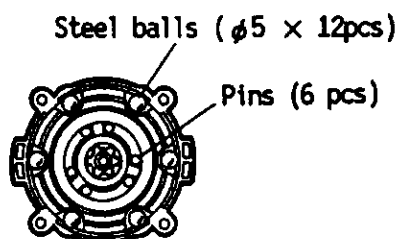

1. Reinstall 2 pieces of steel balls into each of the 6 holes.
2. Insert 6 pins into the clutch case.
3. Assemble the carrier, ring gear and 3 pieces of planet gear.
4. Align the dent part of the clutch case with the raised line of the gear case. And tighten them with 4 screws.
5. Assemble the ring gear B, carrier A, planet gear A, carrier B, ring gear A, planet gear B, and thrust plate.
Note : Ring gear B has its own correct direction for proper assembly.

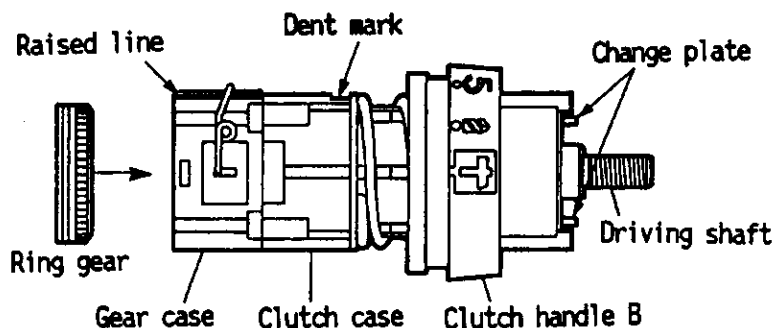

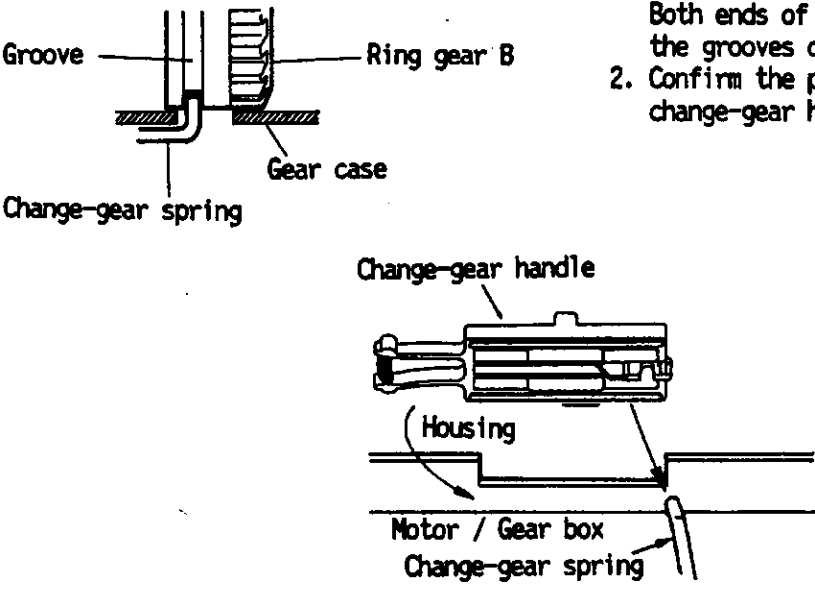
Ref. No. 4A	Procedure 1A → 2A → 3A → 4A	Assembly of the change-gear spring and handle.
		<ol style="list-style-type: none"> 1. Change-gear spring has its own correct direction when inserting it into the housing. Both ends of spring must be put into the grooves of the ring gear B. 2. Confirm the proper position of the change-gear handle when it is assembled.

■ HOW TO ASSEMBLE THE BATTERY CHARGER.

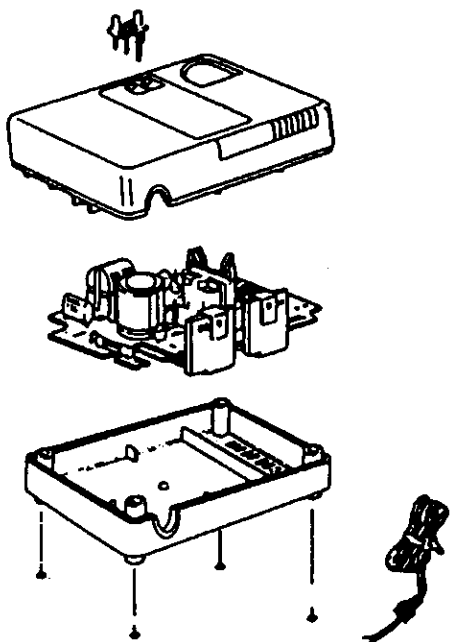
Ref. No. 1B	Procedure 1B	Assembly of the battery charger.
		<ol style="list-style-type: none"> 1. Assemble the module block (power cord, power transformer, and module) to housing A. Confirm that the LEDs appear through the hole in housing A. 2. Set the bushing of the power cord to the housing A. NOTE : Avoid pinching lead wires, dress into housing recess and around screw posts etc. 3. After assembly, measure the battery terminals between (S) and (-). It is OK, if it is approx. 3V DC.

SCHEMATIC DIAGRAM

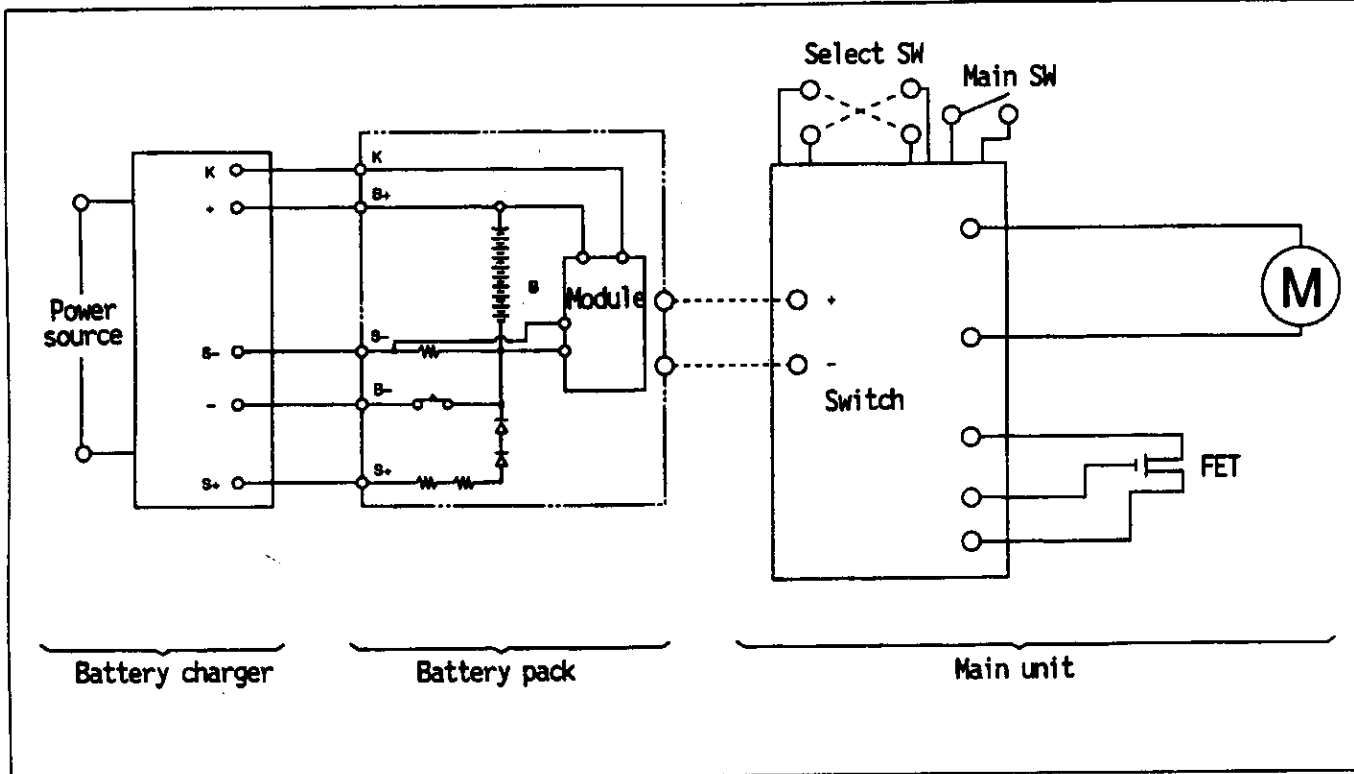

WIRING CONNECTION DIAGRAM

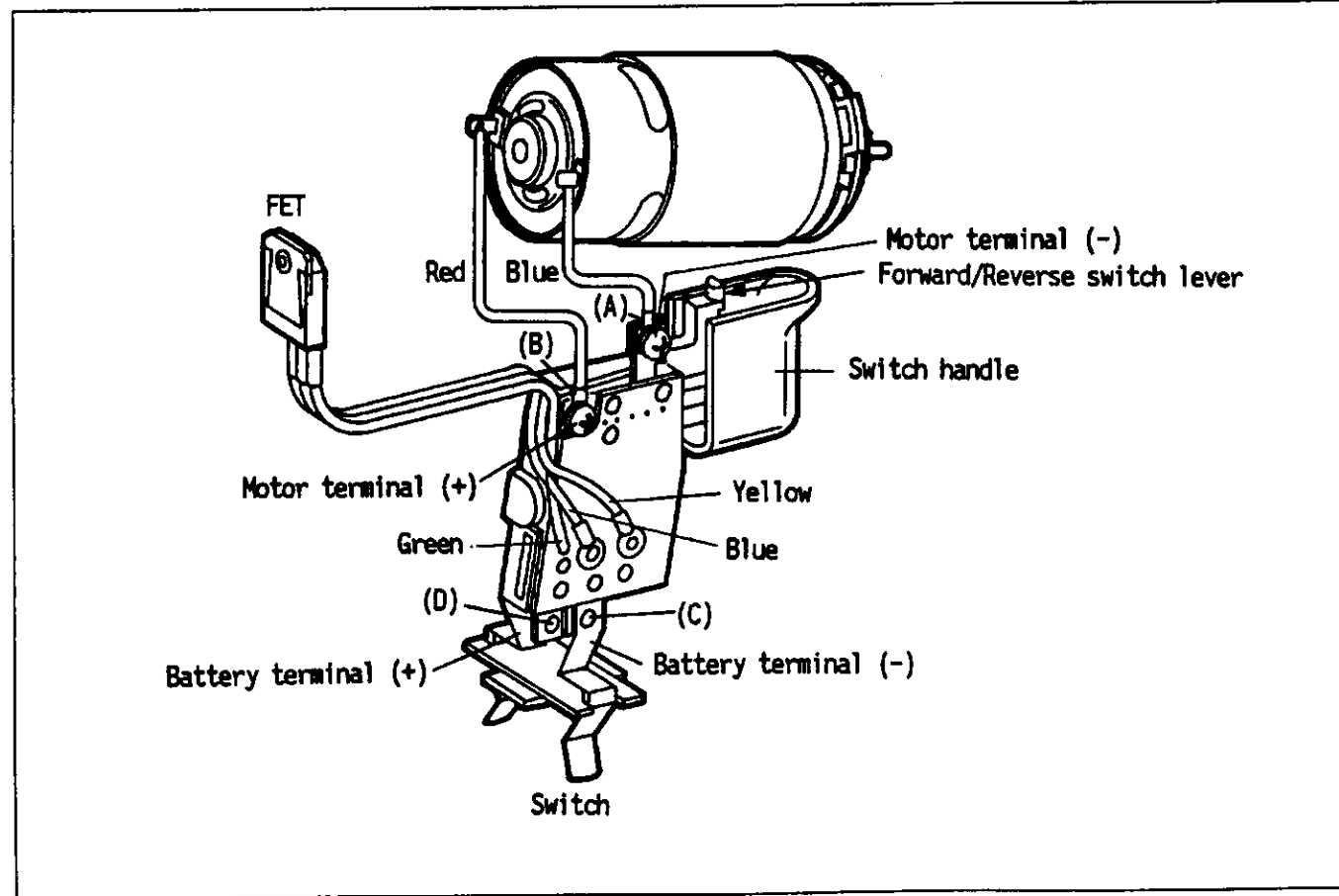

TROUBLESHOOTING GUIDE (Refer to WIRING CONNECTION DIAGRAM)

■ CHECK POINTS FOR ELECTRICAL PARTS

< TROUBLE >

< CHECK >

< REMEDY >

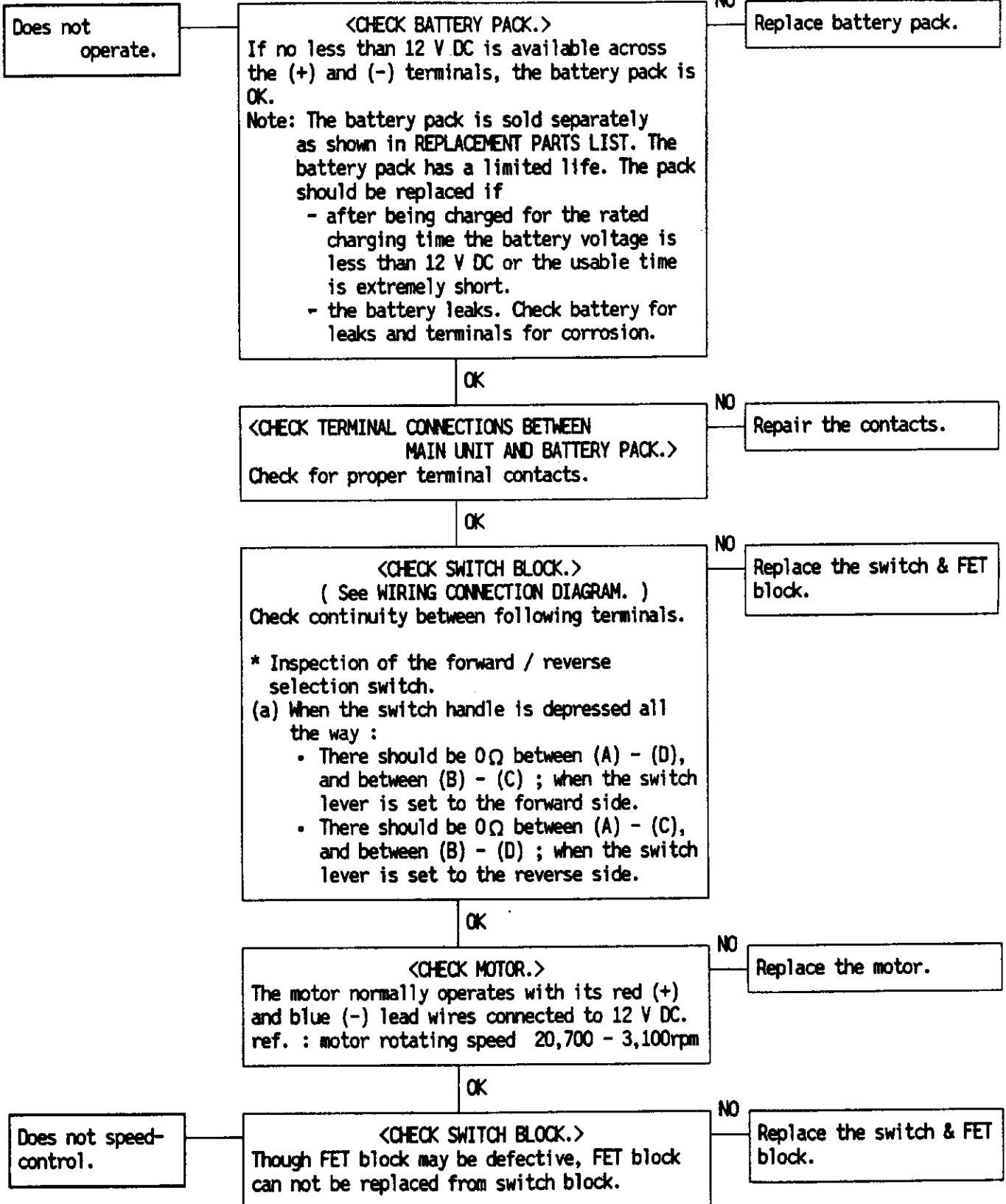

■ CHECK POINTS FOR DRIVING BLOCK
 < TROUBLE >

< CHECK >

< REMEDY >

Does not vibrate or weakness of vibration. (When setting the clutch handle to .)

<CHECK DRIVING SHAFT (CAM B) AND CAM A.>
 Check the wear condition of the driving shaft (cam B) and the cam A inside of the clutch case.

NO
 Replace driving shaft or cam A.

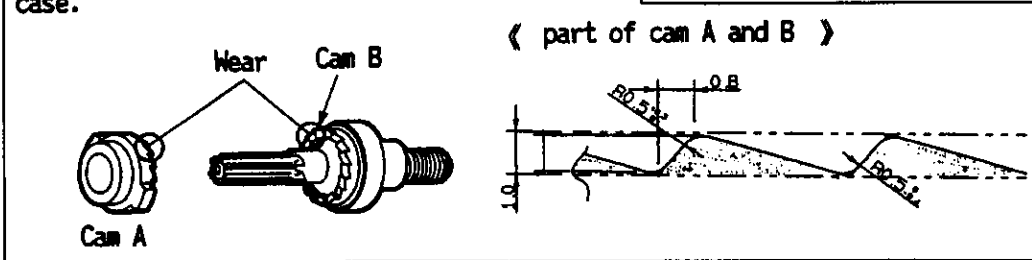

OK

<CHECK CHANGE PLATES.>
 Check the wear condition of protrusion parts for both side of change plates.

NO
 Replace change plates.

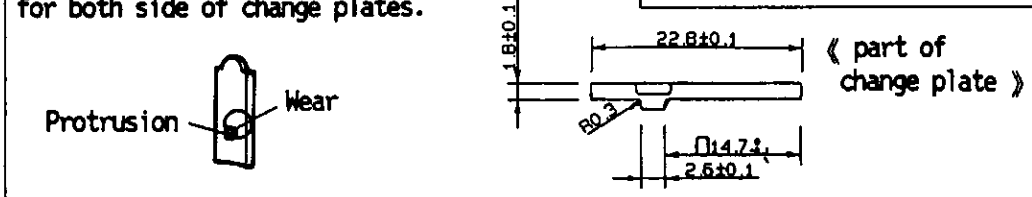

Weakness of clutch operation.

<CHECK CLUTCH HANDLE A.>
 Check the wear condition of torque changing cam inside of clutch handle A.

NO
 Replace clutch handle A.

OK

<CHECK RING GEAR.>
 Check the wear condition of the protrusion parts of ring gear.

NO
 Replace ring gear.

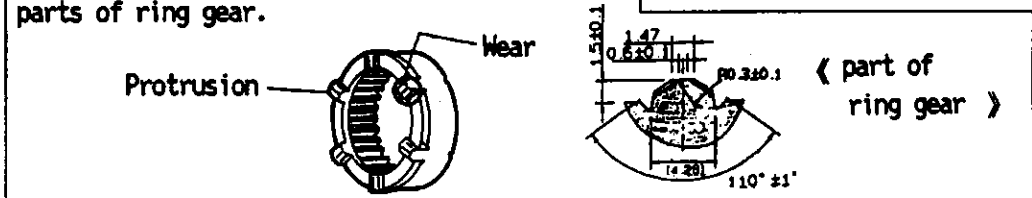

OK

<CHECK ADJUST RING.>
 Check the wear condition of tip parts of adjust ring.

NO
 Replace adjust ring.

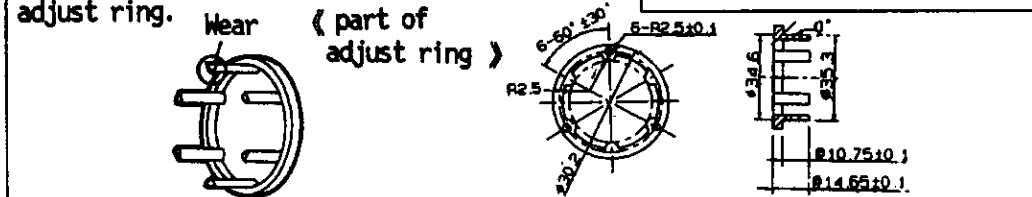

The bit-locking function does not work.



<CHECK ROLLER AND CARRIER.>
 Check the wear condition of roller set and carrier.

NO
 Replace roller set or carrier.

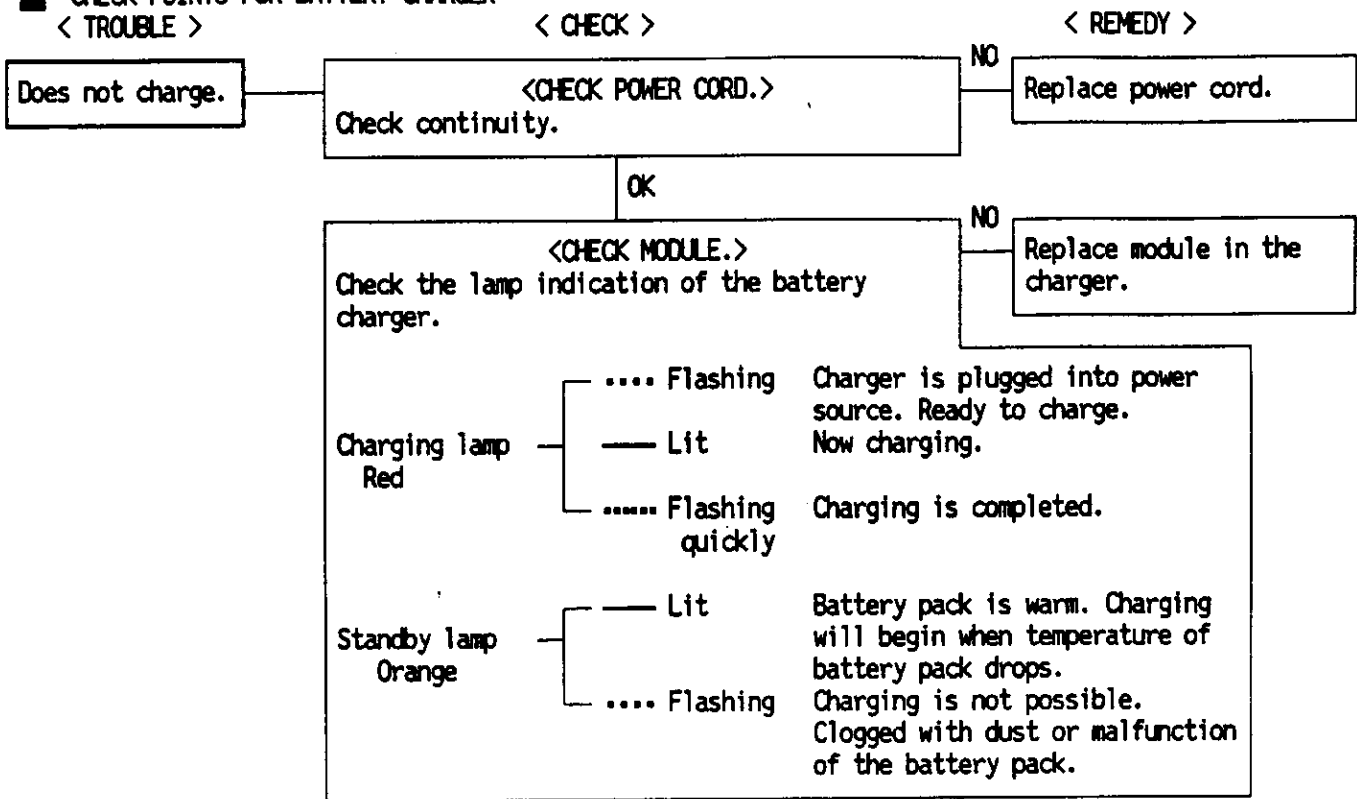
■ CHECK POINTS FOR BATTERY CHARGER
 < TROUBLE >



TRIAL OPERATION (After checking TROUBLESHOOTING GUIDE.)

- ① Check the vibrating operation by setting the clutch handle to , then touching the bit on a board.
 Impact rate per minutes : HIGH 4,050 - 30,000 b.p.m. LOW 1,050 - 8,850 b.p.m.
 Impact strength : 1,670N (170kgf)
- ② Check the clutch operation by setting the clutch handle between 1 - 5.
 clutch torque : 5 steps (approx. 1.0 - 1.5 - 2.5 - 3.4 - 4.4 Nm)
 (approx. 10 - 15 - 25 - 34 - 45 kg-cm)
 ※ There is a possibility that the clutch will not work if it is set to 4 or 5 in the HIGH mode.
- ③ Check the rotation of clutch (without clutch operation) by setting to .
- ④ Check the speed control in proportion to the depression amount of the switch handle.
 LOW : approx. 270 - 2,000 r.p.m.
 HIGH : approx. 70 - 590 r.p.m.
- ⑤ Check the operation by selecting the forward or reverse switch.
- ⑥ Check if the 3 chuck claws open or close smoothly by turning lock handle.
 chuck capacity : ϕ 0.8 - 10 mm
- ⑦ Screwdriver bit locks in place, check if it is locked and can be used as a manual screwdriver.
 torque : max. 22.6Nm (230kgf-cm)

EXPLODED VIEW

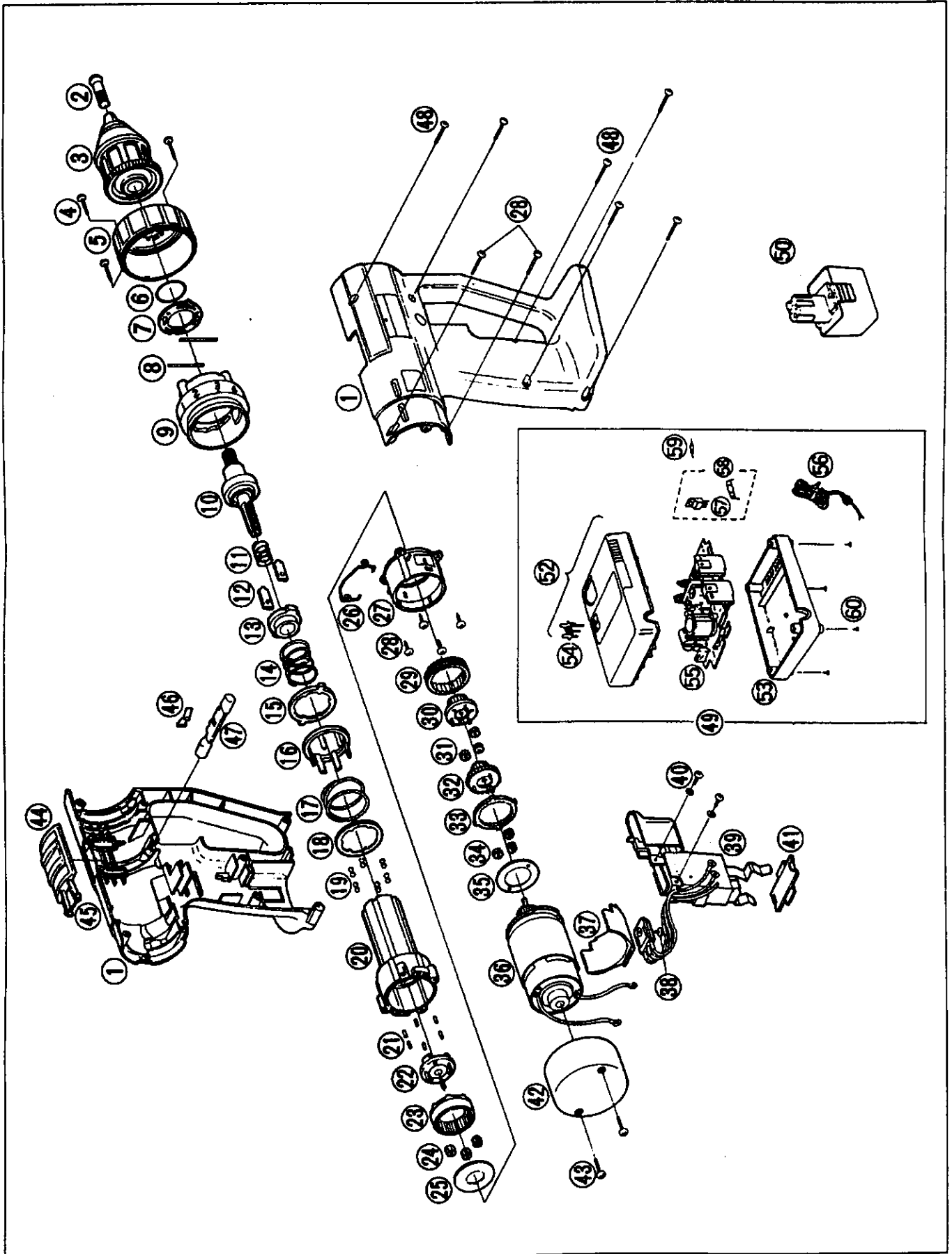

REPLACEMENT PARTS LIST

Note : *A ... available as an optional accessory *C ... available individually
 *B ... only available as set

Ref No.	Parts No.	Parts Name & Descriptions	Per set	Remarks	
▲	1	EY6901K3079	HOUSING AB SET	1	
	2	EY6200B6807	CHUCK FASTENING SCREW	1	
▲	3	EY6901K7918	KEYLESS DRILL CHUCK	1	
	4	EY6901K9067	SCREW	3	*C
	5	EY6901H3227	CLUTCH HANDLE A	1	
	6	EY509B0977	O-RING	1	
	7	EY6901L0567	CHANGE RING	1	
	8	EY6901L0357	PIN	2	*B
	9	EY6901H3258	CLUTCH HANDLE B	1	
	10	EY6901L1137	DRIVING SHAFT	1	
	11	EY6900B0177	SPRING	1	
	12	EY6901L0907	CHANGE PLATE	2	*B
	13	EY6901L1387	CAM A	1	
	14	EY6901L0197	SPRING	1	
	15	EY6901L0457	CLICK PLATE	1	
	16	EY6901L0637	ADJUST RING	1	
	17	EY6901L0167	CLUTCH SPRING	1	
	18	EY6901L0577	CLUTCH PLATE	1	
	19	EY560B6967	STEEL BALL	12	*B
	20	EY6901L1797	CLUTCH CASE	1	
	21	EY6705L0377	ROLLER PIN	6	*B
	22	EY6901L1107	CARRIER	1	
	23	EY6901L1477	RING GEAR	1	
	24	EY6900B1347	PLANET GEAR SET	3	*B
	25	EY6200B0857	THRUST PLATE	1	
	26	EY6207B1517	CHANGE-GEAR SPRING	1	
	27	EY6700B1767	GEAR CASE	1	
	28	EY6705L9637	SCREW	2	*C
	29	EY560B1467	RING GEAR B	1	
	30	EY6900B1107	CARRIER A	1	
	31	EY6200B1357	PLANET GEAR A	3	*B
	32	EY6900B1127	CARRIER B	1	
	33	EY6700B1457	RING GEAR A	1	
	34	EY560B1367	PLANET GEAR B	3	*B
	35	EY6901L0887	THRUST PLATE	1	
▲	36	EY6901L1008	MOTOR	1	
	37	EY6901L2567	RADIATING PLATE	1	
	38	EY6605L9627	TAPPING SCREW	1	
▲	39	EY6901Y2008	SWITCH BLOCK	1	
	40	EY6705K6197	SCREW	2	*C
	41	EY6481L0207	DUST PREVENTIVE PLATE	1	
▲	42	EY6901H3107	HOUSING COVER	1	
	43	EY6901K9387	TAPPING SCREW	2	*C
	44	EY6901H3237	CHANGE-GEAR HANDLE	1	
	45	EY560B0187	SPRING	1	
	46	EY6481L0177	CLICK SPRING	1	
	47	EY6901H3247	FORWARD/REVERSE SELECTOR HANDLE	1	
	48	EY6605K9037	SCREW	6	*C
▲	49	EYD202	BATTERY CHARGER	1	*A
▲	50	EY9001	BATTERY PACK	1	*A
▲	51	EY9591	TOOL CASE	1	

REPLACEMENT PARTS LIST

Ref No.	Parts No.	Parts Name & Descriptions	Per set	Remarks
	52 EY0202B3098	HOUSING A FOR CHARGER	1	
	53 EY0202B3028	HOUSING B FOR CHARGER	1	
	54 EY0200C0547	LAMP COVER	1	
	55 EY0202B2128	MODULE	1	
	56 EY0202B2058	POWER CORD	1	
	57 EY0202B5258	FUSE	1	
	58 EY0202B5028	FUSE & FET SET	1	
	59 EY0202B5098	ZENER DIODE	1	
	60 EY0202B9038	TAPPING SCREW FOR CHARGER	4	*C
▲	- EY6901K8009	INDIVIDUAL BOX	1	
▲	- EY6901K8109	OPERATING INSTRUCTIONS	1	

Free Manuals Download Website

<http://myh66.com>

<http://usermanuals.us>

<http://www.somanuals.com>

<http://www.4manuals.cc>

<http://www.manual-lib.com>

<http://www.404manual.com>

<http://www.luxmanual.com>

<http://aubethermostatmanual.com>

Golf course search by state

<http://golfingnear.com>

Email search by domain

<http://emailbydomain.com>

Auto manuals search

<http://auto.somanuals.com>

TV manuals search

<http://tv.somanuals.com>