

**PAXAR**

***Monarch 415™  
Rewind***

**Operator's Handbook**

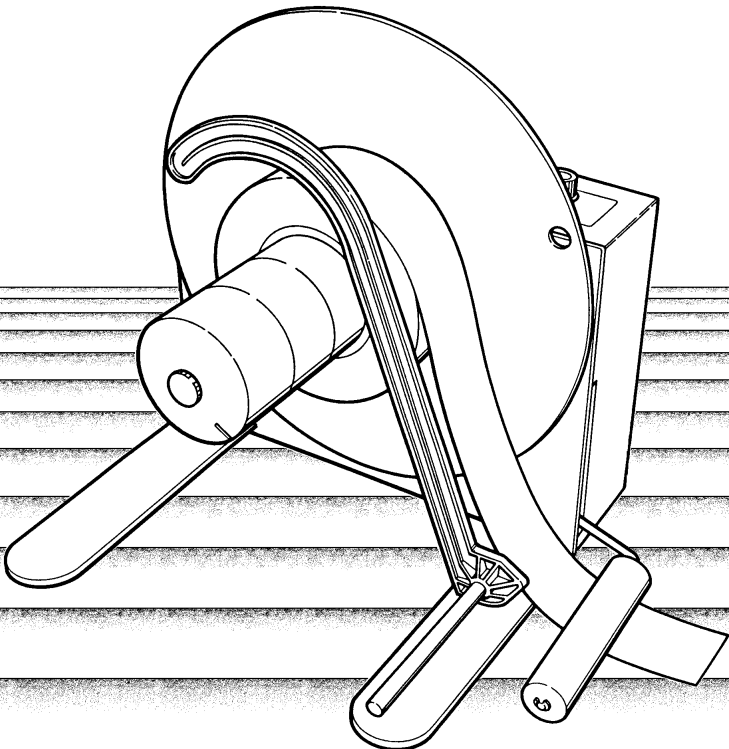

Each product and program carries a respective written warranty, the only warranty on which the customer can rely. Monarch reserves the right to make changes in the product and the programs and their availability at any time and without notice. Although Monarch has made every effort to provide complete and accurate information in this manual, Monarch shall not be liable for any omissions or inaccuracies. Any update will be incorporated in a later edition of this manual.

**Trademarks**

MONARCH is a registered trademark of Monarch Marking Systems, Inc.

415 is a trademark of Monarch Marking Systems, Inc.

Paxar is a trademark of Paxar Corporation.

Monarch Marking Systems

P.O. Box 608

Dayton, Ohio 45401

# Table of Contents

---

<b>1. Setting Up</b> .....	1
<b>2. Connecting Supplies</b> .....	3
Rewinding on the Hub .....	3
Rewinding on a Paper Core .....	5
<b>3. Operating the Rewind</b> .....	7
Starting.....	7
Stopping .....	8
<b>4. Changing Hubs</b> .....	9
<b>5. Burster Option Setup and Operation</b> .....	11
Supply Removal .....	19
<b>6. Specifications and Supplies</b> .....	21
<b>7. Troubleshooting</b> .....	22
<b>Appendix A: Rewind Alignment</b> .....	23



# 1. Setting Up

---

1. Push the 415 Rewind power switch **OFF**.
2. Place the rewind on a level surface. Be sure it is at least ten inches away from the supply exit of the printer (Figure 1).
3. Squarely align the rewind's hub flange with the edge of the supply.

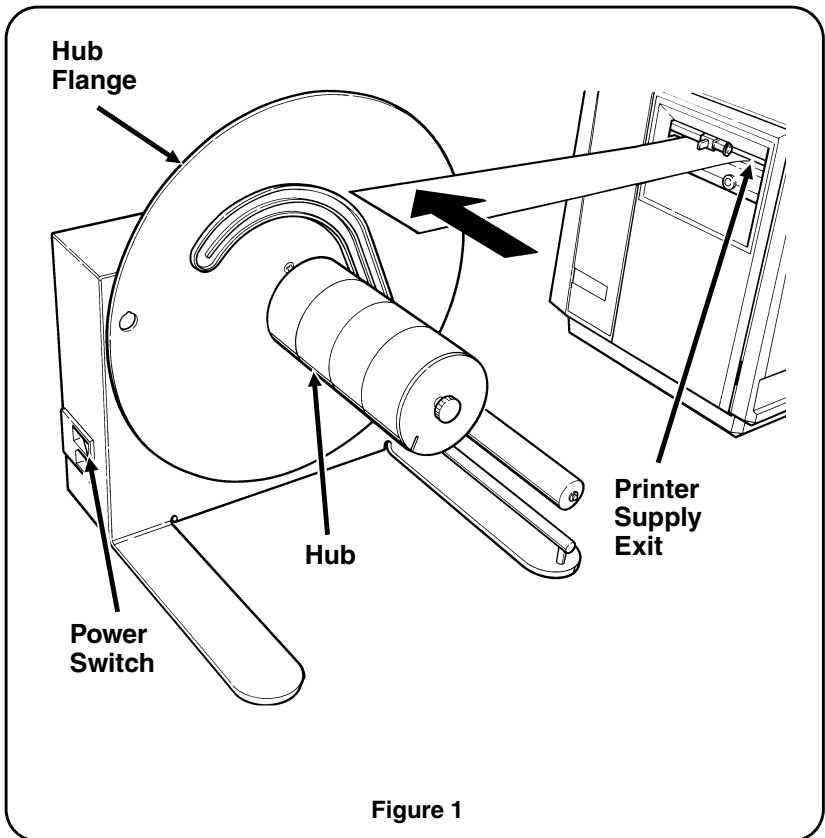

4. Plug the power cord into the rewind (Figure 2). Then, plug the power cord into a grounded electrical outlet.

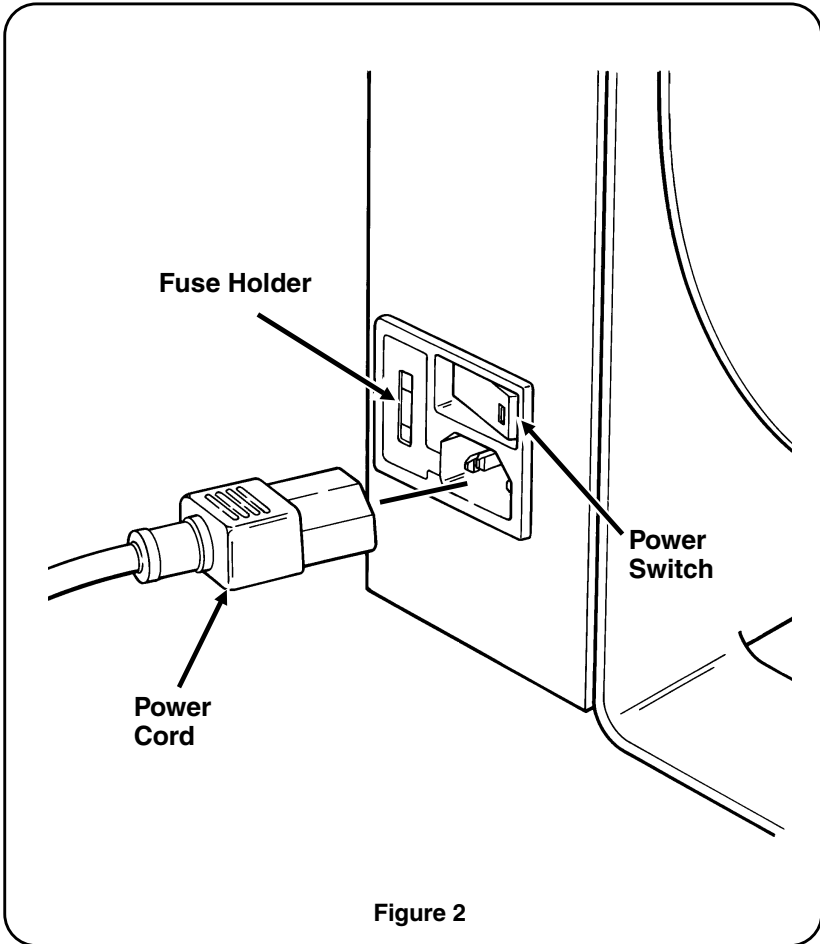

## 2. Connecting Supplies

---

### Rewinding on the Hub

1. Slide the supply guide away from the hub flange and pull it away from the hub.
2. Print or feed enough supplies from the printer to wrap around the hub one and one half times.
3. Hold the hub flange and twist the hub **clockwise** until it stops.
4. Thread the supply strip under the dancer roller.
5. Fold and insert the end of the supply strip into the slot (Figure 3). Be sure the supply is against the hub flange.

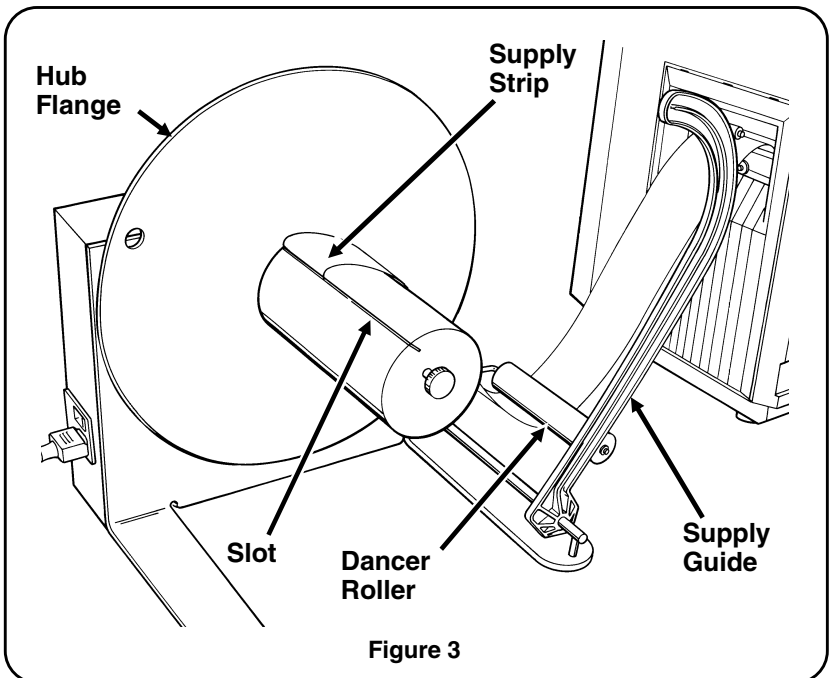

6. Turn the hub and hub flange at least one full turn **counterclockwise** to tighten the supply strip.
7. Push the supply guide against the hub then slide it against the supply.

**NOTE:** Units with 3" hubs have a flanged disk instead of a supply guide.

Slide this disk over the hub and against the stock/core (Figure 4).

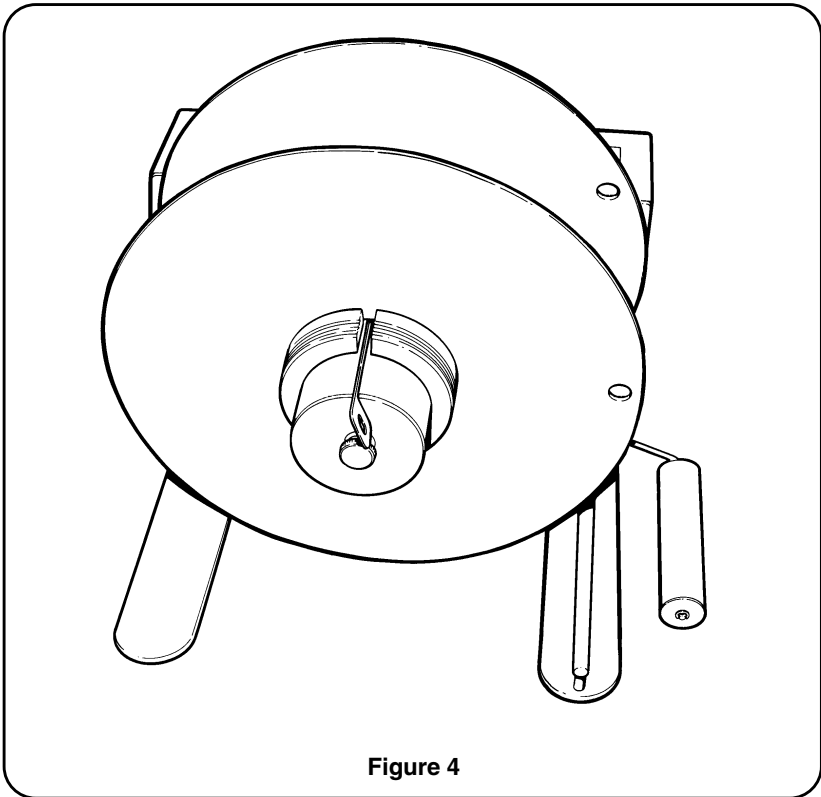
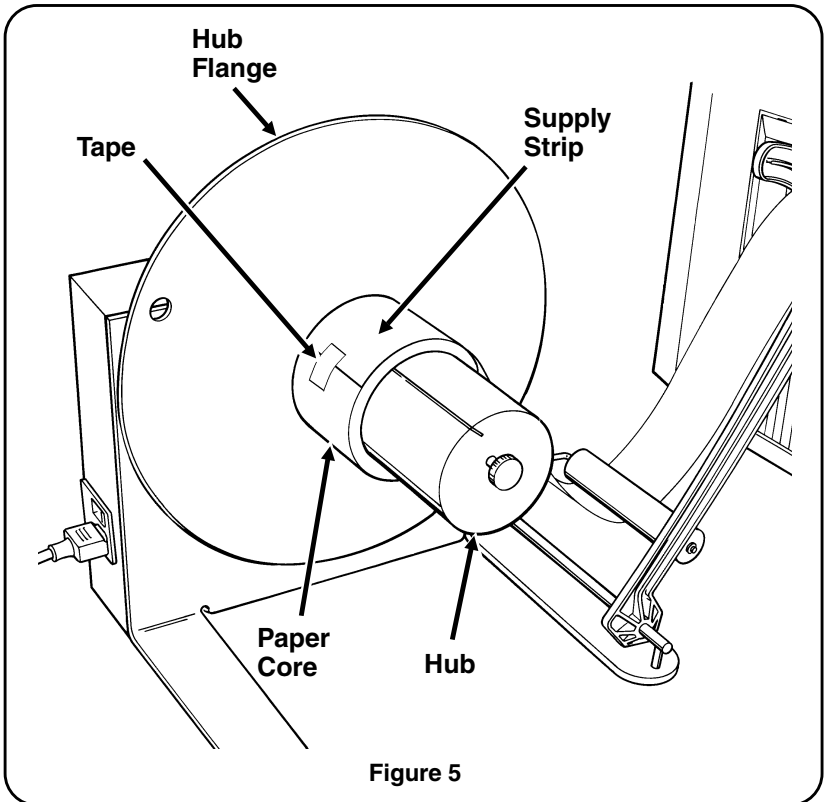

**Figure 4**



## Rewinding on a Paper Core

1. Slide the supply guide away from the hub flange and pull it away from the hub.
2. Push the paper core on the hub until it is against the hub flange.
3. Hold the hub flange and twist the hub **clockwise** until the paper core is tight.
4. Tape the supply strip to the paper core (Figure 5). Be sure the supply is against the hub flange.



5. Turn the hub and hub flange at least one full turn **counterclockwise** to tighten the supply strip.
6. Push the supply guide against the hub then slide it against the supply.

# 3. Operating the Rewind

---

## Starting

1. Turn the speed control knob (Figure 6) to **SLOW**.
2. Push the rewind power switch (Figure 7) **ON**.

**NOTE:** The rewind will start to turn. When the dancer roller is almost horizontal, the rewind will stop.

3. Start the printer.
4. Adjust the rewind speed to the speed of the printer.

**NOTE:** If you stop the printer, the rewind will stop. If the printer runs out of supplies, the rewind will keep running until you turn it off.

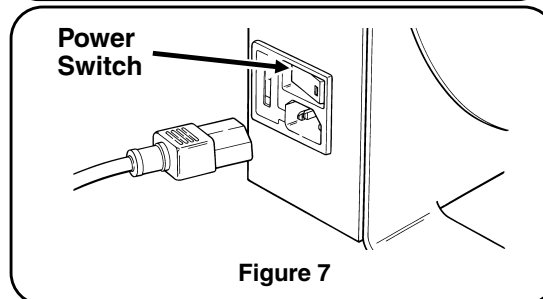
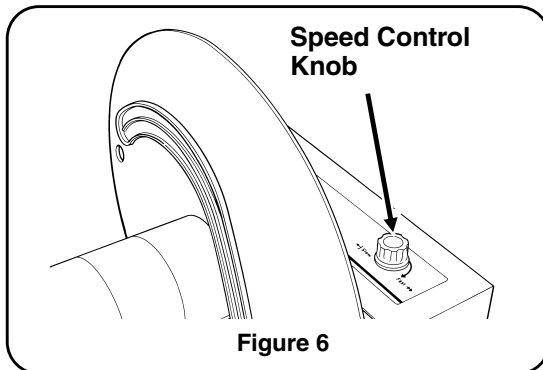

## Stopping

1. Stop the printer.
2. Push the rewind power switch **OFF**.
3. Pull the supply guide away from the hub.
4. Cut the supply at the supply exit of the printer (Figure 8).
5. Tape the end of the supply to the roll on the rewind.
6. Pull the supply guide away from hub.
7. Hold the hub flange and turn the hub **counterclockwise** until the roll is loose.
8. Slide the roll off the hub.

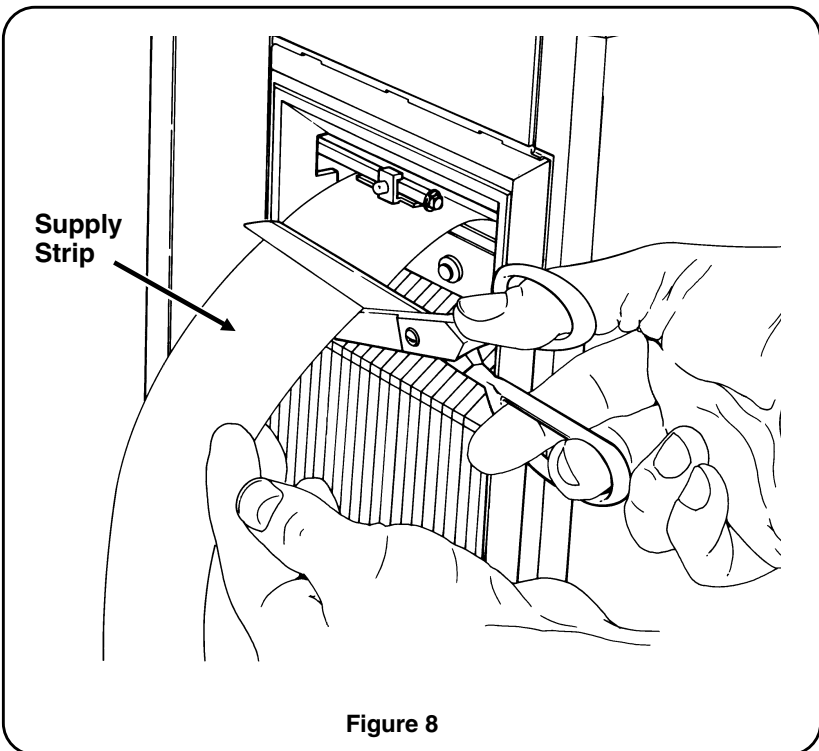

Figure 8

## 4. Changing Hubs

---

If you change to a different supply, you may need to use a different hub. One, three, and four inch diameter hubs (short and long) are available from Monarch.

To change hubs

1. Pull the supply guide away from the hub (Figure 9).

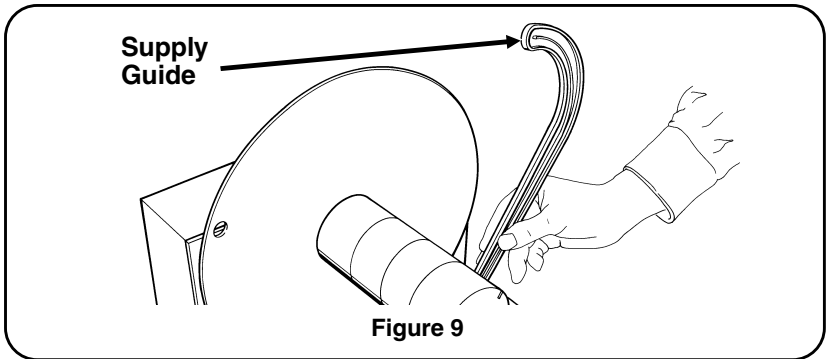

2. Unscrew the hub knob (Figure 10).

**NOTE:** The hub diameter must be the same as the inside diameter of the supplies.

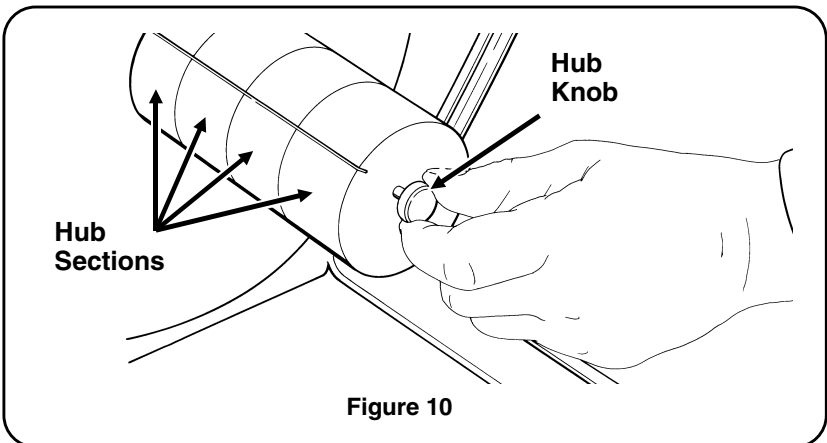

3. Remove the hub sections and replace them with the new ones (Figure 11).
    - a. Slide the new hub spindle on the shaft. Be sure the notch fits over the raised portion of the hub flange.
    - b. Slide the hub sections on to the shaft with the open ends facing out. The hub section that fits against the hub spindle has two curved grooves instead of peg holes. Be sure the slot in this section is aligned with the smaller side of the hub spindle. Also be sure the slots in the rest of the hub sections are aligned with this section.
    - c. Slide the hub end on.
- NOTE:** For a four or six inch long hub, screw on the extension shaft before you install the hub sections.
- d. Screw the hub knob on.

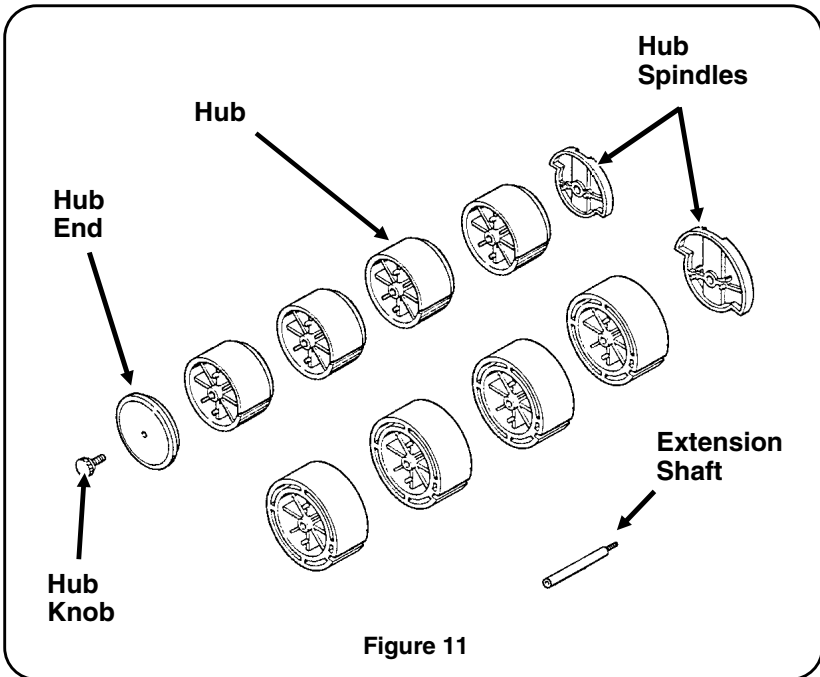

Figure 11

## 5. Burster Option Setup and Operation

---

---

Proper positioning of the printer, burster, and supplies is critical.

1. Place the Rewind/Burster assembly in the proper position in front of the printer. A drawing showing the correct position for all supported printers and optional location guides for alignment is inside the back cover.
2. Print or feed approximately 36 inches of labels from the printer.
3. Bend and separate the supply along the perforations into individual strips for about 18 inches (Figure 12).

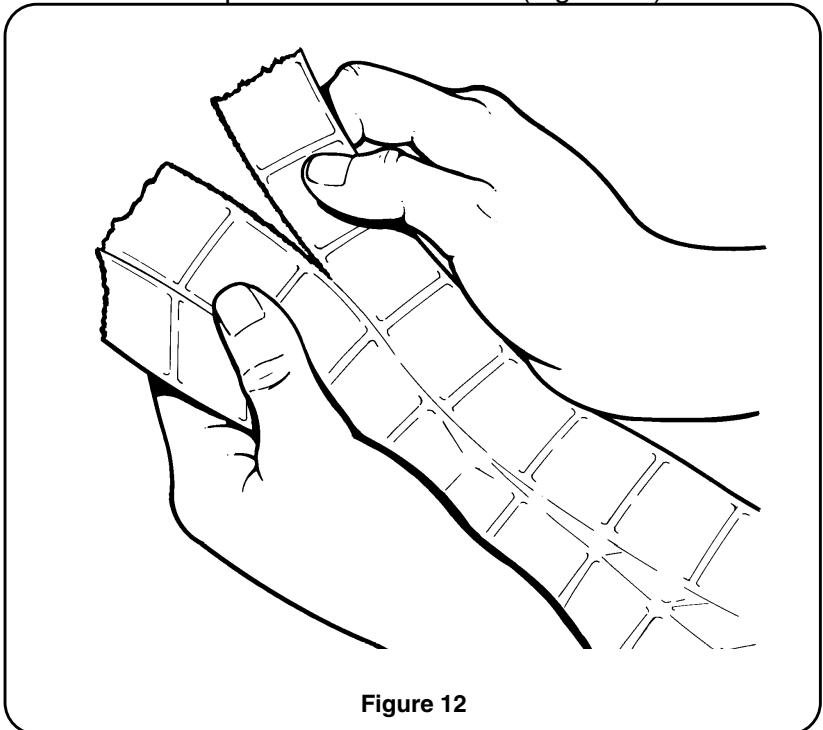
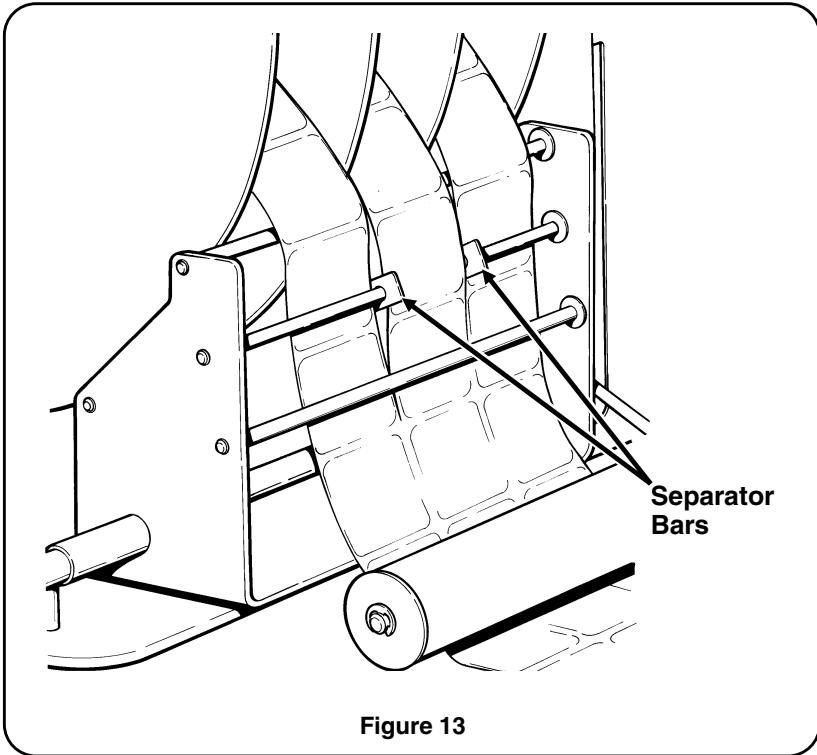

Figure 12

4. Figure 13 shows the burster with the supplies installed. Place the separator bars in their approximate working positions (i.e. in line with the perforations). When only one bar is needed (for two part supply), slide unused bar to the outboard side.



5. Thread the inner strip of supplies under the dancer arm roller, behind the two lower burster shafts, and in front of the top shaft.
6. Thread the middle strip under the dancer arm roller, behind the lower burster shaft, and in front of the two top shafts.
7. Thread the outer strip under the dancer arm roller, behind the two lower burster shafts, and in front of the top shaft.



8. Slide the first core onto the 415 hub until it is against the hub flange.
9. Hold the hub flange and twist the hub clockwise until the paper core is tight.
10. Position the slot in the hub to the top.
11. Align the leading edge of the first label on the inside strip with the slot in the hub and tape the supply to the core (Figure 14).

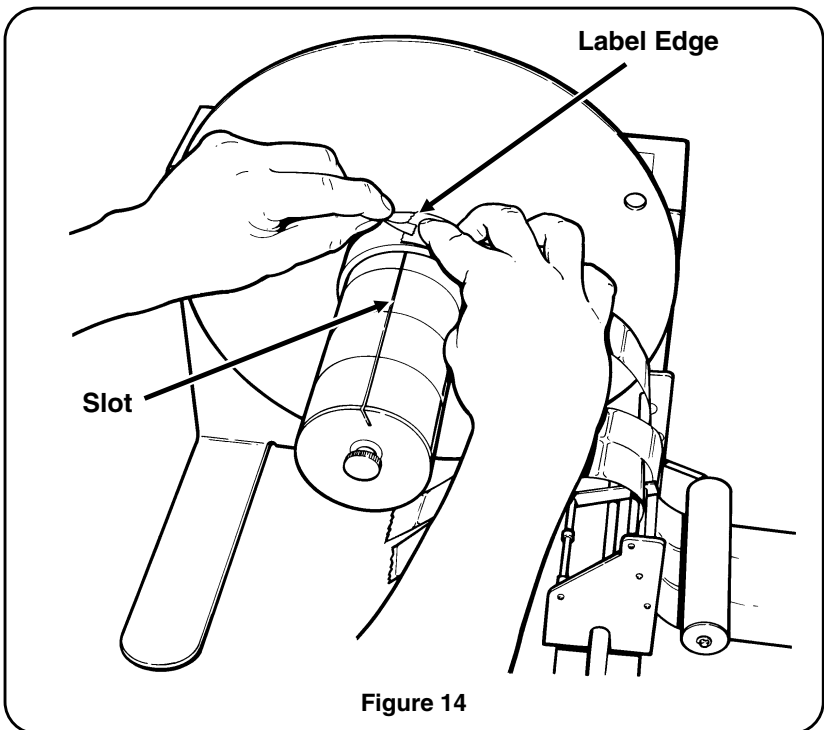

12. Slide the separator disk and the next core onto the hub (Figure 15).
13. Hold the core against the separator disk, insert the core lock (metal strip) into the slot, and slide it into the core.
14. Align the leading edge of the first label on the middle strip with the slot in the hub and tape the supply to the core.

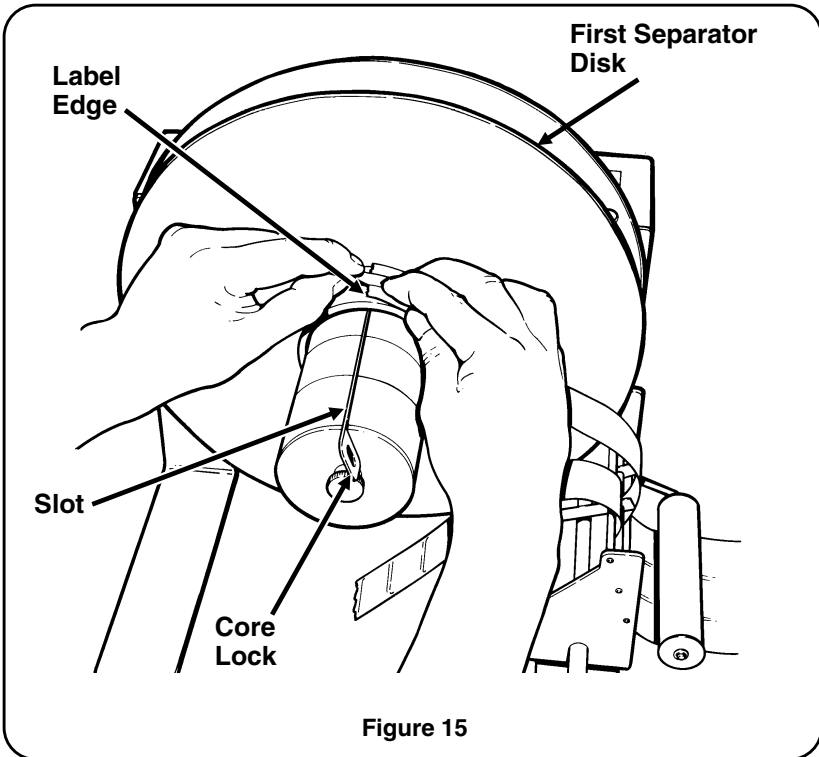

15. Hold the second separator disk with the inside notch up (in line with the core lock) and slide it onto the hub (Figure 16).
16. Place the third core over the core lock and slide it onto the hub.

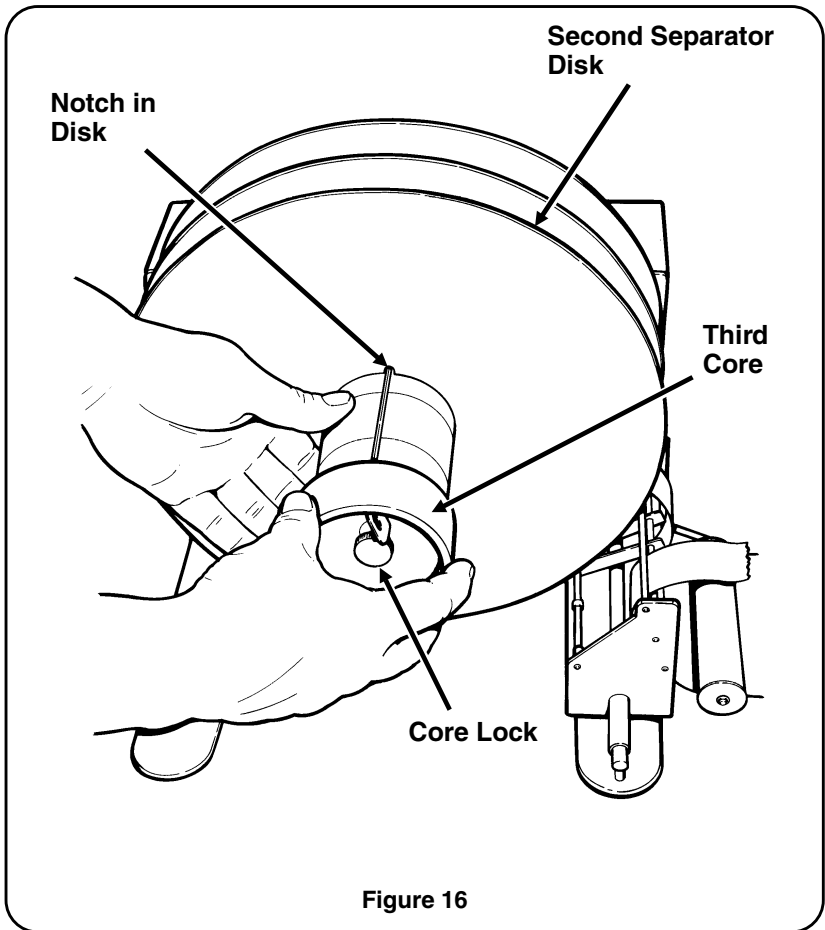

17. Slide the third core against the second separator disk (Figure 17).
18. Align the leading edge of the first label on the outside strip with the slot in the hub and tape the supply to the core.

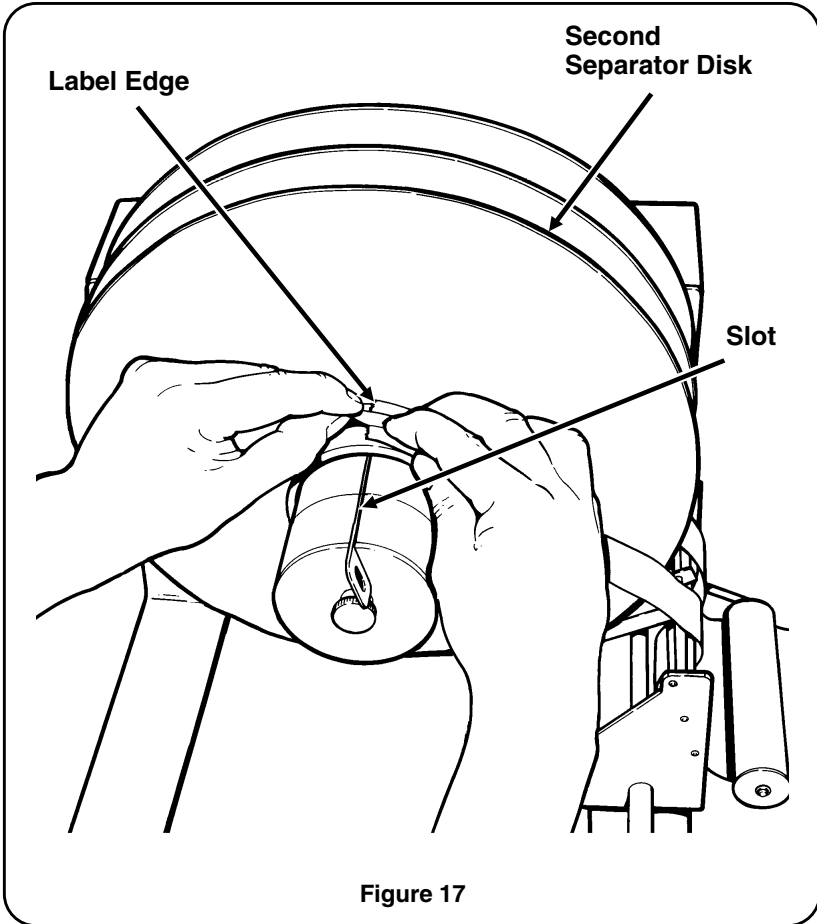

19. Hold the flanged collar assembly with the opening in the collar up. Then install it on the hub as shown in Figure 18.

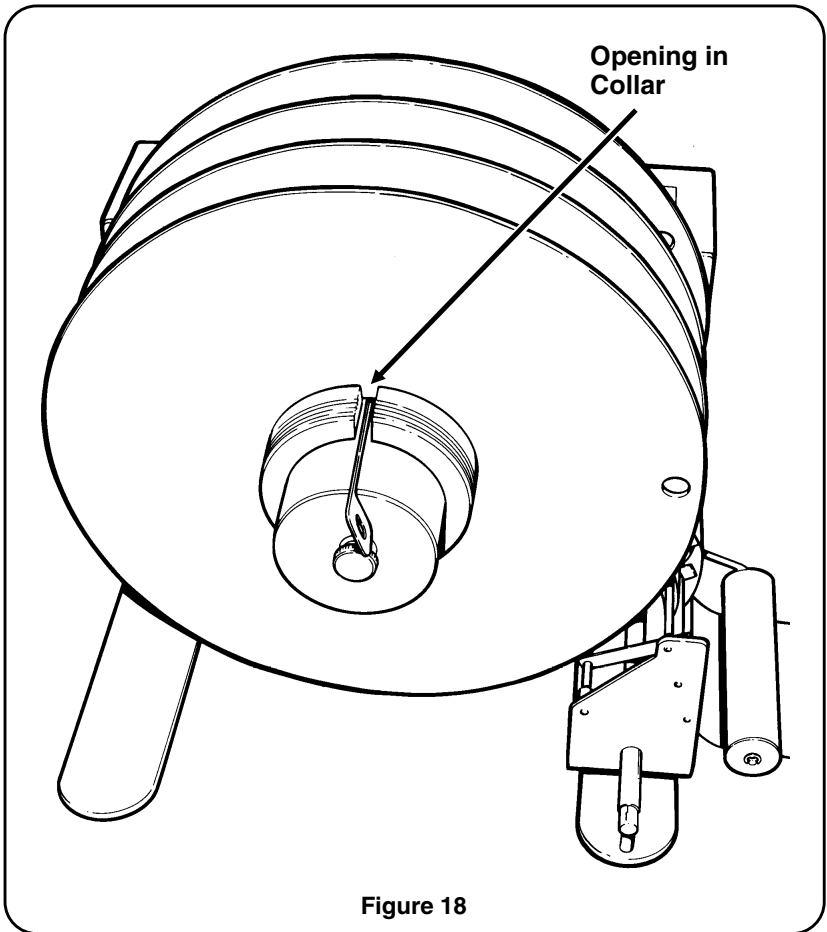
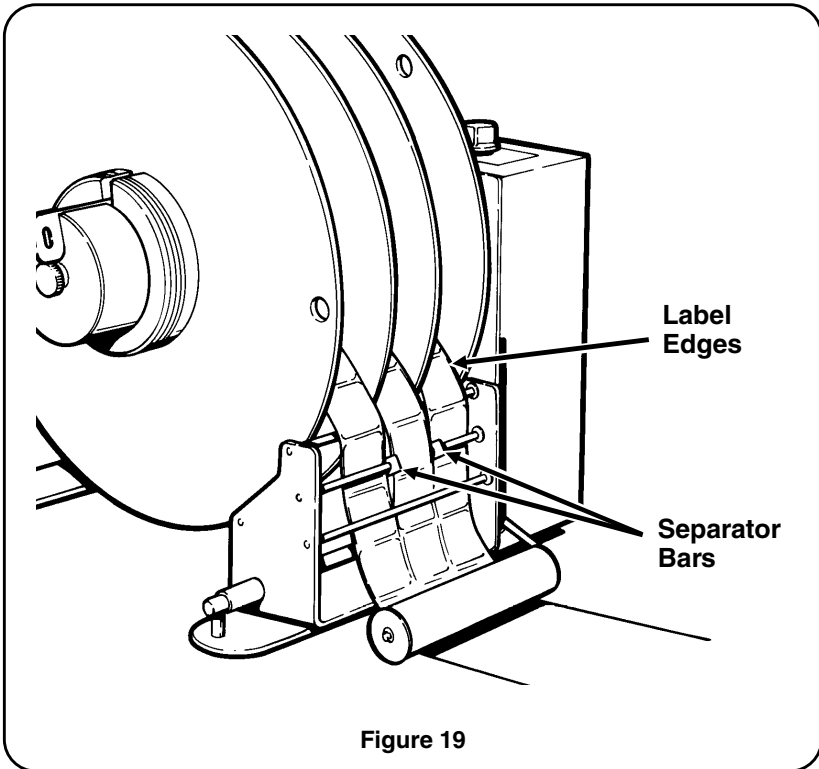

Figure 18

20. Recheck the printer to rewind alignment and fine adjust as necessary.
21. Verify that the separator bars are located between the strip as shown in Figure 19.
22. Verify that the labels on all three strips are aligned.

**NOTE:** All labels must be aligned as though the supply was never separated to prevent torn strips or labels coming off.



23. Turn the flange counterclockwise to take up any slack in the strips.
24. Set the speed control knob to SLOW.
25. Turn on the rewind, operate the printer, and increase the speed if necessary.

## **Supply Removal**

1. Remove the core lock (metal strip).
2. Remove the flanged collar assembly.
3. Remove the outside core and roll of labels.
4. Remove the second separator disk.
5. Remove the middle core and roll of labels.
6. Remove the inside separator disk.
7. Unlock the inside core.
8. Remove the inside core and roll of labels





## 6. Specifications and Supplies

<b>Specifications</b>	
Height: Width: Depth:	13.75 inches (349.25 mm) 12.50 inches (317.5 mm) 11.5 inches (292.10 mm)
Weight:	18 lbs. (8.14 kg)
Shipping Weight:	20 lbs. (9.05 kg)
Power:	115 VAC 60 HZ 30 Watts .3 Amps 220/240 50/60 HZ 30 Watts .15 Amps
Fuse:	3/8 Amp
Temperature:	Operating: 50° to 95° F (10° to 35° C) Storage: 15° to 120° F (-9° to 49° C)
Relative Humidity:	Operating: 10 to 80% Storage: 5 to 90%
Hub Diameter: (Options)	1 inch (25 mm) 3 inch (76 mm) 4 inch (102 mm)
Hub Lengths:	3.62 inch (91.9 mm) 6.75 inch (171.5 mm)

<b>Supplies</b>	
Supply Thickness Tags or Labels:	Minimum: .007 inches (.17 mm) Maximum: .015 inches (.4 mm)
Supply Width:	
3.62 inch shaft (91.9 mm)	Minimum: .75 inches (19.05 mm) Maximum: 3.37 inches (85.6 mm)
6.75 inch shaft (171.5 mm)	Minimum: .75 inches (19.05 mm) Maximum: 6.5 inches (165 mm)

# 7. Troubleshooting

---

<b>Problem</b>	<b>Corrective Action</b>
Power switch light does not light.	Connect the power cord.
	Call Monarch Service.
Dancer arm does not activate the rewind.	Make sure the rewind is on a level surface.

# Appendix A: Rewind Alignment

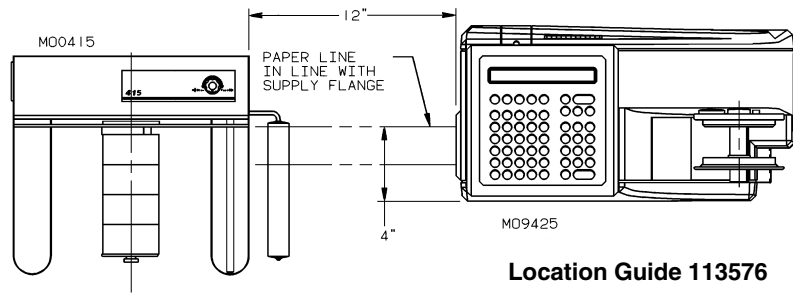

**Location Guide 113576**

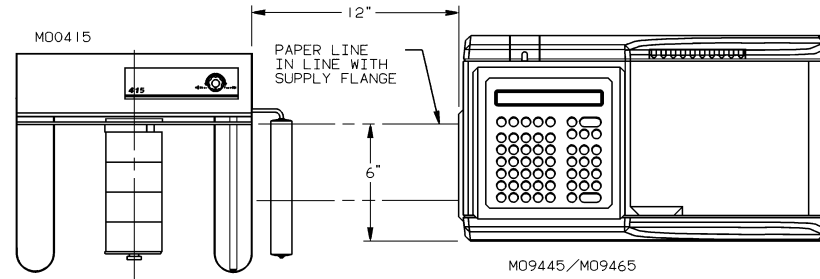

**Location Guide 113576**

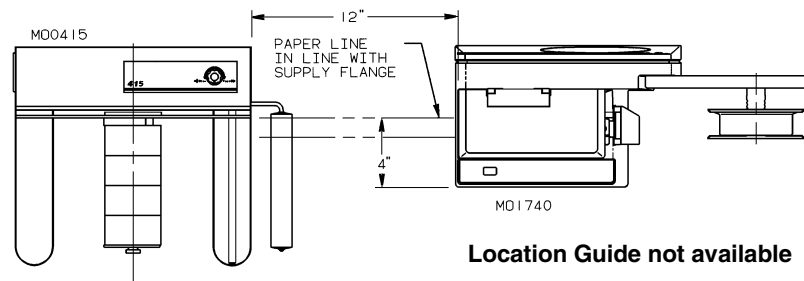

**Location Guide not available**

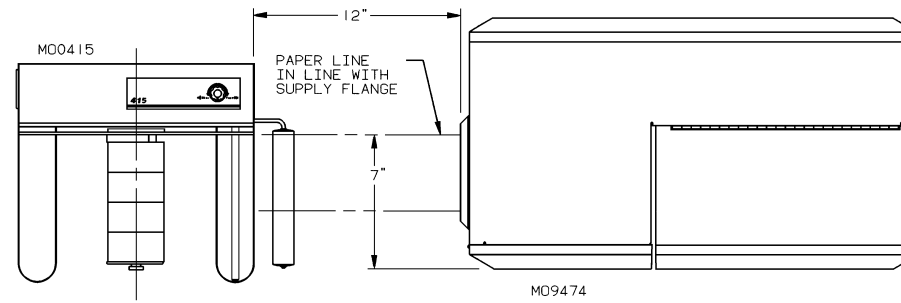

**Location Guide 113576**

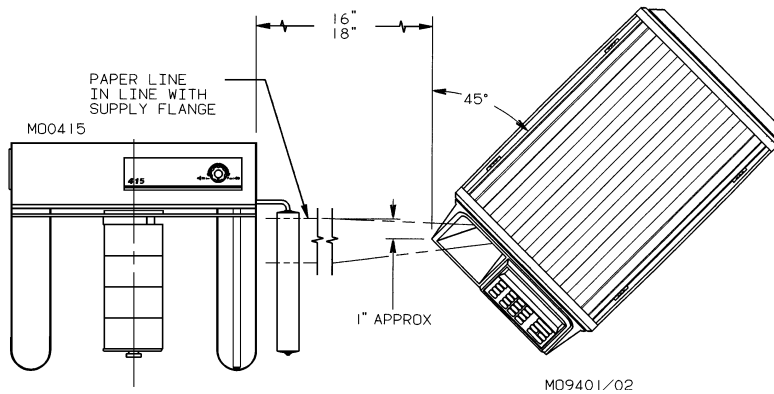

**Location Guide 113580**

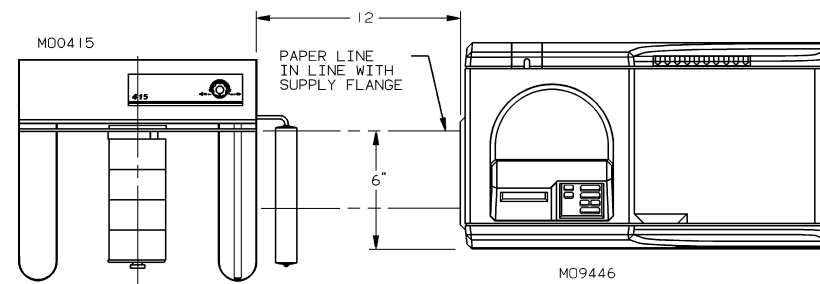

**Location Guide 113576**

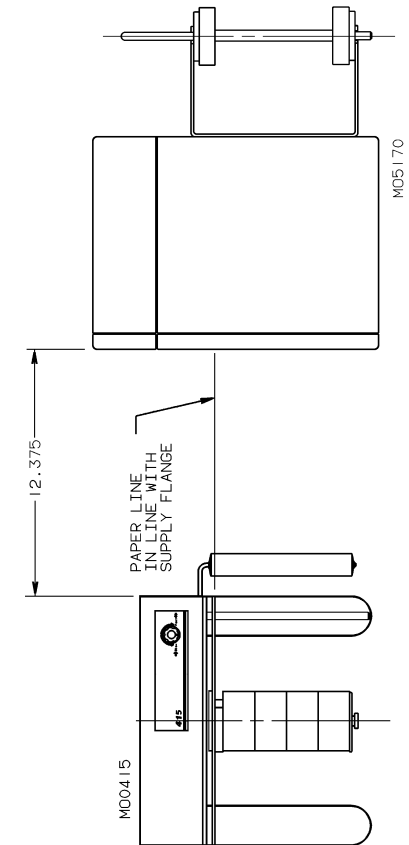

**Location Guide 114664**

For supplies, service, or assistance call:

**TOLL FREE:**

**1-800-543-6650 (In the U.S.A.)**

**1-800-263-4650 (In Canada)**

**[www.paxar.com](http://www.paxar.com)**

## Free Manuals Download Website

<http://myh66.com>

<http://usermanuals.us>

<http://www.somanuals.com>

<http://www.4manuals.cc>

<http://www.manual-lib.com>

<http://www.404manual.com>

<http://www.luxmanual.com>

<http://aubethermostatmanual.com>

Golf course search by state

<http://golfingnear.com>

Email search by domain

<http://emailbydomain.com>

Auto manuals search

<http://auto.somanuals.com>

TV manuals search

<http://tv.somanuals.com>