



Description

Designed for permanent professional installation in schools, churches, theaters, auditoriums, gyms, night clubs, offices and theme parks, the SSE UB2T is a quarter-spherical coverage array providing mid/high frequency coverage of an entire small room, or under a balcony or other barrier spot/delay coverage.

Constructed of premium plywood for strength, rigidity and light weight, the SSE

UB2T has a perforated metal grille covered with cloth for a subtle appearance. Built-in hanging points provide stability and flexibility in coverage adjustment.

This mid/high frequency quarter-spherical array is comprised of four 2" neodymium speakers, with wide dispersion and a very smooth response across their operating band. When mated with a companion woofer module, this combination provides

a clear, smooth full-range sound from a hung system. Input to the array is via barrier strip screw terminals. A built-in 70V/100V transformer with switch-selectable taps and an 8-ohm input option provide maximum flexibility for installations. A separately available active crossover with equalization assures smooth, even frequency response across the operating band.

Features

- Uniquely angled speakers provide wide, even response
- Dual-orientation design for more defined coverage
- Built-in 70V/100V transformer
- Switch selected taps at 30W, 15W, 7.5W, 3.7W, 1.8W and 8 ohms
- 180° by 90° pattern covers a small room or space
- Designed for placement at the ceiling/wall junction or under-balcony locations
- Whole-room mid/high frequency coverage from one enclosure
- Small size makes it unobtrusive
- Processor-based crossover and EQ for maximum performance
- Hanging points incorporated
- Available in black and white painted finishes





Frequency Response, 1 meter on-axis, swept-sine in one-fourth space environment:

8 Ohm Input: 160 Hz to 16 kHz (± 3 dB with processing)

Transformer Input: 200 Hz to 16 kHz (+/- 3 dB with processing)

Usable Low Frequency Limit (-10 dB point one fourth space):

8 Ohm Input: 110 Hz (with processing)

Transformer Input: 180 Hz (with processing and crossover)

Power Handling (above 200 Hz):

8 Ohm Input: 50W continuous
100W program
200W peak

Transformer Input: 30W continuous
60W peak

Sound Pressure Level, 1 watt, 1 meter in anechoic environment:

8 Ohm Input: 90 dB SPL, (2.83 V input)

Maximum Sound Pressure Level (1 meter):

8 Ohm Input: 107 dB SPL continuous
113 dB SPL peak

Transformer Input, 30W tap: 103 dB SPL continuous
106 dB SPL peak

Radiation Angle measured at -6 dB point of polar response:

Operating Into Quarter Space:
Horizontal Dispersion: 180°
Vertical Dispersion: 90°

Operating Into Half Space:
Horizontal Dispersion: 180°
Vertical Dispersion: 110°

Directivity Factor, Ro (Q), 500 Hz – 16 kHz Mean:

Unit has textbook-perfect dispersion of Q = 4 for one-fourth space environment (180° X 90°)

For one-half space environment (180° X 180°), Q = 3.1 +1.0/-1.1

Directivity Index, Di 500 Hz – 16 kHz Mean:

Unit has textbook-perfect dispersion of Di = 6 dB for one-fourth space environment (180° X 90°)

For one-half space environment (180° X 180°), Di = 4.8 dB, +1.2dB/-1.8 dB

Transducer Complement:

Four wide-band neodymium 2" speakers with 1" voice coil

Harmonic Distortion:

8 Ohm In:

1% rated power (or 1W)

2nd Harmonic:
200 Hz: 0.51%
1 kHz: 0.1%

3rd Harmonic:
200 Hz: .42%
1 kHz: 0.1%

10% rated power

2nd Harmonic:
200 Hz: 0.91%
1 kHz: 0.1%

3rd Harmonic:
200 Hz: 2.12%
1 kHz: 0.32%

Transformer Input: Less than 3% up to rated power of 30W and above 200 Hz, typically less than 1%.

Recommended Active Crossover Frequency Region and Slope:

Low Frequency - High Frequency:
200 Hz at 24 dB/octave

Impedance (Z):

8 Ohm Input:
Nominal: 8W
Minimum: 7.2W

Input Connections:

Barrier strip screw terminals

Input Selection Switch:

Selects between 30W, 15W, 7.5W, 3.7W, 1.8W or 8 Ohms Input

NOTE: 30W tap is for 70V input use ONLY!
100V input uses next tap down, e.g., with 100V input, use the 15W tap for 30W output, the 7.5W tap for 15W output, etc.

Use of the nominally 70V 30W tap on 100V will exceed the transformer and system power rating, and will result in failure of the speaker system.

Enclosure Materials & Finish:

Premium plywood finished in black or white paint

Mounting Provisions:

Flying point for suspension, bracket included.

Overall Dimensions (H x W x D):

3.23" x 13.78" x 6.12"
82 mm x 350 mm x 155 mm

Net Weight:

5 lbs. (2.3 kg)

Frequency Response

This measurement is useful in determining how accurately a given unit reproduces an input signal. The frequency response of the SSE™ UB2T is measured at a distance of 1 meter using a 1 watt (into the nominal impedance) swept-sine input signal. As shown in figure 1, the selected drivers in the SSE UB2T combine with the signal processing to give a smooth frequency response from 160 Hz to 16 kHz .

Directivity

Beamwidth is derived from the -6 dB points from the polar plots (see figure 3) which are measured in a whole-space anechoic environment. Q and Directivity Index are plotted for the on-axis measurement position. These are specifications that provide a reference to the coverage characteristics of the unit. These parameters provide insight for proper placement and installation in the chosen environment. The blending of the components of the SSE UB2T exhibits a desirable beamwidth and directivity (figure 3 & 4) suitable for permanent installation applications.

Power Handling

There are many different approaches to power handling ratings. Peavey rates this loudspeaker system's power handling using a full-range form of the AES Standard 2-1984. Using audio band 20 Hz to 20 kHz pink noise with peaks of four times the RMS level, this strenuous test signal assures the user that every portion of this system can withstand today's high technology music. This rating is contingent upon having a minimum of 3 dB of amplifier headroom available.

Harmonic Distortion

Second and third harmonic distortions vs. frequency for the 8-ohm input are plotted in figures 5 & 6 for two power levels. Ten percent (10%) of rated input power and either one percent (1%) of rated input power or one watt, whichever is greater. Distortion is read from the graph as the difference between the fundamental signal (frequency response) and the desired harmonic. As an example, a distortion curve that is down 40 dB from the fundamental is equivalent to 1% distortion.

Mounting

Caution: Before attempting to suspend this speaker, consult a certified structural engineer. Speaker can fall if improperly

suspended, resulting in serious injury and property damage. DO NOT suspend or mount any other product or device from this enclosure. Use only the correct mating hardware. All associated rigging is the responsibility of others. This unit was designed to be hung on the wall or ceiling with the use of a special bracket that fits into the enclosure, via a slot on the rear, and an insert located on the top rear of the cabinet. Use only the supplied bracket.

Architectural & Engineering Specifications

The loudspeaker system shall have an operating bandwidth of 160 Hz to 16 kHz with signal processing, using the 8 ohm input. The nominal output level shall be 90 dB when measured at a distance of one meter with an input of one watt into the 8 ohm input, where the nominal impedance shall be 8 ohms. A 70V/100V distributed line transformer shall be included, with a selector switch to select between transformer taps of: 30W, 15W, 7.5W, 3.7W, 1.8W or to an 8 ohm nominal input. The maximum continuous power handling shall be 50 watts, maximum program power of 100 watts and a peak power input of at least 200 watts, with a minimum amplifier headroom of 3 dB, for the 8 ohm input. The transformer input maximum continuous power handling shall be 30W, with a maximum peak power of 60W, for either a 100V or 70V input line. The nominal radiation geometry shall be 180 degrees in the horizontal plane and 90 degrees in the vertical plane. The overall outside dimensions shall be 3.23 inches high by 13.78 inches wide by 6.12 inches deep. The weight shall be 5 pounds. The mounting/ flying bracket shall be included with the unit. The loudspeaker system shall be a Peavey Sanctuary Series model SSE UB2T.

3 + 2 YEAR LIMITED WARRANTY

NOTE: For details, refer to the warranty statement. Copies of this statement may be obtained by contacting Peavey Electronics Corporation, P.O. Box 2898, Meridian, Mississippi, 39301-2898.

Amplitude Response (1m Equivalent On-Axis)

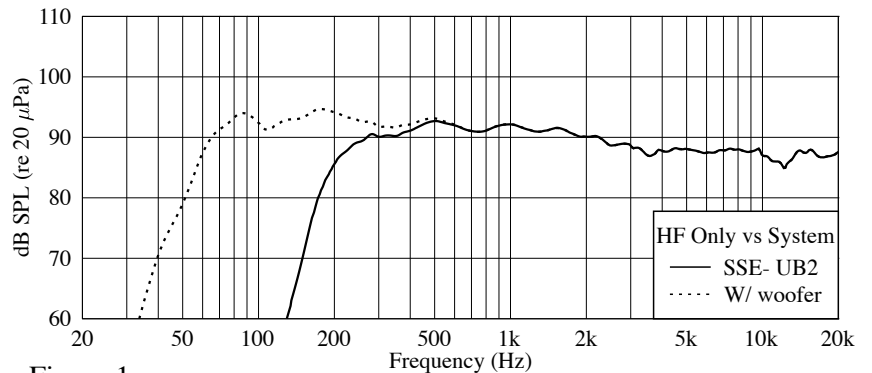

Figure 1

Impedance

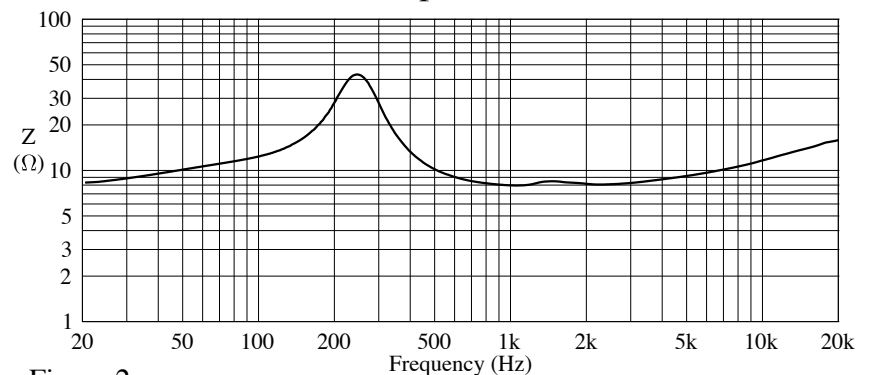

Figure 2

Beamwidth

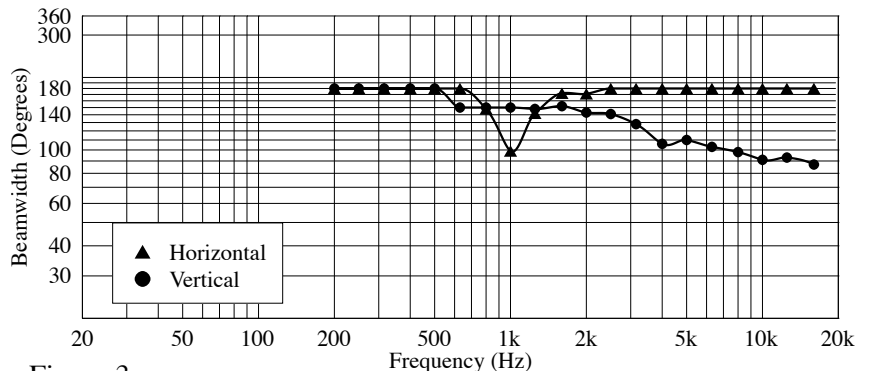

Figure 3



Q & Directivity Index

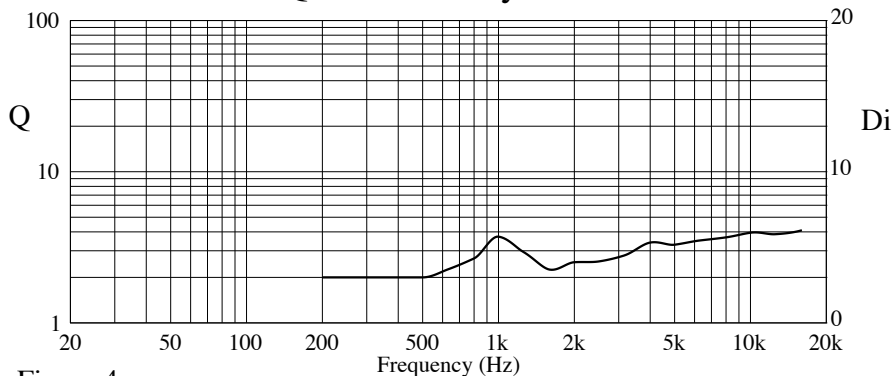

Figure 4

Harmonic Distortion : 1% Rated Power

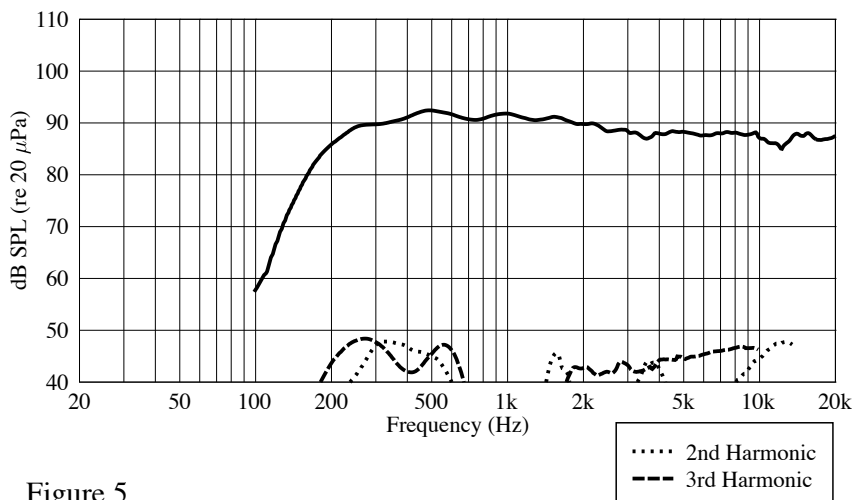

Figure 5

Harmonic Distortion : 10% Rated Power

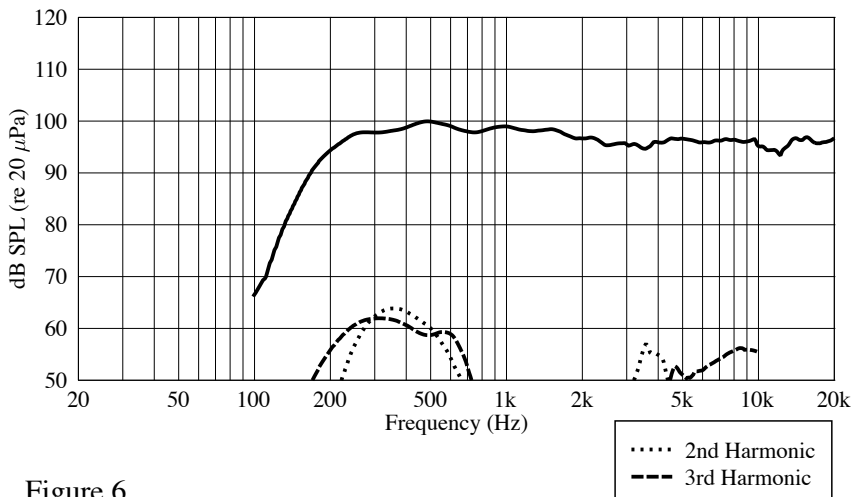
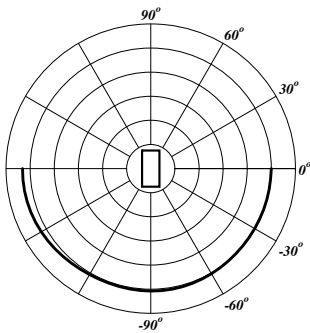

Figure 6

Vertical Polar Plots

1/3 octave averaged plotted on ISO 1/3 octave centers from 200 Hz - 16 kHz.



200 Hz

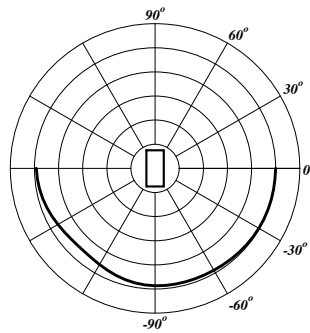

250 Hz

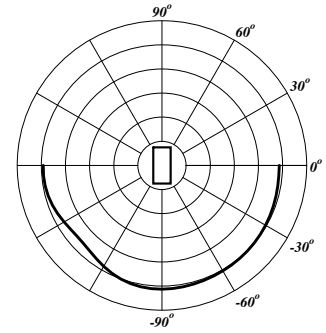

315 Hz

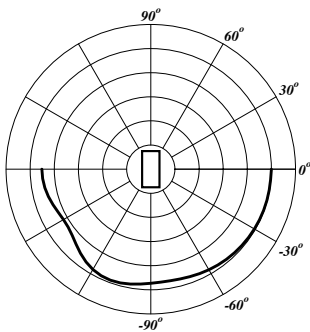

400 Hz

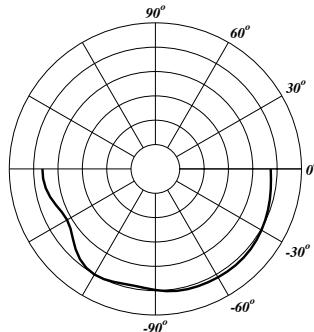

500 Hz

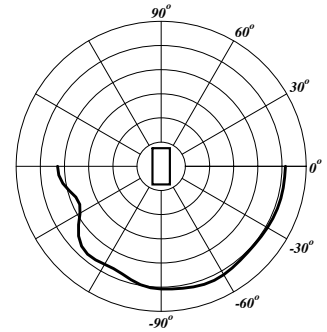

630 Hz

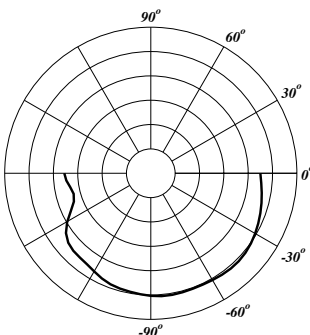

800 Hz

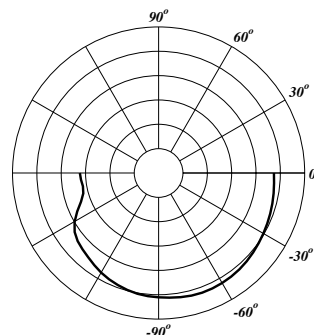

1 kHz

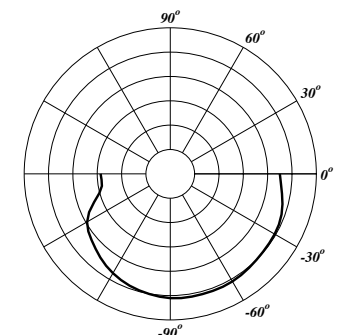

1.25 kHz

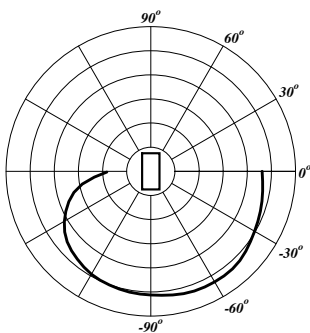

1.6 kHz

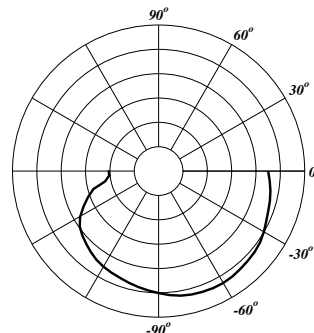

2 kHz

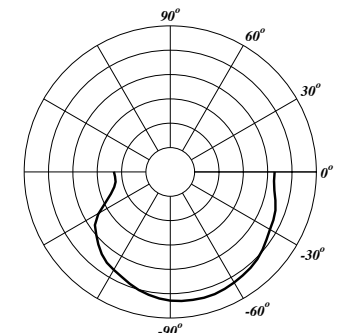

2.5 kHz



SANCTUARY SERIES™

Vertical Polar Plots

1/3 octave averaged plotted on ISO 1/3 octave centers from 200 Hz - 16 kHz.

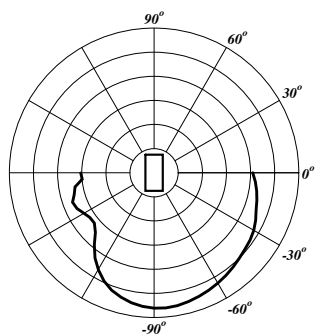

3.15 kHz

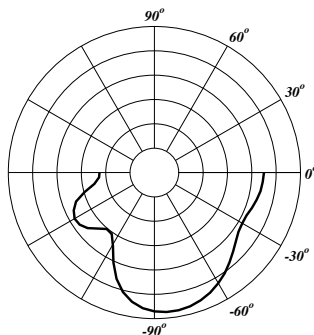

4 kHz

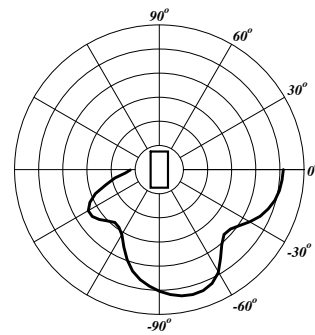

5 kHz

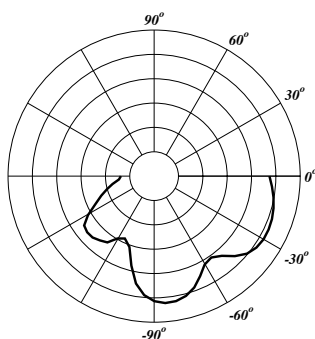

6.3 kHz

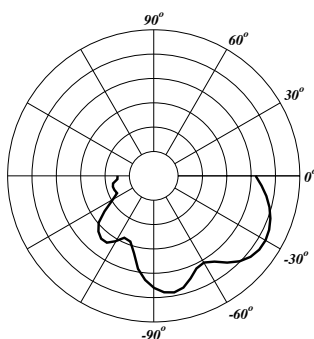

8 kHz

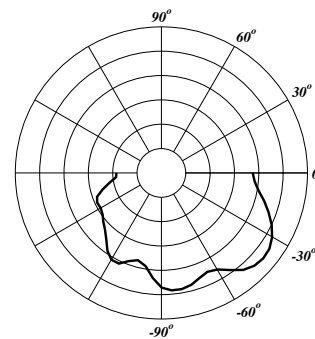

10 kHz

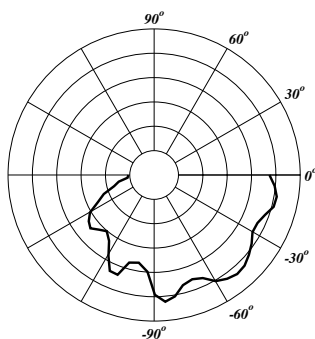

12.5 kHz

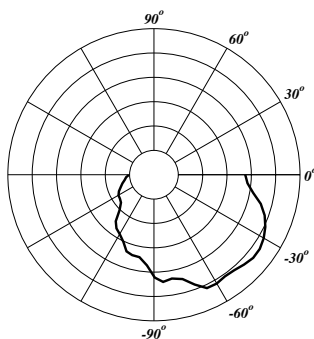

16 kHz

Horizontal Polar Plots

1/3 octave averaged plotted on ISO 1/3 octave centers from 200 Hz - 16 kHz.

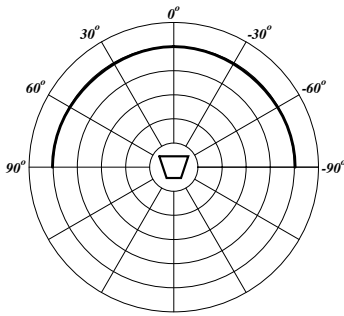

200 Hz

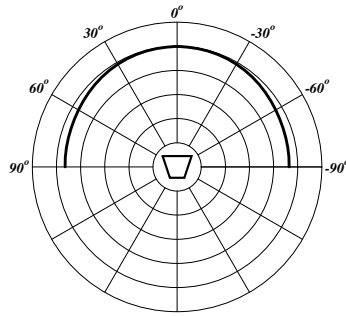

250 Hz

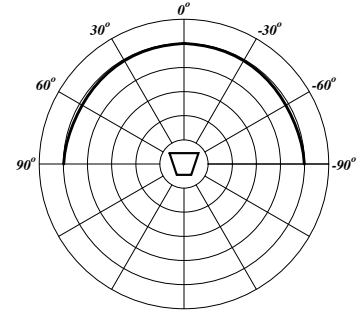

315 Hz

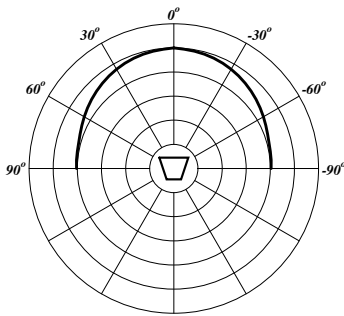

400 Hz

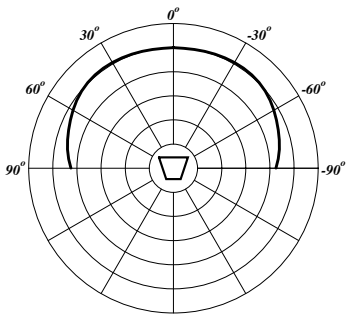

500 Hz

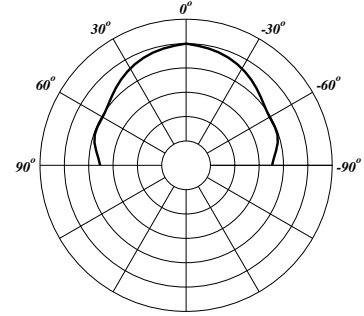

630 Hz

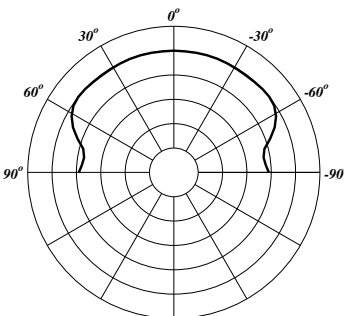

800 Hz

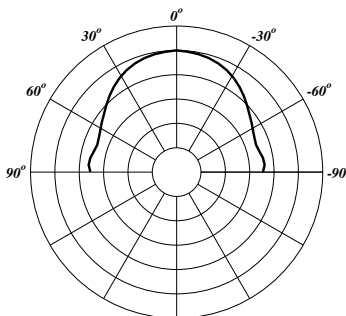

1 kHz

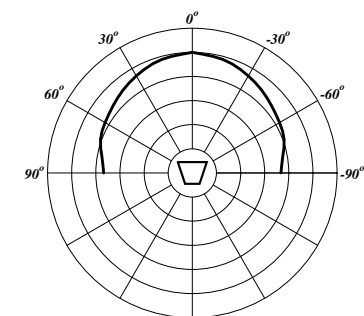

1.25 kHz

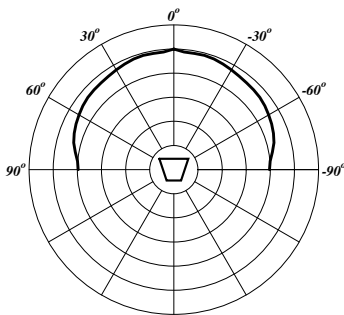

1.6 kHz

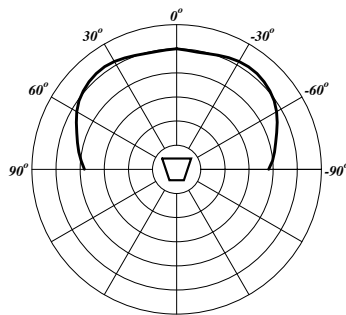

2 kHz

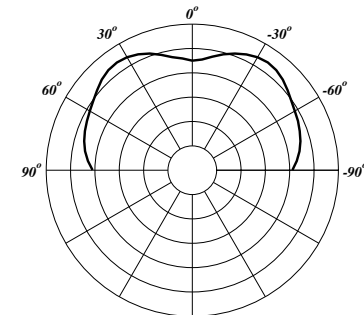

2.5 kHz



SANCTUARY SERIES™

Horizontal Polar Plots

1/3 octave averaged plotted on ISO 1/3 octave centers from 200 Hz - 16 kHz.

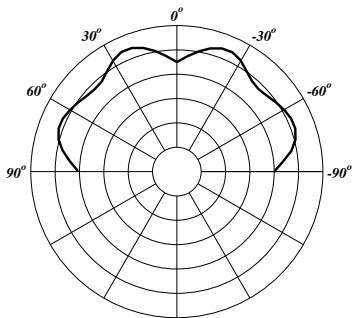

3.15 kHz

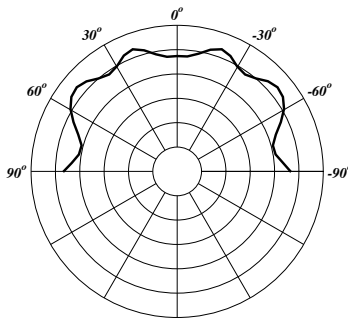

4 kHz

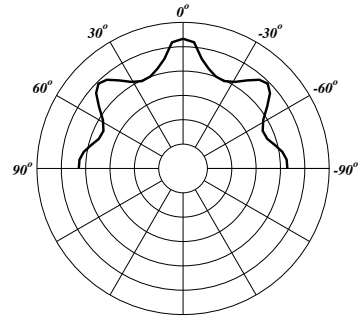

5 kHz

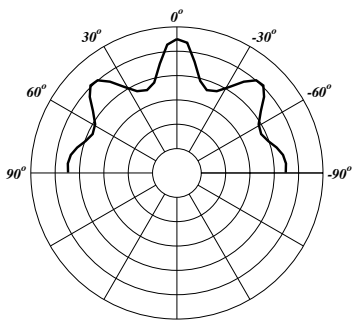

6.3 kHz

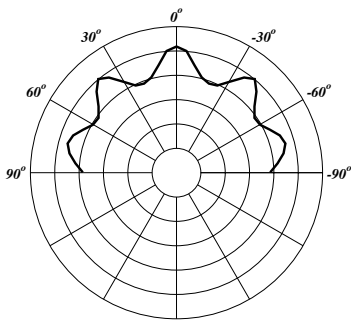

8 kHz

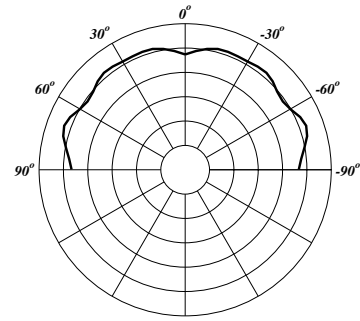

10 kHz

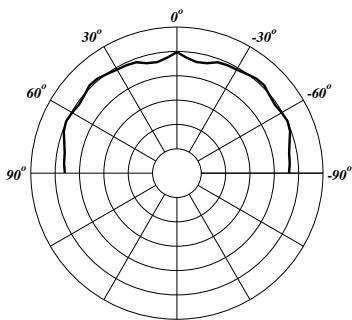

12.5 kHz

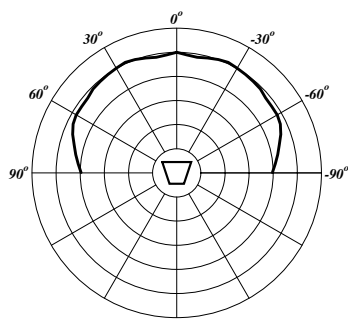

16 kHz

Mounting Instructions:

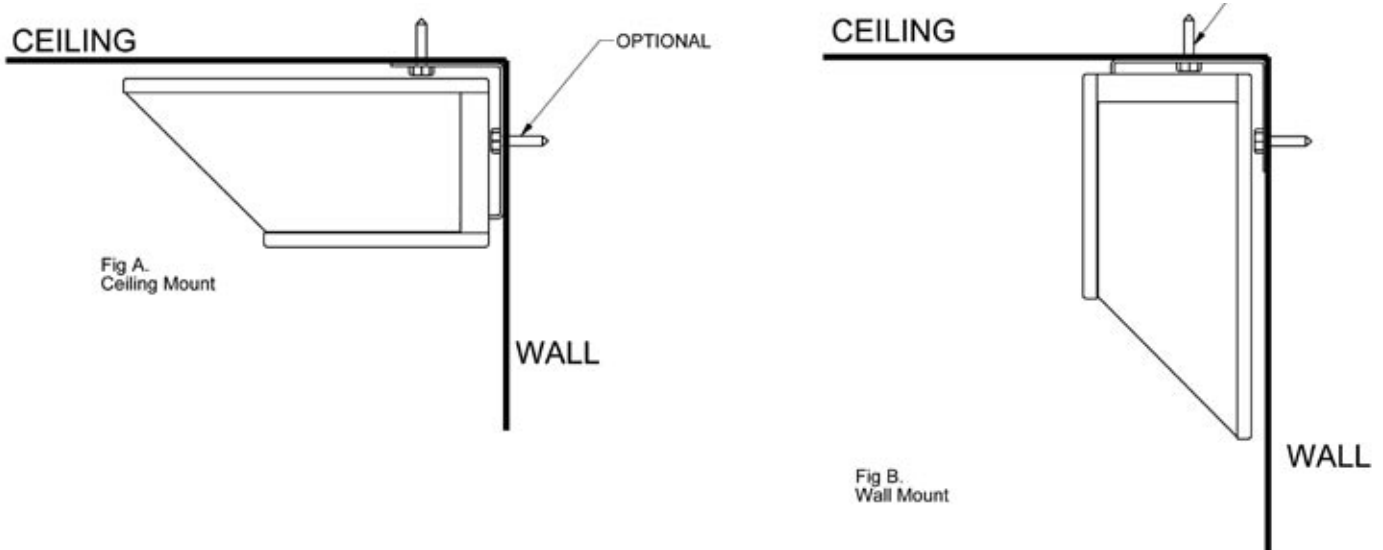

Mounting Instructions:

As a helpful guide to assembling the bracket onto the cabinet for hanging the cabinet on a wall, the following assembly steps are one example of the steps you might take to prepare the bracket and attach the cabinet to a drywall-covered 2x4 stud wall, after consulting with a certified structural engineer.

Remove the bracket from the cabinet by unscrewing the shallow-head bolt from the nominal bottom of the cabinet (small side), noting how the bracket is mated with the slot in the cabinet and saving all the hardware supplied.

Now is a good time to set the input selector to the proper input. Select one of the transformer taps, or the 8 ohm input, since it would otherwise require that the cabinet be dis-mounted from the bracket to change the setting.

Decide where the unit will hang and in which orientation (See Figures A and B). Note that the supplied bracket can have the mounting bolt go through the rear of the bracket or the end opposite of the cabinet slot, so there are two options to allow maximum flexibility in mounting to the ceiling or the wall. With the help of a certified structural engineer, find a wall, ceiling stud or other suitable location and select which hole on the bracket will best interface with that spot. Both mounting

holes can be used in a corner for maximum safety and reliability.

Locate the mounting hole on the selected spot by placing the bracket against the ceiling/wall in the desired pre-selected location. Mark this location by lightly driving a small nail into the wall surface through the correct bracket hole (centered) and then removing the nail. Pre-drill the fastener hole with the proper size drill bit to allow the fastener shaft to enter the stud without splitting it, but not so large as to allow the threads to strip out. Next install the bracket onto the ceiling/wall in the orientation selected, being sure to install it using the appropriate fastener (nominally a 1/4" x 3" lag bolt) into an inner wall or ceiling stud. Never drive a lag bolt into just drywall or just paneling as this will not hold the cabinet safely. Consult a certified structural engineer for all mounting details.

The wall fastener will go through the appropriate bracket hole with a lock washer between it and the bracket. Tighten down this fastener making sure the bracket is oriented as desired. Once the bracket is in place and the fastener has been tightened firmly, connect the cabinet input terminals to the speaker wiring with the wires routed as desired. Place the cabinet onto the bracket in its factory configuration and insert and tighten the shallow-head bracket mounting bolt removed in the first step.

This is just one example of the steps that one might take to install the SSE UB2T by mounting it on a wall or ceiling. Other types of walls/ceilings other than a dry-wall panel and 2x4 stud construction may require different fasteners and steps to safely hang the SSE UB2T. Consult a certified structural engineer to assure that the SSE UB2T will be properly and safely hung under the specific conditions present.

Note that the SSE UB2T is intended to be used with a separate woofer, an electronic crossover and two channels of amplification to provide full-range performance. The SSE UB2T is not a full-range system by itself, and only covers the range from approximately 200 Hz and up. A number of suitable crossover options are available from Peavey: the Peavey Digitool™, the Peavey VSX™ 26 Loudspeaker Controller and the SSE™ Array Controller. The first two units have pre-configured setup files that provide an optimized crossover and EQ for a flat response and level set as a starting place for any permanent installation.

The woofers in the SSE line that mate well with the SSE UB2T are the SSE 210 and the SSE 110. One SSE 110 can provide bass for up to two SSE UB2T cabinets.



SANCTUARY SERIES™

Input Plate:

PEAVEY
SANCTUARY SERIES™
SSE™ -UB2T

MAX POWER:100W PROGRAM
LOW FREQ.LIMIT:200Hz

+

-

INPUT

INPUT TAP SELECTOR

CAUTION! DO NOT USE THIS TAP WITH 100V INPUT!

70V INPUT	100V INPUT	3.7W	7.5W	15W	30W	N/A	8 OHMS
		1.8W	3.7W	7.5W	15W	30W	



SANCTUARY SERIES™

by



www.sanctuary-series.com

Features and specifications subject to change without notice.

Peavey Electronics Corporation 5022 Hartley Peavey Drive Meridian, MS 39305 (601) 483-5365 FAX (601) 486-1278 EX000040 ©2005



Logo referenced in Directive 2002/96/EC Annex IV
(OJ(L)37/38,13.02.03 and defined in EN 50419: 2005
The bar is the symbol for marking of new waste and
is applied only to equipment manufactured after
13 August 2005

Free Manuals Download Website

<http://myh66.com>

<http://usermanuals.us>

<http://www.somanuals.com>

<http://www.4manuals.cc>

<http://www.manual-lib.com>

<http://www.404manual.com>

<http://www.luxmanual.com>

<http://aubethermostatmanual.com>

Golf course search by state

<http://golfingnear.com>

Email search by domain

<http://emailbydomain.com>

Auto manuals search

<http://auto.somanuals.com>

TV manuals search

<http://tv.somanuals.com>