



Midibase™

Operating Guide

PEAVEY®



Intended to alert the user to the presence of uninsulated "dangerous voltage" within the product's enclosure that may be of sufficient magnitude to constitute a risk of electric shock to persons.



Intended to alert the user to the presence of important operating and maintenance (servicing) instructions in the literature accompanying the product.

CAUTION Risks of electrical shock — DO NOT OPEN

CAUTION To reduce the risk of electric shock, do not remove cover. No user serviceable parts inside. Refer Servicing to qualified service personnel.

WARNING To prevent electrical shock or fire hazard, do not expose this appliance to rain or moisture. Before using this appliance, read the operating guide for further warnings.



Este símbolo tiene el propósito de alertar al usuario de la presencia de instrucciones importantes sobre la operación y mantenimiento en la literatura que viene con el producto.



Este símbolo tiene el propósito de alertar al usuario de la presencia de "(voltaje) peligroso" que no tiene aislamiento dentro de la caja del producto que puede tener una magnitud suficiente como para constituir riesgo de corrientazo.

PRECAUCION Riesgo de corrientazo - No abra.

PRECAUCION Para disminuir el riesgo de corrientazo, no abra la cubierta. No hay piezas adentro que el usuario pueda reparar. Deje todo mantenimiento a los técnicos calificados.

ADVERTENCIA Para evitar corrientazos o peligro de incendio, no deje expuesto a la lluvia o humedad este aparato. Antes de usar este aparato, lea más advertencias en la guía de operación.



Ce symbole est utilisé pour indiquer à l'utilisateur qu'il ou qu'elle trouvera d'importantes instructions sur l'utilisation et l'entretien (service) de l'appareil dans la littérature accompagnant le produit.



Ce symbole est utilisé pour indiquer à l'utilisateur la présence à l'intérieur de ce produit de tension non-isolée dangereuse pouvant être d'intensité suffisante pour constituer un risque de choc électrique.

ATTENTION Risques de choc électrique — NE PAS OUVRIR!

ATTENTION Afin de réduire le risque de choc électrique, ne pas enlever le couvercle. Il ne se trouve à l'intérieur aucune pièce pouvant être réparée par l'utilisateur. Confier l'entretien à un personnel qualifié.

AVERTISSEMENT Afin de prévenir les risques de décharge électrique ou de feu, n'exposez pas cet appareil à la pluie ou à l'humidité. Avant d'utiliser cet appareil, lisez les avertissements supplémentaires situés dans le guide d'utilisation.



Dieses Symbol soll den Benutzer auf wichtige Instruktionen in der Bedienungsanleitung aufmerksam machen, die Handhabung und Wartung des Produkts betreffen.



Dieses Symbol soll den Anwender vor unisolierten gefährlichen Spannungen innerhalb des Gehäuses warnen, die von Ausreichender Stärke sind, um einen elektrischen Schlag verursachen zu können.

VORSICHT Risiko - Elektrischer Schlag! Nicht öffnen!

VORSICHT Um das Risiko eines elektrischen Schlages zu vermeiden, nicht die Abdeckung entfernen. Es befinden sich keine Teile darin, die vom Anwender repariert werden könnten. Reparaturen nur von qualifiziertem Fachpersonal durchführen lassen.

ACHTUNG Um einen elektrischen Schlag oder Feuergefahr zu vermeiden, sollte dieses Gerät nicht dem Regen oder Feuchtigkeit ausgesetzt werden. Vor Inbetriebnahme unbedingt die Bedienungsanleitung lesen.

INTRODUCTION

You are now the owner of a PEAVEY MIDIBASE™.

With this technologically advanced instrument, you now have access to the world of MIDI.

The PEAVEY MIDIBASE translates bass guitar playing into MIDI CODE. Using this MIDI CODE, the PEAVEY MIDIBASE can trigger synthesizers, samplers, sequencers, or any other musical instrument or computer that has a MIDI INPUT.

As well as opening the door to the world of MIDI, the MIDIBASE is also a professional bass guitar.

So, you can have the best of both worlds...at the same time.

For example, you can double your regular bass sound with any sound you want: a double bass, a vibraphone, or a sample of a 747 taking off.

The only limit to sound creation is your imagination.

Due to the accurate and quick tracking speed of the MIDIBASE, you will find it exceptionally invaluable in live situations.

We all know how synthesizer bass sounds have dominated music in recent times. You can now access the big synth-y sounds so popular today using your PEAVEY MIDIBASE.

The PEAVEY MIDIBASE not only gives you your gig back, but a lot more besides.

Nothing grooves like a PEAVEY MIDIBASE.

Now you can record these grooves into sequencers. No more "claw" chords or stilted lines. Your artistry translates perfectly into the digital domain.

As well as laying down the bass line, you can "pop" the drums and provide your own percussion, as well as string lines, horn arrangements, etc.

Your ability to access a greater range of tones and textures will be invaluable in writing that next hit single.



1. E STRING MIDI PICKUP
The MIDI pickup that monitors the E STRING.
2. A STRING MIDI PICKUP
The MIDI pickup that monitors the A STRING.
3. D STRING MIDI PICKUP
The MIDI pickup that monitors the D STRING.
4. G STRING MIDI PICKUP
The MIDI pickup that monitors the G STRING.
5. ANALOG PICKUP
As on a standard bass.
6. ANALOG PICKUP
As on a standard bass
7. LED DISPLAY
8. DATA SWITCH
Switch used for adjusting data in the MIDIBASE.
9. MIDI VOLUME CONTROL
Volume control for the synthesizer.
10. REGULAR BASS VOLUME CONTROL
11. ANALOG BALANCE CONTROL
Balances levels of front and back pickups.
12. ANALOG TONE CONTROL
13. MIDIBASE CABLE INPUT JACK
The MIDIBASE cable is plugged in here.
14. 1/4" ANALOG AUDIO OUTPUT JACK
Only used when NOT using MIDI.

SPLITTER RACK FRONT PANEL

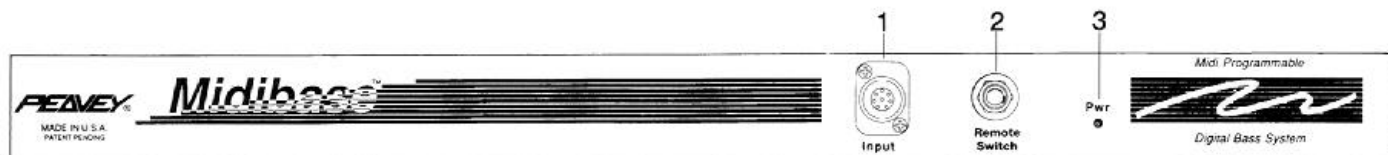

1. MIDIBASE CABLE INPUT JACK
The MIDIBASE guitar is plugged in here.
2. FOOTSWITCH INPUT JACK
3. POWER LED
This red LED shines when power is connected.

SPLITTER RACK BACK PANEL

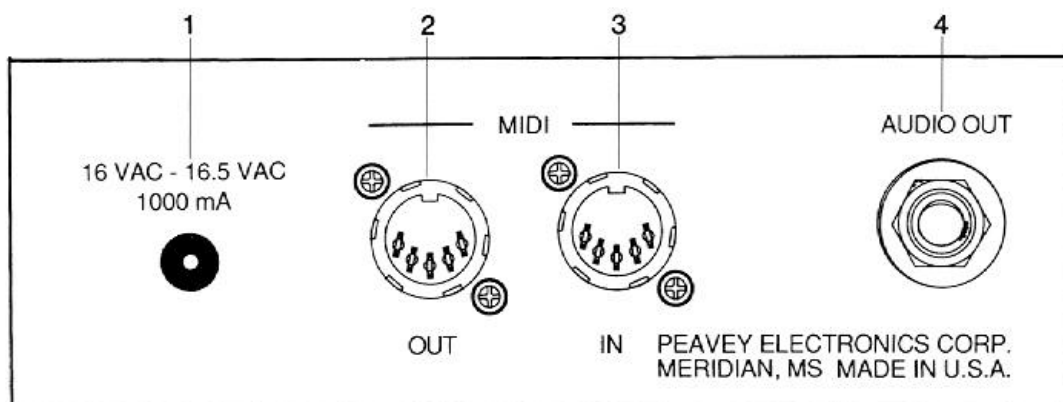

1. AC POWER PACK INPUT
The 16 V AC—16.5 V AC 100 mA power pack is plugged in here.
2. MIDI OUTPUT JACK
Standard 5-pin DIN jack used for sending MIDI data.
3. MIDI INPUT JACK
Standard 5-pin DIN jack used for receiving MIDI data.
4. 1/4" AUDIO OUTPUT JACK
The analog audio is available from this jack.

MIDI Pickups

When your PEAVEY MIDIBASE leaves the factory, the MIDI PICKUPS are preset to the correct adjustment.

However, if you decide to change the action on your PEAVEY MIDIBASE, the MIDI PICKUPS will have to be reset. (See Page 23 "MIDI PICKUP ADJUSTMENTS.")

If the MIDI PICKUPS are not adjusted correctly, the PEAVEY MIDIBASE will not operate properly.

Cleaning

You will find that the PEAVEY MIDIBASE has excellent tracking. This is due to the "SENSING FRET" technology, used in its design.

The PEAVEY MIDIBASE is a fret/string CONTACT system. What this means is that the fret and the string have to make CLEAN CONTACT with each other, so that your PEAVEY MIDIBASE will be able to accurately locate your finger position on the fret. Once the PEAVEY MIDIBASE has ascertained where your fingers are, this information is relayed to the synthesizer, instantaneously, and the result is the sounding of the correct note.

There are many materials that can get between the string and the fret and interfere with contact: grease from your fingers, tarnish on the frets, rust on the strings, lint from unsuitable cleaning cloths, oil from oil-based smoke machines, etc. But DON'T PANIC. The solution is so simple. Just clean your strings.

It is essential to keep not only your strings but also your frets clean and free of tarnish, grease, and grime. It cannot be stressed enough how important this is.

Which leads us to the MOST IMPORTANT piece of information regarding the care of the MIDIBASE, and that is :

NEVER USE STEEL WOOL TO CLEAN FRETS OR STRINGS.

Synthesizers

If you use the Peavey Midibase™ Module or the Spectrum™ Bass module, you will have no MIDI compatibility problems, as these modules have been set up for use in conjunction with the PEAVEY MIDIBASE.

1. MIDI COMPATIBILITY
2. OMNI OFF
3. MULTI MODE
4. PITCH WHEEL SETTING TO + OR - 24 SEMITONES
5. MIDI CHANNEL ALLOCATION

If you do not fully understand how to set these parameters on all the sounds in your synthesizer, you will be unable to operate the system successfully.

DO NOT DESPAIR. The Peavey Spectrum Bass and Midibase Modules have taken the hard work out of parameter setting, etc. As well as having all the necessary MIDI facilities and features required for successful operation of the MIDIBASE, they have also been preprogrammed.

However if you are NOT using one of the above mentioned synthesizers, then there are certain parameters that need to be set in the synthesizer, OR THE SYSTEM WILL NOT OPERATE.

If you are NOT using one of the above mentioned synthesizer modules, then you should now go the section on "SYNTHESIZERS."

SYSTEM OVERVIEW

When you unpack your PEAVEY MIDIBASE, check that the following components are present.

- PEAVEY MIDIBASE GUITAR
- SPLITTER RACK
- POWER PACK
- MIDIBASE CABLE
- MANUAL

At this point, it is a good idea to refer to the SAFETY SECTION (page 34).

Cable Setup And Turning On

If you want to hear the regular bass sound as well as the synthesizer sound, you will need an amplifier with two inputs. If you do not have an amplifier with two or more inputs, then you will have to use an AUDIO MIXER.

The following cables need to be connected.

- The MIDIBASE CABLE is connected between the guitar and the SPLITTER RACK.
- MIDI OUT on the MIDIBASE SPLITTER RACK is connected to MIDI IN on the synthesizer, using a standard MIDI cable.
- The AUDIO OUTPUT of the synthesizer is connected to one input of the amplifier using a standard 1/4" jack to jack cable.
- The AUDIO OUT on the back of the splitter rack is connected to the second input of the amplifier using a standard 1/4" jack to jack cable.
- Now connect the power supplies first to the synthesizer, then connect the power pack to the 16 V AC power input on the back of the splitter rack.
- Make sure the volume settings on the amplifier are set to zero. Now turn the power on to the amplifier, followed by the synthesizer, then finally connect power to the power pack that is plugged into the splitter rack.

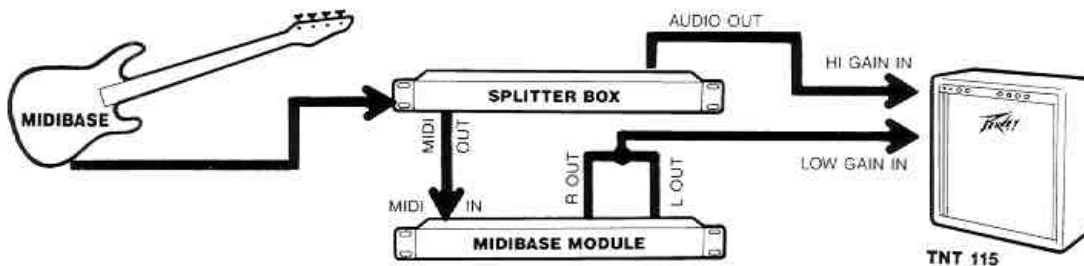

The LED display on the PEAVEY MIDIBASE should now show:



- Turn up volume on both channels of the amplifier.
- Adjust ANALOG VOLUME CONTROL on the PEAVEY MIDIBASE to give you regular bass sound.
- Adjust MIDI VOLUME CONTROL on the PEAVEY MIDIBASE to give you synthesizer sound. (You will also need to check that the volume control on the synthesizer module is turned up.)
- You should now hear SYNTHESIZER and REGULAR BASS sounds.

PERFORMANCE SETUPS

The PEAVEY MIDIBASE is actually an electronically modified bass guitar connected to a computer. The computer electronics are housed inside the back of the bass. This computer generates the MIDI MESSAGE that drives your synthesizer, sequencer, etc.

There are several MIDI functions and parameters in the PEAVEY MIDIBASE which you have to program. This section attempts to explain how all these functions and parameters are laid out, accessed, and fit together.

Rather than supplying a computer keyboard for the input of data to the PEAVEY MIDIBASE, a system has been developed using the FRETS and a single DATA SWITCH.

The DATA SWITCH can be found on the front of the the bass guitar (See the LAYOUT SHEET for exact position.)

The neck of the PEAVEY MIDIBASE is not an ordinary bass guitar neck. Under the black plastic film on the fingerboard, the frets are wired and these wires combine with the MIDI pickups and the electronics in the back of the bass so that you can access the MIDI world.

You will also notice that each fret is divided into four sections. These sections will, from now on, be called FRET SEGMENTS. Each FRET SEGMENT has been assigned a different task. (See "FRET MAP")

To access the task of a given FRET SEGMENT, you must hold down the relevant string so that it makes contact with the relevant fret and at the same time switch the DATA SWITCH. Now look at the LED DISPLAY. This will show an abbreviated four character visualization of the task assigned to that FRET SEGMENT.

The DATA SWITCH is pressed UP to increase the value of the selected parameter and is pressed DOWN to decrease the value. So, the DATA SWITCH is used not only for ACCESS but also for manipulation. One click selects the parameter. Two clicks will change the value of that parameter

Note: EXCEPT in the case of the D and G strings, which are instantaneous when selecting PERFORMANCE SETUP.

When holding down the string on the fret, be careful to only hold down ONE string at a time or you may accidentally trigger the wrong fret.

When CLICKING, always make sure that the string is in contact with the selected fret.

NOTE: Some frets will alter the values of parameters, others will trigger functions, and some frets are non-operational (i.e. they are just frets).

Performance Setups

What is a **PERFORMANCE SETUP**, you ask?

It is exactly that.

You **set up** a sound by manipulating your available parameters until you get a sound that you really like. Then you **store** it in one of the 24 **PERFORMANCE SETUPS**. Later on you can **recall** it quickly and use it during a live performance.

As just mentioned, the PEAVEY MIDIBASE is capable of storing in its memory 24 **PERFORMANCE SETUPS**.

For example:

PERFORMANCE SETUP 1.



PERFORMANCE SETUP 2.



And so on to:

PERFORMANCE SETUP 24.



Each PERFORMANCE SETUP is made up of a number of parameters that can be programmed uniquely to each PERFORMANCE SETUP. This allows you to develop a sound on the PEAVEY MIDIBASE, then store it into one of the 24 PERFORMANCE SETUPS. The PEAVEY MIDIBASE will remember this SETUP even when the power has been turned off. At a click of the DATA SWITCH, the entire sound you have developed can be instantaneously recalled. The main idea of this is for live performance so you can change sounds quickly.

A MIDI foot controller can also be plugged into the MIDI INPUT socket on the MIDIBASE SPLITTER RACK. This will allow you to change sounds with your feet while performing.

These 24 PERFORMANCE SETUPS are accessed from the PEAVEY MIDIBASE by clicking frets 1 - 12 on the G & D strings. For example:

FRET 1	G STRING	PFO1
FRET 2	G STRING	PFO2

and so on to:

THEN	FRET 12	G STRING	PF12
	FRET 1	D STRING	PF13
	FRET 2	D STRING	PF14

and so on to:

FRET 12	D STRING	PF24
---------	----------	------

At this point, set up your PEAVEY MIDIBASE, click on these frets on the D & G strings, and watch the LED DISPLAY change.

If you click on a fret on the G & D string higher than 12,

FRET 13	G string
---------	----------

you will see in the LED display:

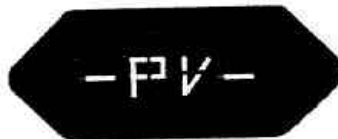

This display indicates that you have clicked on a fret which stores no parameter or alternately has no function. Don't worry, nothing will change in your sound. The -PV- will just appear to indicate that you are on a null fret.

You may now ask, how do I change, or EDIT, a PERFORMANCE SETUP? First, click on a fret on the G or D string and select the PERFORMANCE SETUP you wish to EDIT.

If you wish to EDIT, for example, PERFORMANCE SETUP 18, the LED DISPLAY should now be showing



A copy of the parameters of PF18 are loaded into the "EDIT BUFFER," ready for editing. You do not have to edit these parameters, but you can if you want to.

(The EDIT BUFFER is the part of the computer's memory into which the parameters that make up the PERFORMANCE SETUP are loaded when that particular PERFORMANCE SETUP is being played. When you edit these parameters, it allows you to instantaneously hear what effect they have on your sound. If you like the sound, then you can save it if you want to.)

The parameters are located on the A string as follows:

FRET 1	A STRING	MIDI FORMAT
FRET 2	A STRING	MIDI OUTPUT CHANNEL
FRET 3	A STRING	E STRING PATCH #
FRET 4	A STRING	A STRING PATCH #
FRET 5	A STRING	D STRING PATCH #
FRET 6	A STRING	G STRING PATCH #
FRET 7	A STRING	OCTAVE TRANSPOSE
FRET 8	A STRING	PITCH WHEEL SETTING
FRET 9	A STRING	DYNAMICS ON OR OFF
FRET 10	A STRING	MIDI VELOCITY
FRET 11	A STRING	BEND RANGE
FRET 12	A STRING	STYLE (FINGERS OR PLECTRUM)
FRET 13	A STRING	FOOTSWITCH FUNCTION
FRET 14	A STRING	NOTE OFF FORMAT
FRET 15	A STRING	PERFORMANCE SETUP STORE LOCATION
FRET 16	A STRING	ACTIVATE STORE FUNCTION

(See PERFORMANCE SETUP EDITING section for details on the above.)

FRETS 7, 8, 9, 10		E STRING	BEND CALIBRATION
FRET 7	E STRING	E STRING BEND CALIBRATION	E B (1—32)
FRET 8	E STRING	A STRING BEND CALIBRATION	A B (1—32)
FRET 9	E STRING	D STRING BEND CALIBRATION	D B (1—32)
FRET 10	E STRING	G STRING BEND CALIBRATION	G B (1—32)

FRETS 7, 8, 9, and 10 are concerned with PITCH BEND CALIBRATION

These parameters are used to make the bend of the synthesizer equal to the bend of the natural sound of the string.

NOTE:

This section works in close conjunction with the PITCH WHEEL SETTING. Both of these sections must be set correctly or you will have problems. Also, please refer to the SYNTHESIZER section of this manual to make sure that your synthesizer is set correctly.

Basically, your PITCH WHEEL setting on the MIDIBASE (FRET 8 A STRING) and the PITCH WHEEL SETTING on the synthesizer must be set so that both are displaying the same number.

Thus, if the MIDIBASE LED DISPLAY is showing PW08, then the synthesizer pitch wheel must also be set to 8.

Note:

References to PITCH WHEEL SETTING do not refer to the external pitch wheel found on many synthesizer keyboards, but to the internal PITCH WHEEL PARAMETER which controls the PITCH WHEEL RANGE.

Confusingly, in synthesizers this parameter may be known as a number of different things: e.g. pitch wheel range, pitch bend range, pitch bend (as in the PEAVEY Midibase Module synthesizer), bend, etc. This will depend on which synthesizer you have.

Calibration

After you have checked the above, then set BD=1 (A STRING FRET 12).

Check that the regular bass sound and the synthesizer are in tune. If they are, then bend the string and listen if the synthesizer and string sound are in tune. If not, vary the BEND CALIBRATE parameter for that string until they both come into tune.

FRET 11	E STRING	MIDI SYSTEM EXCLUSIVE DUMP	DUMP / BUSY
---------	----------	----------------------------	-------------

As a new user of the MIDIBASE, do not worry too much about this parameter. This parameter is for advanced users.

This is not actually a GLOBAL setting, but has been put here for convenience.

Switching on this fret instigates a system exclusive MIDI DUMP of the performance setups 1 - 24. The MIDI data is directed to the MIDI OUTPUT socket on the back of the splitter rack. This function allows you to store your performance setups in the PEAVEY MIDI STREAMER™ unit.

Later, you can reload your performance setups if they are accidentally altered, etc. This is achieved by connecting a MIDI cable from the MIDI OUT socket of the PEAVEY MIDI STREAMER to the MIDI IN socket of the PEAVEY MIDIBASE splitter rack. Then send the MIDIBASE SYSTEM EXCLUSIVE file from the PEAVEY MIDI STREAMER to the PEAVEY MIDIBASE.

The LED display on the MIDIBASE will show:



This operation will take approximately one minute. You will need to consult the MIDI STREAMER manual for more details.

FRET 12—21 E STRING

NULL FRETS

— P V —

These frets are non-operational; in other words, they have no function other than their usual role in an ordinary bass guitar.

PERFORMANCE SETUP EDITING

All the parameters that make up a performance setup are located on the A string. The following section deals with the operation and effect of these parameters.

A STRING FRET 1 MODE

There are 5 different modes of MIDI transmission that can be selected:

MON 1

In this mode, only one note can be played at a time. **YOU CANNOT PLAY CHORDS.**

For example, if you play the open E string and then a note on the G string, the E string note will turn off then the G string note will sound.

This mode is great for playing monophonic bass lines. In fact, most bass players use the MONO modes when they play live.

All MIDI data is transmitted on ONE MIDI channel.

If the pitch wheel setting is set to PW08, slides of 8 semitones maximum will be possible. (See "PLAYING TECHNIQUES" section for more details.)

MON 2

This mode should only be used when the pitch wheel setting is on PW08.

As in MON 1, **YOU CANNOT PLAY CHORDS**, as only one note can be played at one time.

The advantage of this setting is that you can play 16 note slides, even though the pitch wheel is set to 8. The limitation is that you cannot play above the 16th fret.

This mode uses pitch wheel MIDI information to establish the pitch rather than note on MIDI information.

PLY 1

This is similar to MON 1 except that you **CAN** play chords.

The PEAVEY MIDIBASE transmits on 4 separate MIDI channels. If the MIDI channel parameter was set to 1, the PEAVEY MIDIBASE would transmit MIDI. (See next section, "FRET 2 MIDI CHANNEL.")

G STRING	MIDI CHANNEL 1
D STRING	MIDI CHANNEL 2
A STRING	MIDI CHANNEL 3
E STRING	MIDI CHANNEL 4

Once again, if the pitch wheel parameter is set to PW08, only 8 note slides maximum are possible.

This facility is supplied so that you only have to change one parameter to change the sounds on all strings.

FRET 5 D STRING PATCH NUMBER

The display will show D = 00—299. This will select which PATCH NUMBER will be selected for the D string.

This parameter only has an effect when modes PLY 1 or PLY 2 are selected. This allows you, if desired, to have a different sound on the A string.

If D=** is displayed, it uses the PATCH NUMBER programmed in FRET 3 E STRING PATCH NUMBER.

FRET 6 G STRING PATCH NUMBER

The display will show G = 00—299 This will select which PATCH NUMBER will be selected for the G string.

This parameter only has an effect when modes PLY 1 or PLY 2 are selected. This allows you, if desired, to have a different sound on the G string.

If G=** is displayed, it uses the PATCH NUMBER programmed in FRET 3 E STRING PATCH NUMBER.

FRET 7 TRANSPOSE

The display will show: T = -2, -1, 0, +1, +2.

This shifts the pitch of the sound up and down 2 octaves.

FRET 8 PITCH WHEEL

This formats the pitch wheel MIDI data that the PEAVEY MIDIBASE transmits:

PW08 The synthesizer pitch wheel MUST be set to + or - 8 semitones.

OR

PW24 The synthesizer pitch wheel MUST be set to + or - 24 semitones.

FRET 9 DYNAMICS

The display will show DY=0 or DY=1

If the display shows DY=1, the synthesizer sound will respond to how hard you pluck the string.

If the display shows DY=0, the synthesizer will NOT respond to how hard you pluck the string, i.e. the PEAVEY MIDIBASE will transmit a constant MIDI velocity if you play loud or soft.

(See the next heading for further details on VELOCITY.)

NOTE: Some early synthesizers do not respond to the VELOCITY MIDI MESSAGE. Also, some sounds in the synthesizers may be programmed specifically to NOT respond to the VELOCITY MIDI MESSAGE.

FRET 10

VELOCITY

The display will show V=00 to 127.

This parameter affects loudness and is closely linked with DYNAMICS. It controls the VELOCITY MIDI MESSAGE the PEAVEY MIDIBASE transmits.

If you have ever played a regular synth keyboard you will have noticed that the harder you hit the keys, the louder and brighter the sound will become. What you are in effect doing is sending varying values of the VELOCITY MIDI MESSAGE.

For example: VELOCITY MIDI VALUE = 6 SOFT
 VELOCITY MIDI VALUE = 127 LOUD

This message varies from 0 to 127.

The VELOCITY parameter in the PEAVEY MIDIBASE gives you some control over how the instrument responds to firm and light playing. The VELOCITY parameter works in conjunction with the DYNAMICS parameter as follows.

When DY=0, the PEAVEY MIDIBASE will not respond to DYNAMICS. Therefore, if you pluck a string firmly or lightly, the synthesizer will only sound at one consistent level. This level is determined by the VELOCITY parameter.

For example: If V=49, the MIDI VELOCITY VALUE of 49 is transmitted whenever a note is plucked, REGARDLESS if it is plucked firmly or lightly.

When DY=1 shows, the PEAVEY MIDIBASE WILL respond to DYNAMICS.

The harder you pluck the string, the higher the VELOCITY MIDI VALUE, so the louder the synth. The VELOCITY parameter in this case provides a ceiling level or maximum value of MIDI VELOCITY transmitted.

For example: V=68

You begin to play lightly at first, then gradually play harder and harder. The MIDI VELOCITY will increase, for example 20, 30, 35, 40, 48, 52, 60, 68, 68, 68...

Even though you are playing hard enough to warrant a higher VELOCITY MIDI VALUE, the computer will limit you to your set value of 68.

This parameter sets the maximum loudness, or VELOCITY, at 127.

NOTE: If V=00, the synth will not sound at all. This can be very useful in a live situation if you are using a MIDI footswitch controller.

As well as programming in all your favorite live synth sounds, program one performance setup with V=00. Then if you do not want synth bass, hit that performance setup. This can be used as a synth "MUTE."

FRET 11

BEND RANGE

The display will show:

	BD=0, 1, 2.
BD=0	The pitch bend is disabled.
BD=1	The pitch bend is normal.
BD=2	The pitch bend is exaggerated by a factor of 2.

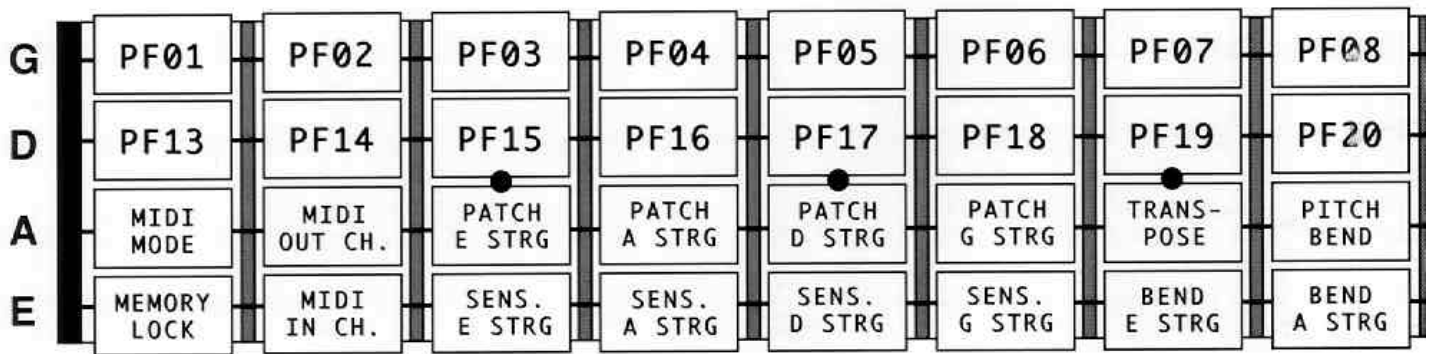

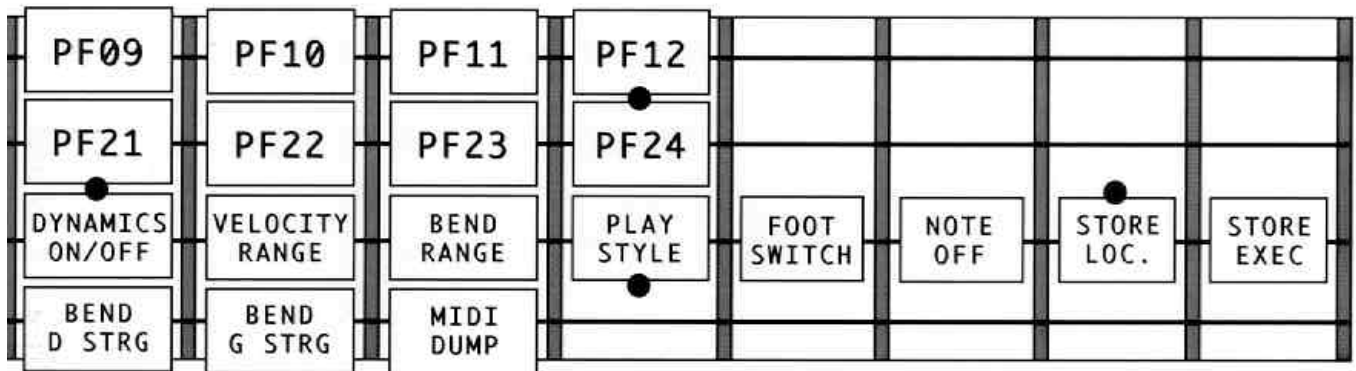

FRET 12**STYLE**

The display will show:

ST=F The STYLE will be set for fingers.

OR

ST=P The STYLE will be set for plectrum.

FRET 13**FOOTSWITCH CONTROL**

This parameter defines what the footswitch will do when pressed. It can be programmed as a hold or modulation switch.

EXAMPLES:

****	NO STRINGS WILL HOLD
H***	E STRING WILL HOLD
***H	G STRING WILL HOLD
HH	A & D STRINGS WILL HOLD
HHHH	ALL STRINGS WILL HOLD
MODU	FOOTSWITCH IS A MODULATION PEDAL

NOTE: When a string is being held, i.e. when your foot is depressing the pedal, YOU CANNOT SLIDE NOTES.

FRET 14**NOTE OFF**

The display will show:

NO=0

Notes will turn off as soon as the vibrations on the string have decayed.

NO=1

Notes will not be turned off as long as a note is fretted.

This gives you infinite sustain on all fretted notes.

FRET 15**STOW**

The display will show >>01 to >>24.

Into this parameter is placed the location at which you want to stow your edited performance setup.

After you have selected the performance setup location, then move to the 15th fret on the A string and click again.

The display will show SURE.

Another click up and the display will show EXEC for a split second, and then the number of the performance setup in which the sound is stored is displayed.

The patch is now said to be STOWED.

Clicking while NOT fretting any string, i.e. all strings are open, will cancel the STOW procedure.

PLAYING TECHNIQUES

The purpose of this section is to help you, the player, come to terms with some of the idiosyncrasies that will become evident when accessing synthesizer sounds using a bass guitar.

The PEAVEY MIDIBASE system was designed to preserve most of your bass playing techniques. However, there are a few minor adjustments that you must make to your technique so that you can realize the full potential of the PEAVEY MIDIBASE system.

When playing the PEAVEY MIDIBASE, the key hints are ACCURACY and COMMITMENT to the note that you are playing.

As you are now an owner of a PEAVEY MIDIBASE, we assume that you are interested in mixing real bass sounds and synthesizer sounds together. The number, size, and texture of the sounds that you can create are limited only by your imagination.

As a contemporary electric bass player, you will be aware that the playing of musical notes is not the only function of bass these days. As well as providing pitch, the bass has a role as a percussive instrument, more now than at any other time in its history. This is evident in the styles of play that are so popular today.

When you use a percussive technique, e.g. slap, while your bass is hooked up to a synthesizer, the nature of MIDI is that the synthesizer will translate this information into notes. To get around this so that you can hear the percussive texture of the sound as well as the pitch, make sure you mix in a high degree of real bass and pull back the synthesizer sound a little.

Finger Style

To play finger style at the optimum using the PEAVEY MIDIBASE, play over the back pickup of the bass.

The Bump Factor

This is best explained using an exercise.

The purpose of this exercise is to illustrate what happens if you are in the habit of resting your fingers on strings while plucking other strings. If you do this while using PLY 1, PLY 2, or PLY 3 modes, you will encounter:

“THE BUMP FACTOR”

1. Make sure that your PEAVEY MIDIBASE is programmed for FINGER STYLE (12th Fret A String).
2. Program the PEAVEY MIDIBASE to PLY 3 (1st fret A string).
3. You will now be able to play chords on the synthesizer via the bass.
4. On the G string hold down the 5th fret, and on the D string hold down the 5th fret.
5. Now, with your finger pluck the G string firmly. The G string will sound and the D string will sound as well!!! When you plucked the G string your finger followed through and bumped into the D string, resulting in the D string triggering as well.
This is what is known as THE BUMP FACTOR.
6. Now hold down the 5th fret on the G string and leave the D string open.
7. Again, pluck the G string. The G string will sound, but this time the open D string will not sound even though you bumped into the D string!!! This is because the computer in the PEAVEY MIDIBASE will not play any open string notes that are bumped, but will play any fretted notes that are bumped.

So, if you are playing a note on a string, make sure that you are not fretting a note on the string above it, or that note may sound as well.

NOTE: THE BUMP FACTOR ONLY OCCURS WHEN THE PEAVEY MIDIBASE IS IN POLY MODES.

Plectrum Style

To play with a plectrum, the PEAVEY MIDIBASE should be set to ST=P (STYLE on A string Fret 12). You may find it necessary to mute the string with your right hand when playing fast passages.

Playing Sounds With Long Decays

Some synthesizer sounds have long decay times, which means after you release the note the synthesizer will still sound.

A problem can arise when playing these long decay sounds. That is, when you take your finger off the fret, you momentarily slide to the fret below. This results in the pitch going flat...which is not a good thing.

To remedy this, make sure when you release your finger from the fret, that you come off cleanly and try to play right over the fret rather than between frets.

Another solution is to use the HOLD footswitch as hammering and slides are disabled when the HOLD switch is depressed.

For these types of sounds, PLY 3 mode is the best mode.

Slap Style

Set STYLE to fingers; i.e. ST=F.

During our period of research and development, we found that one of the most impressive features of the PEAVEY MIDIBASE was that slap players, once they had adjusted to the system, were absolutely blown away by the sounds and effects produced while playing in this style. Slap style playing does take a little bit of work, but it is certainly worth it in the long run.

Hold Footswitch

When the FOOTSWITCH is plugged into the PEAVEY MIDIBASE SPLITTER RACK and is depressed, if a string is assigned to HOLD, then it is not possible to slide notes.

Pull Offs

PULL OFFS cannot be played on the PEAVEY MIDIBASE. If you try to, you will find that the bass will not play the open note.

To achieve the same effect as a PULL OFF, you need to PLUCK the string simultaneously as you release the string.

21st Fret

Note that the 21st fret will not sound MIDI notes. We refer to this fret as a "STOP FRET." It is necessary for wired fret technology.

Tap Style

It is possible to TAP on the PEAVEY MIDIBASE. But, it is absolutely essential to have the pitch wheel and MIDI modes set as follows:

If you have the pitch wheel parameter in the PEAVEY MIDIBASE set to PW24, you must have the MIDI mode set to PLY 1 OR PLY 2.

If you have the pitch wheel parameter set to PW08, then you must have the MIDI mode set to PLY 2.

NEVER USE PLY 3 FOR TAPPING AS IT WILL NOT TRACK.

CARE & MAINTENANCE

MIDI Pickup Adjustments

IMPORTANT:

THE DISTANCE BETWEEN ANY STRING AND THE TOP OF ITS CORRESPONDING PICKUP MUST ALWAYS BE 1/16" (1.5 mm).

If you change the action on your bass, change the gauge of strings that you are using, or alter the distance between the strings and the MIDI pickups, for any reason, you will have to make a MIDI pickup adjustment.

It is ESSENTIAL that these 4 pickups are adjusted correctly.

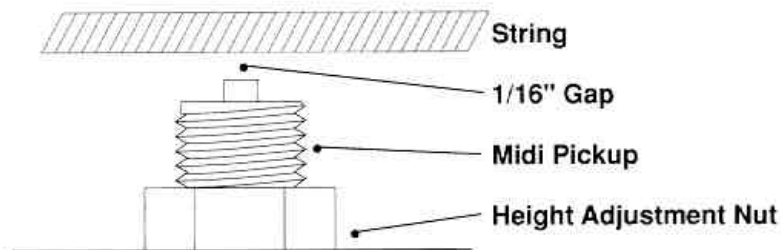

To **RAISE** the pickup, turn the height adjustment nut clockwise.

To **LOWER** the pickup, turn the height adjustment nut counterclockwise.

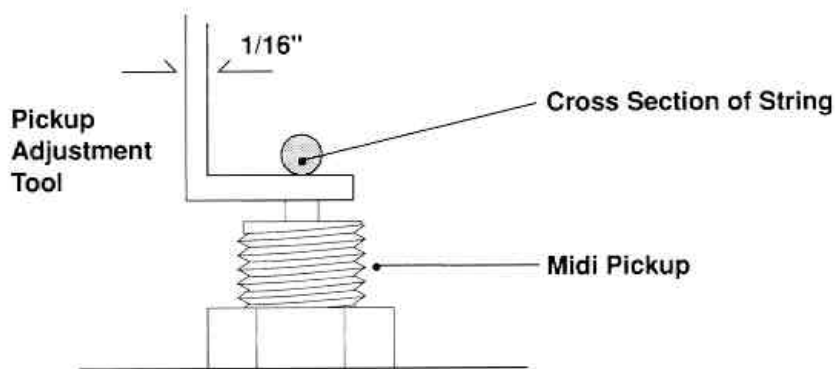

Once the pickups are positioned correctly, select a sound in the synthesizer that responds well to how hard or soft you pluck the string.

In the PEAVEY MIDIBASE, program DY=1 (Dynamics "ON", A STRING FRET 9), and V=127 (Velocity, A STRING—FRET 10). Now play all the strings at a consistent force. Note if any of the strings are too loud.

If a string is too loud, drop its MIDI pickup down a little at a time. Turn the height adjustment nut counterclockwise until the volume level of the string balances with the other strings. Never adjust the pickups so that they are closer than 1/16" from the string.

You may now find that you need to readjust the trigger sensitivities of each string. If so, go to GLOBAL SETTINGS on page 12.

Cleaning Strings

THE PEAVEY MIDIBASE IS A FRET CONTACT SYSTEM.

This means that there must always be good contact between your strings and the frets. So, you **MUST CLEAN YOUR STRINGS** in the following manner.

Fold a lint free cleaning cloth into a rectangular shape and put the cloth under the string as illustrated.

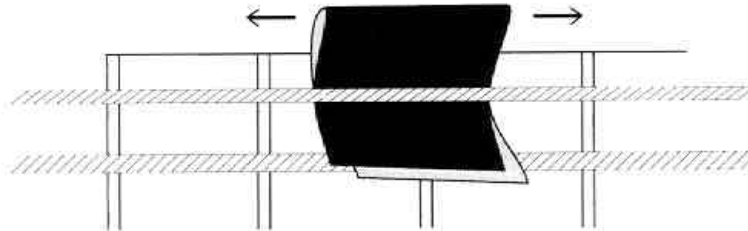

Apply a small amount of the string cleaner to the string which is now lounging comfortably on the folded cloth.

DO NOT SQUEEZE THE BOTTLE

Dab a little of the cleaning fluid on the string.

Fold the cloth over the string and drag back and forth about 5—10 times along the full length of the string.

Do this to each string.

You should clean your strings about once a week or before every live performance.

NOTE: For optimum tracking, use only nickel wound bass strings.

Fret Cleaning

With time, frets will tarnish if not cleaned.

This tarnish, if present, will impede good string/fret contact. A good rule is that every time you change your strings, clean your frets as well.

YOU MUST ONLY USE PLASTIC SCOTCHBRITE SCOURING PADS

*** * NEVER USE STEEL WOOL * ***

Carefully polish the fret. Do not use any cleaning fluids or pastes. Also, be careful not to polish the surface of the fingerboard. You cannot harm it, but with polishing it can end up with an uneven look.

Multi Core Cable

The cable which connects the guitar to the splitter rack is a multi core cable, i.e. it has eight conductors within the cable as compared to a standard 1/4" jack to jack cable which has only two. This cable is built to a high standard with quality Neutrik™ connectors at each end. However, care must be taken, as cables of this sort will break if exposed to harsh treatment.

Smoke Machines

If you use smoke machines during live gigs, be careful that extra care is taken in the cleaning of your PEAVEY MIDIBASE, as an oil residue could possibly build up on the fingerboard, resulting in inferior tracking.

Humid Conditions

If you take your PEAVEY MIDIBASE into a high humidity environment, like the tropics, be sure to pack SILICA GEL CRYSTALS or the like (i.e. moisture absorbing bags) in the case with your PEAVEY MIDIBASE to avoid excessive moisture build up on the fingerboard.

Safety

Read the electronic equipment safety rules at the end of this manual.

Midibase Live!

This section presents a run down of what is involved in using the PEAVEY MIDIBASE in a live situation. What follows is the result of years of experience working with a number of internationally acclaimed bass players who have used MIDIBASE technology in a live situation.

Amplification

If you are using a single channel amplifier, you will require a mixer to blend the real bass with the synthesizer. A rack mount mixer is best, as you will want your live rig to be a rack mounted system.

If you can afford it, an even better system is a stereo rig where you have an amp/speaker for the bass sound and an amp/speaker for the synthesizer.

Also, when selecting a speaker cabinet, look for one that has a better high frequency capability, as the synthesizer is capable of producing much higher harmonics than a regular bass.

MIDI Footswitch

Although not essential, you will probably find a MIDI footswitch controller desirable. This will enable you to change performance setups with your feet. If desired, you can use several sounds in one song. Also, when selecting a MIDI footswitch, select one that has programming features like the PEAVEY RMC™ 2010. This will enable you to not only control the performance setups on the PEAVEY MIDIBASE, but any other effect processors that you have in your rig that are MIDI compatible.

For example, you could assign the PEAVEY MIDIBASE to receive on INPUT CHANNEL 1 by programming the MIDI input parameter (E STRING—FRET 2) to MI=1. Then assign your effects processor to receive on MIDI input channel 2.

So, the MIDI footswitch, when pressing pedal 1, could select PF16 on the PEAVEY MIDIBASE and the digital reverb effect #89 on the effects processor. The MIDI foot switch would transmit :

MIDI CHANNEL 1 - PATCH 16

THEN:

MIDI CHANNEL 2 - PATCH 89

NOTE: When connecting the MIDI footswitch, the MIDI OUT on the footswitch is connected to the MIDI IN on the effects processor. Then, MIDI thru on the effects processor is connected to MIDI IN on the PEAVEY MIDIBASE splitter rack.

The MIDI out on the PEAVEY MIDIBASE splitter rack should ALWAYS be connected to the MIDI in on the synthesizer.

So, in effect, the footswitch selects which performance setup (PF01 TO PF24) the PEAVEY MIDIBASE plays. Then, that performance setup, depending on what sounds are programmed (A STRING—FRETS 3, 4, 5 and 6), selects the sound in the synthesizer to be played.

If you press PEDAL 6 on the footswitch, you could end up playing sound #269 in the synthesizer.

Volume Pedal

To control the level of the synthesizer, a foot volume pedal is very handy. You run the AUDIO OUT of the synthesizer through the foot volume pedal. Once again, this gives you control of the balance of your bass/synthesizer sound while you are actually playing.

Common Problems & Solutions

PROBLEM 1.

THE SYNTHESIZER MAKES NO SOUND WHEN A NOTE IS PLUCKED ON THE BASS.

There are many things that could cause this to happen.

Here is a check list.

- A Check that the power is connected to the PEAVEY MIDIBASE and the synthesizer.
- B Check that the audio out of the synthesizer is connected to the audio input of the amplifier.
- C Check that the volume controls on both the amplifier and the synthesizer module are turned up.
- D Check that the MIDI cable is connected from the MIDI OUT jack on the PEAVEY MIDIBASE splitter rack to the MIDI IN jack on the synthesizer.
- E Check that the MIDI volume control on the PEAVEY MIDIBASE is turned up.
- F Check that the velocity parameter (A STRING—FRET 10) is NOT set to zero.
- G Check that the synthesizer is on the same MIDI channel as the PEAVEY MIDIBASE. (MIDI OUT is located on the A STRING—FRET 2.)
- H The key group range on the synthesizer has not been set to a restrictive value.

PROBLEM 2.

THE SYNTHESIZER IS OUT OF TUNE WITH THE BASS WHEN I HAMMER OR SLIDE A NOTE.

The pitch wheel parameter in the synthesizer must be set to the same value as the pitch wheel parameter in the PEAVEY MIDIBASE (i.e. A STRING—FRET 8).

This parameter can have only one of two values. (i.e. 8 or 24).

The display on the PEAVEY MIDIBASE will show PW08 or PW24.

The synthesizer must be programmed correspondingly to 8 or 24.

PROBLEM 3.

THE SYNTHESIZER IS OUT OF TUNE WITH OTHER GUITARS
IN THE BAND WHEN THEY TUNE TO THEIR TUNERS

Find the master tune parameter on the synthesizer and adjust this value until the synthesizer comes into tune with the guitars.

PROBLEM 4.

WHEN IN MIDI MODES PLY 1 OR PLY 2 (A STRING—FRET 1), THE STRINGS SEEM TO
INTERACT WITH EACH OTHER, ESPECIALLY WHEN SLIDING NOTES.

The synthesizer is probably programmed for **OMNI ON**.

To play in these POLY modes, the synthesizer must be set to **OMNI OFF**.

PROBLEM 5.

ONLY ONE STRING WILL TRIGGER THE SYNTHESIZER.

The synthesizer needs to be put into MULTI mode so it can receive MIDI data on four individual channels.

For example, if the PEAVEY MIDIBASE is set to PLY 1 (A STRING—FRET 1) and its MIDI output channel is set to MO=1 (A STRING—FRET 2), then the synthesizer MUST be set as follows.

MULTI MODE ON, RECEIVING ON MIDI CHANNELS 1, 2, 3, & 4.

PROBLEM 6.

WHEN I ATTEMPT TO SLIDE OR HAMMER A NOTE, THE PITCH DOES NOT CHANGE

It could be one of the following.

- The footswitch is being held down, thus disabling slides.
- The PEAVEY MIDIBASE MIDI mode is set to PLY 3 (A STRING—FRET 1).
- The footswitch is the wrong type. (See PROBLEM 7.)

PROBLEM 7.

NOTES SEEM STUCK ON IN THE SYNTHESIZER.

Check that you have the right footswitch. It should be a Momentary Contact Type.

Unplug the footswitch from the SPLITTER RACK.

If notes are still stuck on, turn the synthesizer main power switch off and back on. Then check your MIDI cables.

NOTE: SEQUENCERS CAN SUFFER FROM THE HABIT OF LEAVING NOTES STUCK ON.

PROBLEM 8.

ONE OR MORE STRINGS SEEM TOO SENSITIVE TO TRIGGER AND PLAY NOTES I DO NOT INTEND.

OR

THE STRINGS ARE TOO INSENSITIVE.

Read the information on setting up the MIDI pickups in the CARE & MAINTENANCE section. (Page 23)

Also, read STRING SENSITIVITIES in the GLOBAL PARAMETERS section. (Page 12)

PROBLEM 9.

WHEN I SLIDE A NOTE UP, THE SYNTHESIZER TRIGGERS NEW NOTES
AND DOES NOT SLIDE UP SMOOTHLY.

If you are playing using your fingers, check that the STYLE parameter (A STRING—FRET 12) is set for FINGERS (i.e. ST=F).

PROBLEM 10.

NOTES SEEM TO WOBBLE IN PITCH.

It is time to clean your PEAVEY MIDIBASE's frets and strings. For more information about this see the CARE & MAINTENANCE SECTION.

PROBLEM 11

ONE STRING SEEMS TO TRIGGER THE SYNTHESIZER MUCH
LOUDER THAN THE OTHER STRINGS.

Set the MIDI mode parameter of the PEAVEY MIDIBASE to MON 1 (A STRING—FRET 1).

If the volume of the string has corrected itself, then the problem is in the synthesizer. You need to read the SYNTHESIZER OPERATING MANUAL and establish how to adjust the volume of individual MIDI channels.

If the string is still too loud, you should read the CARE & MAINTENANCE section on MIDI PICKUP ADJUSTMENT.

Contact Peavey for the name of the nearest authorized service center.

Synthesizers

When selecting a synthesizer module to use with the PEAVEY MIDIBASE, there are several important factors that need to be considered.

The PEAVEY MIDIBASE formats the MIDI data it transmits in a form that emulates, or tracks, what you are playing.

If you want the synthesizer to faithfully reproduce your playing, there are two important functions that your synthesizer must have.

1. It must have the ability to set the pitch wheel range to + or - 24 semitones,

AND

2. It must be able to set to MULTI mode and receive on four different MIDI channels.

The PEAVEY SYNTHESIZER MODULES :

MIDIBASE MODULE
SPECTRUM BASS MODULE
DPM® SP

All support these necessary features.

The MIDIBASE MODULE and SPECTRUM BASS MODULE have been specially designed for use in conjunction with the PEAVEY MIDIBASE.

There are not many synthesizers on the market that can have the pitch wheel set to + or - 24 semitones.

SO BE WARNED!!!

When purchasing a synthesizer, these features **MUST** be available. A good bet is **NOT** to buy a synthesizer until you have actually plugged your PEAVEY MIDIBASE into it and played it to make sure it supports the features you require.

Also, do not underestimate the amount of time, reading, and experimenting that is required to successfully program sounds on a synthesizer module. This is the advantage of purchasing a MIDIBASE or SPECTRUM MODULE, as all this hard work is done for you.

SYNTHESIZERS THAT DO NOT GO TO + OR - 24 SEMITONES ON THE PITCH WHEEL.

If you already have, or intend buying, a synth that is **NOT** capable of having the pitch wheel set to + or - 24, then the only alternative is to set its pitch wheel to + or - 8.

If the pitch wheel does not go to 8, then **DO NOT** buy it or use it with the PEAVEY MIDIBASE, as you will **NEVER** be able to get them in tune.

The limitations of using the pitch wheel set to + or - 8 semitones in conjunction with the 5 MIDI modes (A STRING—FRET 1) are as follows:

MON 1

When you slide a note on the PEAVEY MIDIBASE, it can only be a maximum of 8 semitones. If you slide further than 8, the synthesizer will reach a point where it runs out of range and the synthesizer will fail to track the slide. You will find this mode a little restrictive as you will always have to be careful not to break this rule. In a live situation, this can be a problem as you cannot go back and correct mistakes. However, if you are sequencing into a computer you will find this setup okay.

MON 2

You will be able to achieve 16 semitone slides. The limitation is that you cannot play above the 16th fret. If you do play above the 16th fret, notes will not sound. The PEAVEY MIDIBASE achieves this by using pitch wheel MIDI data to establish all the pitches whether you slide a note or not. If you record into a sequencer while using this mode and then view the notes that have been recorded, you will see only one note value per string and lots of pitch wheel data. In a live situation, this is the better of the two monophonic modes when the pitch wheel is set to + or - 8.

PLY 1

This mode is similar to MON 1 except you will be able to play chords.

PLY 2

This mode is similar to MON 2 except you will be able to play chords.

PLY 3

There are no penalties. This mode works as well as if the pitch wheel was set to + or - 24.

SYNTHESIZERS THAT DO NOT SUPPORT MULTI MODE.

This in effect means that the synthesizer can receive MIDI on ONE channel only.

The only modes that will work will be MON 1, MON 2, AND PLY 3.

THIS LIMITED WARRANTY VALID ONLY WHEN PURCHASED AND REGISTERED IN THE UNITED STATES OR CANADA. ALL EXPORTED PRODUCTS ARE SUBJECT TO WARRANTY AND SERVICES TO BE SPECIFIED AND PROVIDED BY THE AUTHORIZED DISTRIBUTOR FOR EACH COUNTRY.

Ces clauses de garantie ne sont valables qu'aux Etats-Unis et au Canada. Dans tous les autres pays, les clauses de garantie et de maintenance sont fixées par le distributeur national et assurées par lui selon la législation en vigueur.

Diese Garantie ist nur in den USA und Kanada gültig. Alle Export-Produkte sind der Garantie und dem Service des Importeurs des jeweiligen Landes unterworfen. Esta garantía es válida solamente cuando el producto es comprado en E.U. continentales o en Canadá. Todos los productos que sean comprados en el extranjero, están sujetos a las garantías y servicio que cada distribuidor autorizado determine y ofrezca en los diferentes países.

PEAVEY ONE-YEAR LIMITED WARRANTY/REMEDY

PEAVEY ELECTRONICS CORPORATION ("PEAVEY") warrants this product, EXCEPT for covers, footswitches, patchcords, tubes and meters, to be free from defects in material and workmanship for a period of one (1) year from date of purchase, PROVIDED, however, that this limited warranty is extended only to the original retail purchaser and is subject to the conditions, exclusions, and limitations hereinafter set forth:

PEAVEY 90-DAY LIMITED WARRANTY ON TUBES AND METERS

If this product contains tubes or meters, Peavey warrants the tubes or meters contained in the product to be free from defects in material and workmanship for a period of ninety (90) days from date of purchase; PROVIDED, however, that this limited warranty is extended only to the original retail purchaser and is also subject to the conditions, exclusions, and limitations hereinafter set forth.

CONDITIONS, EXCLUSIONS, AND LIMITATIONS OF LIMITED WARRANTIES

These limited warranties shall be void and of no effect, if:

- a. The first purchase of the product is for the purpose of resale; or
- b. The original retail purchase is not made from an AUTHORIZED PEAVEY DEALER; or
- c. The product has been damaged by accident or unreasonable use, neglect, improper service or maintenance, or other causes not arising out of defects in material or workmanship; or
- d. The serial number affixed to the product is altered, defaced, or removed.

In the event of a defect in material and/or workmanship covered by this limited warranty, Peavey will:

- a. In the case of tubes or meters, replace the defective component without charge.
- b. In other covered cases (i.e., cases involving anything other than covers, footswitches, patchcords, tubes or meters), repair the defect in material or workmanship or replace the product, at Peavey's option; and provided, however, that, in any case, all costs of shipping, if necessary, are paid by you, the purchaser.

THE WARRANTY REGISTRATION CARD SHOULD BE ACCURATELY COMPLETED AND MAILED TO AND RECEIVED BY PEAVEY WITHIN FOURTEEN (14) DAYS FROM THE DATE OF YOUR PURCHASE.

In order to obtain service under these warranties, you must:

- a. Bring the defective item to any PEAVEY AUTHORIZED DEALER or AUTHORIZED PEAVEY SERVICE CENTER and present therewith the ORIGINAL PROOF OF PURCHASE supplied to you by the AUTHORIZED PEAVEY DEALER in connection with your purchase from him of this product. If the DEALER or SERVICE CENTER is unable to provide the necessary warranty service you will be directed to the nearest other PEAVEY AUTHORIZED DEALER or AUTHORIZED PEAVEY SERVICE CENTER which can provide such service.

OR

- b. Ship the defective item, prepaid, to:

PEAVEY ELECTRONICS CORPORATION
International Service Center
Highway 80 East
MERIDIAN, MS 39301

including therewith a complete, detailed description of the problem, together with a legible copy of the original PROOF OF PURCHASE and a complete return address. Upon Peavey's receipt of these items:

If the defect is remedial under these limited warranties and the other terms and conditions expressed herein have been complied with, Peavey will provide the necessary warranty service to repair or replace the product and will return it, FREIGHT COLLECT, to you, the purchaser.

Peavey's liability to the purchaser for damages from any cause whatsoever and regardless of the form of action, including negligence, is limited to the actual damages up to the greater of \$500.00 or an amount equal to the purchase price of the product that caused the damage or that is the subject of or is directly related to the cause of action. Such purchase price will be that in effect for the specific product when the cause of action arose. This limitation of liability will not apply to claims for personal injury or damage to real property or tangible personal property allegedly caused by Peavey's negligence. Peavey does not assume liability for personal injury or property damage arising out of or caused by a non-Peavey alteration or attachment, nor does Peavey assume any responsibility for damage to interconnected non-Peavey equipment that may result from the normal functioning and maintenance of the Peavey equipment.

UNDER NO CIRCUMSTANCES WILL PEAVEY BE LIABLE FOR ANY LOST PROFITS, LOST SAVINGS, ANY INCIDENTAL DAMAGES, OR ANY CONSEQUENTIAL DAMAGES ARISING OUT OF THE USE OR INABILITY TO USE THE PRODUCT, EVEN IF PEAVEY HAS BEEN ADVISED OF THE POSSIBILITY OF SUCH DAMAGES.

THESE LIMITED WARRANTIES ARE IN LIEU OF ANY AND ALL WARRANTIES, EXPRESSED OR IMPLIED, INCLUDING, BUT NOT LIMITED TO, THE IMPLIED WARRANTIES OF MERCHANTABILITY AND FITNESS FOR A PARTICULAR USE; PROVIDED, HOWEVER, THAT IF THE OTHER TERMS AND CONDITIONS NECESSARY TO THE EXISTENCE OF THE EXPRESSED, LIMITED WARRANTIES, AS HEREINABOVE STATED, HAVE BEEN COMPLIED WITH, IMPLIED WARRANTIES ARE NOT DISCLAIMED DURING THE APPLICABLE ONE-YEAR OR NINETY-DAY PERIOD FROM DATE OF PURCHASE OF THIS PRODUCT.

SOME STATES DO NOT ALLOW LIMITATION ON HOW LONG AN IMPLIED WARRANTY LASTS, OR THE EXCLUSION OR LIMITATION OF INCIDENTAL OR CONSEQUENTIAL DAMAGES, SO THE ABOVE LIMITATIONS OR EXCLUSIONS MAY NOT APPLY TO YOU. THESE LIMITED WARRANTIES GIVE YOU SPECIFIC LEGAL RIGHTS, AND YOU MAY ALSO HAVE OTHER RIGHTS WHICH MAY VARY FROM STATE TO STATE.

THESE LIMITED WARRANTIES ARE THE ONLY EXPRESSED WARRANTIES ON THIS PRODUCT, AND NO OTHER STATEMENT, REPRESENTATION, WARRANTY, OR AGREEMENT BY ANY PERSON SHALL BE VALID OR BINDING UPON PEAVEY.

In the event of any modification or disclaimer of expressed or implied warranties, or any limitation of remedies, contained herein conflicts with applicable law, then such modification, disclaimer or limitation, as the case may be, shall be deemed to be modified to the extent necessary to comply with such law.

Your remedies for breach of these warranties are limited to those remedies provided herein and Peavey Electronics Corporation gives this limited warranty only with respect to equipment purchased in the United States of America.

INSTRUCTIONS — WARRANTY REGISTRATION CARD

1. Mail the completed WARRANTY REGISTRATION CARD to:

PEAVEY ELECTRONICS CORPORATION
POST OFFICE BOX 2898
MERIDIAN, MISSISSIPPI 39302-2898

- a. Keep the PROOF OF PURCHASE. In the event warranty service is required during the warranty period, you will need this document. **There will be no identification card issued by Peavey Electronics Corporation.**
2. IMPORTANCE OF WARRANTY REGISTRATION CARDS AND NOTIFICATION OF CHANGES OF ADDRESSES:
 - a. Completion and mailing of WARRANTY REGISTRATION CARDS — Should notification become necessary for any condition that may require correction, the REGISTRATION CARD will help ensure that you are contacted and properly notified.
 - b. Notice of address changes — If you move from the address shown on the WARRANTY REGISTRATION CARD, you should notify Peavey of the change of address so as to facilitate your receipt of any bulletins or other forms of notification which may become necessary in connection with any condition that may require dissemination of information or correction.
3. You may contact Peavey directly by telephoning (601) 483-5365.

IMPORTANT SAFETY INSTRUCTIONS

WARNING When using electric products, basic cautions should always be followed, including the following.

1. Read all safety and operating instructions before using this product.
2. All safety and operating instructions should be retained for future reference.
3. Obey all cautions in the operating instructions and on the back of the unit.
4. All operating instructions should be followed.
5. This product should not be used near water, i.e., a bathtub, sink, swimming pool, wet basement, etc.
6. This product should be located so that its position does not interfere with its proper ventilation. It should not be placed flat against a wall or placed in a built-in enclosure that will impede the flow of cooling air.
7. This product should not be placed near a source of heat such as a stove, radiator, or another heat producing amplifier.
8. Connect only to a power supply of the type marked on the unit adjacent to the power supply cord.
9. Never break off the ground pin on the power supply cord. For more information on grounding, write for our free booklet "Shock Hazard and Grounding."
10. Power supply cords should always be handled carefully. Never walk or place equipment on power supply cords. Periodically check cords for cuts or signs of stress, especially at the plug and the point where the cord exits the unit.
11. The power supply cord should be unplugged when the unit is to be unused for long periods of time.
12. If this product is to be mounted in an equipment rack, rear support should be provided.
13. Metal parts can be cleaned with a damp rag. The vinyl covering used on some units can be cleaned with a damp rag, or an ammonia-based household cleaner if necessary. Disconnect unit from power supply before cleaning.
14. Care should be taken so that objects do not fall and liquids are not spilled into the unit through the ventilation holes or any other openings.
15. This unit should be checked by a qualified service technician if
 - a. The power supply cord or plug has been damaged.
 - b. Anything has fallen or been spilled into the unit.
 - c. The unit does not operate correctly.
 - d. The unit has been dropped or the enclosure damaged.
16. The user should not attempt to service this equipment. All service work should be done by a qualified service technician.
17. This product should be used only with a cart or stand that is recommended by Peavey Electronics.
18. Exposure to extremely high noise levels may cause a permanent hearing loss. Individuals vary considerably in susceptibility to noise induced hearing loss, but nearly everyone will lose some hearing if exposed to sufficiently intense noise for a sufficient time.

The U.S. Government's Occupational Safety and Health Administration (OSHA) has specified the following permissible noise level exposures.

Duration Per Day In Hours	Sound Level dBA, Slow Response
8	90
6	92
4	95
3	97
2	100
1½	102
1	105
½	110
¼ or less	115

According to OSHA, any exposure in excess of the above permissible limits could result in some hearing loss.

Ear plugs or protectors in the ear canals or over the ears must be worn when operating this amplification system in order to prevent a permanent hearing loss if exposure is in excess of the limits as set forth above. To ensure against potentially dangerous exposure to high sound pressure levels, it is recommended that all persons exposed to equipment capable of producing high sound pressure levels such as this amplification system be protected by hearing protectors while this unit is in operation.

SAVE THESE INSTRUCTIONS

CALIBRATING THE MIDIBASE

1. To put the bass into calibration mode, click the data switch up and hold it there for approximately 30 seconds.
The display reads as:



2. The display will read as a mix of “!” and “B”.
The “B” indicates the bend for that string is calibrated.
The “!” indicates that the string is out of calibration.
3. Locate the trim pots on the circuit board at the “bridge” end of the control cavity.
4. Adjust each pot until its respective “B” is displayed.
5. At the end of this procedure, the display should read:

 “B B B B”
6. Locate the trim pots on the circuit board at the “neck” end of the control cavity.
7. Hold down the G string at the first fret. The display will read as a mix of “?” and “N”.
8. Adjust the trim pot under the G string until the display reads: “? ? ? N”.
9. Hold down the D string at the first fret.
10. Adjust the trim pot under the D string until the display reads: “? ? N ?”.
11. Repeat this procedure for the A string (? N ? ?) and for the E string (N ? ? ?).



Features and specifications subject to change without notice.

Peavey Electronics Corporation 711 A Street / Meridian, MS 39302-2898 / U.S.A. / (601) 483-5365 / Telex: 504115 / Fax: 484-4278

© 1993

#80301769

Printed in U.S.A. 6/93

Free Manuals Download Website

<http://myh66.com>

<http://usermanuals.us>

<http://www.somanuals.com>

<http://www.4manuals.cc>

<http://www.manual-lib.com>

<http://www.404manual.com>

<http://www.luxmanual.com>

<http://aubethermostatmanual.com>

Golf course search by state

<http://golfingnear.com>

Email search by domain

<http://emailbydomain.com>

Auto manuals search

<http://auto.somanuals.com>

TV manuals search

<http://tv.somanuals.com>