

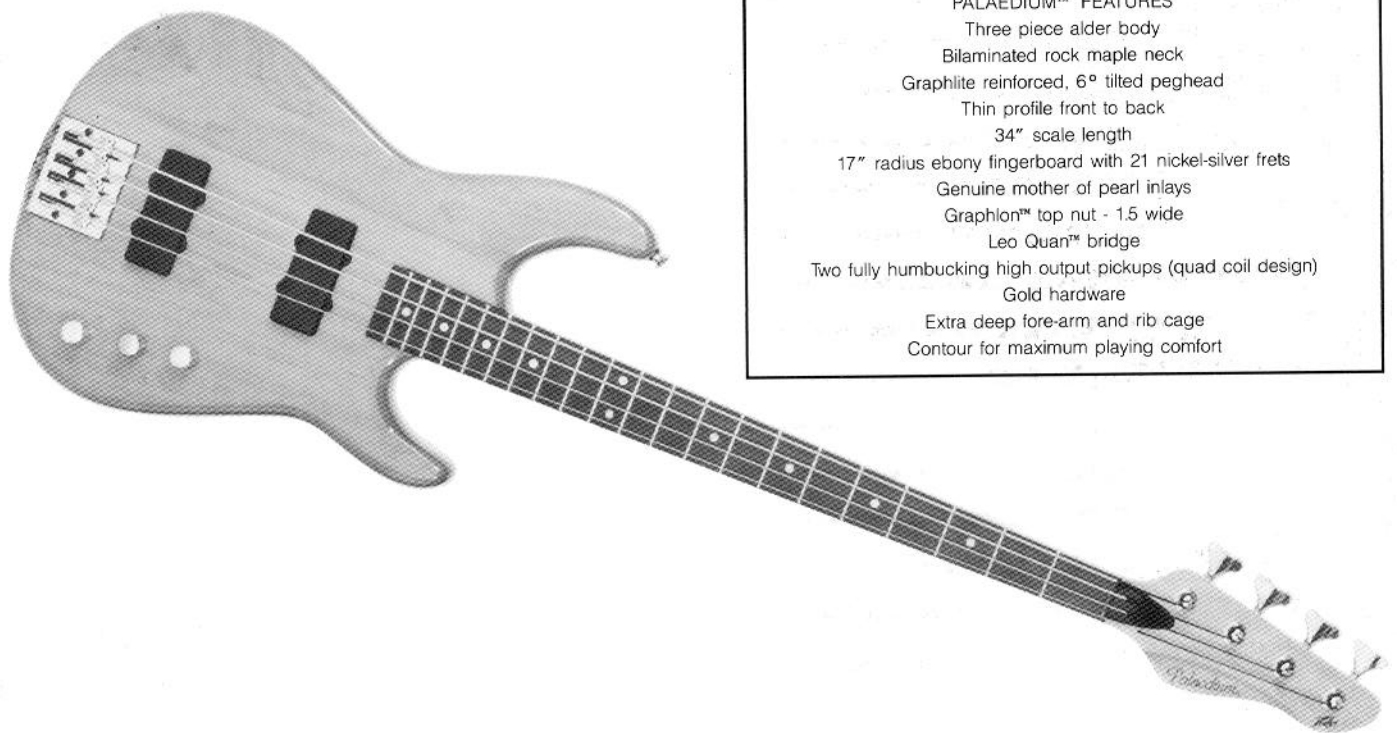

# **PALAEDIUM™**

## **OPERATING GUIDE**

WARNING TO PREVENT ELECTRICAL SHOCK OR FIRE HAZARD, DO NOT EXPOSE THIS APPLIANCE TO RAIN OR MOISTURE. BEFORE USING THE APPLIANCE, READ BACK COVER FOR FUTURE WARNINGS.



#### PALAEDIUM™ FEATURES

- Three piece alder body
- Bilaminated rock maple neck
- Graphlite reinforced, 6° tilted peghead
- Thin profile front to back
- 34" scale length
- 17" radius ebony fingerboard with 21 nickel-silver frets
- Genuine mother of pearl inlays
- Graphlon™ top nut - 1.5 wide
- Leo Quan™ bridge
- Two fully humbucking high output pickups (quad coil design)
- Gold hardware
- Extra deep fore-arm and rib cage
- Contour for maximum playing comfort

**PALAEDIUM™**

### Controls

1. Volume control. The volume control acts as the master volume in that it controls the total signal level delivered from all pickups to the output jack. Rotating the control knob clockwise will increase volume rotating counterclockwise will reduce volume.
2. Blend control. The blend control is offered for a wider variety of sounds than available from conventional pickup selector switches. It may be varied from the neck pickup (full clockwise - CW) to the center detent (both pickups) to the bridge pickup (full counterclockwise - CCW) or any blend in between.
3. Tone control. The tone control operates as a master control. Rotating clockwise will result in more treble (high frequencies) and a brighter tonality. Rotating counterclockwise will result in less treble and a "bassier-type" sound.
4. Output jack. The output jack accepts standard guitar patch cords. (We recommend high quality "shielded" patch cords.)
5. Pickups. The volume level of the pickups can be adjusted by raising or lowering each pickup with its height adjustment screws. Raising the pickup closer to the strings will increase the output and volume. Lowering the pickup away from the strings will decrease output and volume.

### NOTE:

**CARE MUST BE TAKEN TO MAINTAIN ADEQUATE CLEARANCE BETWEEN THE PICKUP AND THE STRINGS. INADEQUATE CLEARANCE CAN RESULT IN POSSIBLE LOSS OF SUSTAIN AND POSSIBLE STRING BUZZING WHEN PLAYING ON THE UPPER FRETS.**



### Neck

The select rock maple neck is of a unique bilaminated construction (U.S. Patent -4,237,944) to provide unmatched rigidity and freedom from warp. Additional reinforcement is provided with graphite bars and an adjustable steel torsion rod. This neck adjusting rod features rolled threads for improved strength and freedom from breakage. (See Adjustment—Torsion Rod for instructions.)

The ultra slim neck (1½" wide at top-nut) features a full 34" scale length, 21 18% nickel-silver frets which are medium height, highly crowned, and polished. The arch of the fingerboard is on an 17" radius to provide exceptional playing ease and string distance/balance characteristics. The neck of the instrument also employs four precision machine heads and a durable Graphlon™ top-nut. The neck is secured to the body with four screws for maximum stability through a solid steel neck plate which features our neck-tilt adjustment. (See Adjustments—Neck Tilt for instructions.) The neck/body joint is also angled for maximum access in the higher fret positions.

#### **Body**

The body of the instrument is constructed from the finest Alder with deep, double cutaways for easy access to the highest fret. A special forearm and rib cage relief contour allows weight reduction, proper balance, and maximum playing ease. The instrument features our polyester/urethane finish which is mar and weather resistant.

#### **Pickups**

The instrument's two quad-coil high output pickups provide high power and full range operation. The pickups have been "harmonically" placed at precise points on the body allowing greater response from the fundamentals and overtones to be obtained from each string. The pickups are shielded for quietness of operation and are fully height adjustable.

#### **Circuitry**

The pickups may be used single or in unison and are controlled by the volume, blend and/or tone control. The volume control is tone compensated to minimize high frequency loss at low volumes.

#### **Bridge**

The bridge is a genuine, heavily gold-plated, Leo Quan BadAss II bass bridge. It features saddle tracks for maximum sustain and string stability and is fully adjustable for string height, tilt, and intonation/compensation. (See Adjustments: Height and Intonation for instructions).

#### **Adjustments**

Your instrument has been carefully adjusted for accurate intonation and playing ease at the Peavey factory. However, your playing style or playing requirements may necessitate additional adjustments at sometime in the future. These adjustments should be made by your Peavey dealer. However, with a little care and by adhering closely to the following instructions, you may attempt these adjustments yourself.

**CAUTION:**  
**PLEASE READ AND UNDERSTAND THE INSTRUCTIONS THOROUGHLY BEFORE ATTEMPTING ANY ADJUSTMENTS!**

#### **Adjusting Torsion Rod**

To set the "straightness" or "relief" of the neck, a Peavey torsion rod wrench No. 75031001 must be used (available from a Peavey Accessory Center).

1. Tune the instrument to standard (A-440) pitch.
2. Check for clearance between the strings (1 through 4) and the first fret. **IMPORTANT:** Use an accurate ruler or similar gauge for this measurement.
3. This clearance should be no less than 1/32" and no more than 1/16" at the first fret.

4. Check for clearance between the strings and the twelfth fret.
5. This clearance should be no less than  $\frac{1}{16}$ " and no more than  $\frac{1}{4}$ " at the twelfth fret.
6. To increase clearance, loosen (counterclockwise) torsion rod nut. To decrease clearance, tighten (clockwise) the torsion rod nut. (The torsion rod nut is located underneath the plastic cover plate on the head stock.)

**CAUTION:**

**IT IS NOT USUALLY NECESSARY TO ROTATE THE TORSION ROD NUT MORE THAN ONE FULL TURN**

**IN EITHER DIRECTION. ONE-QUARTER TO ONE-HALF TURN IS NORMALLY SUFFICIENT TO MAKE MOST ADJUSTMENTS. EXCESSIVE ROTATION MAY CAUSE DAMAGE TO THE NECK AND TORSION ROD. IF EXCESSIVE FORCE IS NECESSARY TO ROTATE THE TORSION ROD NUT, YOU SHOULD CONSULT YOUR PEAVEY DEALER OR THE PEAVEY FACTORY BEFORE ANY FURTHER ADJUSTMENT IS MADE.**

7. Repeat steps 1 through 6 until proper clearance has been reached.

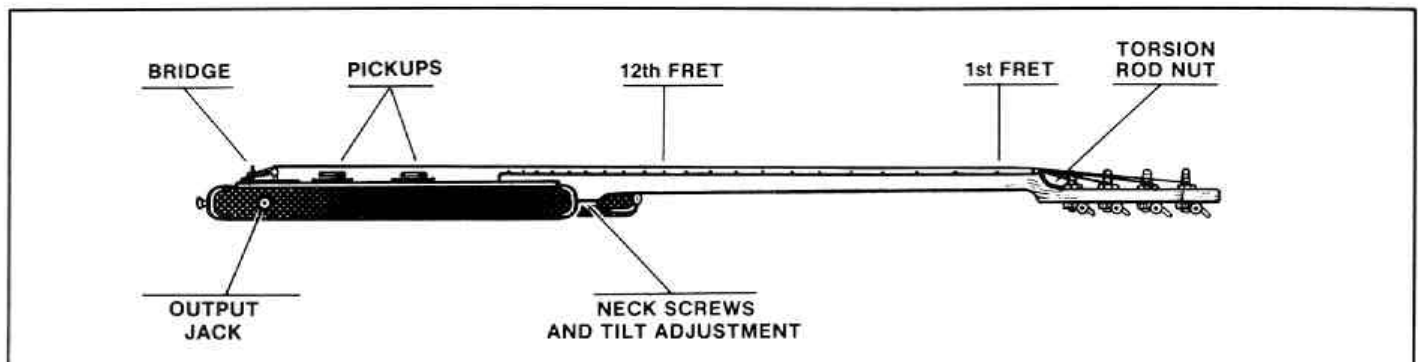

### Neck Tilt

The neck tilt adjustment works in conjunction with the bridge height adjustment to set the overall string playing height. This adjustment should be used whenever possible to set string height rather than the bridge height adjustment.

1. Relieve string tension slightly by de-tuning the instrument. (Approximately 1 to 2 full steps.)
2. Loosen two neck screws closest to headstock, approximately 1 turn.
3. Loosen remaining two neck screws closest to the bridge, approximately 2 turns.
4. String height may now be adjusted with the neck tilt screw, which is located inside the small hole in the neck plate. A  $\frac{1}{8}$ " Allen wrench is used to make this adjustment. Turning the screw clockwise raises the end of the neck, thus bringing the strings closer to the fingerboard.

#### NOTE:

**STRING HEIGHT SHOULD BE ADJUSTED TO FIT YOUR OWN PARTICULAR PLAYING STYLE. IT SHOULD BE NOTED THAT SETTING THE STRING HEIGHT TOO LOW WILL RESULT IN EXCESSIVE STRING BUZZ AND RATTLE—ESPECIALLY WITH A "HEAVY" PLAYING TECHNIQUE. EXCESSIVELY HIGH ACTION WILL RESULT IN INTONATION PROBLEMS AND DECREASED PLAYABILITY.**

5. After adjustment, securely tighten all four neck attaching screws, being careful to balance the torque on all four screws equally.
6. Tune the guitar to standard pitch. Check strings for correct height and playability. If necessary repeat steps 1 through 5 until action is correct.

### Saddle Height Adjustment

The four individual bridge saddles work in conjunction with the neck tilt adjustment to determine the overall string height. Ordinarily, the neck tilt should be used to set the string height. However, individual string saddles can be adjusted to "follow" the curvature (17" radius) of the neck to maximize string/fret distance. Use a  $\frac{3}{64}$ " Allen wrench to make the adjustment for each string.

#### NOTE:

**THIS ADJUSTMENT REQUIRES ACCURATE GAUGES TO MEASURE PROPER STRING/FRET DISTANCES AND THE PROPER RADIUS (CURVATURE) BETWEEN THE NECK AND STRINGS. IF YOU ARE UNFAMILIAR WITH THIS TYPE OF ADJUSTMENT, WE RECOMMEND THAT THIS SETTING BE PERFORMED BY QUALIFIED PERSONNEL AT YOUR AUTHORIZED PEAVEY DEALER.**

### String Intonation

Accurate string intonation settings ensure that your instrument will play in tune at any point on the neck. Although "perfect intonation" is a physical impossibility with a fretted instrument, the correct settings with the bridge and saddle combination of the instrument will maximize the accuracy of individual notes up and down the neck.

Intonation is set by comparing the pitch of an open string to the pitch of the same string when it is played one octave higher at the twelfth fret. The actual "vibrating length" of that string is varied until the notes are both at the right pitch. The "vibrating length" of the string is altered by adjusting the individual bridge saddles either forward or backward, depending on whether the fretted note is sharper or flatter in pitch than the open note. If the fretted note is sharper than the open note, the vibrating length of the string must

be increased—move the bridge saddle to the rear, away from the pickup. If the fretted note is flat, the vibrating length must be shortened—move the bridge forward, toward the pickup to shorten the length.

This instrument features four individual bridge saddles to allow accurate intonation/compensation on each string.

**NOTE:**

**IT IS OFTEN DIFFICULT FOR THE UNTRAINED EAR TO DETERMINE WHEN THE OPEN NOTE AND THE FRETTED NOTE ARE AT PRECISELY THE SAME PITCH. (EXACTLY ONE OCTAVE APART.) SOME PLAYERS FIND THAT COMPARING THE TWELFTH FRET HARMONIC OF THE STRING (RATHER THAN THE OPEN NOTE) TO THE FRETTED NOTE IS MUCH EASIER. A HARMONIC IS PLAYED BY PLUCKING THE STRING WITH THE RIGHT HAND WHILE TOUCHING THE STRING WITH THE LEFT INDEX FINGER (AS LIGHTLY AS POSSIBLE) DIRECTLY ABOVE THE TWELFTH FRET. THE LEFT INDEX FINGER IS DRAWN AWAY AS QUICKLY AS POSSIBLE AFTER THE STRING IS PLUCKED, PRODUCING A "CHIME" EFFECT. THIS CHIMED NOTE IS THEN COMPARED TO THE FRETTED NOTE. FOR EVEN GREATER EASE AND A HIGH DEGREE OF ACCURACY, WE RECOMMEND ONE OF THE MANY TYPES OF ELECTRONIC GUITAR TUNERS THAT ARE AVAILABLE FROM MOST MUSIC STORES. THE TUNERS WHICH USE EITHER A METER OR A MOVING LED DISPLAY ARE USUALLY EASIER TO USE THAN THE TYPE WITH A NUMERICAL FREQUENCY READOUT.**

### Setting Intonation

**NOTE:**

**ALL GUITAR ADJUSTMENTS INTERACT CLOSELY WITH STRING INTONATION. THESE ADJUSTMENTS MUST BE COMPLETED BEFORE ANY ATTEMPT IS MADE TO SET STRING INTONATION AT THE BRIDGE.**

1. Ensure that the torsion rod, bridge height, and neck tilt adjustments have been made and are accurate.
2. Tune the instrument to standard (A-440) pitch.
3. Hold the instrument in a normal playing position. Do not exert any undue pressure on the neck as it will affect intonation settings.
4. Play the first string open (G) and compare it to the pitch of the same string when it is played at the twelfth fret. These notes should be the same.
5. Using a Phillips head screwdriver, adjust the length of the first string saddle so that the open note and the fretted note (or harmonic) are the same.

**NOTE:**

**IT WILL OFTEN BE NECESSARY TO RE-TUNE THE OPEN STRING TO STANDARD PITCH AFTER THE BRIDGE SADDLE POSITION IS ALTERED.**

6. Repeat steps 4 and 5 for the 2nd, 3rd, and 4th strings.
7. Repeat step 1 through 6 as necessary until intonation of all strings are accurately adjusted.

### **Temperature and Humidity**

It is important that your instrument be protected from any extremes or sudden changes in either temperature or humidity. The instrument should be stored in its case whenever it is not in use.

### **Strings**

String life may be greatly extended by frequent cleaning and wiping after use. Dirt and perspiration tend to build up on the underside of the strings so it is often necessary to slide a rag between the strings and the fingerboard. Dirt-laden strings cause tuning and intonation problems as well as rust and corrosion.

For best performance, strings should be changed approximately once a month or every twenty-four hours of playing. Some players may find that they prefer to change strings more often.

#### **NOTE:**

**YOUR INSTRUMENT IS EQUIPPED WITH HIGH QUALITY PEAVEY STRINGS. THE INTONATION AND ACTION OF YOUR INSTRUMENT HAS BEEN CAREFULLY ADJUSTED FOR MAXIMUM PLAYABILITY WITH THESE STRINGS. WHEN STRING REPLACEMENT BECOMES NECESSARY, WE STRONGLY RECOMMEND OUR FIELD PROVEN HIGH QUALITY AND LONG LASTING PEAVEY STRINGS.**

### **Case**

A unique molded and durable plastic case (patent applied for) provides maximum protection and road durability. The case features large storage areas and a padlock tab to facilitate locking for air shipment. The case may be cleaned with a damp cloth with or without soap. Care should be taken to avoid wetting the foam interior.

### **Finish**

Your instrument has a polyester/urethane finish, which is both durable and weather-resistant, but nevertheless needs care. Automotive grade waxes will protect, clean and shine it. Between waxings, the instrument should be wiped with a dry, soft cloth.



### PEAVEY GUITAR ONE-YEAR LIMITED WARRANTY/REMEDY

PEAVEY ELECTRONICS CORPORATION ("Peavey") warrants this Guitar to be free from defects in material and workmanship for a period of one year from date of purchase; PROVIDED, however, that this limited warranty is extended only to the original retail purchaser and is subject to the conditions, exclusions, and limitations hereinafter set forth.

#### CONDITIONS, EXCLUSIONS, AND LIMITATIONS OF LIMITED WARRANTY

This limited warranty shall be VOID and of NO EFFECT if:

1. The first purchase of the product is for the purpose of resale; or
2. The original retail purchase is not made from an AUTHORIZED PEAVEY DEALER; or
3. The product has been damaged by accident or unreasonable use, neglect, improper service or maintenance, or other causes not arising out of defects in material or workmanship.

This Limited Warranty shall not extend to or cover guitar strings. Replacement of guitar strings is deemed to be reasonable and necessary maintenance.

Purchaser's exclusive remedy for breach of this limited warranty is repair of the defect or replacement of the guitar, at the option of Peavey. Service work may be performed by any Peavey Authorized Service Center or, if the service center is unable to provide the necessary warranty service, you will be directed to the nearest other Peavey Authorized Service Center which can provide such service. Or... you may return the guitar, postage prepaid and insured, along with a description of the problem, proof of purchase, and a complete return address to:

PEAVEY ELECTRONICS CORPORATION  
International Service Center  
Hwy. 80 East  
Meridian, MS 39301

If the defect is remedial under this limited warranty, and the other terms and conditions expressed herein have been complied with, Peavey will repair or replace the product and will return it, freight collect, to the purchaser. Other than the postage and insurance requirement, no charge will be made for such repair or replacement.

The liability of Peavey to the purchaser for any cost whatsoever, and regardless of the form of action, whether in contract or in tort, including

negligence, shall be limited to actual damages up to an amount equal to the greater of the purchase price of the product causing the damage or \$500.00.

UNDER NO CIRCUMSTANCES WILL PEAVEY BE LIABLE FOR ANY LOST PROFITS, ANY INCIDENTAL DAMAGES, OR ANY CONSEQUENTIAL DAMAGES ARISING OUT OF THE USE OF OR INABILITY TO USE THE GUITAR, EVEN IF PEAVEY HAS BEEN ADVISED OF THE POSSIBILITY OF SUCH DAMAGES.

The foregoing limitation of remedy will not apply to the payment of cost and damage awards for personal injury or damage to real property or tangible personal property caused by negligence on the part of Peavey.

THIS LIMITED WARRANTY IS IN LIEU OF ANY AND ALL WARRANTIES, EXPRESSED OR IMPLIED, INCLUDING, BUT NOT LIMITED TO, IMPLIED WARRANTIES OF MERCHANTABILITY AND FITNESS FOR A PARTICULAR USE; PROVIDED, HOWEVER, THAT IF THE OTHER TERMS AND CONDITIONS NECESSARY TO THE EXISTENCE OF THE EXPRESSED LIMITED WARRANTY, AS HEREINABOVE STATED, HAVE BEEN COMPLIED WITH, IMPLIED WARRANTIES ARE NOT DISCLAIMED DURING THE ONE-YEAR PERIOD FROM DATE OF PURCHASE OF THIS GUITAR.

SOME STATES DO NOT ALLOW LIMITATION ON HOW LONG AN IMPLIED WARRANTY LASTS, OR THE EXCLUSION OR LIMITATION OF INCIDENTAL OR CONSEQUENTIAL DAMAGES, SO THE ABOVE LIMITATIONS OR EXCLUSIONS MAY NOT APPLY TO YOU. THIS WARRANTY GIVES YOU SPECIFIC LEGAL RIGHTS, AND YOU MAY ALSO HAVE OTHER RIGHTS WHICH MAY VARY FROM STATE TO STATE.

THIS LIMITED WARRANTY IS THE ONLY EXPRESSED WARRANTY ON THIS GUITAR, AND NO OTHER STATEMENT, REPRESENTATION, WARRANTY OR AGREEMENT BY ANY PERSON SHALL BE VALID AS TO OR BINDING UPON PEAVEY.

THE WARRANTY REGISTRATION CARD AND A LEGIBLE COPY OF THE PROOF OF PURCHASES SUPPLIED TO YOU BY THE AUTHORIZED PEAVEY DEALER IN CONNECTION WITH YOUR PURCHASE FROM HIM OF THIS GUITAR SHOULD BE ACCURATELY COMPLETED, MAILED TO, AND RECEIVED BY PEAVEY WITHIN FOURTEEN (14) DAYS FROM THE DATE OF YOUR PURCHASE.

Should notification become necessary for any condition that would require correction, the registration card will help ensure that you are contacted and properly notified.

If you move from the address shown on the WARRANTY REGISTRATION CARD, you should notify Peavey of the change of address so as to facilitate your receipt of any bulletins or other forms of notification which may become necessary in connection with any condition that may require dissemination of information or correction.

The WARRANTY REGISTRATION CARD and subsequent notices of change of address should be mailed to:

PEAVEY ELECTRONICS CORPORATION  
P.O. Box 2898  
Meridian, MS 39302-2898

In the event any modification or disclaimer of expressed or implied warranties or any limitation of remedies contained herein conflicts with applicable law, then such modification, disclaimer or limitation, as the case may be, shall be deemed to be modified to the extent necessary to comply with such law.

The limited warranty is given by Peavey Electronics Corporation with respect to equipment purchased in the United States of America.

#### **DANGER**

**ALL AMPLIFICATION ACCESSORIES, MICROPHONES, MIXERS, ETC., MUST BE PROPERLY GROUNDED AND SHOULD BE UTILIZED WITH A 3-WIRE MAINS SYSTEM IN ORDER TO AVOID ELECTRICAL SHOCK.**

#### **DANGER**

**DO NOT COME INTO CONTACT WITH OTHER ELECTRICAL APPARATUS WHEN PLAYING (OR TOUCHING) YOUR INSTRUMENT. THE METAL PARTS OF THIS INSTRUMENT ARE GROUNDED ACCORDING TO PROPER AND ACCEPTED INDUSTRY PRACTICE, BUT IT IS POSSIBLE TO ENCOUNTER AN ELECTRICAL SHOCK WHEN COMING INTO CONTACT WITH ANOTHER ELECTRICAL APPARATUS IF IT HAS IMPROPER GROUNDING FACILITIES.**

#### **WARNING**

**DO NOT USE IMPROPER OR POORLY DESIGNED GUITAR STRAPS OR OTHER MEANS OF SUPPORT. POSSIBLE INJURY COULD RESULT IF IMPROPER, INFERIOR, ILL FITTING, OR WORN OUT STRAPS ARE USED. THE INSTRUMENT COULD POSSIBLY FALL, CAUSING BODILY INJURY OR DAMAGE TO THE INSTRUMENT OR ASSOCIATED EQUIPMENT IF THE HOLDING DEVICES FAIL FOR ANY REASON.**

#### **DANGER**

**GUITAR STRINGS ARE MADE FROM VERY STRONG STEEL ALLOYS. THEY ARE DESIGNED TO BE USED UNDER TENSION AND, UNDER CERTAIN CONDITIONS, THEY MAY BREAK AND SPRING AWAY FROM THE GUITAR. DO NOT TUNE OR PLAY THIS INSTRUMENT WITH YOUR FACE IN CLOSE PROXIMITY TO THE STRINGS, AS SERIOUS INJURY COULD RESULT IF A STRING SHOULD BREAK.**

#### **WARNING**

**BASS GUITAR STRINGS ARE UNDER CONSIDERABLE TENSION WHEN THEY ARE TUNED TO CONCERT (A-440) PITCH. EXERCISE EXTREME CARE WHEN TUNING (ESPECIALLY ABOVE CONCERT PITCH) OR WHEN EMPLOYING STRING BENDING OR "POPPING" PLAYING TECHNIQUES. THE POSSIBILITY OF STRING BREAKAGE AND PERSONAL INJURY EXISTS UNDER THESE CONDITIONS.**

#### **NOTE**

**THE PATCH CORD BETWEEN THE GUITAR AND THE AMPLIFIER IS AN EXTREMELY IMPORTANT LINK FOR OPTIMUM PERFORMANCE. A HIGH QUALITY, WELL SHIELDED CORD SHOULD BE USED IN THIS APPLICATION.**

BadAss II is a registered trademark of Leo Quan.



Features and specifications subject to change without notice.

**Peavey Electronics Corporation** 711 A Street / Meridian, MS 39302-2898 / U.S.A. / (601) 483-5365 / Telex: 504115 / Fax: 484-4278

©1991

#80301450

Printed in U.S.A. 4/91

## Free Manuals Download Website

<http://myh66.com>

<http://usermanuals.us>

<http://www.somanuals.com>

<http://www.4manuals.cc>

<http://www.manual-lib.com>

<http://www.404manual.com>

<http://www.luxmanual.com>

<http://aubethermostatmanual.com>

Golf course search by state

<http://golfingnear.com>

Email search by domain

<http://emailbydomain.com>

Auto manuals search

<http://auto.somanuals.com>

TV manuals search

<http://tv.somanuals.com>