



PV™1 UHF

Wireless microphone system



CONTENTS	2
INTRODUCTION	3
IMPORTANT SAFEGUARDS	3
RECEIVER	4
INSTRUMENT CONNECTION	6
HANDHELD MIRCROPHONE	6
BODYPACK TRANSMITTER	8
OPENING BATTERY COMPARTMENT	10
SPECIFICATIONS	11

FCC Class B Notice

If your system is FCC Class B, the following applies:

Note – **This equipment has been tested and found to comply with the limits for a Class B digital device, pursuant to Part 15 of the FCC Rules.** These limits are designed to provide reasonable protection against harmful interference in a residential installation. This equipment generates, uses and can radiate radio frequency energy and, if not installed and used in accordance with the instructions, may cause harmful interference to radio communications. However, there is no guarantee that interference will not occur in a particular installation. If this equipment does cause harmful interference to radio or television reception, which can be determined by turning the equipment off and on, the user is encouraged to try to correct the interference by one or more of the following measures:

- Reorient or relocate the receiving antenna.
- Increase the separation between the equipment and receiver.
- Connect the equipment into an outlet on a circuit different from that to which the receiver is connected.
- Consult the dealer or an experienced radio/TV technician for help.

INTRODUCTION

Thank you for purchasing a PEAVEY PV®-1 UHF Diversity Wireless Microphone System. The PV-1 UHF wireless systems have user friendly features and are available in handheld, lavalier, headset and guitar models.

- Clear channel UHF operation in three available frequencies.
- The proprietary compander circuitry yields a dynamic range of up to 120dB
- Squelch control for locking out potential interference. Choice of Transmitters:
 - Bodypack with input level control.
 - Handheld microphone is equipped with a neodymium cartridge that delivers high quality audio reproduction, minimal handling noise and enhanced feedback rejection.
- Diversity receiver allows for maximum reception range and dropout protection, full LED indicators, both ¼" unbalanced and XLR balanced outputs, and special circuitry for noiseless transmitter ON/OFF switching.

IMPORTANT SAFEGAUARDS

CAUTION!

- 1) DO NOT attempt to make internal adjustments to the system. Please refer al servicing to your authorized Peavey Service Center.
- 2) Turn the unit off if it is exposed to excessive moisture while in operation. Allow unit to dry thoroughly, then power back up. If unit fails to power up, then refer unit to your authorized Peavey Service Center.

WARNING! Risk of injury or death if used improperly

DURING INSTALLATION AND SET UP

To reduce the risk of shock DO NOT handle AC/DC adapter with wet hands.

To reduce the risks of fire or shock from damaged power cord always remove cord from outlet by grasping the adapter tightly while unplugging.

To reduce the risk of fire or shock from damaged power cord always turn unit off before

moving it.

To reduce the risk of fire or shock DO NOT expose this equipment to moisture or dust.

To reduce the risk of fire or shock use only with specified voltage.

To reduce the risk of fire or shock DO NOT damage the power cord by placing it near a heat source or stacking heavy items on top of it.

To prevent damage to unit DO NOT place on surface that is unstable or that can tip over.

DURING OPERATION

To reduce the risk of fire or shock DO NOT remove the chassis cover. There are no user-serviceable parts inside. For all repairs refer unit to your authorized Peavey Service Center.

To reduce the risk of fire or shock DO NOT place water or metal items on top of unit.

To reduce the risk of fire or shock DO NOT allow metal, liquids or flammable items fall into unit.

To reduce the risk of fire or shock DO NOT touch AC outlet during thunderstorms.

To prevent injury DO NOT place heavy items on top of unit.

Clear the dust out from the inside regularly. Accumulated dust can create a fire hazard as well as damage to the equipment.

Clear the dust out from plug and AC outlet. Again this accumulated dust can create a fire hazard.

Make sure the AC/DC adapter is plugged in entirely. No exposed metal.

When not in use for long periods of time, turn unit off and remove the AC adapter.

UHF RECEIVER

1. Powering the receiver

Plug the 12V AC/DC ADAPTER provided into the DC INPUT JACK on the back of the receiver. Then plug the power supply into an AC outlet. (Note: Any DC source with 500mA capability can also be used.) Press the POWER SWITCH (1) once to turn on the receiver. The POWER ON LED (1) will now light and the receiver is operational.

2. Antennas

Extend ANTENNAS (5) fully to obtain maximum range. Optimal antenna position is 45 degrees from the receiver (at 90 degrees from each other).

3. Squelch Adjustment

In normal operation, the SQUELCH CONTROL (6) should be set fully clockwise to the factory preset RF level (Max. Sens.). However, in areas of high RF activity, the squelch (or mute, as it is sometimes called) may need to be adjusted to compensate for the adverse conditions in a particular location. If, with the transmitter off, the receiver's A and/or B DIVERSITY LED INDICATORS (3) flicker or stay on, the squelch control should be turned counterclockwise until the A and/or B LEDs extinguish.

When the squelch is properly adjusted, the A and/or B LEDs will only light when the system transmitter is turned on. Turning the squelch control too far counterclockwise will reduce the range, but yield a quieter squelch (mute) function. During operation, especially at ranges greater than 75 feet, one or the other of the A or B LEDs may extinguish briefly. This is normal – the unit's Diversity reception ensures that the received audio will not be interrupted. When both LEDs extinguish, the transmitter is out of range for that given location, and the user should move closer to the receiver to re-establish the radio link.

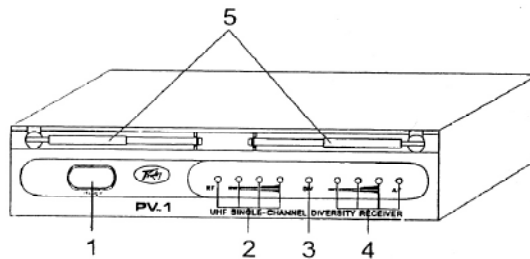

1. Power Switch
2. RF indicator LEDs
3. Diversity LEDs
4. AF indicator LEDs
5. Antennas

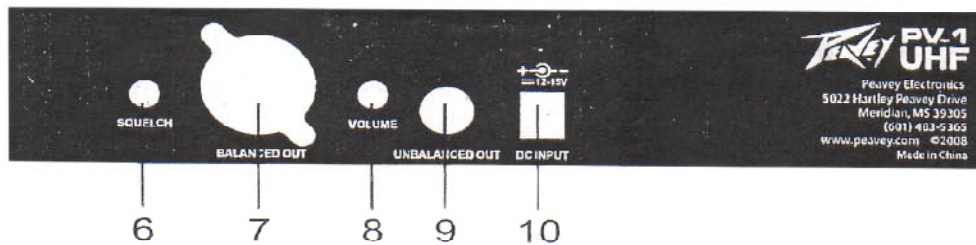

6. Squelch
7. Balanced out
8. Volume
9. Unbalanced out
10. DC Input

4. Connecting the Audio Output

The UHF receiver provides both a fixed mic level BALANCED MIC AUDIO OUTPUT XLR (7) and an adjustable line level AUX AUDIO OUTPUT ¼" JACK (9).

[Note: As when making any connection, make sure the amplifier or mixing board volume is at the minimum level before plugging in the receiver to avoid possible sound system damage.]

INSTRUMENT CONNECTION

Insert an audio cord with a ¼" mono phone plug in the AUX AUDIO OUTPUT JACK (9) on the rear panel of the receiver. Plug the other end of the cord into an amplifier, effects, or mixing board. Adjust the AUX VOLUME CONTROL (8) on the UHF receiver clockwise until the volume level is comfortable for your application. This setting is roughly equivalent to a direct instrument cord connection.

Microphone connection (using the transmitter with either a headset or lavalier microphone or the handheld microphone transmitter)

For Microphone use, either the BALANCED MIC AUDIO OUTPUT XLR (7) or the ¼" line level AUX AUDIO OUTPUT (9) can be used. The XLR output is set at a nonadjustable microphone level, similar to wired mic levels. Plug an XLR connector into the XLR output connector on the rear of the unit and plug the other end into your amplifier or mixing board.

Make sure the volume is turned down when making connections. For your convenience, the XLR output level is preset at the factory and is not adjustable with the receiver volume control.

The receiver is equipped with an AF PEAK LED INDICATOR (3) which lights with a strong audio signal from the transmitter. Occasional flickering on loud inputs to the transmitter is normal. If the LED lights continuously, decrease the volume to the transmitter or overload distortion may result.

HANDHELD MICROPHONE

1. Unscrew the BATTERY COMPARTMENT COVER (13) and remove, exposing the BATTERY HOLDER (14). Insert a fresh 9V ALKALINE BATTERY (15), observing the correct polarity as marked, and screw the cover back on to the microphone. Make sure the cover is screwed on completely. A fresh alkaline battery can last up to 10 hours in use, but in order to ensure optimum performance, it is recommended that you replace the battery after every 7-8 hours of use.
2. Turn on the microphone by sliding the OFF/STANDBY/ON SWITCH (16) to the STANDBY position (transmitter on, audio muted) or the ON position (transmitter and audio both on). The BATTERY INDICATOR LED will give a single quick flash, indicating usable battery strength. In the case of a dead or low battery, the LED will either not illuminate at all or will stay on continuously, indicating that the battery should be replaced.

3. The microphone is now ready to use. The A and/or B DIVERSITY LED INDICATORS (2) on the receiver should now be lit, indicating a received signal from the transmitter. When ready to speak, slide the transmitter switch to the ON position. Adjust the volume of the receiver as per the Audio Output Microphone Connection section of the above receiver instructions.

[Note: Observe care in selecting P.A. volume, transmitter location and speaker placement so that acoustic feedback will be avoided.]

**To preserve battery life, turn the transmitter off when not in use.*

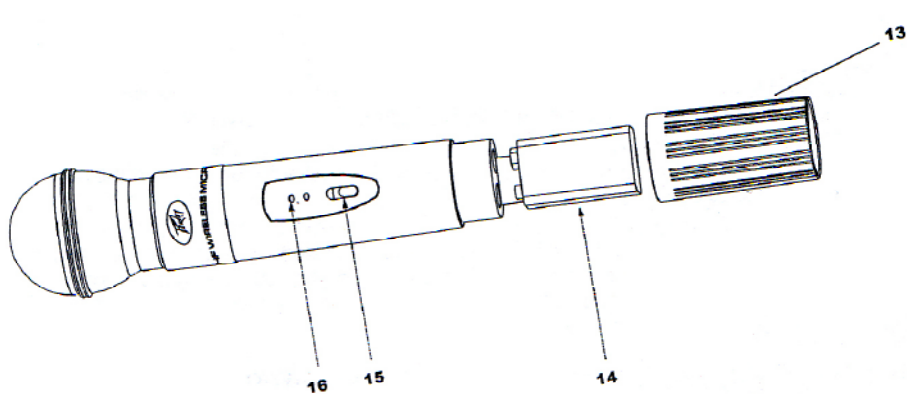

- 13. Battery compartment cover
- 14. 9V Alkaline battery
- 15. On/Standby/Off switch
- 16. Battery indicator LED

BODYPACK TRANSMITTER

1. Slide open the hinged BATTERY COMPARTMENT (18) and insert (2) fresh AA ALKALINE BATTERIES (19), observing the correct polarity. Fresh alkaline batteries can last up to 10 hours in use, but in order to ensure optimum performance, it is recommended that the battery be replaced after 7-8 hours of use.
2. The body pack is equipped with a 3.5mm LOCKING JACK (21) for connecting the audio input selected. Connect either the INSTRUMENT CORD (22) or the HEADSET MIC (23) or LAVALIER

MIC CORD (24) as desired. To secure the connection, insert locking mini-XLR into the jack. To unplug, reverse the process.

Slip the transmitter into a pocket or CLIP (28) it on to your clothes or instrument strap (if using it as an instrument transmitter). The CLIP can be rotated 90 degree if the transmitter is to be attached horizontally (instead of vertically) by loosening the screws holding the clip.

3. Turn on the body pack transmitter by sliding the OFF/STANDBY/ON SWITCH (26) to the STANBY position (transmitter on, audio mute or the ON position (transmitter and audio both on). The BATTERY INDICATOR LED (25) will give a single quick flash, indicating usable battery strength.

In the case of a dead or low battery, the LED either will not illuminate at all or will stay on continuously, indicating that the battery should be replaced. To preserve battery life, turn the transmitter off when not in use. The transmitter is now ready to use. The A and/or B DIVERSITY LED INDICATORS (2) on the receiver should now be lit, indicating a received signal from the transmitter.

4. Instrument Use

Plug the ¼" phone plug from the INSTRUMENT CORD (22) into the instrument. As the cord to the instrument also serves as the antenna, be sure to extend it fully for maximum range. Rolling up or shortening the cord may reduce the effective operating range. When ready to play, slide the audio OFF/STANDBY/ON SWITCH (26) to the ON position. Adjust the volume of the receiver as per the audio Output Instrument Connections section of the above UHF receiver instructions.

(Note: Levels should be adjusted with the volume control of your instrument.)

The AF PEAK LED INDICATOR (3) on the UHF receiver will light for all loud input signals. Occasional flickering on and off during use is normal, however if the LED stays on continuously, turn down the instrument volume or noticeable distortion may result.

(Note: Scratchy noises can sometimes occur when some electric guitars with dirty pots or connections are used with any wireless system. Therefore, the supplied INSTRUMENT CORD (22) has a factory installed capacitor inside the ¼" plug. This capacitor provides first order filtering of the RF signal from the cord into the guitar and eliminates virtually all scratchy noises. Should your equipment still give you scratchy noises, we suggest these steps to eliminate them:

- a) *Make sure all guitar volume and tone pots are clean and all contacts are soldered, this is very important.*
 - b) *A 47pf capacitor soldered across the hot to ground terminals of the guitar's volume and tone pots will provide extra filtering.*
5. Microphone Use (with either a lavalier or headset microphone)

Secure the connection from the LAVALIER (24) or HEADSET MIC CORD (23), to secure the connection, insert locking mini-XLR into the jack. To unplug, reverse the process.

To use the lavalier mic, attach it at chest level or higher. Do not place it too close to the mouth – a distance of about six inches is recommended. To use the headset mic, place it on your head and adjust the boom so that the mic is about one inch to the side of the front of the mouth. As the microphone cord also serves as the antenna, be sure to extend it fully. Rolling up or shortening the cord may reduce the effective operating range – keep it as straight as possible.

When ready to speak, slide the OFF/STANDBY/ON SWITCH (26) to the ON position. Adjust the volume of the receiver as per the Audio Output Microphone Connection section of the above UHF receiver instructions.

[Note: Observe care in selecting P.A. volume, transmitter location and speaker placement so that acoustic feedback will be avoided. Unidirectional mics are more resistant to feedback, but pick up sound equally from all directions, and are prone to feedback if not used carefully. Unidirectional mics are more resistant to feedback, but pick up sound sources best that are directly in front of the mic. Also, mics that are farther from the sound source, such as lavaliers, require more acoustic gain and thus more prone to feedback than close-source mics such as handheld or headset models that are used close to the mouth.]

The AF PEAK LED INDICATOR (3) on the UHF receiver will light for all loud input signals.

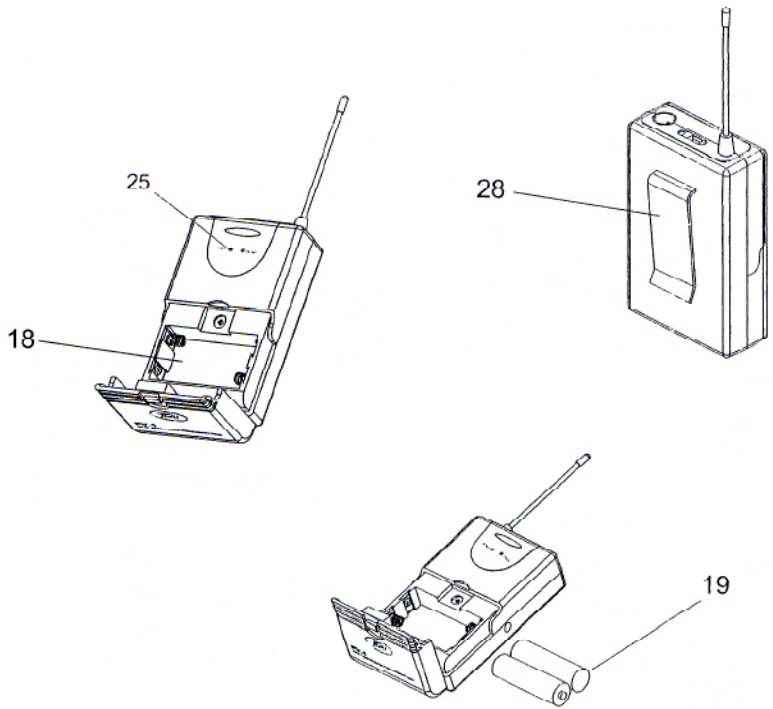
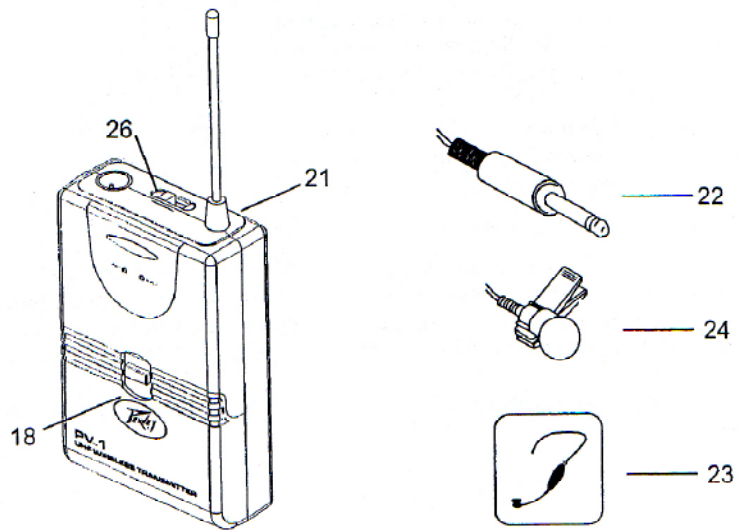

- 18. Battery Compartment
- 19. AA Batteries
- 21. 3.5 mm Locking Jack
- 22. Instrument Cord

- 23. Headset Mic
- 24. Lavalier Mic
- 25. Battery Indicator LED
- 26. On/Off/Standby Switch
- 28. Clip

SPECIFICATIONS

- Frequency Response 50Hz – 15 KHz, +/- 3dB
- Dynamic Range 120dB
- Total Harmonic Distortion <0.6%
- RF Carrier Frequency Range UHF, choice of single frequencies from 906.000 to 923.700MHz
- Frequency Stability +/- 0.005%, Crystal controlled
- Modulation FM (F3E), +/-20KHz
- Operating Range Up to 250 ft. typical (depending on site conditions); up to 500+ feet optimum line of sight

TRANSMITTERS

Audio Inputs

- Body pack 3.5mm locking mini-jack
- Body pack requires 2 AA batteries
- Handheld Integrated Neodymium dynamic cartridge controls
- OFF/STANDBY/ON, switch
- LED Indicator Unit "ON" (single flash)
- Low Battery Alert (Steady)
- RF Power Out 50mW (max. allowed by FCC)
- Harmonic & Spurious Emissions > - 50dB
- Battery 9V Alkaline
- Battery Life up to 8-10 hours
- Dimensions 4.2" x 2.5" .88"
(10.7 x 6.4 x 2.2 cm)
9.5" x 1.37"
(24.1 x 3.48 cm)
- Weight 3 oz (84g) – 7.5 oz (210g)

RECEIVER

- Reception Mode – Diversity(Dual Antenna)
- Controls – Power ON/OFF, volume control, squelch (mute) control
- Connectors – DC in, ¼" unbalanced phone jack, XLR balanced output
- LED Indicators – Power ON, Audio Peak, A/B Diversity
- Power Requirements – DC 12-15V @ 500 mA, AC/DC adapter included
- Squelch – Tone Key (32.768 KHz), external control
- Unwanted Signal Rejection 60dB image and spurious
- Dimensions 16" x 9.4" x 1.73"
- Weight 1.15 lb (0.52 kg)

Features and specifications subject to change without notice.

EX000127

Peavey Electronics Corporation
5022 Hartley Peavey Drive
Meridian, MS 39305
(601) 483-5365 © 2011
www.peavey.com



Free Manuals Download Website

<http://myh66.com>

<http://usermanuals.us>

<http://www.somanuals.com>

<http://www.4manuals.cc>

<http://www.manual-lib.com>

<http://www.404manual.com>

<http://www.luxmanual.com>

<http://aubethermostatmanual.com>

Golf course search by state

<http://golfingnear.com>

Email search by domain

<http://emailbydomain.com>

Auto manuals search

<http://auto.somanuals.com>

TV manuals search

<http://tv.somanuals.com>