



## PVM™ 520TN

Unidirectional  
Cardioid  
Neodynamic Microphone

### SPECIFICATIONS:

**Element Type:**

Dynamic

**Magnet Composition:**

Neodymium Iron Boron

**Polar Pattern:**

Cardioid

**Front-To-Back Rejection:**

20 dB typical

**Impedance:**

400 ohms

**Frequency Response:**

45 Hz to 19 kHz

**Sensitivity:**

-52 dB 0 dB = 1 mW/pascal

**Open Circuit Voltage:**

-68 dB 0 dB = 1 volt/mBar

**Case (Housing):**

Aluminum

**Finish:**

Black hard coat

**Pop Filter:**

Dual integral open cell foam

**Phasing:**

Positive (inward) pressure on diaphragm produces positive voltage at pin #2

**Weight:**

.62 Lbs. (277 g)

### FEATURES

- Neodynamic design
- Cardioid polar response
- Titanium laminate diaphragm
- Neodymium magnetic
- Superior off axis rejection
- Low frequency polar response control (below 100 Hz)
- Smooth, accurate frequency response
- Accurate instrument reproduction
- Ultra-high sensitivity

### DESCRIPTION

The PVM™ 520TN is a high performance instrument microphone that is unique in its ability to maintain superior off axis rejection. Many conventional instrument microphones lose their ability to discriminate against unwanted sounds below 500 Hz. This is to say, they become essentially omnidirectional products below there and are of limited use in many instrument micing applications. The PVM 520TN maintains control of polar response down to and below 100 Hz making it an ideal choice even in critical recording environments. The 520TN performs excellently when very low frequency reproduction is required, such as kick drums, floor toms and other instruments with very low frequency fundamentals. Because the PVM 520TN exhibits such smooth and accurate response, it is also ideal for the brass and woodwind families. The excellent transient response of the PVM 520TN also indicates its usage as

an uncolored and extremely accurate vocal microphone. This coupled with the extremely high output sensitivity enables the PVM 520TN to be used in many applications where in the past only expensive condenser-type instrument microphones were applicable.

**ARCHITECTURAL & ENGINEERING SPECIFICATIONS**

The microphone shall be a moving coil dynamic with a frequency response of 45 Hz to 19 kHz. The microphone shall have a cardioid polar characteristic typically 20 dB down from the front response. The microphone shall have an output power level of -52 dB where 0 dB = 1 milliwatt per pascal and nominal impedance of 400 ohms.

The microphone shall have a black hard coat finish that can withstand the toughest of conditions. The microphone shall have a yoke type mounting bracket that uses a standard mic clip for stand mounting. The connector shall be a 3-pin XLR equivalent audio type. The microphone shall have an overall dimension of 4.80 x 1.950. The microphone shall be a PVM™ 520TN or equivalent.

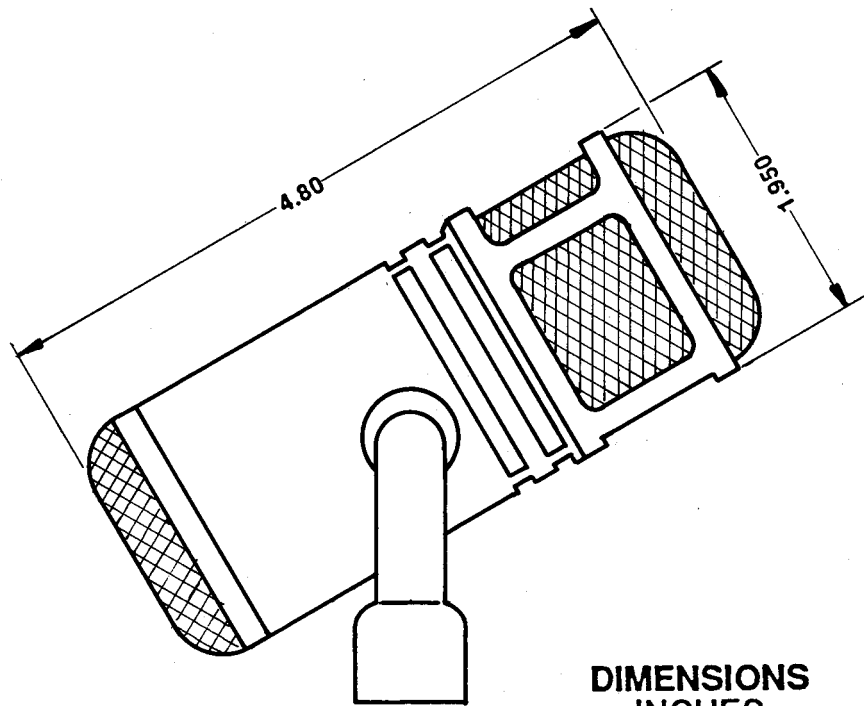

**DIMENSIONS INCHES**

**FREQUENCY RESPONSE**

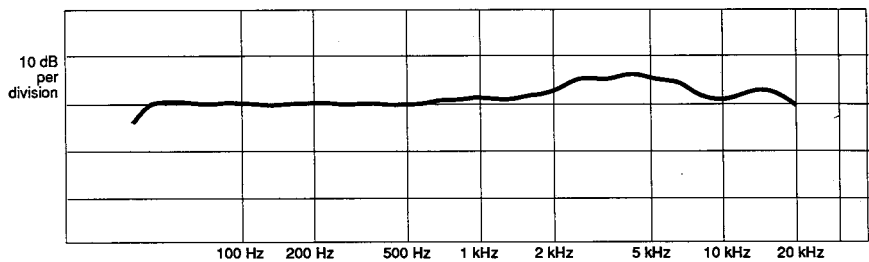

**0° & 180° FREQUENCY RESPONSE**

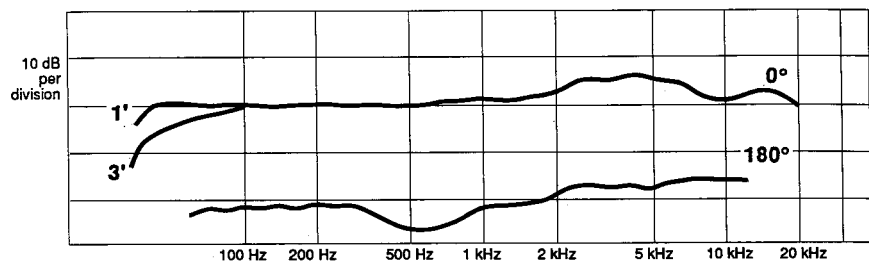

Proximity effect is a naturally occurring phenomenon in unidirectional microphones. The effect is to accentuate or boost the low frequency response. This effects is a function of distance from the diaphragm to the source and increases as the diaphragm is moved closer to the source.

## POLAR PATTERNS

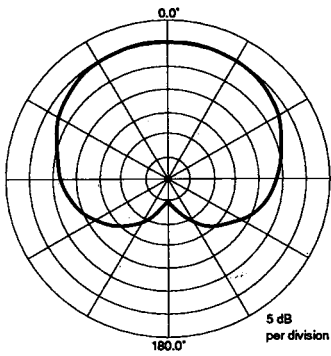

200 Hz

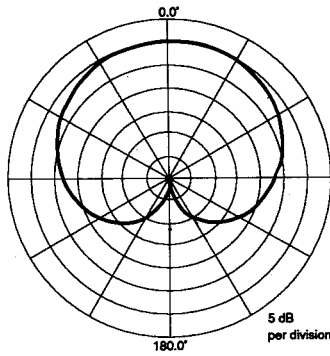

500 Hz

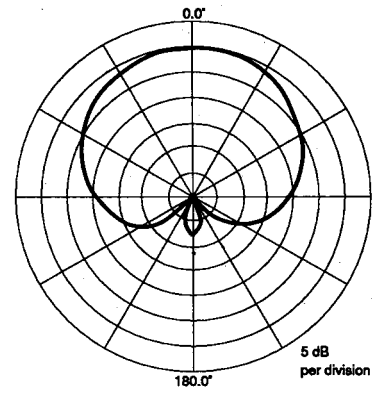

1500 Hz

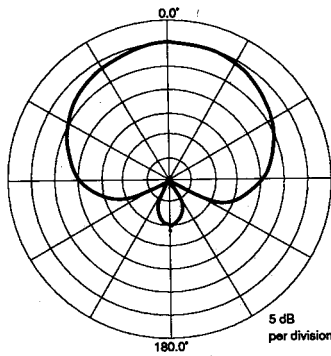

2 K

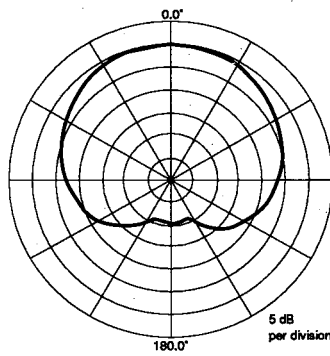

4 K

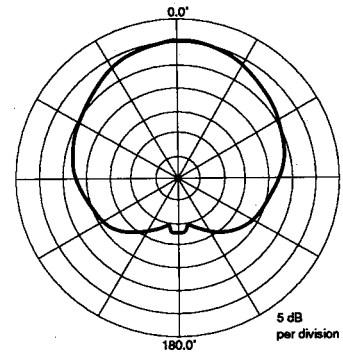

6 K

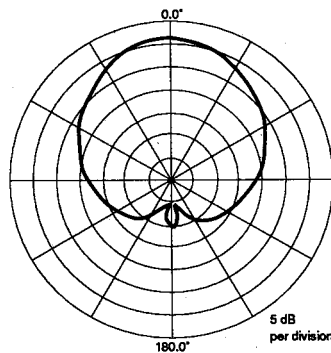

7 K

## WIRING DIAGRAM

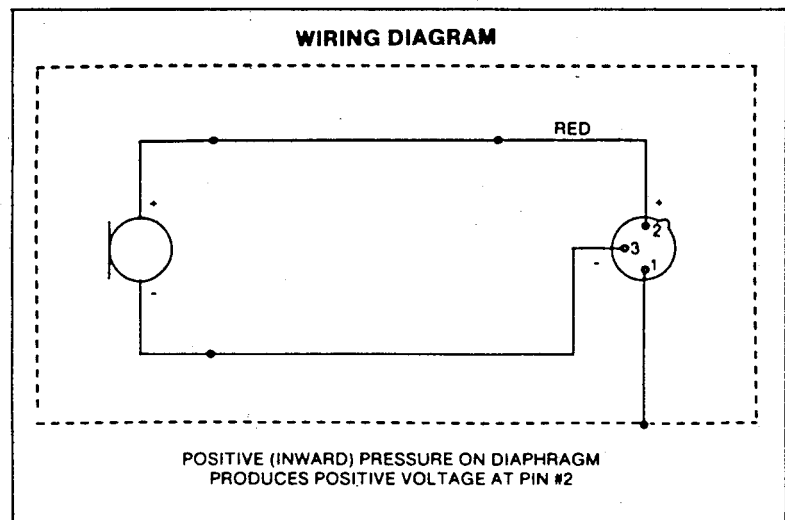

## ONE YEAR LIMITED WARRANTY --

Note: For details, refer to the warranty statement. Copies of this statement may be obtained by contacting Peavey Electronics Corporation, P. O. Box 2898, Meridian, Mississippi 39302-2898.

## ACCESSORIES

Carrying case, swivel adaptor, foam windscreen, 25' (7.62M) balanced low Z cable.

## Free Manuals Download Website

<http://myh66.com>

<http://usermanuals.us>

<http://www.somanuals.com>

<http://www.4manuals.cc>

<http://www.manual-lib.com>

<http://www.404manual.com>

<http://www.luxmanual.com>

<http://aubethermostatmanual.com>

Golf course search by state

<http://golfingnear.com>

Email search by domain

<http://emailbydomain.com>

Auto manuals search

<http://auto.somanuals.com>

TV manuals search

<http://tv.somanuals.com>