

PVM™ T9000

STUDIO MICROPHONE

O P E R A T I N G G U I D E

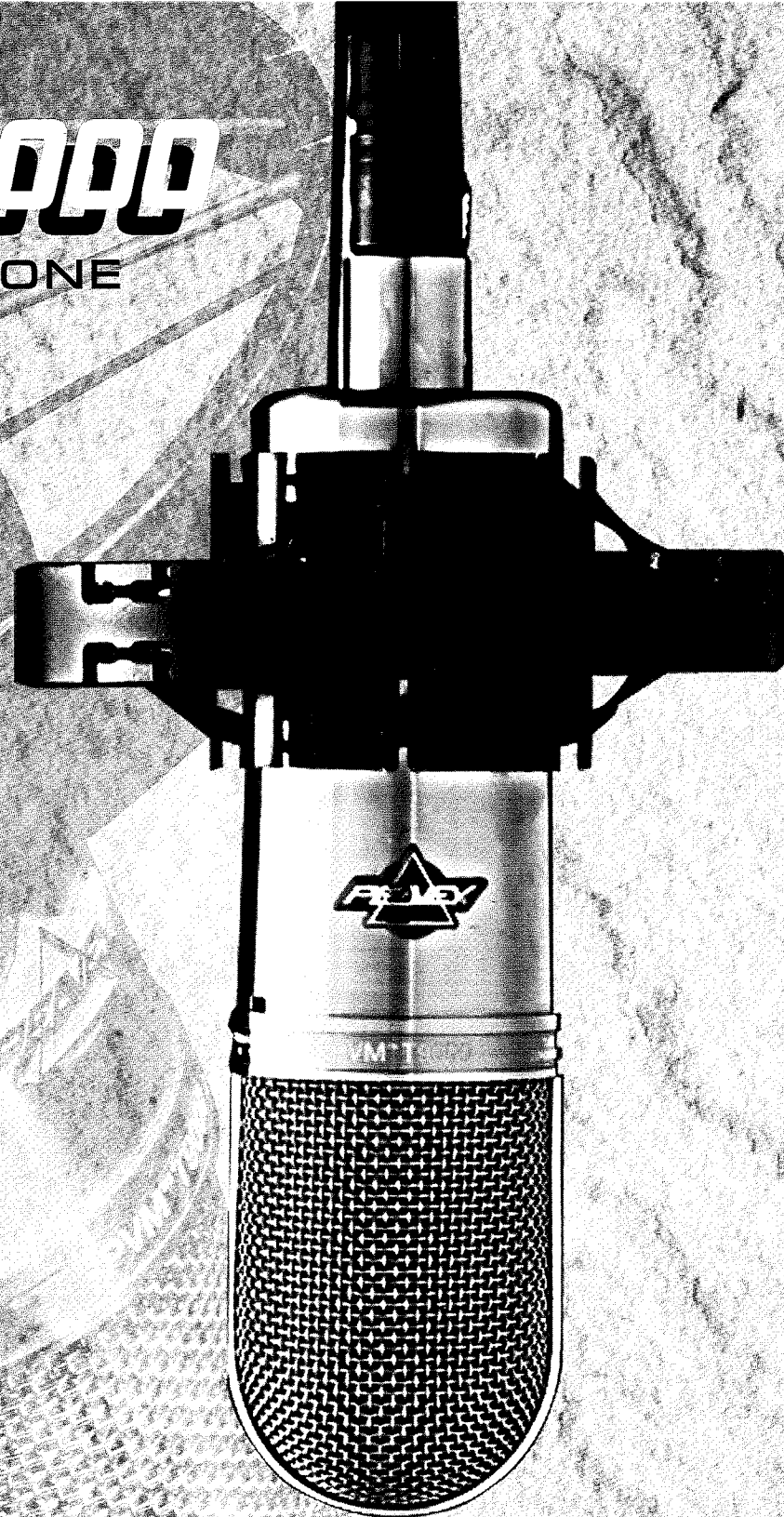

PEAVEY®



Intended to alert the user to the presence of uninsulated "dangerous voltage" within the product's enclosure that may be of sufficient magnitude to constitute a risk of electric shock to persons.



Intended to alert the user of the presence of important operating and maintenance (servicing) instructions in the literature accompanying the product.

CAUTION: Risk of electrical shock – DO NOT OPEN!

CAUTION: To reduce the risk of electric shock, do not remove cover. No user serviceable parts inside. Refer servicing to qualified service personnel.

WARNING: To prevent electrical shock or fire hazard, do not expose this appliance to rain or moisture. Before using this appliance, read the operating guide for further warnings.



WARNING: MICROPHONE INPUT CONNECTION ON THE POWER MODULE CONTAINS DANGEROUS VOLTAGE. DISCONNECT POWER FROM MAINS BEFORE SERVICING.



CAUTION: MICROPHONE POWER CABLE CONTAINS DANGEROUS VOLTAGE. TURN POWER OFF AND DISCONNECT CABLE FROM POWER MODULE BEFORE SERVICING.

WARNING: PVM™ T9000 MICROPHONE HOUSES DANGEROUS VOLTAGE. DO NOT OPEN MICROPHONE CASE UNLESS ALL POWER IS OFF AND MICROPHONE POWER CABLE IS DISCONNECTED.

PVM™ T9000

Features

- **Large format diaphragm**
- **Vacuum tube preamp**
- **Uniform cardioid polar pattern**
- **Studio shock mount suspension with a unique finned heat sink holder**
- **Supplied complete with power module and 25' of premium microphone power cable**
- **Classic stainless steel design**

Congratulations on your purchase of the Peavey PVM™ T9000. This microphone is sound quality at its finest. The PVM T9000 is a true cardioid microphone, a pattern that effectively rejects "bleed" from other instruments and monitors, which assures that reproduction remains clean and uncolored.

The T9000 is a vacuum tube powered microphone with the tube inside the mic housing. This technique reduces the high impedance of the mic capsule preventing RFI and EMF interference. It's designed specifically for the recording industry where low noise and high performance are demanded. Not only is the T9000 a superb performer, it gives sound engineers the capability of reducing proximity effect, inherent in all cardioid mics, and reducing system overloads by selection of the low cut or -10 dB switch, respectively.

The T9000 is built to last. Its classic stainless steel design will make this microphone one to hold on to for years to come because stainless steel, unlike conventional microphone housings, will not rust and will maintain its appearance for years.

The PVM T9000 comes complete with remote power module, 25 feet of premium microphone power cable, gold-plated connectors, a shock mount, and a swivel adapter. The PVM T9000 is perfect for today's studio environments.

DESCRIPTION OF SYSTEM COMPONENTS

Power Switch

Depress the power switch to the " I " bar symbol to turn the power on. Depress the switch to the " O " position to turn the power off.

IEC Connector



For your safety, we have incorporated a 3-wire line (mains) cable with proper grounding facilities. It is not advisable to remove the ground pin under any circumstances. If it is necessary to use the equipment without proper grounding facilities, suitable grounding adapters should be used. Less noise and greatly reduced shock hazard exists when the unit is operated with proper grounding receptacles.

Power Indicator

The red LED will illuminate indicating power is on.

Microphone Input

Located on the Power Module, it is used to supply the PVM T9000 vacuum tube plate voltage and as a return for the microphone signal.

Balanced Out

A male XLR is used to supply the transformer balanced output signal from the PVM T9000 Power Module.

Clamping Collar

Used to hold the microphone body together. It is also used as a clamping ring for the shock mount.

Architectural & Engineering Specifications

The microphone shall be a permanently polarized, large condenser type employing a back-electret and vacuum tube preamp with a frequency response of from 20 Hz to 20,000 Hz. The microphone shall have a cardioid polar characteristic with a null rear response, which is typically 20 dB down. The microphone shall have an output power level of -40 dB, where 0 dB = 1 mW/Pascal, and a nominal impedance rating of 200 ohms.

The microphone shall have a highly polished stainless steel housing. The output connector shall have a 3-pin male XLR equivalent audio type. The microphone shall include a shock mount, a power module, 25' of microphone power cable, and a swivel adapter for mounting to 5/8" -27 thread. The microphone shall have an overall dimension of 8.035" length and 2.125" diameter. The microphone shall be a Peavey model PVM™ T9000 or equivalent.

SPECIFICATIONS

Enclosure:

Stainless steel

Frequency Response: *(see figure 1)*

20 Hz to 20,000 Hz

Element Type:

Self-biased condenser

Polar Pattern:

Cardioid

Maximum Input Level:

137 dB

High SPL Pad Switch:

-10 dB

Front to Back Rejection: *(see figure 2)*

20 dB (typical)

Low Cut Switch: *(see figure 3)*

200 Hz corner

Impedance:

Low (200 ohms, balanced)

Sensitivity:

Output Power Level:

-40 dB (0 dB = 1 mW/10 microbar)

Open Circuit Voltage:

-56 dB (0 dB = 1 volt/dyne/cm²)

Windscreen:

Stainless steel wire mesh

Microphone Connector:

6-pin male type with gold plated pins

Phasing:

Positive (inward) pressure on diaphragm produces positive voltage at pin #2 on 3-pin male XLR

Shock Mount:

Studio grade with integral heat-sink

Microphone Power Cable:

25' premium cable with gold plated connectors

Power Module Connector:

(1) 6-pin female input

(1) 3-pin male XLR output

Power Requirements:

120 V AC, 15 watts, 60 Hz

Net Weight:

PVM T9000 microphone 1.25 lbs.

Power Module 6.10 lbs.

Cables 1.93 lbs.

Total Net Weight 9.28 lbs.

Shipping Weight:

12.9 lbs.



*Due to our efforts for constant improvements,
features and specifications listed herein are subject to change without notice.*

RESPONSE CURVES

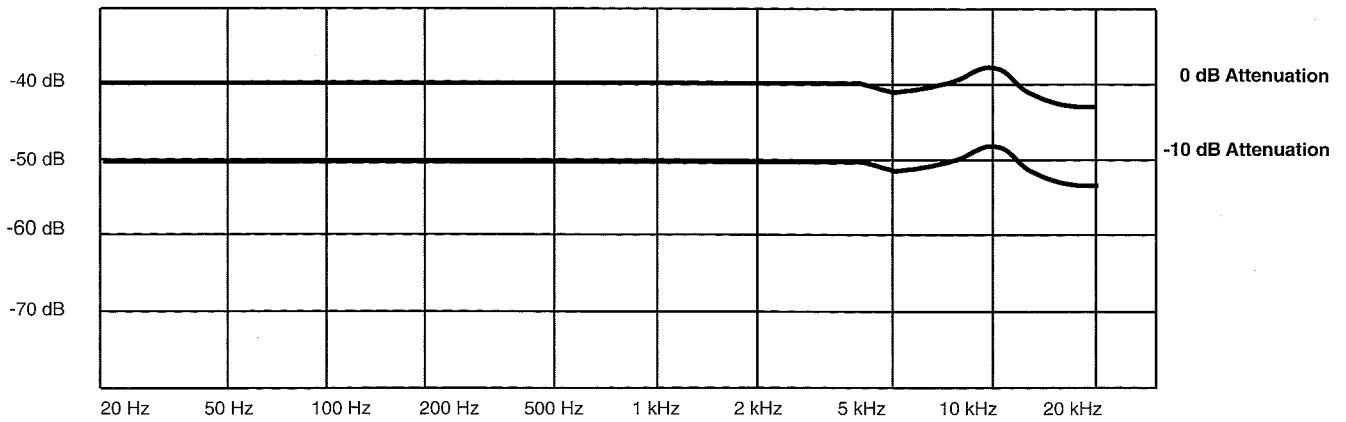

figure 1. Frequency Response

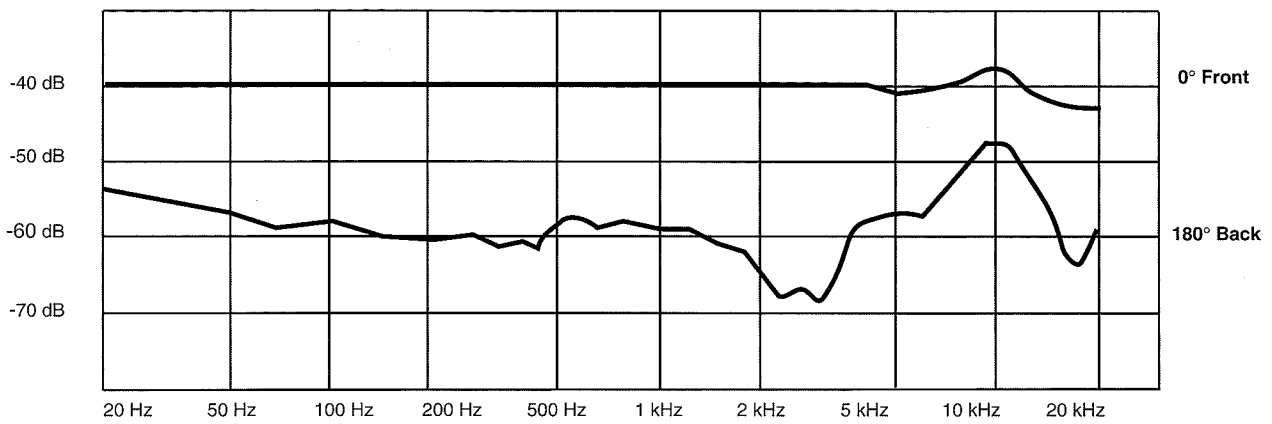

figure 2. Front-to-Back Response

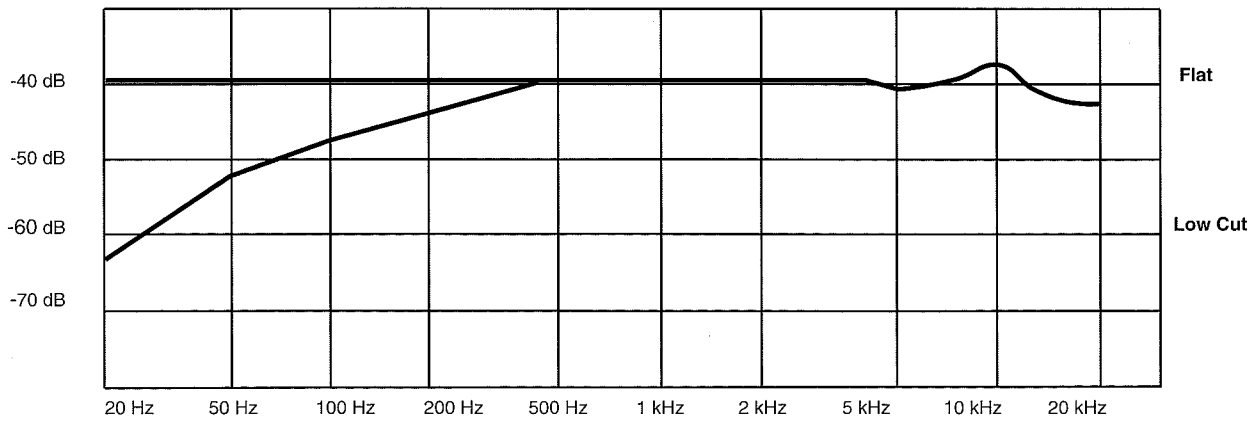
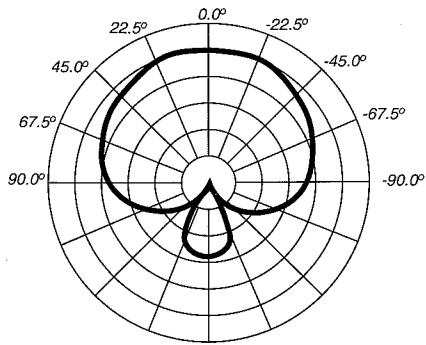

figure 3. Frequency Response with Low Cut Filter

HORIZONTAL POLAR PATTERNS

6 dB per division



500 Hz

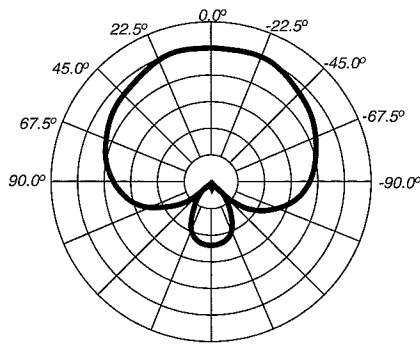

1 kHz

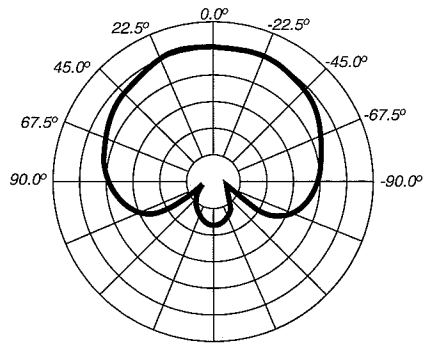

2 kHz

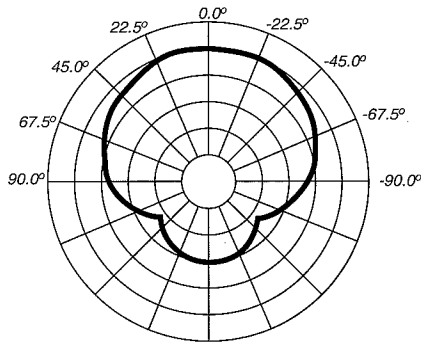

5 kHz

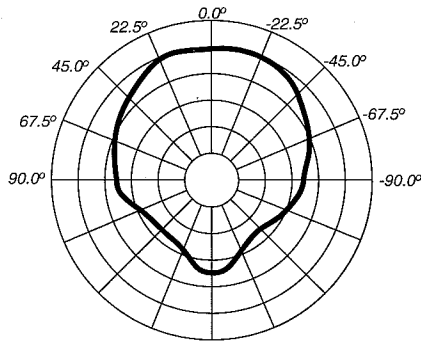

10 kHz

PVM T9000 Dimensions

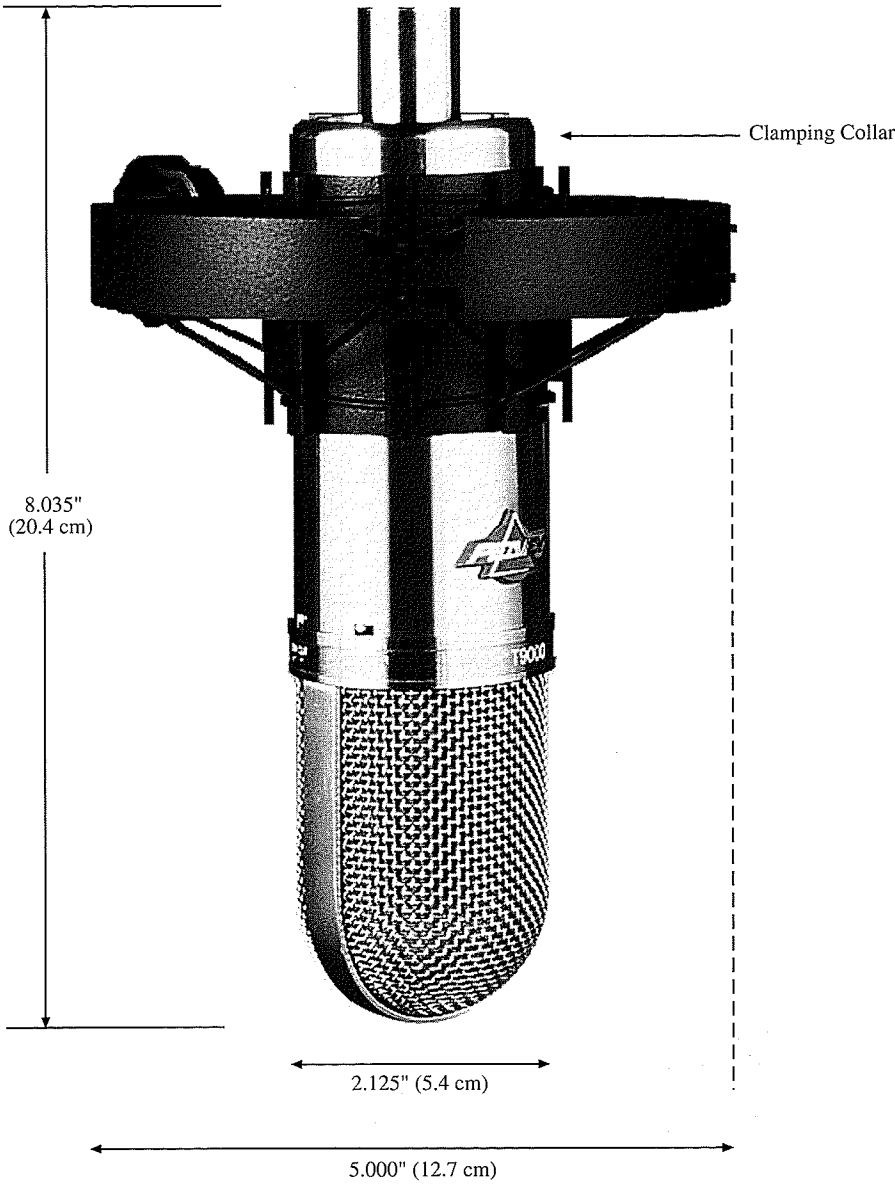

Power Module

Front Panel

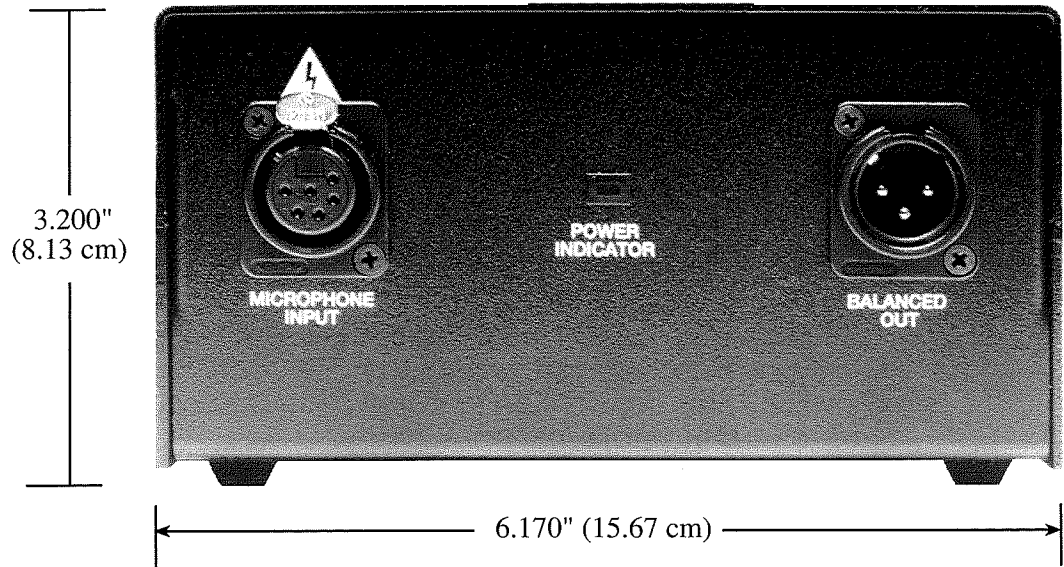

Back Panel



Side Panel

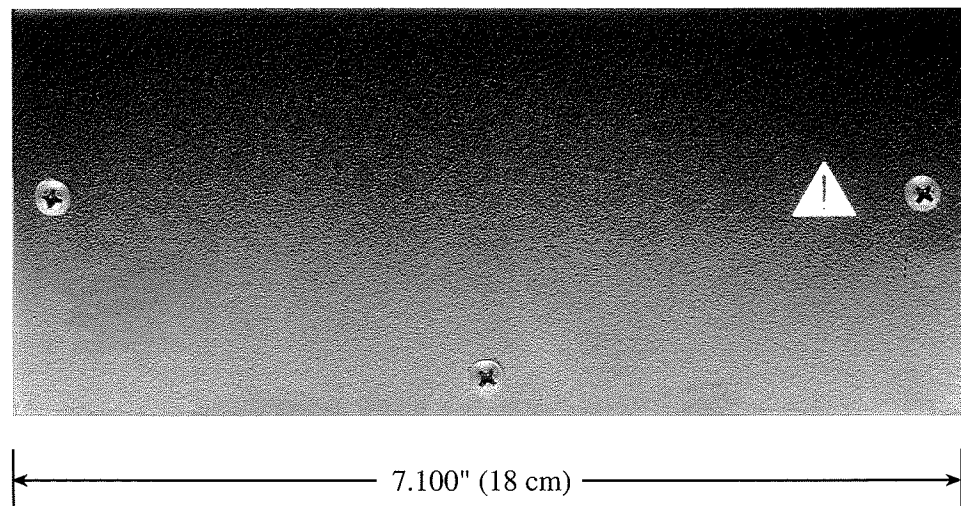

Vacuum Tube Replacement



WARNING: REPLACEMENT OF THE VACUUM TUBE SHOULD BE PERFORMED BY QUALIFIED SERVICE REPAIR PERSONNEL ONLY.

The vacuum tube is located inside the PVM T9000 microphone.

1. Turn power off and disconnect the AC power cord (IEC cable).
2. Disconnect microphone power cable from the PVM T9000.
3. Remove clamping collar from the PVM T9000.



CAUTION: ONCE THE CLAMPING COLLAR IS REMOVED, THE MICROPHONE WILL SLIDE APART EXPOSING THE VACUUM TUBE. BE SURE TO HOLD THE MICROPHONE SCREEN SECURELY BEFORE COMPLETELY REMOVING THE CLAMPING COLLAR.

4. Slide the microphone assembly apart and replace the vacuum tube.
5. Reinsert the microphone assembly paying special attention to the switch positions. A small tab located between the two switches must be aligned with a notch in the stainless-steel housing.
6. Replace the clamping collar and tighten it by hand. Do not over tighten. A good firm hand tightening is sufficient.

IMPORTANT SAFETY INSTRUCTIONS

WARNING: When using electric products, basic cautions should always be followed, including the following:

1. Read all safety and operating instructions before using this product.
2. All safety and operating instructions should be retained for future reference.
3. Obey all cautions in the operating instructions and on the back of the unit.
4. All operating instructions should be followed.
5. This product should not be used near water, i.e., a bathtub, sink, swimming pool, wet basement, etc.
6. This product should be located so that its position does not interfere with its proper ventilation. It should not be placed flat against a wall or placed in a built-in enclosure that will impede the flow of cooling air.
7. This product should not be placed near a source of heat such as a stove, radiator, or heat producing amplifier.
8. Connect only to a power supply of the type marked on the unit adjacent to the power supply cord.
9. Never break off the ground pin on the power supply cord. For more information on grounding, write for our free booklet "Shock Hazard and Grounding."
10. Power supply cords should always be handled carefully. Never walk or place equipment on power supply cords. Periodically check cords for cuts or signs of stress, especially at the plug and the point where the cord exits the unit.
11. The power supply cord should be unplugged when the unit is to be unused for long periods of time.
12. Metal parts can be cleaned with a damp rag. The vinyl covering used on some units can be cleaned with a damp rag or an ammonia-based household cleaner if necessary. Disconnect unit from power supply before cleaning.
13. Care should be taken so that objects do not fall and liquids are not spilled into the unit through the ventilation holes or any other openings.
14. This unit should be checked by a qualified service technician if:
 - a. The power supply cord or plug has been damaged.
 - b. Anything has fallen or been spilled into the unit.
 - c. The unit does not operate correctly.
 - d. The unit has been dropped or the enclosure damaged.
15. The user should not attempt to service this equipment. All service work should be done by a qualified service technician.
16. Exposure to extremely high noise levels may cause a permanent hearing loss. Individuals vary considerably in susceptibility to noise induced hearing loss, but nearly everyone will lose some hearing if exposed to sufficiently intense noise for a sufficient time. The U.S. Government's Occupational Safety and Health Administration (OSHA) has specified the following permissible noise level exposures.

Duration Per Day In Hours	Sound Level dBA, Slow Response
8	90
6	92
4	95
3	97
2	100
1 1/2	102
1	105
1/2	110
1/4 or less	115

According to OSHA, any exposure in excess of the above permissible limits could result in some hearing loss.

Ear plugs or protectors in the ear canals or over the ears must be worn when operating this amplification system in order to prevent a permanent hearing loss if exposure is in excess of the limits as set forth above. To ensure against potentially dangerous exposure to high sound pressure levels, it is recommended that all persons exposed to equipment capable of producing high sound pressure levels such as this amplification system be protected by hearing protectors while this unit is in operation.

SAVE THESE INSTRUCTIONS!

Free Manuals Download Website

<http://myh66.com>

<http://usermanuals.us>

<http://www.somanuals.com>

<http://www.4manuals.cc>

<http://www.manual-lib.com>

<http://www.404manual.com>

<http://www.luxmanual.com>

<http://aubethermostatmanual.com>

Golf course search by state

<http://golfingnear.com>

Email search by domain

<http://emailbydomain.com>

Auto manuals search

<http://auto.somanuals.com>

TV manuals search

<http://tv.somanuals.com>