

# PZ5™ 140

Multi-Zone Mixer/Amplifier





Intended to alert the user to the presence of uninsulated “dangerous voltage” within the product’s enclosure that may be of sufficient magnitude to constitute a risk of electric shock to persons.



Intended to alert the user of the presence of important operating and maintenance (servicing) instructions in the literature accompanying the product.

**CAUTION:** Risk of electrical shock — DO NOT OPEN!

**CAUTION:** To reduce the risk of electric shock, do not remove cover. No user serviceable parts inside. Refer servicing to qualified service personnel.

---

**WARNING:** To prevent electrical shock or fire hazard, do not expose this appliance to rain or moisture. Before using this appliance, read the operating guide for further warnings.



Este símbolo tiene el propósito, de alertar al usuario de la presencia de “(voltaje) peligroso” que no tiene aislamiento dentro de la caja del producto que puede tener una magnitud suficiente como para constituir riesgo de corrientazo.



Este símbolo tiene el propósito de alertar al usuario de la presencia de instrucciones importantes sobre la operación y mantenimiento en la literatura que viene con el producto.

**PRECAUCION:** Riesgo de corrientazo — No abra.

**PRECAUCION:** Para disminuir el riesgo de corrientazo, no abra la cubierta. No hay piezas adentro que el usuario pueda reparar. Deje todo mantenimiento a los técnicos calificados.

---

**ADVERTENCIA:** Para evitar corrientazos o peligro de incendio, no deje expuesto a la lluvia o humedad este aparato. Antes de usar este aparato, lea más advertencias en la guía de operación.



Ce symbole est utilisé pour indiquer à l'utilisateur la présence à l'intérieur de ce produit de tension non-isolée dangereuse pouvant être d'intensité suffisante pour constituer un risque de choc électrique.



Ce symbole est utilisé pour indiquer à l'utilisateur qu'il ou qu'elle trouvera d'importantes instructions sur l'utilisation et l'entretien (service) de l'appareil dans la littérature accompagnant le produit.

**ATTENTION:** Risques de choc électrique — NE PAS OUVRIR!

**ATTENTION:** Afin de réduire le risque de choc électrique, ne pas enlever le couvercle. Il ne se trouve à l'intérieur aucune pièce pouvant être réparée par l'utilisateur. Confier l'entretien à un personnel qualifié.

---

**AVERTISSEMENT:** Afin de prévenir les risques de décharge électrique ou de feu, n'exposez pas cet appareil à la pluie ou à l'humidité. Avant d'utiliser cet appareil, lisez les avertissements supplémentaires situés dans le guide.



Dieses Symbol soll den Anwender vor unisolierten gefährlichen Spannungen innerhalb des Gehäuses warnen, die von Ausreichender Stärke sind, um einen elektrischen Schlag verursachen zu können.



Dieses Symbol soll den Benutzer auf wichtige Instruktionen in der Bedienungsanleitung aufmerksam machen, die Handhabung und Wartung des Produkts betreffen.

**VORSICHT:** Risiko — Elektrischer Schlag! Nicht öffnen!

**VORSICHT:** Um das Risiko eines elektrischen Schlages zu vermeiden, nicht die Abdeckung entfernen. Es befinden sich keine Teile darin, die vom Anwender repariert werden könnten. Reparaturen nur von qualifiziertem Fachpersonal durchführen lassen.

---

**ACHTUNG:** Um einen elektrischen Schlag oder Feuergefahr zu vermeiden, sollte dieses Gerät nicht dem Regen oder Feuchtigkeit ausgesetzt werden. Vor Inbetriebnahme unbedingt die Bedienungsanleitung lesen.

# PZS™ 140

## Multi-Zone Mixer/Amplifier

### DESCRIPTION:

The Peavey Architectural Acoustics PZS™ 140 is a five-channel mixing system with assignment capability to four independent powered zones. Each channel offers low and high equalization, channel level control, and zone assignment switching. Channels one and two offer low-Z (XLR) microphone inputs for paging capability, while channels three through five offer dual (paralleled) RCA jacks for use with various music sources. All five channels also have detachable screw terminal connectors with Low-Z mic inputs and High-Z inputs. Additionally, channels one and two have recessed screwdriver controls for threshold and paging hold time. Each zone has a master level control, signal presence and clipping LED indicators, and detachable connectors for preamp out/power amp in. Each zone power amp is rated at 35 W RMS and provides a 4-ohm direct output and transformer isolated 8-ohm, 25- and 70-volt outputs.

### FEATURES:

- Five input channels
- Four zones
- 35 watts output per zone
- Two XLR low-Z mic inputs (balanced)
- Detachable input connector for Low-Z mic and High-Z line on each channel
- Signal LED indicator for each channel
- Channel level control
- Low and high active EQ for each channel
- Four zone assignment switches for each channel
- Front panel adjustable threshold and paging hold on channels 1 and 2
- Four master output level controls with signal and clipping LED indicators
- Detachable preamp output/power amp input connector for each zone
- 48 volts phantom power on all low-Z inputs
- Each zone output provides a 4-ohms direct output and transformer isolated 8-ohms, 25- and 70-volt outputs
- Each zone has a 600-ohm line level balanced output
- 19" standard rack-mount package
- Three rack spaces
- Externally accessible mains fuse

## FRONT PANEL:

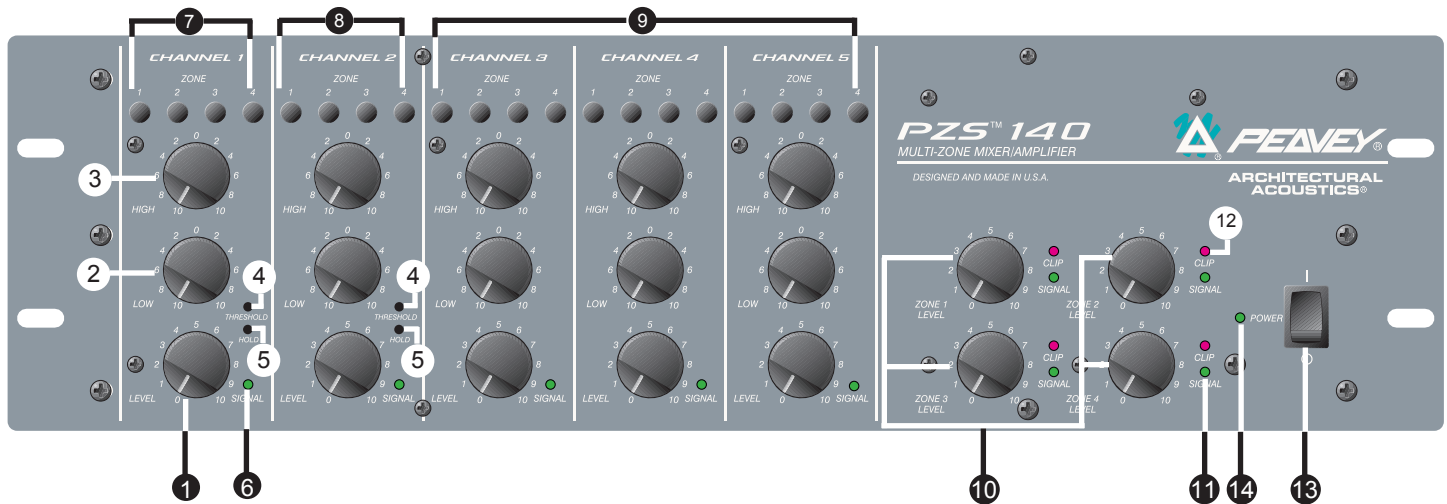

## FRONT PANEL FEATURES:

### 1. CHANNEL 1 LEVEL CONTROLS

Controls the signal level being sent to the assigned zones from each channel.

### 2. CHANNEL LOW EQ CONTROL (BASS)

Active shelving type equalization control that adjusts the channel low-frequency response. Clockwise rotation boosts low frequencies while counter-clockwise rotation reduces low frequencies.

### 3. CHANNEL HIGH EQ CONTROL (TREBLE)

Active shelving type equalization control that adjusts the channel high-frequency response. Clockwise rotation boosts high frequencies while counter-clockwise rotation reduces high frequencies.

### 4. CHANNEL 1 and 2 THRESHOLD CONTROL (SCREWDRIVER)

Controls the level of signal needed to trigger the ducking circuitry in channels 1 and 2. When the ducking circuit is active, the music levels will be reduced by 20 dB to allow the page to be heard. Turning the control clockwise increases the sensitivity of the ducking circuitry. Turning the control completely counter-clockwise defeats the channels' ducking capabilities.

**NOTE:** This control and the channel level control (1) are not related, i.e., the channel level control does not effect the threshold level sensitivity. The threshold control should be set high enough that normal speech into the microphone (paging) will trigger the ducking circuitry, but not so high as to allow the normal room ambient noise level to trigger the ducking circuitry. This usually takes some experimentation and will vary depending upon applications.

### 5. CHANNEL 1 and 2 HOLD CONTROL

Controls the amount of time the signal is held ducked after the page has been completed. Clockwise rotation increases the hold time to a maximum of four seconds. Counter-clockwise rotation decreases the hold time to a minimum of 0.5 seconds. The hold time should be set long enough to prevent the ducked signal from returning to normal levels during a page.

### 6. SIGNAL PRESENCE LED

Green LED that indicates a signal is present in the channel. The signal is sampled directly from the preamp (before the level control) and will illuminate even if the level control is turned completely down. A signal level of -60 dBu or greater in the channel will illuminate this LED.

**7. CHANNEL 1 ZONE ASSIGNMENT SWITCHES**

Switches used to route the signal to the desired zone.

**OPERATION NOTE:** Anytime channel one is assigned to a zone and a signal is present in channel one all other channels assigned to that zone will be ducked by 20 dB. This enables channel one to be used for emergency override signals. This function can be disabled by turning the threshold control completely counter-clockwise.

**8. CHANNEL 2 ZONE ASSIGNMENT SWITCHES**

Switches used to route the signal to the desired zone.

**OPERATION NOTE:** Anytime channel two is assigned to a zone and a signal is present in channel two, all other channels assigned to that zone will be ducked by 20 dB (except channel one). This function can be disabled by turning the threshold control completely counter-clockwise.

**9. CHANNEL 3 THRU 5 ZONE ASSIGNMENT SWITCHES**

Switches used to route the background audio signal to the desired zone. Selecting a particular zone button routes the audio source associated with that particular channel to the desired zone. The zone assignment switches can be used to route the audio to one or more zones if desired.

**10. MASTER ZONE LEVEL CONTROLS**

Controls the signal level being sent to each zone amplifier. Normally these controls should be set at the 12:00 position and the overall system levels set using the various channel level controls. This setting yields the best compromise for system noise performance and signal headroom.

**11. ZONE ACTIVE LEDS**

Indicates whenever any signal activity is occurring in that particular zone. These LEDs will light whenever a signal level above 50 mW RMS occurs in the associated zone power amp. These indicators are helpful for setting up the zone signal levels.

**12. ZONE CLIP LEDS**

Indicates clipping may be occurring in that particular zone. These LEDs will light whenever a signal level of 35 W RMS occurs in the associated zone. If these LEDs occasionally, flash only on peaks of the music or paging signal, audible clipping is probably not occurring. If these LEDs come on and stay on, then the power amps are clipping and audible distortion is probably occurring in that zone.

**OPERATION NOTE:** These LEDs are only an indication of the level being sent to the power amps from the preamp. If a signal processor is used in the insert point, it must be set up in a way that it does not add/reduce the system gain. If the signal processor changes the signal level between the preamp and power amp the LEDs are no longer accurate.

**13. POWER SWITCH**

Rocker type switch, depress to "on" position to power unit.

**14. POWER LED**

Indicates when AC power is being supplied to the unit and the power switch is "on".

## BACK PANEL:

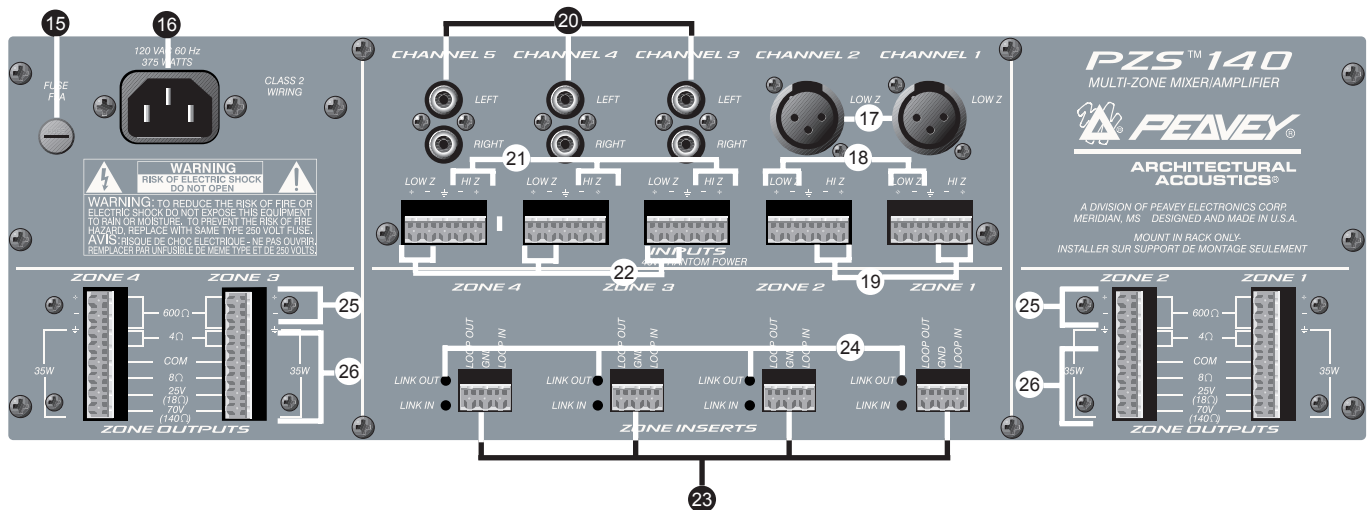

## BACK PANEL FEATURES:

### 15. FUSE



The fuse is located within the cap of fuseholder. If the fuse should fail, IT MUST BE REPLACED WITH ONE OF THE SAME TYPE AND VALUE IN ORDER TO AVOID DAMAGE TO THE EQUIPMENT AND TO PREVENT VOIDING THE WARRANTY. If the amp repeatedly blows fuses, it should be taken to a qualified service for repair.

**WARNING: THE FUSE SHOULD ONLY BE REPLACED WHEN THE POWER CORD HAS BEEN DISCONNECTED FROM ITS POWER SOURCE.**

### 16. AC LINE CORD SOCKET

Provided to accept the removable AC line cord. Connect only to proper source—see back panel markings.

### 17. CHANNEL 1 and 2 XLR INPUTS

Normal low-Z mic inputs for cables fitted with a standard XLR male connector. The circuitry associated with this input is electronically balanced and is designed to accept any normal low impedance microphone. This receptacle is a standard three-pin XLR female wired as follows:  
Pin 1- ground  
Pin 2- positive input  
Pin 3- negative input

**OPERATION NOTE:** 48 volt phantom power is always available on pins 2 and 3 with reference to pin 1.

### 18. CHANNEL 1 and 2 LOW-Z INPUT

Normal low-Z mic inputs for cables without connectors. Two conductor shielded cables should be carefully wired as follows:

Cable shield- GND

Conductor 1- Low-Z positive

Conductor 2- Low-Z negative

Normally conductor 1 should be the positive microphone output feed. If the polarity of the associated microphone is not known, one should be consistent in wiring all mics the same way. Again the circuitry associated with this input is electronically balanced and is designed to accept any normal low-impedance microphone.

**OPERATION NOTE:** 48 volt phantom power is always available on the + and - pins with reference to ground.

**19. CHANNEL 1 and 2 HI-Z INPUT**

Normal high-Z line input for cables without connectors. This high-Z input can be used for normal high impedance unbalanced microphones or other line level feeds. For a balanced application, two conductor shielded cables should be wired as follows:

Cable shield- ground

Conductor 1- Hi-Z positive

Conductor 2- Hi-Z negative.

Notice the ground terminal is shared by the low-Z input as well. Normally, conductor 1 should be the positive output feed from the associated equipment. For unbalanced applications such as microphones with single conductor shielded cables and other such single ended equipment feeds, jumper the Hi-Z negative input to ground, and wire the cable as follows:

Cable shield — ground

Conductor — Hi-Z positive.

**20. CHANNEL 3 THRU 5 RCA INPUTS**

Normal high-Z line inputs for use with cables fitted with RCA male connectors. These inputs are designed to accept normal line level unbalanced signals such as those from a tuner or any other suitable background music source. The dual RCA inputs are mixed together internally to create a mono signal from a stereo feed. If only a mono signal is supplied, then either RCA jack can be used. To create the correct gain structure for the RCA jacks, a new PZS 140 unit has jumpers from the Hi-Z negative input to ground on channels 3-5. If your unit does not have such jumpers in place, and you intend to use the RCA jacks as inputs, it is suggested that you add the jumper to that particular channel.

**21. CHANNEL 3 THRU 5 HI-Z INPUTS**

Normal high-Z line input for cables without connectors. This high-Z input can be used for any line level signal feed, balanced or unbalanced. A new unit has jumpers from the Hi-Z negative input to ground on channels 3- 5. For unbalanced applications such as music sources with single conductor shielded cables, the jumper should be left in place or added. Wire the cable as follows:

Cable shield — ground

Cable conductor — Hi-Z positive.

For balanced signal feeds such as a transformer balanced telephone music feed, the ground jumper should be removed and the two conductor shielded cable should be wired as follows:

Cable shield- ground

Conductor 1- Hi — Z positive

Conductor 2- Hi — Z negative.

**22. CHANNEL 3 THRU 5 LOW-Z INPUTS**

Normal low-Z mic inputs for additional paging microphones as applications warrant. The PZS 140 was primarily designed for two paging microphones and three music sources. If desired, channels 3- 5 can be used for additional mic inputs, although these channels will not duck the music levels as channels 1 and 2 do.

**OPERATION NOTE:** 48 volt phantom power is always available on the + and - pins with reference to ground.

### **23. ZONE LOOP OUT/IN**

A send/return patch point for external effects or EQ. The loop out terminals are line level preamp outputs following the master level stages of each zone. The Loop In terminals are line level power amplifier input points for each zone power amp. Both the Loop Out and Loop In are unbalanced signals requiring only a single conductor shielded cable for patching to the external device. Wire the cables as follows:

Cable shield- ground

Cable conductor-out (or in)

**SEE DRAWINGS page 11.**

**Note:** Both cables share the same ground terminal. The Loop Out has a low source impedance to drive any reasonable device, and the in Loop In is a relatively high impedance input to not load down any reasonable device. It is recommended that all such external effects or EQ devices be in the same rack as the PZS.

### **24. LINK SWITCH**

When the link switch is in the “in” position, the mixer preamp signal is routed directly to the zone power amps. When the link switch is in the “out” position the signal is routed to the Loop Out. This signal can then be sent to an external processor or power amp. If it is sent to an external processor, it can be returned to the Loop In connection to be amplified by the internal zone amplifier.

### **25. 600 OHM BALANCED OUTPUTS**

A balanced output to drive additional power amplifiers. The PZS 140 has four 35 W RMS power amplifiers built in. For small installations, this is an adequate power distribution system, but for larger systems, external power amplifiers may be added to supply the extra power required. In this case, the external power amplifiers can be driven from this 600 ohm balanced line level output without causing unwanted ground loops or hum problems. A two-conductor shielded cable should be wired as follows:

Cable shield- ground

Conductor 1- 600-ohm positive

Conductor 2- 600 ohm negative

In this case, conductor one should be wired to be the positive input feed for the external power amp, and such amp connections can be wired either balanced or unbalanced.

**SEE DRAWINGS page 12.**

### **26. POWER AMP OUTPUTS**

Outputs for speaker connections. Each power amplifier has a 4-ohm direct output, and a transformer isolated 8-ohm, 25- and 70-volt outputs.



# PZS™ 140 SPECIFICATIONS

## POWER OUTPUT:

35 W RMS per channel @ less than 1%  
(60 Hz to 20 kHz with all four channels  
operating)

## OUTPUTS:

4  $\Omega$  (direct), 8  $\Omega$ , 25 V and 70 V (isolated)

## CHANNEL 1 and 2 INPUTS:

Mic: 2k  $\Omega$ , -54 dBu, (1.5 mV, balanced)  
Line: >50k  $\Omega$ , -18 dBu, (100 mV,  
balanced)  
XLR Mic: 2k  $\Omega$ , -54 dBu (1.5 mV, balanced)

## CHANNELS 3 thru 5 INPUTS:

Mic: 2k  $\Omega$ , -54 dBu, (1.5 mV,  
unbalanced)  
Line: >50k  $\Omega$ , -18 dBu (100 mV,  
balanced)  
RCA: >50k  $\Omega$ , -18 dBu, (100 mV,  
unbalanced)

## INSERTS:

Send: 1k  $\Omega$ , 2.21 dBu, (1 volt,  
unbalanced)  
Return: 10k  $\Omega$ , 2.21 dBu, (1 volt  
unbalanced)

## FREQUENCY RESPONSE:

50 Hz to 20 kHz +0, -2 dB (transformer)

## SIGNAL TO NOISE RATIO:

Residual: 90 dB below rated power  
(channel down, master full up)

Line Inputs: 90 dB below rated power  
(controls nominal, 2k  $\Omega$  terminated)

Mic Inputs: 82 dB below rated power  
(controls nominal 150  $\Omega$   
terminated)

## STONE CONTROLS:

Low EQ: +10, -10 dB @ 100 Hz  
High EQ: +10, -10 dB @ 10 kHz

## CONTROLS:

### Channels 1 and 2:

Level, low EQ, high EQ four assign switches,  
signal presence, muting threshold and adjustable  
release time.

### Channels 3 thru 5:

Level, low EQ, high EQ, four assign switches  
and signal presence

### Masters 1 thru 4:

Level, signal presence and clipping LEDs

## POWER SUPPLY:

Internal, 120 V AC @ 60 Hz  
375 watts all channel at full power  
175 watts all channel at 1/8 power  
Five-amp fuse

## DIMENSIONS: (W x H x D)

19" x 6" x 15.25"  
(48.3 cm x 13.3 cm x 38.7)

## WEIGHT:

35.4 pounds (15.6 kg)

# PZS™ 140 Level Diagram

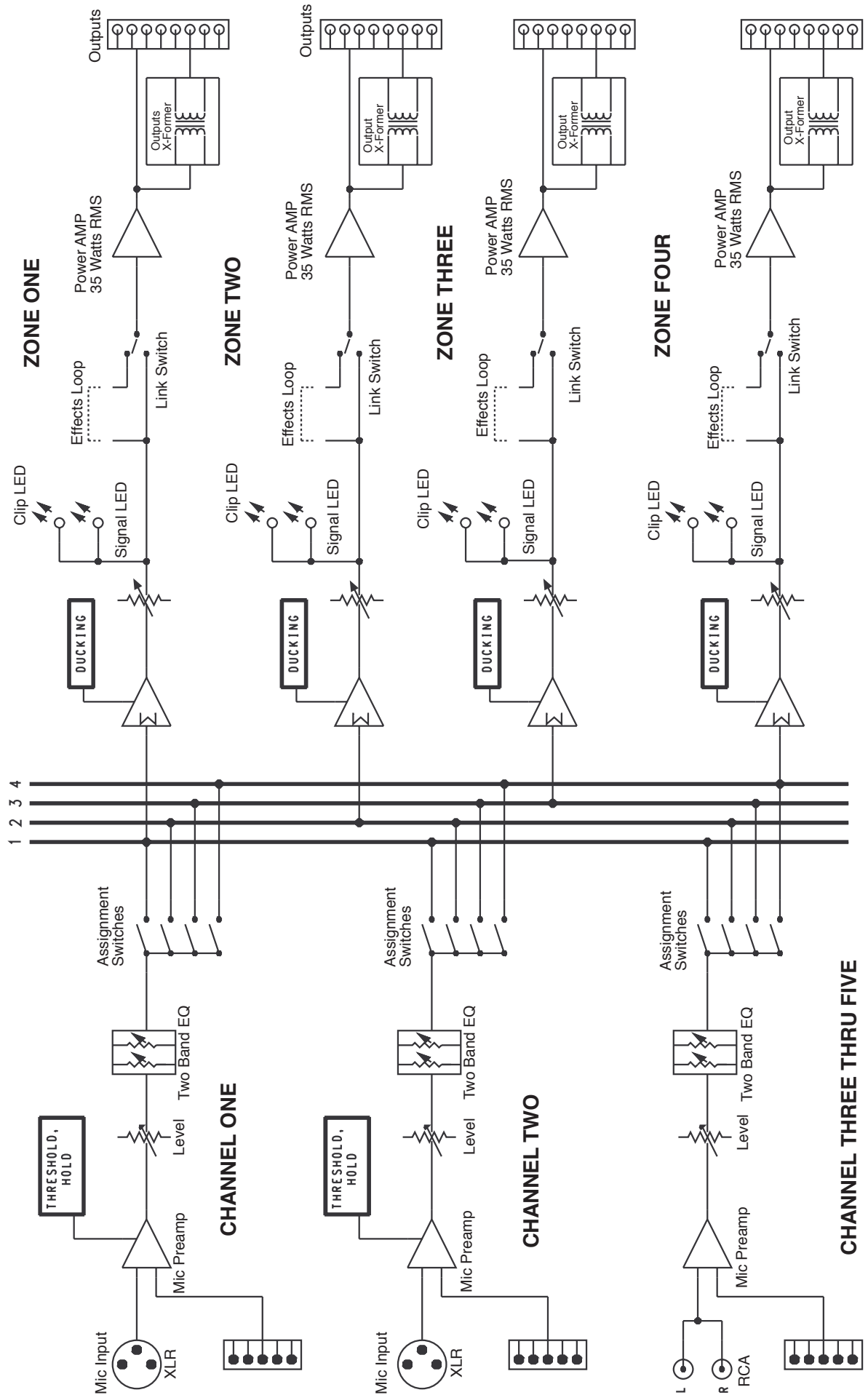

# PZS™ -140 External Power Amp and Effect Patches Output

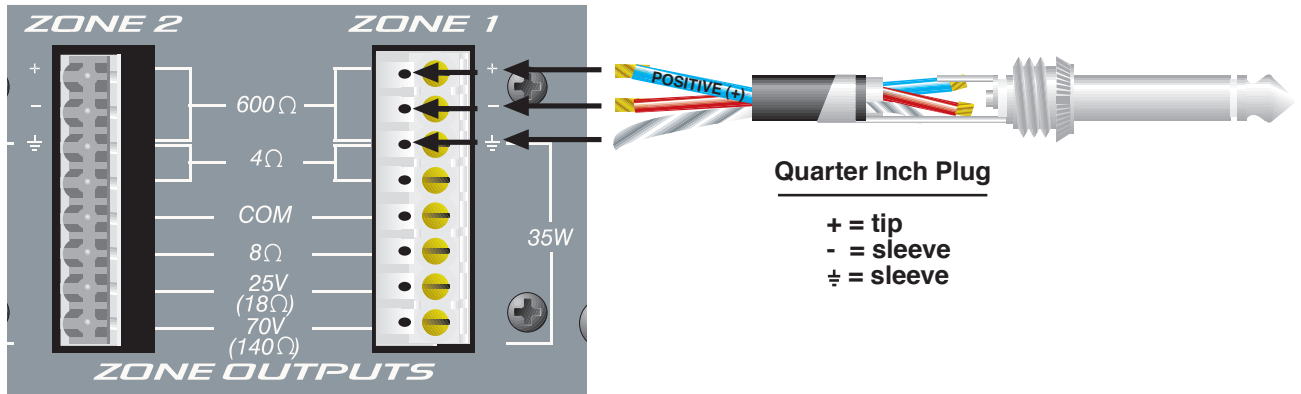

PZS™ 140

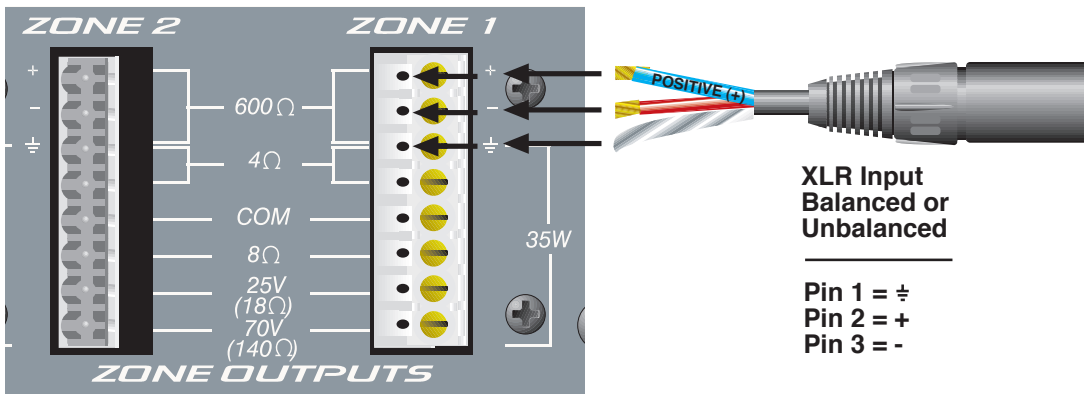

PZS™ 140

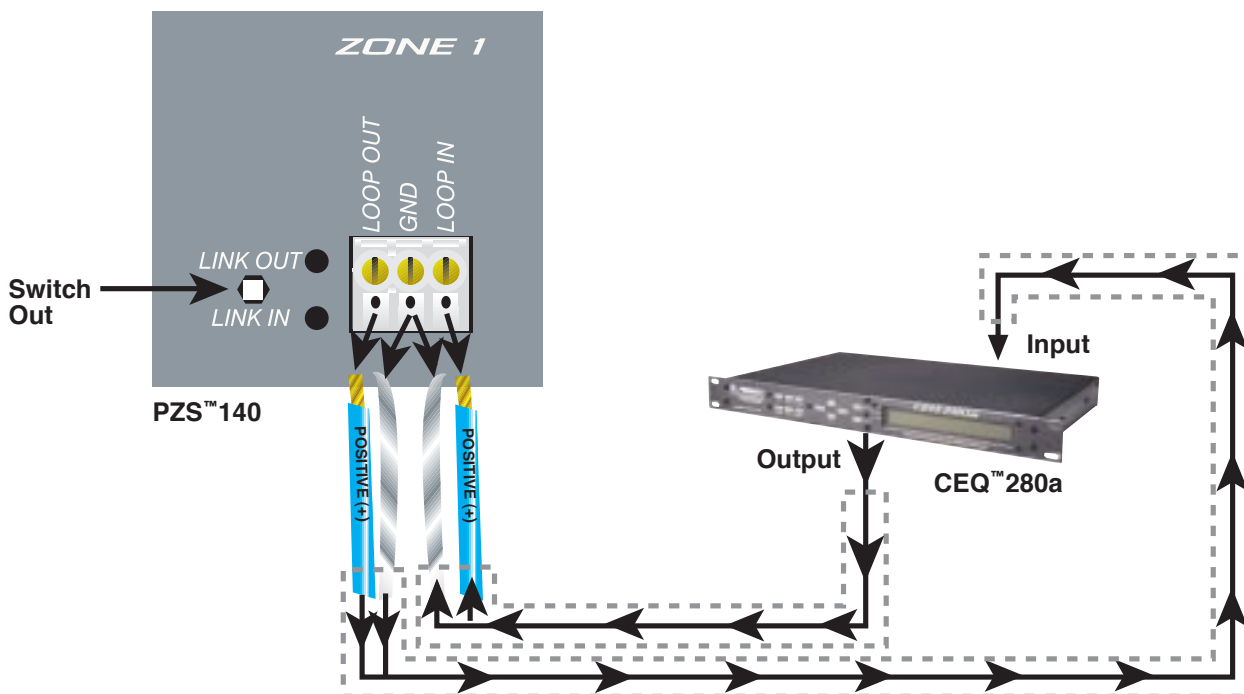

PZS™ 140

CEQ™ 280a

# Typical Small Music/Paging System

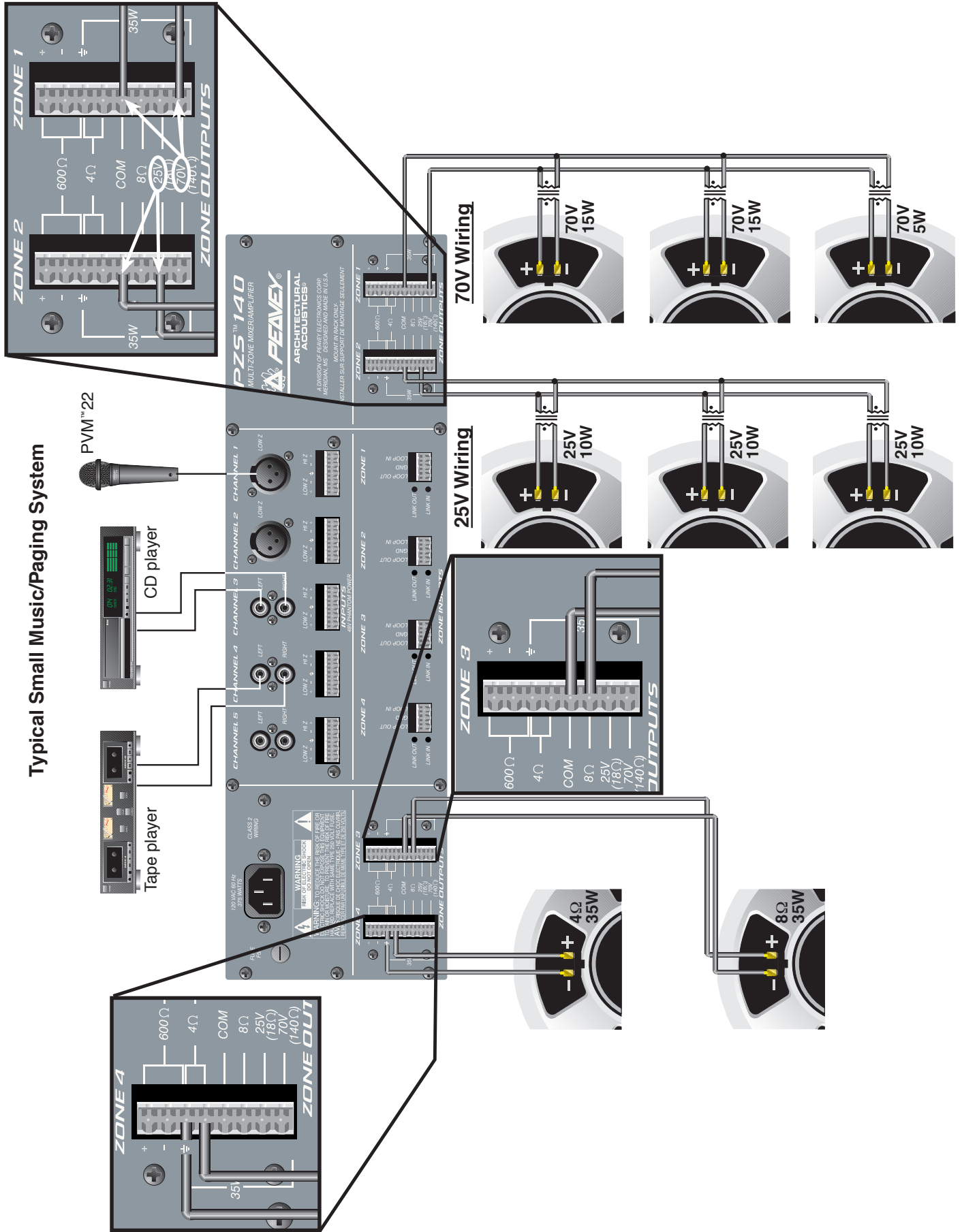

## LIMITED WARRANTY

Peavey Electronics Corporation warrants to the original purchaser of this new Architectural Acoustics product that it is free from defects in material and workmanship. If within one (1) year from date of purchase a properly installed product proves to be defective and Peavey is notified, Peavey will repair or replace it at no charge. (Note: Batteries and patch cords not covered.) "Original purchaser" means the customer for whom the product is originally installed.

Damage resulting from improper installation, interconnection of a unit or system of another manufacturer, accident or unreasonable use, neglect or any other cause not arising from defects in material and workmanship is not covered by this warranty. The warranty is valid only as to products purchased and installed in the United States and Canada.

THIS LIMITED WARRANTY IS IN LIEU OF ANY AND ALL WARRANTIES, EXPRESSED OR IMPLIED, INCLUDING THE IMPLIED WARRANTIES OF MERCHANTABILITY AND FITNESS FOR A PARTICULAR USE. UNDER NO CIRCUMSTANCES WILL PEAVEY BE LIABLE FOR ANY LOST PROFITS, LOST SAVINGS, INCIDENTAL DAMAGES OR CONSEQUENTIAL DAMAGES ARISING OUT OF THE USE OR INABILITY TO USE THE PRODUCT, EVEN IF PEAVEY HAS BEEN ADVISED OF THE POSSIBILITY OF SUCH DAMAGE. THIS LIMITED WARRANTY IS THE ONLY EXPRESSED WARRANTY ON THIS PRODUCT, AND NO OTHER STATEMENT, REPRESENTATION, WARRANTY, OR AGREEMENT BY ANY PERSON SHALL BE VALID OR BINDING UPON PEAVEY.

Peavey's liability to the original purchaser for damages for any cause whatsoever and regardless of the form of action is limited to the actual damages up to the greater of Five Hundred Dollars (\$500) or an amount equal to the purchase price of the product that caused the damage or that is the subject of or is directly related to the cause of action. This limitation of liability will not apply to claims for personal injury or damage to real property or tangible personal property allegedly caused by Peavey's negligence. For information on service under this warranty, call a Peavey customer service representative at (601) 483-5376.

## **Notes:**

## IMPORTANT SAFETY INSTRUCTIONS

**WARNING:** When using electric products, basic cautions should always be followed, including the following:

1. Read all safety and operating instructions before using this product.
2. All safety and operating instructions should be retained for future reference.
3. Obey all cautions in the operating instructions and on the back of the unit.
4. All operating instructions should be followed.
5. This product should not be used near water (i.e., a bathtub, sink, swimming pool, wet basement, etc.)
6. This product should be located so that its position does not interfere with its proper ventilation. It should not be placed flat against a wall or placed in a built-in enclosure that will impede the flow of cooling air.
7. This product should not be placed near a source of heat such as a stove, radiator, or another heat producing amplifier.
8. Connect only to a power supply of the type marked on the unit adjacent to the power supply cord.
9. Never break off the ground pin on the power supply cord. For more information on grounding, write for our free booklet "Shock Hazard and Grounding."
10. Power supply cords should always be handled carefully. Never walk on or place equipment on power supply cords. Periodically check cords for cuts or signs of stress, especially at the plug and the point where the cord exits the unit.
11. The power supply cord should be unplugged when the unit is to be unused for long periods of time.
12. If this product is to be mounted in an equipment rack, rear support should be provided.
13. Metal parts can be cleaned with a damp rag. The vinyl covering used on some units can be cleaned with a damp rag or an ammonia-based household cleaner if necessary. Disconnect unit from power supply before cleaning.
14. Care should be taken so that objects do not fall and liquids are not spilled into the unit through the ventilation holes or any other openings.
15. This unit should be checked by a qualified service technician if:
  - a. The power supply cord or plug has been damaged.
  - b. Anything has fallen or been spilled into the unit.
  - c. The unit does not operate correctly.
  - d. The unit has been dropped or the enclosure damaged.
16. The user should not attempt to service this equipment. All service work should be done by a qualified service technician.
17. This product should be used only with a cart or stand that is recommended by Peavey Electronics.
18. Exposure to extremely high noise levels may cause a permanent hearing loss. Individuals vary considerably in susceptibility to noise induced hearing loss, but nearly everyone will lose some hearing if exposed to sufficiently intense noise for a sufficient time. The U.S. Government's Occupational Safety and Health Administration (OSHA) has specified the following permissible noise level exposures.

Duration Per Day In Hours	Sound Level dBA, Slow Response
8	90
6	92
4	95
3	97
2	100
1 1/2	102
1	105
1/2	110
1/4 or less	115

According to OSHA, any exposure in excess of the above permissible limits could result in some hearing loss. Ear plugs or protectors for the ear canals or over the ears must be worn when operating this amplification system in order to prevent a permanent hearing loss if exposure is in excess of the limits as set forth above. To ensure against potentially dangerous exposure to high sound pressure levels, it is recommended that all persons exposed to equipment capable of producing high sound pressure levels such as this amplification system be protected by hearing protectors while this unit is in operation.

**SAVE THESE INSTRUCTIONS!**



Features and specifications subject to change without notice.



A Division of Peavey Electronics Corporations  
711 A Street / Meridian, MS 39301 / U.S.A. / (601) 486-1678  
Fax (601) 486-1154 .www.peavey.com

©1998



80304445

Printed in U.S.A. 7/98



## Free Manuals Download Website

<http://myh66.com>

<http://usermanuals.us>

<http://www.somanuals.com>

<http://www.4manuals.cc>

<http://www.manual-lib.com>

<http://www.404manual.com>

<http://www.luxmanual.com>

<http://aubethermostatmanual.com>

Golf course search by state

<http://golfingnear.com>

Email search by domain

<http://emailbydomain.com>

Auto manuals search

<http://auto.somanuals.com>

TV manuals search

<http://tv.somanuals.com>