



# XR-400

## OPERATING GUIDE

**CAUTION**  
TO PREVENT ELECTRICAL SHOCK OR FIRE HAZARD, DO NOT EXPOSE THIS INSTRUMENT TO RAIN OR MOISTURE. BEFORE USING THIS INSTRUMENT, READ BACK COVER FOR FURTHER WARNINGS.

### GENERAL DESCRIPTION

The new XR-400 represents our latest effort to combine professional features previously found only in separate mixer/equalizer/power amp components into a single compact and rugged package. The design of the XR-400 utilizes the latest advances in semiconductor technology and the overall circuitry has been designed and optimized by use of the latest computer-aided design techniques. This unit's improved specifications have been made possible by a thorough and complete design effort resulting in all new circuitry from the input jack through to the speaker output.

The XR-400 features four independent input channels and includes a separate "pre" monitor send, active shelving type high and low equalization, and a "post" effects send on each channel. Master level controls are provided for the main, monitor, and reverb return. A full five-band graphic equalizer has been built into the system and utilizes the most contemporary active filter circuitry available. Additional flexibility is provided by the XR-400's patch panel, enabling this versatile unit to be used in conjunction with an extremely wide range of auxiliary equipment.

The 100-watt power amplifier of the XR-400 utilizes four high-voltage, high-speed T0-3 power devices bolted to a massive heatsink. The internal power supply consists of a very large power (mains) transformer featuring a grain oriented silicon steel core and a high degree of magnetic shielding to minimize extraneous hum fields. Silicon rectifiers connected in a full wave bridge feed power to large electrolytic filter banks and provide considerably more music power than the 100-watt RMS power rating would indicate.

Overall, the XR-400 brings professional performance together in an extremely versatile and compact package, offering features and specifications formerly available only with separate components in a single portable package.

### FRONT PANEL

#### INPUT JACKS (A) and (B)

Each channel of the XR-400 is equipped with two input jacks which are connected in a unique circuit that allows a wide range of inputs to be handled. When only one microphone is used, the "A" input jack is more sensitive than the "B" input jack. This high and low gain feature enables optimum microphone matching. If a high output microphone is overloading the sensitive "A" input, simply reconnect this mike into the low gain "B" jack. When two inputs are used in each channel, the input circuit automatically balances to equalize the gain in both A and B jacks. This simple, but effective, switching system gives the user much greater flexibility in choice of input sensitivities and overload protection.

#### CHANNEL CONTROLS

Each of the XR-400's four independent channels contain five controls: Gain, Monitor, Effects and High and Low Equalization.

#### CHANNEL GAIN CONTROL (C)

The channel gain control varies the gain of the input preamplifier. This input preamp is designed around a variable negative feedback approach and provides optimum dynamic range as well as extremely low noise operation. This control is used to set the level of the respective channels to achieve the **main mix**.

#### CHANNEL MONITOR CONTROL (D)

The channel monitor control is a totally **independent** level adjustment used for deriving the proper monitor mix. It is important that the user be aware that this channel monitor send is totally independent from all other channel controls and feeds directly into the monitor buss whose output is determined by the master monitor control (I).

#### CHANNEL EQUALIZATION CONTROLS

The channel equalization controls are of the active "shelving" type and provide 15 dB of boost or cut in their respective frequency ranges. These equalization controls are extremely effective and will allow the user to achieve almost any blend of high's and low's with proper adjustment. Since these EQ controls are capable of a 30 dB range, care should be taken to properly utilize their capabilities. Excessive boosting of low's can cause "muffled" or "boomy" sounds, as well as tending to prematurely overload the power amp because of excessive low frequency power requirements. Overboosting the high's will tend to cause a "strident" or "screechy" tonality, as well as tending to emphasize residual preamp noise and susceptibility to acoustic feedback. Care should be observed when using excessive cut in either frequency range since excessive cutting may degrade the dynamic range capabilities of the input preamp and create poor tonality.

These channel equalization controls have been provided to achieve tonal balance, as well as feedback control in the individual channels for the main mix only. All experimentation should begin with these controls set in the flat "0" (straight up or 12:00) position. Use of the individual channel controls in conjunction with the master graphic equalizer is vital to provide the user with optimum equalization.

#### CHANNEL LOW EQUALIZATION CONTROL (E)

The low equalization control determines whether the low frequencies will be boosted or cut. Boost occurs in the clockwise settings, while cut occurs in the counterclockwise settings. Flat response is obtained in the "0" or vertical position.

#### CHANNEL HIGH EQUALIZATION CONTROL (F)

The high equalization control determines whether the high frequencies will be boosted or cut. Boost occurs in the clockwise settings, while cut occurs in the counterclockwise settings. Flat response is obtained in the "0" or vertical position.

#### CHANNEL EFFECTS CONTROL (G)

The channel effects send control adjusts the signal level applied to the effects mix buss which feeds the internal reverberation system, as well as the effects output on the patch panel. The overall settings of the channel effects send controls determine the amount of reverb drive, as well as the signal output level available from the effects output jack. It is important to note that the effects send control is a "post" type adjustment which is located in the circuit **after** the channel gain and equalization controls. The user should be aware that use of the internal reverberation system can only occur when the channel gain, the channel effects send, the master reverb return and the master gain controls are all properly adjusted.

### MASTER SECTION

The XR-400 master section contains the overall master level control, the master monitor control and the reverb return (to master) control, as well as a five-band graphic equalizer and patch panel. As the name implies, the master controls operate as the final control element for their respective mixing busses and the master graphic EQ determines the final overall equalization.

#### MASTER LEVEL CONTROL (H)

The master level control adjusts the gain of the main mixing buss and determines the level at the main line output jack (Q), as well as determining the signal level applied to the input of the graphic equalizer/power amplifier. It is generally good practice to operate the master level control somewhere in the middle of its operating range to allow maximum flexibility in adjusting overall levels, i.e., it is poor practice to run the individual channel gains way up and the master control way down since this limits the headroom of the input stages and could cause distortion.

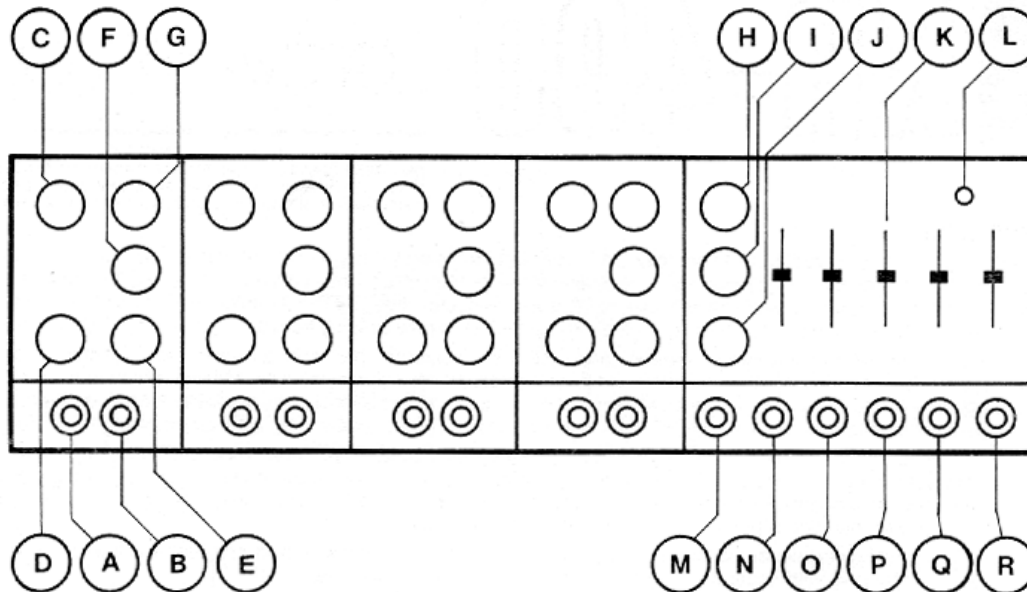

#### MASTER MONITOR LEVEL CONTROL (I)

The master monitor control adjusts the gain of the monitor mixing buss and determines the level of the signal available from the monitor output jack (P). The operation of this control and its independent channel sends is identical to that of the main with the exception that its output is applied to the monitor line output jack instead of the main output jack.

#### MASTER REVERB RETURN CONTROL (J)

The master reverb control determines the amount of delayed signal (reverberation) that is mixed back into the main mix buss. The action of this control (J) is defeated by use of a remote switch being plugged into the footswitch jack (M) located on the patch panel. It is important to note that no reverberation will occur unless the internal delay line is being fed signal from the channel effects send controls. The master reverb return control **does not** affect the level available from the effects output jack located on the patch panel (O).

#### GRAPHIC EQUALIZER (K)

The five-band equalizer is of the latest active type and exhibits performance comparable to that found in the finest commercial equipment. The graphic equalizer is located in the circuit just before the internal 100-watt power amplifier and provides a very versatile and professional equalization of the overall system. Because of the flexibility built into the XR-400, several different modes of operation are possible.

#### NORMAL MODE

Under normal operating conditions (no patch connections), the equalizer is connected through the graphic input switching jack to the main output which is the signal derived from the main mixing buss and controlled by the master gain control.

#### MONITOR OPERATION

The graphic equalizer and internal power amp may be used to power a monitor system by simply patching from the monitor output to the graphic input using a short shielded patch cable. When this patch is accomplished, the signal from the main mixing buss is available **only** at the output jack (P) on the patch panel to be used in conjunction with external power amps, equalizers, or other accessories.

#### MASTER EQUALIZATION

The master graphic equalizer is designed to provide room equalization and overall system tone control. It is important to note that there are no firm operating instructions that will result in the ideal EQ for each and every set of operating conditions. Experimentation with adequate understanding of the graphic equalizer is necessary to achieve optimum results. No amount of equalization will correct an acoustically bad room/mike/speaker arrangement or completely correct the response curve of a poor loudspeaker.

Please make sure that the power amplifier has adequate headroom to handle any boost that may be incurred. If you boost 100 Hz by 3 dB, your power requirement will double. As an example, if your normal performing level requires 100 watts, the power required after a 3 dB equalization boost will be 200 watts.

You should always begin operation with the equalizers in the "0" or center position. It is wise to avoid excessive cutting of large segments of the audio passband since this tends to reduce the dynamic range of the system. Also, it is better to raise the level control rather than to use the majority of the equalizers in the boost position since overall signal-to-noise ratio will result. As with any equalizer device, careful experimentation and a little common sense will yield the desired result.

#### PILOT LED (L)

The pilot LED indicates when the electrical supply is switched on and is actually delivering power to the amplifier.

#### XR-400 PATCH PANEL

The patch panel of the XR-400 has been designed to allow use of auxiliary accessories, mixers, power amps, etc., in conjunction with this unit.

#### FOOTSWITCH JACK (M)

The footswitch jack provides an input to accommodate the optional remote reverb cutoff pedal. This footswitch jack is conventional and should present no operational problems.

#### AUXILIARY INPUT (N)

The auxiliary input provides access to the main mixing buss for patching in signals from external devices such as delay lines or extra mixing channels. Its input impedance is 22K ohms and is designed for signal levels of approximately 1 volt RMS.

#### EFFECTS OUTPUT (O)

The effects output has been designed to deliver output signal from the effects buss for driving various line level devices. Caution should be observed when using accessory devices with the relatively high output signal level available from the effects out. Overall signal level is determined by the setting of the various effects send controls of the respective channels. This output is of relatively low impedance and is capable of approximately 4 volts into 600 ohms or 8 volts into higher load impedances.

## MONITOR OUTPUT (P)

The monitor output provides a signal for an external monitor system and is of relatively low output impedance capable of over 4 volts into 600 ohms or over 8 volts into higher load impedances. The level is controlled by settings of the individual channel monitor sends as well as the master monitor level control.

## MAIN OUTPUT (Q)

The main output provides output from the main mixing buss. This output is of relatively low impedance and is capable of over 4 volts RMS into 600 ohms or over 8 volts into higher load impedances. The output level is determined by the gain and equalization settings of the individual channels, as well as the master gain control.

## GRAPHIC INPUT (R)

The graphic input jack provides a means to allow patching into the internal graphic equalizer / power amp. This jack is of the switching type that normally picks up the signal from the main output jack (Q). When a plug is inserted into the graphic input, the circuit path is broken and this input may now be plugged into other devices or any of the output jacks of the XR-400. The graphic input provides much greater flexibility in allowing the internal graphic / power amp to be utilized as a monitor amp or for any other purpose the user may deem necessary. Its input impedance is approximately 50K ohms at approximately 1-volt signal level for full power output at the speaker jacks.

## REAR PANEL

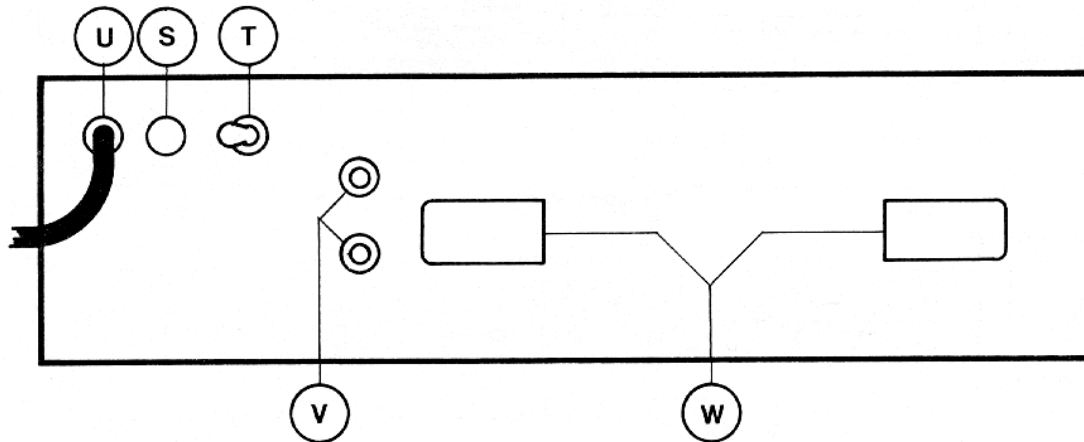

## FUSE (S)

The fuse is located within the cap of the fuseholder. It is necessary that the fuse be replaced with the proper type and value if it should fail in order to avoid damage to the equipment and to prevent voiding the warranty. If your unit repeatedly blows fuses, it should be taken to a qualified service center for repair.

## POWER SWITCH (T)

On domestic units, the power switch is of the three-position type with the center position being "OFF." This switch has two "ON" positions, one of which is used to ground the amplifier properly. One of the "ON" positions will yield the lowest amount of residual hum or "popping" when the instrument is touched and this is the position that should be used.

On export models, we utilize a simple on/off switch that does not have multiple "ON" positions since the grounding (earthing) conditions in most foreign countries are positively made through standard tamper-proof plug-in systems.

## LINE CORD (U)

For your safety, we have incorporated a three-wire line (mains) cable with proper grounding facilities. It is not advisable to remove the ground pin under any circumstances. If it is necessary to use the amp in a two-pin plug system without proper grounding facilities, suitable grounding adaptors should be used. Much less noise and greatly reduced shock hazard exists when the unit is operated with the proper grounded receptacles.

## SPEAKER OUTPUTS (V)

The speaker output jacks are of the standard 1/4" type. Both the output jacks are wired in parallel and either or both may be used when connecting your speaker system. The 200H module has been optimized for a 4-ohm load but has adequate performance to drive loads both above and below the recommended 4-ohm impedance. Extreme care should be used when operating a unit at below 4 ohms since lower load impedances tend to overload the power amplifier and may cause premature activation of the power amp's short circuit protection system and/or thermal fault protection circuitry.

## LINE (MAINS) CORD RETAINER (W)

We have provided two large molded line cord retainers on the rear panel to allow storage of the mains cable for travel. In operation, the cable should be completely unwrapped to allow maximum heat dissipation from the rear panel/heatsink.

### XR-400™ SPECIFICATIONS

#### CHANNELS:

4

#### INPUTS:

8 High Z, 4 being high gain, 4 being padded (-6 dB);  
Graphic input; Auxiliary input

#### SENSITIVITY:

Master, Channel Gain @ Vertical (12:00) setting, All EQ  
flat, 150 mV into High Gain Input for 100 W RMS @  
speaker output into 4 ohms, 42 dB Gain

#### MAXIMUM DYNAMIC RANGE:

3 V RMS @ Jack A 6 V RMS @ Jack B

#### MAXIMUM GAIN:

56 dB with channel Gain full CW 70 dB with channel  
Gain and Main Level full CW

#### INPUT IMPEDANCE:

220K ohms (Jack A) 44K ohms (Jack B)

#### SIGNAL-TO-NOISE RATIO:

Master @ 12:00, All EQ flat, 20 Hz - 20 kHz unweighted;  
1 channel Gain @ 12:00, shorted input, 84 dB  
1 channel Gain @ 12:00, 22K ohms source, 82 dB  
All channel Gains @ 12:00, 22K ohms source, 78 dB

#### CHANNEL EQUALIZATION:

+15 dB @ 80 Hz & 8 kHz, Shelving Characteristic

#### MASTER GRAPHIC EQUALIZATION:

+15 dB @ 100 Hz, 350 Hz, 1 kHz, 3 kHz, and 8 kHz,  
Peak/Notch Characteristic, Average "Q" of 1.5

#### TOTAL SYSTEM FREQUENCY RESPONSE:

+2 dB, 60 Hz - 25 kHz, All EQ flat

#### LINE OUTPUTS:

Main, Monitor, and Effects

#### MAXIMUM OUTPUT:

8 V RMS into 10K ohms (+18 dBV) or 4 V RMS into 600  
ohms (+14 dBm)

#### POWER AMP SPECIFICATIONS

##### RATED POWER:

100 W RMS into 4 ohms load

##### POWER @ CLIPPING:

(1% THD @ 1 kHz, 120 V VAC line). Typically: 80 W RMS  
into 8 ohms; 120 W RMS into 4 ohms; 2 ohm load not  
recommended

##### FREQUENCY RESPONSE:

+0, -1 dB, 30 Hz - 30 kHz, 100 W RMS into 4 ohms

##### TOTAL HARMONIC DISTORTION:

Less than 0.2%, 100 mW to 100 W RMS, 50 Hz - 10 kHz, 4  
ohms, Typically below 0.1%

##### INTERMODULATION DISTORTION:

Less than 0.2%, 100 mW to 100 W RMS, 60 Hz & 5 kHz, 4  
ohms, Typically below 0.1%

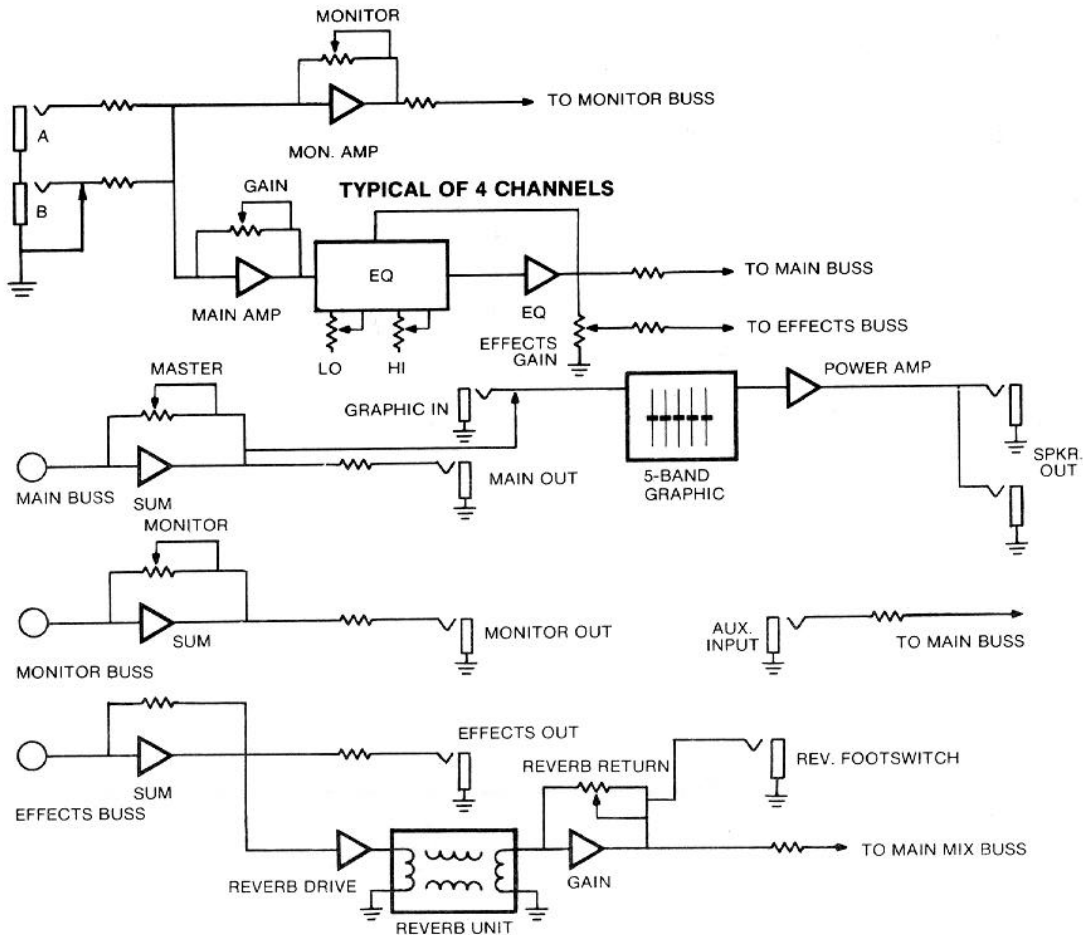

### DANGER

EXPOSURE TO EXTREMELY HIGH NOISE LEVELS MAY CAUSE A PERMANENT HEARING LOSS. INDIVIDUALS VARY CONSIDERABLY IN SUSCEPTIBILITY TO NOISE INDUCED HEARING LOSS, BUT NEARLY EVERYONE WILL LOSE SOME HEARING IF EXPOSED TO SUFFICIENTLY INTENSE NOISE FOR A SUFFICIENT TIME.

THE U.S. GOVERNMENT'S OCCUPATIONAL SAFETY AND HEALTH ADMINISTRATION (OSHA) HAS SPECIFIED THE FOLLOWING PERMISSIBLE NOISE LEVEL EXPOSURES: SOUND LEVEL (dBA, SLOW RESPONSE)

8	90
6	92
4	95
3	97
2	100
1½	102
1	105
½	110
¼ or less	115

ACCORDING TO OSHA, ANY EXPOSURE IN EXCESS OF THE ABOVE PERMISSIBLE LIMITS COULD RESULT IN SOME HEARING LOSS.

EAR PLUGS OR PROTECTORS IN THE EAR CANALS OR OVER THE EARS MUST BE WORN WHEN OPERATING THIS AMPLIFICATION SYSTEM IN ORDER TO PREVENT A PERMANENT HEARING LOSS IF EXPOSURE IS IN EXCESS OF THE LIMITS AS SET FORTH ABOVE. TO INSURE AGAINST POTENTIALLY DANGEROUS EXPOSURE TO HIGH SOUND PRESSURE LEVELS, IT IS RECOMMENDED THAT ALL PERSONS EXPOSED TO EQUIPMENT CAPABLE OF PRODUCING HIGH SOUND PRESSURE LEVELS SUCH AS THIS AMPLIFICATION SYSTEM BE PROTECTED BY HEARING PROTECTORS WHILE THIS UNIT IS IN OPERATION.

### CAUTION

THIS AMPLIFIER HAS BEEN DESIGNED AND CONSTRUCTED TO PROVIDE ADEQUATE POWER RESERVE FOR PLAYING MODERN MUSIC WHICH MAY REQUIRE OCCASIONAL PEAK POWER. TO HANDLE OCCASIONAL PEAK POWER, ADEQUATE POWER "HEADROOM" HAS BEEN DESIGNED INTO THIS SYSTEM. EXTENDED OPERATION AT ABSOLUTE MAXIMUM POWER LEVELS IS NOT RECOMMENDED SINCE THIS COULD DAMAGE THE ASSOCIATED LOUDSPEAKER SYSTEM. PLEASE BE AWARE THAT **MAXIMUM POWER** CAN BE OBTAINED WITH VERY LOW SETTINGS OF THE **GAIN** CONTROLS IF THE INPUT SIGNAL IS VERY STRONG.

1. Read all safety and operating instructions before using this product.
2. All safety and operating instructions should be retained for future reference.
3. Obey all cautions in the operating instructions and on the back of the unit.
4. All operating instructions should be followed.
5. This product should not be used near water, i.e. a bathtub, sink, swimming pool, wet basement, etc.
6. This product should be located so that its position does not interfere with its proper ventilation. It should not be placed flat against a wall or placed in a built-in enclosure that will impede the flow of cooling air.
7. This product should not be placed near a source of heat such as a stove, heater, radiator or another heat producing amplifier.
8. Connect only to a power supply of the type marked on the unit adjacent to the power supply cord.
9. Never break off the ground pin on the power supply cord. For more information on grounding write for our free booklet "Shock Hazard and Grounding."
10. Power supply cords should always be handled carefully. Never walk or place equipment on power supply cords. Periodically check cords for cuts or signs of stress, especially at the plug and the point where the cord exits the unit.
11. The power supply cord should be unplugged when the unit is to be unused for long periods of time.
12. Metal parts can be cleaned with a damp rag. The vinyl covering used on some units can be cleaned with a damp rag, or an ammonia based household cleaner if necessary.
13. Care should be taken so that objects do not fall and liquids are not spilled into the unit through the ventilation holes or any other openings.
14. This unit should be checked by a qualified service technician if:
  - A. The power supply cord or plug has been damaged.
  - B. Anything has fallen or been spilled into the unit.
  - C. The unit does not operate correctly.
  - D. The unit has been dropped or the enclosure damaged.
15. The user should not attempt to service this equipment. All service work should be done by a qualified service technician.



Due to our efforts for constant improvement, specifications are subject to change without notice.

**PEAVEY ELECTRONICS CORP. / 711 A Street / Meridian, MS 39301 / U.S.A.**

©1983 Printed in U.S.A. 10/83 #80322005

## Free Manuals Download Website

<http://myh66.com>

<http://usermanuals.us>

<http://www.somanuals.com>

<http://www.4manuals.cc>

<http://www.manual-lib.com>

<http://www.404manual.com>

<http://www.luxmanual.com>

<http://aubethermostatmanual.com>

Golf course search by state

<http://golfingnear.com>

Email search by domain

<http://emailbydomain.com>

Auto manuals search

<http://auto.somanuals.com>

TV manuals search

<http://tv.somanuals.com>