

BASSIST®

B A S S P R E A M P

E
D
I
U
G
G
N
I
T
R
P
O

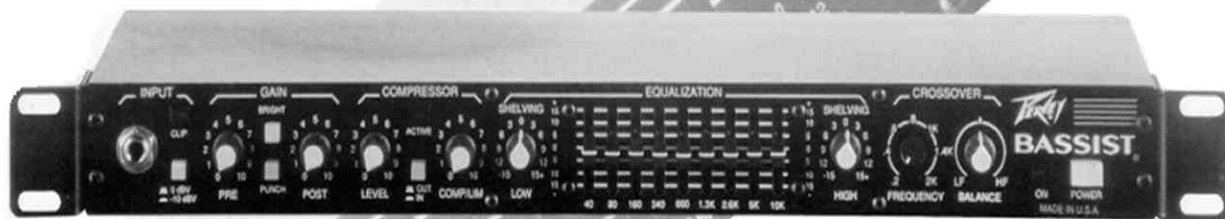



Intended to alert the user to the presence of uninsulated “dangerous voltage” within the product’s enclosure that may be of sufficient magnitude to constitute a risk of electric shock to persons.



Intended to alert the user to the presence of important operating and maintenance (servicing) instructions in the literature accompanying the product.

CAUTION Risks of electrical shock — DO NOT OPEN

CAUTION To reduce the risk of electric shock, do not remove cover. No user serviceable parts inside. Refer Servicing to qualified service personnel.

WARNING To prevent electrical shock or fire hazard, do not expose this appliance to rain or moisture. Before using this appliance, read the operating guide for further warnings.



Este símbolo tiene el propósito de alertar al usuario de la presencia de instrucciones importantes sobre la operación y mantenimiento en la literatura que viene con el producto.



Este símbolo tiene el propósito de alertar al usuario de la presencia de “(voltaje) peligroso” que no tiene aislamiento dentro de la caja del producto que puede tener una magnitud suficiente como para constituir riesgo de corrientazo.

PRECAUCION Riesgo de corrientazo - No abra.

PRECAUCION Para disminuir el riesgo de corrientazo, no abra la cubierta. No hay piezas adentro que el usuario pueda reparar. Deje todo mantenimiento a los técnicos calificados.

ADVERTENCIA Para evitar corrientazos o peligro de incendio, no deje expuesto a la lluvia o humedad este aparato. Antes de usar este aparato, lea más advertencias en la guía de operación.



Ce symbole est utilisé pour indiquer à l'utilisateur qu'il ou qu'elle trouvera d'importantes instructions sur l'utilisation et l'entretien (service) de l'appareil dans la littérature accompagnant le produit.



Ce symbole est utilisé pour indiquer à l'utilisateur la présence à l'intérieur de ce produit de tension non-isolée dangereuse pouvant être d'intensité suffisante pour constituer un risque de choc électrique.

ATTENTION Risques de choc électrique — NE PAS OUVRIR!

ATTENTION Afin de réduire le risque de choc électrique, ne pas enlever le couvercle. Il ne se trouve à l'intérieur aucune pièce pouvant être réparée par l'utilisateur. Confier l'entretien à un personnel qualifié.

AVERTISSEMENT Afin de prévenir les risques de décharge électrique ou de feu, n'exposez pas cet appareil à la pluie ou à l'humidité. Avant d'utiliser cet appareil, lisez les avertissements supplémentaires situés dans le guide d'utilisation.



Dieses Symbol soll den Benutzer auf wichtige Instruktionen in der Bedienungsanleitung aufmerksam machen, die Handhabung und Wartung des Produkts betreffen.



Dieses Symbol soll den Anwender vor unisolierten gefährlichen Spannungen innerhalb des Gehäuses warnen, die von Ausreichender Stärke sind, um einen elektrischen Schlag verursachen zu können.

VORSICHT Risiko - Elektrischer Schlag! Nicht öffnen!

VORSICHT Um das Risiko eines elektrischen Schlages zu vermeiden, nicht die Abdeckung entfernen. Es befinden sich keine Teile darin, die vom Anwender repariert werden könnten. Reparaturen nur von qualifiziertem Fachpersonal durchführen lassen.

ACHTUNG Um einen elektrischen Schlag oder Feuergefahr zu vermeiden, sollte dieses Gerät nicht dem Regen oder Feuchtigkeit ausgesetzt werden. Vor Inbetriebnahme unbedingt die Bedienungsanleitung lesen.

ENGLISH

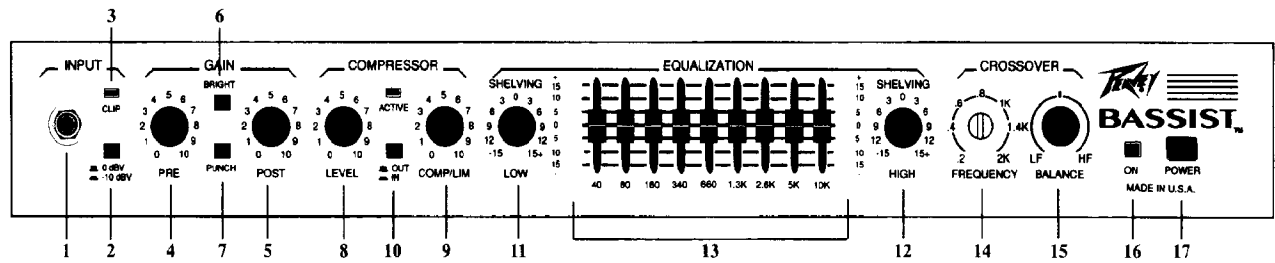

INPUT (1)

This input will accept signals from all types of bass pickups.

INPUT PAD SWITCH (2)

Provided for instruments that have extremely high output, which can result in overdriving (distorting) the input gain stage. Depressing the switch to its “in” position reduces the level of the input signal by 10 dB.

INPUT CLIP INDICATOR (3)

This LED indicates (when lit) that the input gain stage is being overdriven (distorted). Depressing the input pad switch to its “in” position or reducing the pre gain will alleviate this problem.

PRE GAIN (4)

Controls the input gain of the preamplifier.

POST GAIN (5)

Controls the overall volume level of the preamplifier. The final level adjustment should be made after the desired sound has been achieved.

BRIGHT SWITCH (6)

Provides a preset boost (+10 dB) to treble frequencies. To activate, depress the switch to its “in” position.

PUNCH SWITCH (7)

Provides a preset boost (+8 dB) to midbass frequencies. To activate, depress the switch to its “in” position.

LEVEL (8)

Adjusts the output level of the compressor/limiter.

COMP/LIM (9)

Adjusts the amount of compression (compression ratio).

COMPRESSOR ACTIVE SWITCH AND DISPLAY (10)

To activate the compressor, depress the switch to the “in” position. The LED will light when the compressor is active.

LOW (11)

An active tone control (shelving type, ± 15 dB) that varies the low frequency boost or cut.

OPERATIONAL NOTE: Excessive EQ boost, especially of the low frequencies, increases the possibility of speaker damage and sacrifices valuable headroom.

HIGH (12)

An active tone control (shelving type, ± 15 dB) that varies the high frequency boost or cut.

GRAPHIC EQUALIZER (13)

This 9-band, one octave equalizer provides 15 dB of boost or cut at each center frequency.

CROSSOVER FREQUENCY (14)

The frequency control varies the crossover frequency from 200 Hz to 2 kHz.

CROSSOVER BALANCE CONTROL (15)

Controls the relative levels of output signals from the crossover. Adjusting this control will only affect signals at the High Range Output Jack and the Low Range Output Jack on the rear panel. All other output signals are unaffected by this control.

POWER LED (16)

Illuminates when AC power is being supplied to the unit.

POWER SWITCH (17)

Depress the switch to the "on" position. The red pilot light (LED) will illuminate, indicating power is being supplied to the unit.

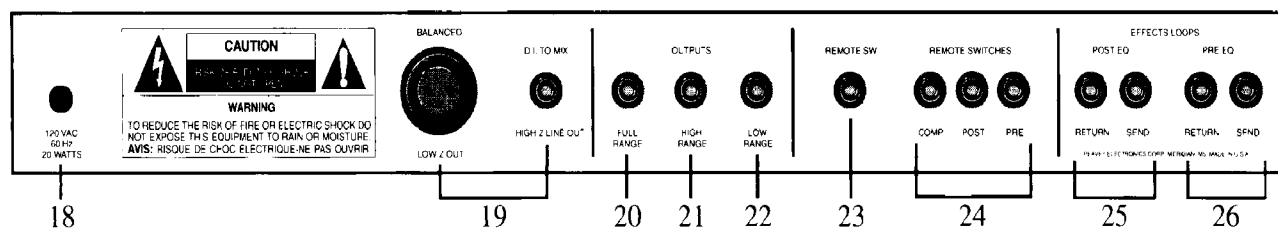

LINE CORD (120 V PRODUCTS ONLY) (18)

For your safety, we have incorporated a 3-wire line (mains) cable with proper grounding facilities. It is not advisable to remove the ground pin under any circumstances. If it is necessary to use the equipment without proper grounding facilities, suitable grounding adaptors should be used. Less noise and greatly reduced shock hazard exists when the unit is operated with the proper grounded receptacles.

LINE OUTPUTS (19)

Balanced XLR (low Z) and unbalanced 1/4" (high Z) jacks are provided. Either can be used to route the signal to mixing/recording consoles. These outputs feature a special EQ to simulate the response of a loudspeaker.

FULL RANGE OUTPUT (20)

Provides a full range signal to drive a power amplifier.

HIGH RANGE OUTPUT (21)

Provides a post crossover high signal to drive a power amplifier.

LOW RANGE OUTPUT (22)

Provides a post crossover low range signal to drive a power amplifier.

REMOTE SWITCH DIN JACK (23)

Provided to use the Peavey footswitch accessory. This three button footswitch controls the compressor/limiter, pre EQ effects loop, and the post EQ effects loop.

REMOTE SWITCHES / 1/4" JACKS (24)

Provided to allow the use of either footswitches that utilize standard 1/4" plugs or automated switching systems that use 1/4" plugs. One 1/4" jack is provided for the compressor/limiter, the pre EQ effects loop and the post EQ effects loop.

POST EQ LOOP (25)

Provided for connecting external effects devices into the signal path. To patch an effects device, connect the send jack to the input of the device. Connect the output of the device to the return jack. High quality shielded cables should be used for these connections.

PRE EQ LOOP (26)

Provided for connecting external effects devices into the signal path. To patch an effects device, connect the send jack to the input of the device. Connect the output of the device to the return jack. High-quality shielded cables should be used for these connections.

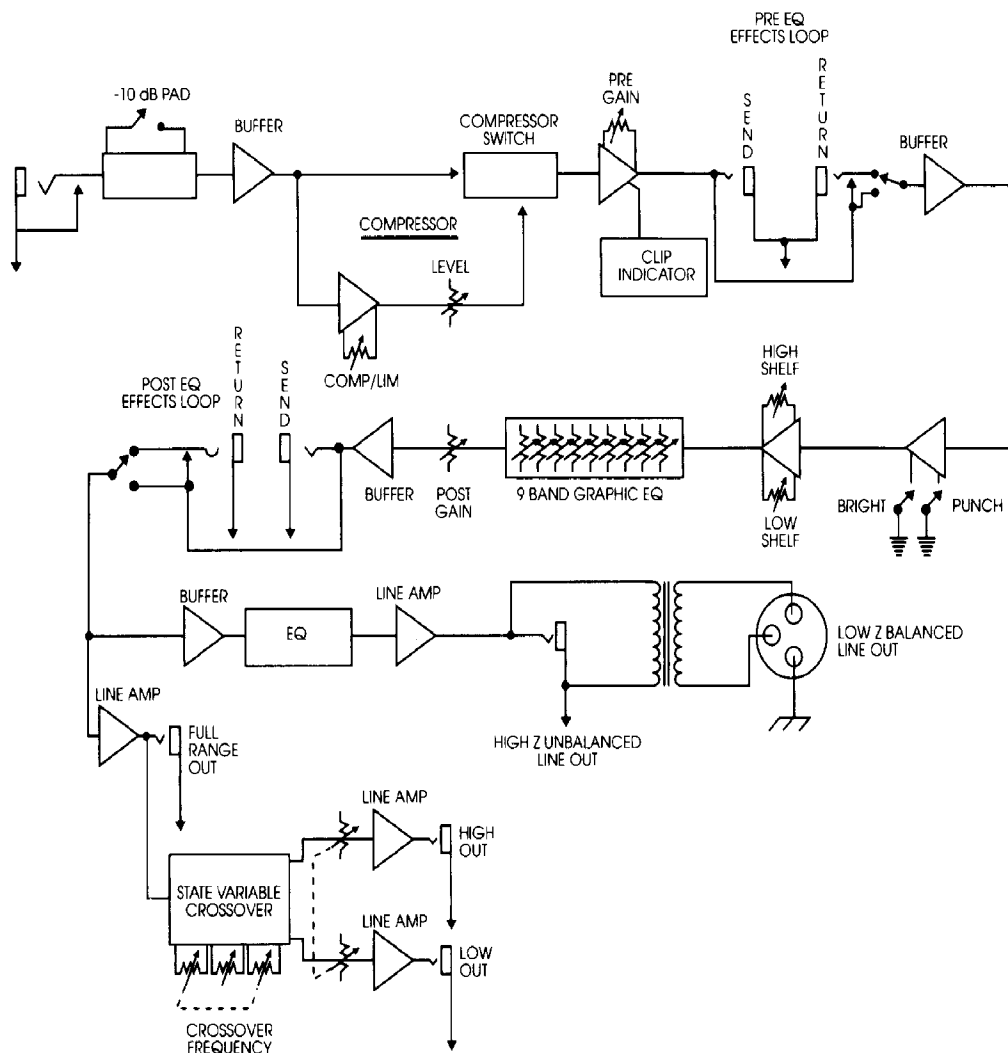

SPECIFICATIONS

The following specs are measured at 1 kHz with the controls set as follows:

Pre Gain at 5
Post Gain at 10
Bright off (out)
Punch off (out)
Low set flat (0)
High set flat (0)
All EQ sliders centered (0)
Nominal levels are with Pre Gain set at 5
Minimum levels are with Pre Gain set at 10
(referenced to 1 V RMS at full range out)

Input Level (Pad Out):

Impedance: Greater than 100 kilohms
Nominal input level: -20 dBV, .10 V RMS
Minimum input level: -41.4 dBV, .0085 V RMS
Maximum input level: +10.4 dBV, 3.3 V RMS

Input Level (Pad In):

Impedance: Greater than 33 kilohms
Nominal input level: -10 dBV, .31 V RMS
Minimum input level: -32 dBV, .025 V RMS
Maximum input level: +20 dBV, 10 V RMS

Pre EQ Effects Loop:

Send:
Function: Low level pre EQ effects send
Output impedance: 100 ohms
Nominal output: -12 dBV, 0.25 V RMS
Maximum output: +8 dBV, 2.5 V RMS

Return:

Function: Low level pre EQ effects return
Input impedance: 22 kilohms
Nominal input: -12 dBV, 0.25 V RMS
Maximum input: +8 dBV, 2.5 V RMS
(Switching jack provides SEND to RETURN connection when not used)

Post EQ Effects Loop:

Send:
Function: Low level pre EQ effects send
Output impedance: 100 ohms
Nominal output: -9 dBV, 0.35 V RMS
Maximum output: +10.9 dBV, 3.5 V RMS

Return:

Function: Low level pre EQ effects return
Input impedance: 90 kilohms
Nominal input: -9 dBV, 0.35 V RMS
Maximum input: +10.9 dBV, 3.5 V RMS
(Switching jack provides SEND to RETURN connection when not used)

Crossover: (For biamp applications)

Range: 200 Hz to 2 kHz
Slope: 18 dB/octave

Outputs:

High Output:
Function: High pass out
Load impedance: 1 kilohms or greater
Nominal output: 0 dBV, 1 V RMS

Maximum output: +20 dBV, 10 V RMS

Low Output:

Function: Low pass out
Load impedance: 1 kilohms or greater
Nominal output: 0 dBV, 1 V RMS
Maximum output: +20 dBV, 10 V RMS

Full Range Output:

Function: Full range output
Load impedance: 1 kilohms or greater
Nominal output: 0 dBV, 1 V RMS
Maximum output: +20 dBV, 10 V RMS

System Hum & Noise: (At nominal input level 20 Hz to 20 kHz unweighted)

100 dB below maximum output

Equalization: (9 band one octave centers with shelving)

40 Hz, 80 Hz, 160 Hz, 340 Hz, 660 Hz, 1.3 kHz, 2.6 kHz, 5 kHz, 10 kHz

All ±15 dB

Low: Active low frequency control, ±15 dB shelving type

High: Active high frequency control, ±15 dB shelving type

Punch: Special low frequency contour, +8 dB

Bright: Special high frequency contour, +10 dB

TONE SETTINGS

ROCK

INPUT: CLIP (0 dBV / -10 dBV)
GAIN: BRIGHT (PRE, PUNCH, POST) [0-10]
COMPRESSOR: ACTIVE (LEVEL, COMP/LIM) [0-10]
EQUALIZATION: SHELVING (LOW, 40, 80, 160, 340, 680, 1.3K, 2.6K, 5K, 10K, HIGH) [0-15]
CROSSOVER: FREQUENCY (1K, 1.4K, 2K, LF, HF) [0-15], BALANCE [ON, POWER]
BASSIST MADE IN U.S.A.

SLAP & POP

INPUT: CLIP (0 dBV / -10 dBV)
GAIN: BRIGHT (PRE, PUNCH, POST) [0-10]
COMPRESSOR: ACTIVE (LEVEL, COMP/LIM) [0-10]
EQUALIZATION: SHELVING (LOW, 40, 80, 160, 340, 680, 1.3K, 2.6K, 5K, 10K, HIGH) [0-15]
CROSSOVER: FREQUENCY (1K, 1.4K, 2K, LF, HF) [0-15], BALANCE [ON, POWER]
BASSIST MADE IN U.S.A.

COUNTRY

INPUT: CLIP (0 dBV / -10 dBV)
GAIN: BRIGHT (PRE, PUNCH, POST) [0-10]
COMPRESSOR: ACTIVE (LEVEL, COMP/LIM) [0-10]
EQUALIZATION: SHELVING (LOW, 40, 80, 160, 340, 680, 1.3K, 2.6K, 5K, 10K, HIGH) [0-15]
CROSSOVER: FREQUENCY (1K, 1.4K, 2K, LF, HF) [0-15], BALANCE [ON, POWER]
BASSIST MADE IN U.S.A.

Tone settings given are general and will vary according to type of guitar, type and gauges of strings, type of pickup and even type of pick. Personal taste, playing style, and type of music greatly contribute to desired tonality.

Consulte los diagramas del panel delantero en la sección de inglés de este manual.

INPUT (Entrada) (1)

Esta entrada aceptará señales de todo tipo de captadora de bajo eléctrico.

INPUT PAD SWITCH (Interruptor atenuante de entrada) (2)

Se suministra para instrumentos que tienen una salida extremadamente alta, la cual puede causar la sobrecarga (distorsión) de la entrada de alta ganancia. El oprimir el interruptor a su posición “hacia dentro”, reduce en 10 dB el nivel de la señal de entrada.

INPUT CLIP INDICATOR (Indicador de recortamiento de señales de entrada) (3)

Este LED indica (al estar iluminado) que está siendo sobreimpulsada (distorsionada) la etapa de ganancia de entrada. Oprimir el interruptor atenuante de entrada a su posición “hacia adentro” o disminuir el control de ganancia previa aliviará este problema.

PRE GAIN (Ganancia previa) (4)

Controla la ganancia de entrada del preamplificador.

POST GAIN (Control de ganancia posterior al preamplificador) (5)

Controla el nivel global de volumen del preamplificador. El ajuste final de nivel debe hacerse una vez que se haya conseguido el sonido deseado.

BRIGHT SWITCH (Interruptor de brillo) (6)

Proporciona un impulso preajustado de +10 dB a las frecuencias agudas. Para activarlo, empuje el interruptor a la posición “hacia dentro”.

PUNCH SWITCH (Interruptor para obtener más impulso) (7)

Provee un aumento de +8 dB a las frecuencias medias graves. Para activar este control empuje hacia dentro.

LEVEL (Nivel) (8)

Este control ajusta el nivel de salida del compresor/limitador.

COMP/LIM (Compresor/limitador) (9)

Este control ajusta la cantidad de compresión (relación de compresión).

COMPRESSOR ACTIVE SWITCH AND DISPLAY (Interruptor e indicador de compresor activo) (10)

Para activar el compresor, ponga el interruptor en la posición “in” (hacia adentro). Quedará iluminado el LED cuando el compresor esté activo.

LOW (Bajo) (11)

Un control de tono activo (tipo “repisa” ± 15 dB) que varía la baja frecuencia, la aumenta o la disminuye.

NOTA: El impulso excesivo del ecualizador, especialmente a las frecuencias graves, aumenta la posibilidad de dañar los altavoces, y sacrifica valiosa gama dinámica.

HIGH (Control de frecuencias agudas) (12)

Un control de tono activo (tipo “repisa” ± 15 dB) que varía el impulso o la reducción de las frecuencias agudas.

GRAPHIC EQUALIZER (Ecualizador gráfico) (13)

Este ecualizador de 9 bandas y una octava proporciona 15 dB de impulso o reducción a cada frecuencia media.

CROSSOVER FREQUENCY (Frecuencia del divisor de frecuencias) (14)

El control de frecuencia varía la frecuencia del divisor de frecuencias desde 200 Hz a 2 kHz.

CROSSOVER BALANCE CONTROL (Control de balance para el divisor de frecuencias) (15)

Controla los niveles relativos de las señales del “crossover” (divisor de frecuencias). Ajustar este control solo afectará las señales en el enchufe hembra de frecuencias agudas y el enchufe hembra de frecuencias graves en la cara posterior. Este control no afecta las demás señales de salida.

POWER LED (LED indicador de corriente) (16)

Se ilumina cuando el equipo recibe la corriente alterna.

POWER SWITCH (Interruptor de corriente) (17)

Oprima el interruptor a la posición “hacia dentro” (encendido). La luz roja del piloto (indicador) se encenderá indicando que la unidad está recibiendo corriente alterna.

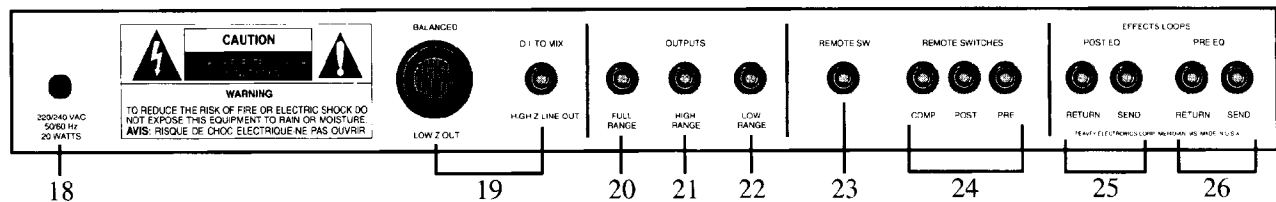

LINE CORD (120 V PRODUCTS ONLY) (Cable de corriente para 120 v solamente) (18)

Para su protección hemos incorporado un cable de 3 polos con polo a tierra. No es recomendable remover la pata del polo a tierra bajo ninguna circunstancia, se recomienda un adaptador en caso necesario. Esto reducirá ruidos y peligrosos corrientazos.

LINE OUTPUTS (Salidas de línea) (19)

Se proporcionan enchufes hembras equilibrados XLR (impedancia baja) y desequilibrados de ¼ de pulgada (impedancia alta). Se puede usar cualquier de los dos para mandar la señal a las consolas de mezcla/grabación. Estas salidas tienen un ecualizador especial para simular la respuesta de un altoparlante.

FULL RANGE OUTPUT (Salida de gama completa) (20)

Esta conexión proporciona una señal de gama completa para impulsar un amplificador de potencia.

HIGH RANGE OUTPUT (Salida de gama alta) (21)

Esta conexión proporciona una señal de gama alta posterior al divisor de frecuencias para impulsar un amplificador de potencia.

LOW RANGE OUTPUT (Salida de gama baja) (22)

Esta conexión proporciona una señal de gama baja posterior al divisor de frecuencias para impulsar un amplificador de potencia.

REMOTE SWITCH DIN JACK (Enchufe hembra din de interruptor remoto) (23)

Este conector se proporciona para usar el interruptor de pedal accesorio de Peavey. Este interruptor de pedal de tres botones controla el compresor/limitador, el lazo de efectos previo al ecualizador y el lazo de efectos posterior a la ganancia.

REMOTE SWITCHES / ¼" JACKS (Interruptores remotos/enchufes hembras de ¼ de pulgada) (24)

Estas conexiones se proporcionan para permitir el uso de interruptores de pedal que utilicen clavijas estándares de ¼ de pulgada o sistemas de interrupción automatizados que utilicen clavijas de ¼ de pulgada. Se proporciona un enchufe hembra de ¼ de pulgada para el compresor/limitador, el lazo de efectos previo al ecualizador y el lazo de efectos posterior al ecualizador.

POST EQ LOOP (Terminales conectores tipo enchufe hembra anteriores al ecualizador) (25)

Estas entradas son para conectar aparatos externos de efectos a la trayectoria de la señal. Para conectar un aparato de efectos, conecte el enchufe hembra de envío a la entrada del aparato. Conecte la salida del aparato al enchufe hembra de retorno. Se deben usar cables blindados de buena calidad para estas conexiones.

PRE EQ LOOP (Terminales conectores tipo enchufe hembra anteriores al ecualizador) (26)

Estas entradas son para conectar aparatos externos de efectos a la trayectoria de la señal. Para conectar un aparato de efectos, conecte el enchufe hembra de envío a la entrada del aparato. Conecte la salida del aparato al enchufe hembra de retorno. Se deben usar cables blindados de buena calidad para estas conexiones.

FRANÇAIS

**Veillez vous référer au “front panel line art”
situé dans la section en langue anglaise de ce manuel.**

INPUT (Entrée) (1)

Cette prise d'entrée accepte les signaux de tous les micros (“pickups”) de basse.

INPUT PAD SWITCH (Atténuateur d'entrée) (2)

Ce poussoir atténue le niveau du signal d'entrée de 10 dB lorsqu'il est enfoncé en position “In”. À utiliser avec les instruments donnant un signal de sortie très élevé qui risque de saturer (distorsion) le stage d'entrée.

INPUT CLIP INDICATOR (Indicateur d'écèlement d'entrée) (3)

Cette DEL indique en s'allumant que le niveau du stade d'entrée est suralimenté (en distorsion). Pour corriger ce problème, amenez le sélecteur du tampon d'entrée («input pad») en position «in» ou réduisez le prégain.

PRE GAIN (4)

Contrôle le gain d'entrée du préamplificateur.

POST GAIN (5)

Commande le volume global de l'preamplificateur. Le réglage final de niveau doit être effectué après avoir obtenu la sonorité désirée à l'aide des autres réglages.

BRIGHT SWITCH (Sélecteur de brillance) (6)

Accentue (10 db) les fréquences aigües. Pour activer, mettre le bouton en position “In”.

PUNCH SWITCH (Sélecteur “Punch”) (7)

Accentue (préréglé à +8 dB) les fréquences moyennes graves. Activer en abaissant l'interrupteur à la position “In”.

LEVEL (Niveau) (8)

Ajuste le niveau de sortie du compresseur/limiteur.

COMP/LIM (9)

Ajuste la profondeur de la compression (ratio de compression).

COMPRESSOR ACTIVE SWITCH AND DISPLAY (Sélecteur et témoin du compresseur) (10)

Presser en position «In» pour activer le compresseur. La DEL s'illumine lorsque le compresseur est en service.

LOW (Graves) (11)

Réglage de tonalité actif (type passe-bas, ± 15 dB), faisant varier l'atténuation ou l'accentuation des fréquences graves.

NOTE: Un renforcement excessif par égalisation, surtout dans les basses fréquences, augmente les risques de dommages aux haut-parleurs, et sacrifie la précieuse réserve de puissance (“headroom”).

HIGH (Aigües) (12)

Réglage de tonalité actif (type passe-haut, ± 15 dB) contrôlant l'atténuation ou l'amplification des fréquences aigües.

GRAPHIC EQUALIZER (Égalisateur graphique) (13)

Cet égalisateur graphique à 9 bandes/une octave coupe ou renforce de 15 dB à chaque fréquence centrale.

CROSSOVER FREQUENCY (Fréquence du filtre) (14)

La commande de fréquence sert à ajuster la fréquence du filtre de division (“crossover”) entre 200 Hz et 2 kHz.

CROSSOVER BALANCE CONTROL (Réglage de balance du filtre) (15)

Ajuste les niveaux relatifs entre les sorties du filtre actif (“crossover”): aigus sur “High Range Output” et graves sur “Low Range Output”. Les autres sorties ne sont pas affectées par ce réglage.

POWER LED (DEL témoin d'alimentation) (16)

S'allume quand l'unité reçoit l'alimentation CA.

POWER SWITCH (Interrupteur d'alimentation) (17)

Mettre l'interrupteur en position “On”. La lampe témoin rouge (DEL) s'illumine indiquant que l'appareil est alimenté en courant.

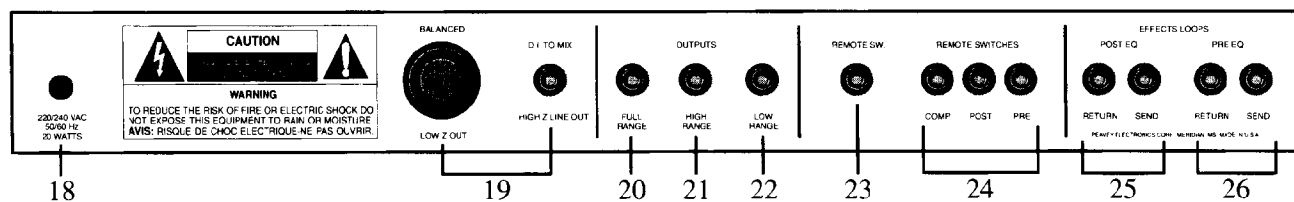

LINE CORD (120V products only) (Cordon d'alimentation pour appareils 120V seulement) (18)

Pour votre sécurité, nous avons incorporé un câble d'alimentation secteur à 3 fils avec mise-à-terre appropriée. Il n'est pas recommandé d'enlever la broche de mise-à-terre en aucune circonstance. S'il est nécessaire d'utiliser l'équipement sans mise-à-terre appropriée, utilisez des adaptateurs de mise-à-terre convenables. Une bonne mise-à-terre amoindrit le bruit de fond et réduit grandement les risques de choc.

LINE OUTPUTS (Sorties ligne) (19)

Prises de sortie équilibrée XLR (basse impédance) et non-équilibrées ¼" (haute impédance) servant à envoyer le signal à un pupitre de mélange/enregistrement. Une égalisation spéciale est utilisée pour simuler la réponse de haut-parleurs de puissance.

FULL RANGE OUTPUT (Sortie plein registre) (20)

Sortie de signal plein registre servant à alimenter un amplificateur de puissance.

HIGH RANGE OUTPUT (Sortie aigus) (21)

Fournit un signal de registre aigu post filtre (“post-crossover”) pouvant alimenter un amplificateur de puissance.

LOW RANGE OUTPUT (Sortie de registre grave) (22)

Fournit un signal de registre grave post filtre (“post-crossover”) pouvant alimenter un amplificateur de puissance.

REMOTE SWITCH DIN JACK (Prise DIN pour interrupteur à distance) (23)

Permet d'utiliser l'accessoire Peavey Footswitch. Cet interrupteur au pied à trois boutons commande le compresseur/limiteur, la boucle d'effets pré-EQ et la boucle d'effets post-gain.

REMOTE SWITCHES / ¼" JACKS (Prises ¼" pour interrupteur à distance) (24)

Permet d'utiliser un interrupteur au pied muni de fiches standard ¼" ou un système de sélection automatique utilisant des fiches standard ¼". Une prise ¼" est fournie pour le compresseur/limiteur, la boucle d'effets pré-EQ et la boucle d'effets post-gain.

POST EQ LOOP (Prise boucle d'effets après égalisation) (25)

Prises pour insertion d'un appareil d'effets externe dans le cheminement du signal. Pour brancher un appareil d'effets, branchez la prise "Send" à l'entrée de l'appareil. Branchez la sortie de l'appareil à la prise "Return". Utilisez des câbles blindés de haute-qualité pour ces connexions.

PRE EQ LOOP (Prises pour boucle d'effets avant égalisation) (26)

Prises servant à insérer un appareil d'effets externe dans le cheminement du signal. Pour brancher un appareil d'effets, branchez la sortie "Send" à l'entrée de l'appareil. Branchez la sortie de l'appareil à l'entrée "Return". Utilisez des câbles blindés de haute-qualité pour ces connexions.

Siehe Diagramm der Frontplatte im englischen Teil des Handbuchs.

INPUT (Eingang) (1)

Dieser Eingang verarbeitet das Signal sämtlicher Bass-Pickups.

INPUT PAD SWITCH (Eingangs-Absenkungs-Schalter) (2)

Wird für instrumente mit extrem hohem Ausgangs-Pegel verwendet, damit die Vorverstärker-Stufe nicht übersteuert wird, was zu Verzerrungen führen würde. Bei eingedrücktem Schalter wird das Eingangssignal um 10 dB abgesenkt.

INPUT CLIP INDICATOR (Input clip anzeige) (3)

Dieses LED zeigt beim Aufleuchten an, daß das Eingangssignal übersteuert (verzerrt) wird. Drücken des Input Schalters in die "in" Position oder Zurücknehmen des Pre Gain löst dieses Problem.

PRE GAIN (4)

Regelt die Eingangsempfindlichkeit des Vorverstärkers.

POST GAIN (5)

Kontrolliert die Gesamtlautstärke des Verstärkers. Die engültige Lautstärke sollte erst eingestellt werden, wenn der gewünschte Sound erreicht ist.

BRIGHT SWITCH (6)

Besorgt einen voreingestellten Schub (+10 dB) in den hohen Frequenzen. Zur Aktivierung den Knopf in die "In"-Position drücken.

PUNCH SWITCH (Punch-Schalter) (7)

Bewirkt eine voreingestellte Anhebung um 8 dB im Bassbereich. Wird bei eingedrücktem Schalter ("In") aktiviert.

LEVEL (8)

Regelt den Ausgangspegel des Compressor/Limiters.

COMP/LIM (9)

Regelt den Grad der Kompression (Compression Ratio).

COMPRESSOR ACTIVE SWITCH AND DISPLAY (Kompressor aktivschalter und anzeige) (10)

Um den Kompressor einzuschalten, Schalter in die "in" Position bringen. Das LED leuchtet, wenn der Kompressor in Betrieb ist.

LOW (11)

Eine aktive Klangregelung (± 15 dB) zur Anhebung oder Absenkung der tiefen Frequenzen.

MERKE: Der übermäßige Boost des EQ, besonders im tiefen Bereich, erhöht die Gefahr, die Lautsprecher zu zerstören und geht auf Kosten des "Headrooms".

HIGH (12)

Eine aktive Klangregelung (± 15 dB) zur Anhebung oder Absenkung der hohen Frequenzen.

GRAPHIC EQUALIZER (13)

Dieser 9-Band 1-Oktave Equalizer bietet 15 dB Anhebung oder Absenkung an der Mittelstellung, der sog. Centerfrequenz.

CROSSOVER FREQUENCY (14)

Der Frequenzregler variiert die Trennfrequenz von 200 Hz bis 2 kHz.

CROSSOVER BALANCE CONTROL (Frequenzweichen-Balance) (15)

Bestimmt das Verhältnis der Ausgangs-Pegel der Frequenzweiche. Nur die Signale über die rückseitigen Jack-Anschlüsse "High Range Output" und "Low Range Output" werden beeinflusst. Alle anderen Ausgänge bleiben unverändert.

POWER LED (16)

Ist erleuchtet, wenn das Gerät eingeschaltet ist und mit Strom versorgt wird.

POWER SWITCH (Netzschalter) (17)

Bringen Sie den Schalter auf die ON-Position. Die rote Kontrolllampe (LED) leuchtet und zeigt an, daß das Gerät eingeschaltet ist.

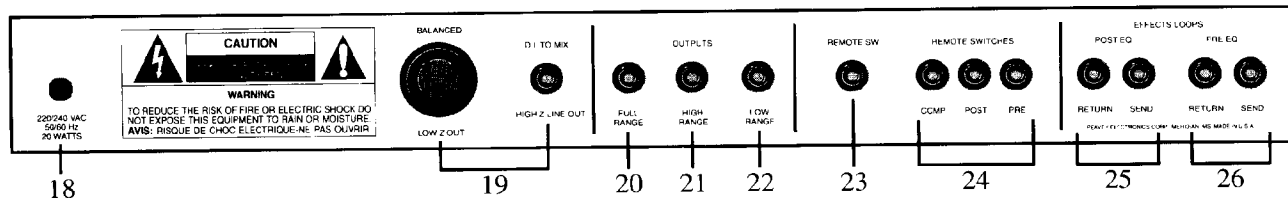

LINE CORD (120V products only) (Nur bei 120 Volt-Geräten) (18)

Zu Ihrer Sicherheit haben wir das Gerät mit einem dreiadrigen geerdeten Netzkabel versehen. Es ist unter keinen Umständen empfehlenswert den Erdungskontakt des Anschlußkabels zu lösen. Falls es notwendig sein sollte, das Equipment ohne die vorgesehene Erdung zu betreiben empfiehlt sich die Verwendung eines Grounding Adaptors. Die geringsten Störgeräusche und die höchste Sicherheit vor elektrischen Schlägen wird jedoch durch die Benutzung der vorgesehenen Erdungsmöglichkeiten erreicht.

LINE OUTPUTS (19)

Hier stehen symmetrische XLR- und unsymmetrische Klinkenbuchsen zur Verfügung. Beide können dazu verwendet werden, das Signal zum Mischpult oder Aufnahmegerät zu leiten. Diese Ausgänge verfügen über ein spezielles EQ zur Simulation der Reaktion eines Lautsprechers.

FULL RANGE OUTPUT (20)

Bietet ein Breitbandsignal zur Betreibung einer Endstufe.

HIGH RANGE OUTPUT (21)

Bietet ein nach dem Crossover abgegriffenes Hochfrequenzsignal zur Betreibung einer Endstufe.

LOW RANGE OUTPUT (22)

Bietet ein nach dem Crossover abgegriffenes Tieffrequenzsignal zur Betreibung einer Endstufe.

REMOTE SWITCH DIN JACK (Fußschalter DIN busche) (23)

Hier kann der Peavey Fußschalter angeschlossen werden. Die drei Knöpfe dieses Fußschalters regeln den Compressor/Limiter, den Pre EQ Effektweg und den Post Gain Effektweg.

REMOTE SWITCHES / ¼" JACKS (Fußschalter klinken busche) (24)

Hier können Fußschalter angeschlossen werden, die über Standard Klinkenstecker verfügen oder automatisch umschaltende Systeme, die mit Standard Klinkensteckern arbeiten. Eine Klinkenbuchse steht für den Compressor/Limiter zur Verfügung, den Pre EQ Effektweg und den Post Gain Effektweg.

POST EQ LOOP (Post-EQ-Einschlaufpunkt) (25)

Ermöglicht das Einschlaufen von externen Effekten in den Signalfluss. Der "Send"-Jack muss mit dem Eingang des Effekt-Geräts verbunden werden, und der Ausgang des Effekt-Geräts mit dem "Return"-Jack. Für diese Verbindungen sollten nur hochwertige, gut abgeschirmte Kabel verwendet werden.

PRE EQ LOOP (Pre-EQ-Einschleifpunkt) (26)

Ermöglicht das Einschleifen von externen Effekten in den Signalfluss. Der "Send"-Jack muss mit dem Eingang des Effekt-Geräts verbunden werden, und der Ausgang des Effekt-Geräts mit dem "Return"-Jack. Für diese Verbindungen sollten nur hochwertige, gut abgeschirmte Kabel verwendet werden.

THIS LIMITED WARRANTY VALID ONLY WHEN PURCHASED AND REGISTERED IN THE UNITED STATES OR CANADA. ALL EXPORTED PRODUCTS ARE SUBJECT TO WARRANTY AND SERVICES TO BE SPECIFIED AND PROVIDED BY THE AUTHORIZED DISTRIBUTOR FOR EACH COUNTRY.

Ces clauses de garantie ne sont valables qu'aux Etats-Unis et au Canada. Dans tout les autres pays, les clauses de garantie et de maintenance sont fixees par le distributeur national et assuree par lui seion la legislation envigueur.

Diese Garantie ist nur in den USA und Kanada gultig. Alle Export-Produkte sind der Garantie und dem Service des Importeurs des jewelligen Landes unterworfen. Esta garantia es valida solamente cuando el producto es comprado en E.U. continentales o en Canada. Todos los productos que sean comprados en el extranjero, estan sujetos a las garantias y servicio que cada distribuidor autorizado determine y ofrezca en los diferentes paises.

**PEAVEY ONE-YEAR LIMITED
WARRANTY/REMEDY**

PEAVEY ELECTRONICS CORPORATION ("PEAVEY") warrants this product, EXCEPT for covers, footswitches, patchcords, tubes and meters, to be free from defects in material and workmanship for a period of one (1) year from date of purchase. PROVIDED, however, that this limited warranty is extended only to the original retail purchaser and is subject to the conditions, exclusions, and limitations hereinafter set forth:

PEAVEY 90-DAY LIMITED WARRANTY ON TUBES AND METERS

If this product contains tubes or meters, Peavey warrants the tubes or meters contained in the product to be free from defects in material and workmanship for a period of ninety (90) days from date of purchase; PROVIDED, however, that this limited warranty is extended only to the original retail purchaser and is also subject to the conditions, exclusions, and limitations hereinafter set forth.

CONDITIONS, EXCLUSIONS, AND LIMITATIONS OF LIMITED WARRANTIES

These limited warranties shall be void and of no effect, if:

- a. The first purchase of the product is for the purpose of resale; or
- b. The original retail purchase is not made from an AUTHORIZED PEAVEY DEALER; or
- c. The product has been damaged by accident or unreasonable use, neglect, improper service or maintenance, or other causes not arising out of defects in material or workmanship; or
- d. The serial number affixed to the product is altered, defaced, or removed.

In the event of a defect in material and/or workmanship covered by this limited warranty, Peavey will:

- a. In the case of tubes or meters, replace the defective component without charge.
- b. In other covered cases (i.e., cases involving anything other than covers, footswitches, patchcords, tubes or meters), repair the defect in material or workmanship or replace the product, at Peavey's option; and provided, however, that, in any case, all costs of shipping, if necessary, are paid by you, the purchaser.

THE WARRANTY REGISTRATION CARD SHOULD BE ACCURATELY COMPLETED AND MAILED TO AND RECEIVED BY PEAVEY WITHIN FOURTEEN (14) DAYS FROM THE DATE OF YOUR PURCHASE.

In order to obtain service under these warranties, you must:

- a. Bring the defective item to any PEAVEY AUTHORIZED DEALER or AUTHORIZED PEAVEY SERVICE CENTER and present therewith the ORIGINAL PROOF OF PURCHASE supplied to you by the AUTHORIZED PEAVEY DEALER in connection with your purchase from him of this product. If the DEALER or SERVICE CENTER is unable to provide the necessary warranty service you will be directed to the nearest other PEAVEY AUTHORIZED DEALER or AUTHORIZED PEAVEY SERVICE CENTER which can provide such service.

OR

- b. Ship the defective item, prepaid, to:

PEAVEY ELECTRONICS CORPORATION
International Service Center
326 Hwy. 11 & 80 East
MERIDIAN, MS 39301

including therewith a complete, detailed description of the problem, together with a legible copy of the original PROOF OF PURCHASE and a complete return address. Upon Peavey's receipt of these items:

If the defect is remedial under these limited warranties and the other terms and conditions expressed herein have been complied with, Peavey will provide the necessary warranty service to repair or replace the product and will return it, FREIGHT COLLECT, to you, the purchaser.

Peavey's liability to the purchaser for damages from any cause whatsoever and regardless of the form of action, including negligence, is limited to the actual damages up to the greater of \$500.00 or an amount equal to the purchase price of the product that caused the damage or that is the subject of or is directly related to the cause of action. Such purchase price will be that in effect for the specific product when the cause of action arose. This limitation of liability will not apply to claims for personal injury or damage to real property or tangible personal property allegedly caused by Peavey's negligence. Peavey does not assume liability for personal injury or property damage arising out of or caused by a non-Peavey alteration or attachment, nor does Peavey assume any responsibility for damage to interconnected non-Peavey equipment that may result from the normal functioning and maintenance of the Peavey equipment.

UNDER NO CIRCUMSTANCES WILL PEAVEY BE LIABLE FOR ANY LOST PROFITS, LOST SAVINGS, ANY INCIDENTAL DAMAGES, OR ANY CONSEQUENTIAL DAMAGES ARISING OUT OF THE USE OR INABILITY TO USE THE PRODUCT, EVEN IF PEAVEY HAS BEEN ADVISED OF THE POSSIBILITY OF SUCH DAMAGES.

THESE LIMITED WARRANTIES ARE IN LIEU OF ANY AND ALL WARRANTIES, EXPRESSED OR IMPLIED, INCLUDING, BUT NOT LIMITED TO, THE IMPLIED WARRANTIES OF MERCHANTABILITY AND FITNESS FOR A PARTICULAR USE; PROVIDED, HOWEVER, THAT IF THE OTHER TERMS AND CONDITIONS NECESSARY TO THE EXISTENCE OF THE EXPRESSED, LIMITED WARRANTIES, AS HEREINABOVE STATED, HAVE BEEN COMPLIED WITH, IMPLIED WARRANTIES ARE NOT DISCLAIMED DURING THE APPLICABLE ONE-YEAR OR NINETY-DAY PERIOD FROM DATE OF PURCHASE OF THIS PRODUCT.

SOME STATES DO NOT ALLOW LIMITATION ON HOW LONG AN IMPLIED WARRANTY LASTS, OR THE EXCLUSION OR LIMITATION OF INCIDENTAL OR CONSEQUENTIAL DAMAGES. SO THE ABOVE LIMITATIONS OR EXCLUSIONS MAY NOT APPLY TO YOU. THESE LIMITED WARRANTIES GIVE YOU SPECIFIC LEGAL RIGHTS, AND YOU MAY ALSO HAVE OTHER RIGHTS WHICH MAY VARY FROM STATE TO STATE.

THESE LIMITED WARRANTIES ARE THE ONLY EXPRESSED WARRANTIES ON THIS PRODUCT, AND NO OTHER STATEMENT, REPRESENTATION, WARRANTY, OR AGREEMENT BY ANY PERSON SHALL BE VALID OR BINDING UPON PEAVEY.

In the event of any modification or disclaimer of expressed or implied warranties, or any limitation of remedies, contained herein conflicts with applicable law, then such modification, disclaimer or limitation, as the case may be, shall be deemed to be modified to the extent necessary to comply with such law.

Your remedies for breach of these warranties are limited to those remedies provided herein and Peavey Electronics Corporation gives this limited warranty only with respect to equipment purchased in the United States of America.

INSTRUCTIONS — WARRANTY REGISTRATION CARD

1. Mail the completed WARRANTY REGISTRATION CARD to:

PEAVEY ELECTRONICS CORPORATION
POST OFFICE BOX 2898
MERIDIAN, MISSISSIPPI 39302-2898

- a. Keep the PROOF OF PURCHASE. In the event warranty service is required during the warranty period, you will need this document. There will be no identification card issued by Peavey Electronics Corporation.
2. IMPORTANCE OF WARRANTY REGISTRATION CARDS AND NOTIFICATION OF CHANGES OF ADDRESSES:
 - a. Completion and mailing of WARRANTY REGISTRATION CARDS — Should notification become necessary for any condition that may require correction, the REGISTRATION CARD will help ensure that you are contacted and properly notified.
 - b. Notice of address changes — If you move from the address shown on the WARRANTY REGISTRATION CARD, you should notify Peavey of the change of address so as to facilitate your receipt of any bulletins or other forms of notification which may become necessary in connection with any condition that may require dissemination of information or correction.
3. You may contact Peavey directly by telephoning (601) 483-5365.

IMPORTANT SAFETY INSTRUCTIONS

WARNING: When using electric products, basic cautions should always be followed, including the following.

1. Read all safety and operating instructions before using this product.
2. All safety and operating instructions should be retained for future reference.
3. Obey all cautions in the operating instructions and on the back of the unit.
4. All operating instructions should be followed.
5. This product should not be used near water, i.e., a bathtub, sink, swimming pool, wet basement, etc.
6. This product should be located so that its position does not interfere with its proper ventilation. It should not be placed flat against a wall or placed in a built-in enclosure that will impede the flow of cooling air.
7. This product should not be placed near a source of heat such as a stove, radiator, or another heat producing amplifier.
8. Connect only to a power supply of the type marked on the unit adjacent to the power supply cord.
9. Never break off the ground pin on the power supply cord. For more information on grounding, write for our free booklet "Shock Hazard and Grounding."
10. Power supply cords should always be handled carefully. Never walk or place equipment on power supply cords. Periodically check cords for cuts or signs of stress, especially at the plug and the point where the cord exits the unit.
11. The power supply cord should be unplugged when the unit is to be unused for long periods of time.
12. If this product is to be mounted in an equipment rack, rear support should be provided.
13. Metal parts can be cleaned with a damp rag. The vinyl covering used on some units can be cleaned with a damp rag or an ammonia-based household cleaner if necessary. Disconnect unit from power supply before cleaning.
14. Care should be taken so that objects do not fall and liquids are not spilled into the unit through the ventilation holes or any other openings.
15. This unit should be checked by a qualified service technician if:
 - a. The power supply cord or plug has been damaged.
 - b. Anything has fallen or been spilled into the unit.
 - c. The unit does not operate correctly.
 - d. The unit has been dropped or the enclosure damaged.
16. The user should not attempt to service this equipment. All service work should be done by a qualified service technician.
17. This product should be used only with a cart or stand that is recommended by Peavey Electronics.
18. Exposure to extremely high noise levels may cause a permanent hearing loss. Individuals vary considerably in susceptibility to noise induced hearing loss, but nearly everyone will lose some hearing if exposed to sufficiently intense noise for a sufficient time. The U.S. Government's Occupational Safety and Health Administration (OSHA) has specified the following permissible noise level exposures.

Duration Per Day In Hours	Sound Level dBA, Slow Response
8	90
6	92
4	95
3	97
2	100
1 1/2	102
1	105
1/2	110
1/4 or less	115

According to OSHA, any exposure in excess of the above permissible limits could result in some hearing loss.

Ear plugs or protectors in the ear canals or over the ears must be worn when operating this amplification system in order to prevent a permanent hearing loss if exposure is in excess of the limits as set forth above. To ensure against potentially dangerous exposure to high sound pressure levels, it is recommended that all persons exposed to equipment capable of producing high sound pressure levels such as this amplification system be protected by hearing protectors while this unit is in operation.

SAVE THESE INSTRUCTIONS!



Features and specifications subject to change without notice.

Peavey Electronics Corporation 711 A Street / Meridian, MS 39301 / U.S.A. / (601) 483-5365 / Fax 486-1278

©1995

#80301701

Printed in U.S.A. 1/95

Free Manuals Download Website

<http://myh66.com>

<http://usermanuals.us>

<http://www.somanuals.com>

<http://www.4manuals.cc>

<http://www.manual-lib.com>

<http://www.404manual.com>

<http://www.luxmanual.com>

<http://aubethermostatmanual.com>

Golf course search by state

<http://golfingnear.com>

Email search by domain

<http://emailbydomain.com>

Auto manuals search

<http://auto.somanuals.com>

TV manuals search

<http://tv.somanuals.com>