



## Pro Comm® PCX™ -U1002 Wireless Receiver

---

Operating  
Manual



---

[www.peavey.com](http://www.peavey.com)



Intended to alert the user to the presence of uninsulated “dangerous voltage” within the product’s enclosure that may be of sufficient magnitude to constitute a risk of electric shock to persons.



Intended to alert the user of the presence of important operating and maintenance (servicing) instructions in the literature accompanying the product.

**CAUTION:** Risk of electrical shock — DO NOT OPEN!

**CAUTION:** To reduce the risk of electric shock, do not remove cover. No user serviceable parts inside. Refer servicing to qualified service personnel.

**WARNING:** To prevent electrical shock or fire hazard, this apparatus should not be exposed to rain or moisture, and objects filled with liquids, such as vases, should not be placed on this apparatus. Before using this apparatus, read the operating guide for further warnings.

ENGLISH



Este símbolo tiene el propósito, de alertar al usuario de la presencia de “(voltaje) peligroso” sin aislamiento dentro de la caja del producto y que puede tener una magnitud suficiente como para constituir riesgo de descarga eléctrica.



Este símbolo tiene el propósito de alertar al usuario de la presencia de instrucciones importantes sobre la operación y mantenimiento en la información que viene con el producto.

**PRECAUCION:** Riesgo de descarga eléctrica ¡NO ABRIR!

**PRECAUCION:** Para disminuir el riesgo de descarga eléctrica, no abra la cubierta. No hay piezas útiles dentro. Deje todo mantenimiento en manos del personal técnico cualificado.

**ADVERTENCIA:** Para prevenir choque eléctrico o riesgo de incendios, este aparato no se debe exponer a la lluvia o a la humedad. Los objetos llenos de líquidos, como los floreros, no se deben colocar encima de este aparato. Antes de usar este aparato, lea la guía de funcionamiento para otras advertencias.

ESPAÑOL



Ce symbole est utilisé dans ce manuel pour indiquer à l'utilisateur la présence d'une tension dangereuse pouvant être d'amplitude suffisante pour constituer un risque de choc électrique.



Ce symbole est utilisé dans ce manuel pour indiquer à l'utilisateur qu'il ou qu'elle trouvera d'importantes instructions concernant l'utilisation et l'entretien de l'appareil dans le paragraphe signalé.

**ATTENTION:** Risques de choc électrique — NE PAS OUVRIR!

**ATTENTION:** Afin de réduire le risque de choc électrique, ne pas enlever le couvercle. Il ne se trouve à l'intérieur aucune pièce pouvant être réparée par l'utilisateur. Confiez l'entretien et la réparation de l'appareil à un réparateur Peavey agréé.

**AVIS:** Dans le but de réduire les risques d'incendie ou de décharge électrique, cet appareil ne doit pas être exposé à la pluie ou à l'humidité et aucun objet rempli de liquide, tel qu'un vase, ne doit être posé sur celui-ci. Avant d'utiliser de cet appareil, lisez attentivement le guide fonctionnant pour avertissements supplémentaires.

FRANÇAIS



Dieses Symbol soll den Anwender vor unisolierten gefährlichen Spannungen innerhalb des Gehäuses warnen, die von Ausreichender Stärke sind, um einen elektrischen Schlag verursachen zu können.



Dieses Symbol soll den Benutzer auf wichtige Instruktionen in der Bedienungsanleitung aufmerksam machen, die Handhabung und Wartung des Produkts betreffen.

**VORSICHT:** Risiko — Elektrischer Schlag! Nicht öffnen!

**VORSICHT:** Um das Risiko eines elektrischen Schlages zu vermeiden, nicht die Abdeckung entfernen. Es befinden sich keine Teile darin, die vom Anwender repariert werden könnten. Reparaturen nur von qualifiziertem Fachpersonal durchführen lassen.

**WARNUNG:** Um elektrischen Schlag oder Brandgefahr zu verhindern, sollte dieser Apparat nicht Regen oder Feuchtigkeit ausgesetzt werden und Gegenstände mit Flüssigkeiten gefüllt, wie Vasen, nicht auf diesen Apparat gesetzt werden. Bevor dieser Apparat verwendet wird, lesen Sie bitte den Funktionsführer für weitere Warnungen.

DEUTSCH

## IMPORTANT SAFETY INSTRUCTIONS

ENGLISH

**WARNING:** When using electrical products, basic cautions should always be followed, including the following:

1. Read these instructions.
2. Keep these instructions.
3. Heed all warnings.
4. Follow all instructions.
5. Do not use this apparatus near water.
6. Clean only with a dry cloth.
7. Do not block any of the ventilation openings. Install in accordance with manufacturer's instructions.
8. Do not install near any heat sources such as radiators, heat registers, stoves or other apparatus (including amplifiers) that produce heat.
9. Do not defeat the safety purpose of the polarized or grounding-type plug. A polarized plug has two blades with one wider than the other. A grounding type plug has two blades and a third grounding plug. The wide blade or third prong is provided for your safety. If the provided plug does not fit into your outlet, consult an electrician for replacement of the obsolete outlet.
10. Protect the power cord from being walked on or pinched, particularly at plugs, convenience receptacles, and the point they exit from the apparatus.
11. Only use attachments/accessories provided by the manufacturer.
12. Use only with a cart, stand, tripod, bracket, or table specified by the manufacturer, or sold with the apparatus. When a cart is used, use caution when moving the cart/apparatus combination to avoid injury from tip-over.
13. Unplug this apparatus during lightning storms or when unused for long periods of time.
14. Refer all servicing to qualified service personnel. Servicing is required when the apparatus has been damaged in any way, such as power-supply cord or plug is damaged, liquid has been spilled or objects have fallen into the apparatus, the apparatus has been exposed to rain or moisture, does not operate normally, or has been dropped.
15. Never break off the ground pin. Write for our free booklet "Shock Hazard and Grounding." Connect only to a power supply of the type marked on the unit adjacent to the power supply cord.
16. If this product is to be mounted in an equipment rack, rear support should be provided.
17. Note for UK only: If the colors of the wires in the mains lead of this unit do not correspond with the terminals in your plug, proceed as follows:
  - a) The wire that is colored green and yellow must be connected to the terminal that is marked by the letter E, the earth symbol, colored green or colored green and yellow.
  - b) The wire that is colored blue must be connected to the terminal that is marked with the letter N or the color black.
  - c) The wire that is colored brown must be connected to the terminal that is marked with the letter L or the color red.
18. This electrical apparatus should not be exposed to dripping or splashing and care should be taken not to place objects containing liquids, such as vases, upon the apparatus.
19. The on/off switch in this unit does not break both sides of the primary mains. Hazardous energy can be present inside the chassis when the on/off switch is in the off position. The mains plug or appliance coupler is used as the disconnect device, the disconnect device shall remain readily operable.
20. Exposure to extremely high noise levels may cause a permanent hearing loss. Individuals vary considerably in susceptibility to noise-induced hearing loss, but nearly everyone will lose some hearing if exposed to sufficiently intense noise for a sufficient time. The U.S. Government's Occupational Safety and Health Administration (OSHA) has specified the following permissible noise level exposures:



Duration Per Day In Hours	Sound Level dBA, Slow Response
8	90
6	92
4	95
3	97
2	100
1 1/2	102
1	105
1/2	110
1/4 or less	115

According to OSHA, any exposure in excess of the above permissible limits could result in some hearing loss. Ear plugs or protectors to the ear canals or over the ears must be worn when operating this amplification system in order to prevent a permanent hearing loss, if exposure is in excess of the limits as set forth above. To ensure against potentially dangerous exposure to high sound pressure levels, it is recommended that all persons exposed to equipment capable of producing high sound pressure levels such as this amplification system be protected by hearing protectors while this unit is in operation.

### SAVE THESE INSTRUCTIONS!

#### FCC Class B Notice

If your system is FCC Class B, the following applies:

Note – **This equipment has been tested and found to comply with the limits for a Class B digital device, pursuant to Part 15 of the FCC Rules.** These limits are designed to provide reasonable protection against harmful interference in a residential installation. This equipment generates, uses and can radiate radio frequency energy and, if not installed and used in accordance with the instructions, may cause harmful interference to radio communications. However, there is no guarantee that interference will not occur in a particular installation. If this equipment does cause harmful interference to radio or television reception, which can be determined by turning the equipment off and on, the user is encouraged to try to correct the interference by one or more of the following measures:

- Reorient or relocate the receiving antenna.
- Increase the separation between the equipment and receiver.
- Connect the equipment into an outlet on a circuit different from that to which the receiver is connected.
- Consult the dealer or an experienced radio/TV technician for help.

## INSTRUCCIONES IMPORTANTES PARA SU SEGURIDAD



**CUIDADO:** Cuando use productos electrónicos, debe tomar precauciones básicas, incluyendo las siguientes:

1. Lea estas instrucciones.
2. Guarde estas instrucciones.
3. Haga caso de todos los consejos.
4. Siga todas las instrucciones.
5. No usar este aparato cerca del agua.
6. Limpiar solamente con una tela seca.
7. No bloquear ninguna de las salidas de ventilación. Instalar de acuerdo a las instrucciones del fabricante.
8. No instalar cerca de ninguna fuente de calor como radiadores, estufas, hornos u otros aparatos (incluyendo amplificadores) que produzcan calor.
9. No retire la patilla protectora del enchufe polarizado o de tipo "a Tierra". Un enchufe polarizado tiene dos puntas, una de ellas más ancha que la otra. Un enchufe de tipo "a Tierra" tiene dos puntas y una tercera "a Tierra". La punta ancha (la tercera) se proporciona para su seguridad. Si el enchufe proporcionado no encaja en su enchufe de red, consulte a un electricista para que reemplace su enchufe obsoleto.
10. Proteja el cable de alimentación para que no sea pisado o pinchado, particularmente en los enchufes, huecos, y los puntos que salen del aparato.
11. Usar solamente añadidos/accesorios proporcionados por el fabricante.
12. Usar solamente un carro, pie, trípode, o soporte especificado por el fabricante, o vendido junto al aparato. Cuando se use un carro, tenga cuidado al mover el conjunto carro/aparato para evitar que se dañe en un vuelco. No suspenda esta caja de ninguna manera.
13. Desenchufe este aparato durante tormentas o cuando no sea usado durante largos periodos de tiempo.
14. Para cualquier reparación, acuda a personal de servicio cualificado. Se requieren reparaciones cuando el aparato ha sido dañado de alguna manera, como cuando el cable de alimentación o el enchufe se han dañado, algún líquido ha sido derramado o algún objeto ha caído dentro del aparato, el aparato ha sido expuesto a la lluvia o la humedad, no funciona de manera normal, o ha sufrido una caída.
15. Nunca retire la patilla de Tierra. Escríbanos para obtener nuestro folleto gratuito "Shock Hazard and Grounding" ("Peligro de Electrocuación y Toma a Tierra"). Conecte el aparato sólo a una fuente de alimentación del tipo marcado al lado del cable de alimentación.
16. Si este producto va a ser enracado con más equipo, use algún tipo de apoyo trasero.
17. Nota para el Reino Unido solamente: Si los colores de los cables en el enchufe principal de esta unidad no corresponden con los terminales en su enchufe, proceda de la siguiente manera:
  - a) El cable de color verde y azul debe ser conectado al terminal que está marcado con la letra E, el símbolo de Tierra (earth), coloreado en verde o en verde y amarillo.
  - b) El cable coloreado en azul debe ser conectado al terminal que está marcado con la letra N o el color negro.
  - c) El cable coloreado en marrón debe ser conectado al terminal que está marcado con la letra L o el color rojo.
18. Este aparato eléctrico no debe ser sometido a ningún tipo de goteo o salpicadura y se debe tener cuidado para no poner objetos que contengan líquidos, como vasos, sobre el aparato.
19. El interruptor de en/lejos en esta unidad no rompe ambos lados de la red primaria. La energía peligrosa puede ser presente dentro del chasis cuando el interruptor de en/lejos está en el de la posición. El tapón de la red o el acoplador del aparato son utilizados como el desconecta dispositivo, el desconecta dispositivo se quedará fácilmente operable.
20. La exposición a altos niveles de ruido puede causar una pérdida permanente en la audición. La susceptibilidad a la pérdida de audición provocada por el ruido varía según la persona, pero casi todo el mundo perderá algo de audición si se expone a un nivel de ruido suficientemente intenso durante un tiempo determinado. El Departamento para la Salud y para la Seguridad del Gobierno de los Estados Unidos (OSHA) ha especificado las siguientes exposiciones al ruido permisibles:

Duración por Día en Horas	Nivel de Sonido dBA, Respuesta Lenta
8	90
6	92
4	95
3	97
2	100
1 1/2	102
1	105
1/2	110
1/4 o menos	115

De acuerdo al OSHA, cualquier exposición que exceda los límites arriba indicados puede producir algún tipo de pérdida en la audición. Protectores para los canales auditivos o tapones para los oídos deben ser usados cuando se opere con este sistema de sonido para prevenir una pérdida permanente en la audición, si la exposición excede los límites indicados más arriba. Para protegerse de una exposición a altos niveles de sonido potencialmente peligrosa, se recomienda que todas las personas expuestas a equipamiento capaz de producir altos niveles de presión sonora, tales como este sistema de amplificación, se encuentren protegidas por protectores auditivos mientras esta unidad esté operando.

**GUARDE ESTAS INSTRUCCIONES!**

## INSTRUCTIONS IMPORTANTES DE SECURITE

FRANÇAIS

ATTENTION: L'utilisation de tout appareil électrique doit être soumise aux précautions d'usage incluant:



1. Lire ces instructions.
2. Gardez ce manuel pour de futures références.
3. Prêtez attention aux messages de précautions de ce manuel.
4. Suivez ces instructions.
5. N'utilisez pas cette unité proche de plans d'eau.
6. N'utilisez qu'un tissu sec pour le nettoyage de votre unité.
7. N'obstruez pas les systèmes de refroidissement de votre unité et installez votre unité en fonction des instructions de ce manuel.
8. Ne positionnez pas votre unité à proximité de toute source de chaleur.
9. Connectez toujours votre unité sur une alimentation munie de prise de terre utilisant le cordon d'alimentation fourni.
10. Protégez les connecteurs de votre unité et positionnez les cablages pour éviter toutes déconnexions accidentelles.
11. N'utilisez que des fixations approuvées par le fabricant.
12. Lors de l'utilisation sur pied ou pole de support, assurez dans le cas de déplacement de l'ensemble enceinte/support de prévenir tout basculement intempestif de celui-ci.
13. Il est conseillé de déconnecter du secteur votre unité en cas d'orage ou de durée prolongée sans utilisation.
14. Seul un technicien agréé par le fabricant est à même de réparer/contrôler votre unité. Celle-ci doit être contrôlée si elle a subi des dommages de manipulation, d'utilisation ou de stockage (humidité,...).
15. Ne déconnectez jamais la prise de terre de votre unité.
16. Si votre unité est destinée à être montée en rack, des supports arriere doivent être utilisés.
17. Note pour les Royaumes-Unis: Si les couleurs de connecteurs du câble d'alimentation ne correspond pas au guide de la prise secteur, procédez comme suit:
  - a) Le connecteur vert et jaune doit être connecter au terminal noté E, indiquant la prise de terre ou correspondant aux couleurs verte ou verte et jaune du guide.
  - b) Le connecteur Bleu doit être connecter au terminal noté N, correspondant à la couleur noire du guide.
  - c) Le connecteur marron doit être connecter au terminal noté L, correspondant à la couleur rouge du guide.
18. Cet équipement électrique ne doit en aucun cas être en contact avec un quelconque liquide et aucun objet contenant un liquide, vase ou autre ne devrait être posé sur celui-ci.
19. L'interrupter (on-off) dans cette unité ne casse pas les deux côtés du primaire principal. L'énergie hasardeuse peut être présente dans châssis quand l'interrupter (on-off) est dans le de la position. Le bouchon principal ou atelage d'appareil est utilisé comme le débrancher l'appareil restera facilement opérable.
20. Une exposition à de hauts niveaux sonores peut conduire à des dommages de l'écoute irréversibles. La susceptibilité au bruit varie considérablement d'un individu à l'autre, mais une large majorité de la population expérencera une perte de l'écoute après une exposition à une forte puissance sonore pour une durée prolongée. L'organisme de la santé américaine (OSHA) a produit le guide ci-dessous en rapport à la perte occasionnée:

Durée par Jour (heures)	Niveau sonore moyen (dBA)
8	90
6	92
4	95
3	97
2	100
1 1/2	102
1	105
1/2	110
1/4 ou inférieur	115

D'après les études menées par le OSHA, toute exposition au delà des limites décrites ce-dessus entrainera des pertes de l'écoute chez la plupart des sujets. Le port de système de protection (casque, oreillette de filtrage,...) doit être observé lors de l'opération cette unité ou des dommages irréversibles peuvent être occasionnés. Le port de ces systèmes doit être observé par toutes personnes susceptibles d'être exposées à des conditions au delà des limites décrites ci-dessus.

**GARDEZ CES INSTRUCTIONS!**

## WICHTIGE SICHERHEITSHINWEISE

ACHTUNG: Beim Einsatz von Elektrogeräten müssen u.a. grundlegende Vorsichtsmaßnahmen befolgt werden:



1. Lesen Sie sich diese Anweisungen durch.
2. Bewahren Sie diese Anweisungen auf.
3. Beachten Sie alle Warnungen.
4. Befolgen Sie alle Anweisungen.
5. Setzen Sie dieses Gerät nicht in der Nähe von Wasser ein.
6. Reinigen Sie es nur mit einem trockenen Tuch.
7. Blockieren Sie keine der Lüftungsöffnungen. Führen Sie die Installation gemäß den Anweisungen des Herstellers durch.
8. Installieren Sie das Gerät nicht neben Wärmequellen wie Heizungen, Heizgeräten, Öfen oder anderen Geräten (auch Verstärkern), die Wärme erzeugen.
9. Beeinträchtigen Sie nicht die Sicherheitswirkung des gepolten Steckers bzw. des Erdungssteckers. Ein gepolter Stecker weist zwei Stifte auf, von denen einer breiter ist als der andere. Ein Erdungsstecker weist zwei Stifte und einen dritten Erdungsstift auf. Der breite Stift bzw. der dritte Stift dient Ihrer Sicherheit. Sollte der beiliegende Stecker nicht in Ihre Steckdose passen, wenden Sie sich bitte an einen Elektriker, um die ungeeignete Steckdose austauschen zu lassen.
10. Schützen Sie das Netzkabel, sodass niemand darauf tritt oder es geknickt wird, insbesondere an Steckern oder Buchsen und ihren Austrittsstellen aus dem Gerät.
11. Verwenden Sie nur die vom Hersteller erhältlichen Zubehörgeräte oder Zubehörteile.
12. Verwenden Sie nur einen Wagen, Stativ, Dreifuß, Träger oder Tisch, der den Angaben des Herstellers entspricht oder zusammen mit dem Gerät verkauft wurde. Wird ein Wagen verwendet, bewegen Sie den Wagen mit dem darauf befindlichen Gerät besonders vorsichtig, damit er nicht umkippt und möglicherweise jemand verletzt wird.
13. Trennen Sie das Gerät während eines Gewitters oder während längerer Zeiträume, in denen es nicht benutzt wird, von der Stromversorgung.
14. Lassen Sie sämtliche Wartungsarbeiten von qualifizierten Kundendiensttechnikern durchführen. Eine Wartung ist erforderlich, wenn das Gerät in irgendeiner Art beschädigt wurde, etwa wenn das Netzkabel oder der Netzstecker beschädigt wurden, Flüssigkeit oder Gegenstände in das Gerät gelangt sind, das Gerät Regen oder Feuchtigkeit ausgesetzt wurde, nicht normal arbeitet oder heruntergefallen ist.
15. Der Erdungsstift darf nie entfernt werden. Auf Wunsch senden wir Ihnen gerne unsere kostenlose Broschüre „Shock Hazard and Grounding“ (Gefahr durch elektrischen Schlag und Erdung) zu. Schließen Sie nur an die Stromversorgung der Art an, die am Gerät neben dem Netzkabel angegeben ist.
16. Wenn dieses Produkt in ein Geräte-Rack eingebaut werden soll, muss eine Versorgung über die Rückseite eingerichtet werden.
17. Hinweis – Nur für Großbritannien: Sollte die Farbe der Drähte in der Netzleitung dieses Geräts nicht mit den Klemmen in Ihrem Stecker übereinstimmen, gehen Sie folgendermaßen vor:
  - a) Der grün-gelbe Draht muss an die mit E (Symbol für Erde) markierte bzw. grüne oder grün-gelbe Klemme angeschlossen werden.
  - b) Der blaue Draht muss an die mit N markierte bzw. schwarze Klemme angeschlossen werden.
  - c) Der braune Draht muss an die mit L markierte bzw. rote Klemme angeschlossen werden.
18. Dieses Gerät darf nicht ungeschützt Wassertropfen und Wasserspritzern ausgesetzt werden und es muss darauf geachtet werden, dass keine mit Flüssigkeiten gefüllte Gegenstände, wie z. B. Blumenvasen, auf dem Gerät abgestellt werden.
19. Der Netzschalter in dieser Einheit bricht beide Seiten von den primären Hauptleitungen nicht. Gefährliche Energie kann anwesend innerhalb des Chassis sein, wenn her Netzschalter im ab Poistion ist. Die Hauptleitungen stöpseln zu oder Gerätkupplung ist benutzt, während das Vorrichtung abschaltet, das schaltet Vorrichtung wird bleiben sogleich hantierbar ab.
20. Belastung durch extrem hohe Lärmpegel kann zu dauerhaftem Gehörverlust führen. Die Anfälligkeit für durch Lärm bedingten Gehörverlust ist von Mensch zu Mensch verschieden, das Gehör wird jedoch bei jedem in gewissem Maße geschädigt, der über einen bestimmten Zeitraum ausreichend starkem Lärm ausgesetzt ist. Die US-Arbeitsschutzbehörde (Occupational and Health Administration, OSHA) hat die folgenden zulässigen Pegel für Lärmbelastung festgelegt:

Dauer pro Tag in Stunden	Geräuschpegel dBA, langsame Reaktion
8	90
6	92
4	95
3	97
2	100
1 1/2	102
1	105
1/2	110
1/4 oder weniger	115

Laut OSHA kann jede Belastung über den obenstehenden zulässigen Grenzwerten zu einem gewissen Gehörverlust führen. Sollte die Belastung die obenstehenden Grenzwerte übersteigen, müssen beim Betrieb dieses Verstärkungssystems Ohrstöpsel oder Schutzhörgeräte im Gehörgang oder über den Ohren getragen werden, um einen dauerhaften Gehörverlust zu verhindern. Um sich vor einer möglicherweise gefährlichen Belastung durch hohe Schalldruckpegel zu schützen, wird allen Personen empfohlen, die mit Geräten arbeiten, die wie dieses Verstärkungssystem hohe Schalldruckpegel erzeugen können, beim Betrieb dieses Geräts einen Gehörschutz zu tragen.

**BEWAHREN SIE DIESE SICHERHEITSHINWEISE AUF!**

## **PCX U1002 WIRELESS RECEIVER**

1. INTRODUCTION-----	8
2. PART NAMES AND FUNCTIONS-----	9-10
3. INSTALLATION OF THE RECEIVER-----	11-12
4. 19" RACK INSTALLATION OF RECEIVER(S)-----	13-14
5. RECEIVER OPERATING PROCEDURES-----	15
6. FUNCTIONS OF RECEIVER LCD DISPLAY PANEL----	15-23
7. COMPUTER NETWORK INTERFACE OPERATION----	24-25
8. CAUTIONS-----	25

## **HANDHELD WIRELESS MICROPHONE**

1. PART NAMES AND FUNCTIONS-----	24
2. BATTERY INSTALLATION-----	24
3. OPERATING INSTRUCTIONS-----	25
4. FUNCTIONS OF LCD DISPLAY-----	25-26

## **BELT PACK TRANSMITTER**

1. PART NAMES AND FUNCTIONS-----	27-28
2. BATTERY INSTALLATION-----	29
3. OPERATING INSTRUCTIONS-----	30
4. AF4 PINOUT AND CONNECTION METHODS-----	31
5. FUNCTIONS OF LCD DISPLAY-----	32-33

## 1. INTRODUCTION

Thank you for choosing the most advanced wireless microphone system from Peavey.

In today's audio world, the demand for operating many wireless microphone systems simultaneously is greatly increasing. Furthermore, audio engineers would like to have a unit that has easy frequency agility, more non-interfering channels and interference-free operation.

The PCX U1002 is a compact rack unit. This true diversity metal receiver features the world's first color LCD panel displaying multiple statuses. It employs an "AutoScan" button that automatically searches for non-interfering channels with the simple touch of the button. A simple touch of the "CCS" button will provide rapid and precise channel setting of the transmitter avoiding possible errors or mechanical failures. This is the perfect single system for use in all applications. It is based on years of experience in the professional audio market to resolve issues like quick-change of frequency, selection of non-interfering frequencies and avoiding outside interference to maximize your wireless system. Space saving, stable performance, ease of operation, coupled with unbeatable prices, make this an extremely attractive system.

Please read this manual thoroughly for correct operation procedures and optimal performance from your system.

### **Included Accessories:**

- (1) Antenna (2)
- (2) Instructional Manual (1)
- (3) Switching Power Supply with IEC Line Cord (1)
- (4) 1/4" Mono Cable (1)
- (5) RJ11 Cable (PC Operation) (1)



## 2. PART NAMES AND FUNCTIONS

Front Panel:

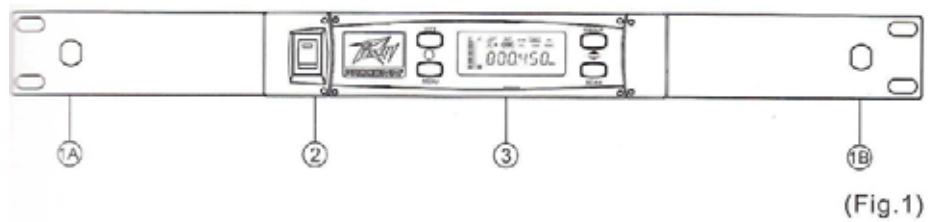

- (1) Front Antenna Input Connectors (A and B): located on optional rack-mount ears: Allows an optional rear-to-front Antenna kit for front antenna placement on OPTIONAL rack-mount brackets.
- (2) Power Switch and Indicator: When switch is turned on, the red indicator illuminates, indicating normal power status.
- (3) Receiver Panel: Color LCD Panel indicating adjustment controls and operational status.

**Rear Panel:**

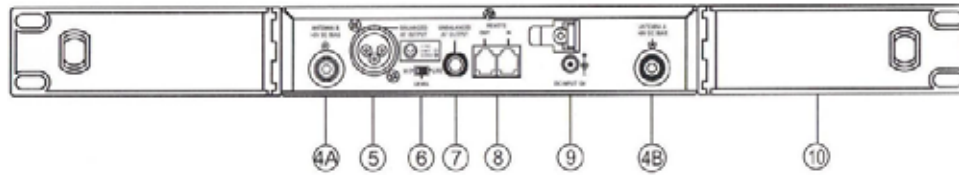

(Fig .2)

- (4) Rear Antenna Input Connectors (A/B): Installed with antenna directly. This connector also provides power for optional antenna booster.
- (5) Balanced Audio output Jack: XLR type connector provides a balanced output signal from the receiver to the mixer.
- (6) Line-Level Switch: Used for the selection of either Mic-level or Line-level output.
- (7) Unbalanced Audio output Jack: 1/4" Phone jack provides an unbalanced signal from the receiver to the mixer or guitar/bass amplifier.
- (8) Computer Network Interface connector: Network socket to connect to a computerized system-monitoring program.
- (9) DC Input socket: For 12 volt DC supply. Please note that the polarity of the center pin in the socket is positive (+),
- (10) Rack mount Brackets (OPTIONAL): Allows the installation of the receiver into an EIA 19" standard rack case.

### 3. INSTALLATION OF THE RECEIVER

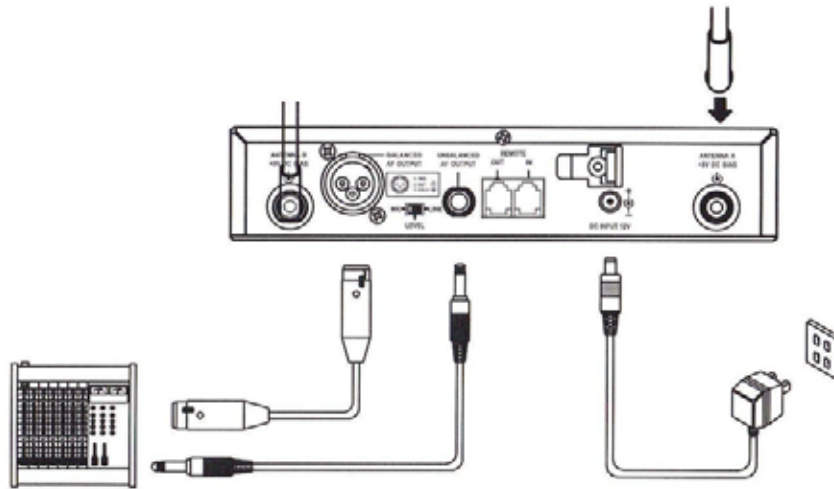

(Fig.3)

- (1) Install the two antennas to the antenna sockets (4) on the rear panel, illustrated in Fig. 3 or on front rack-mount ears (1). **Caution:** These sockets have 8 Volts DC supplied to them, which enables you to directly connect the Peavey antenna booster for antenna runs longer than 30' (9.144m). At that point it is recommended that you install an optional antenna booster to make up for signal loss through the cable and ensure the sensitivity of the reception.
- (2) Connecting the power supply: Connect the AC/DC adapter cable to the 12VDC Input Jack (10) illustrated in Fig. 3. Next, plug the adapter unit into an appropriate AC outlet with caution to the correct voltage for both AC outlet and adapter as marked.
- (3) Audio Output Connections:

- (a) Unbalanced Output: When using an instrument/patch cable, connect one end of the cable to the unbalanced output (8) of the receiver and the other end to the "LINE IN" jack of a mixer or guitar/bass amplifier input, as illustrated in Fig. 3.
- (b) Balanced Output: When using an XLR (microphone) cable, connect the female end of the cable to the balanced XLR output connector (9) on the receiver and the male end of the cable to the microphone input of the mixer, as illustrated in Fig.3. The polarity of the three-pin XLR is illustrated in Fig. 4.



(Fig.4)

- (4) Line-Level Switch (7) Setting Position: When connecting the unbalanced output of the receiver to a line-level input of a mixer or guitar/bass amplifier, switch the Level Switch (7) to the "LINE" position. Low sensitivity may occur if it's switched to the incorrect position. When the unbalanced output of the receiver is connected to a microphone input on the mixer, switch the Level switch (7) to the "MIC" position. Overloading or distortion may occur if the switch is in the incorrect position. Insufficient levels may be generated by using the "MIC" position of the Level switch with instruments.

## 4. 19" RACK INSTALLATION

### (1) Single Receiver (Half-rack)

- (a) Fasten OPTIONAL rack-mount kit to receiver using supplied screws on each side of the receiver as illustrated in Fig. 5.

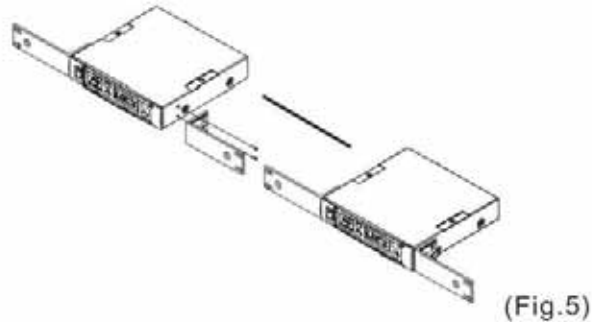

### (2) Dual Receivers (Full-Rack)

- (a) Remove the screws located on the top and bottom of both units and locate the units next to each other and align.
- (b) Insert the steel plates (one on top, one on bottom) between the receivers and align mounting holes. Reattach the screws tightly as illustrated in Fig. 6.
- (c) Attach rack ears to receivers as illustrated in Fig. 6.

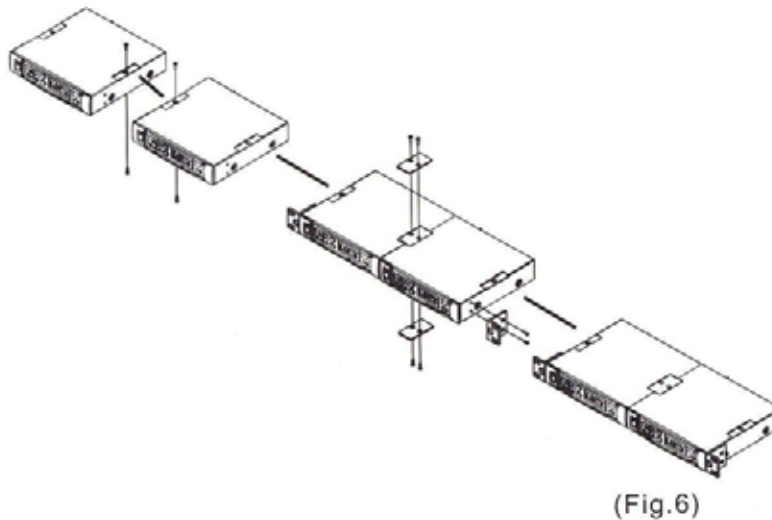

(3) Mount the receiver(s) into a standard 19" rack as illustrated in Fig. 7.

**NOTE:** To ensure best possible reception, the receiver must be installed at least 3' (.914m) above the ground. In addition, the distance between the transmitter and receiver must be more than 3' (.914m) as illustrated in Fig.8.

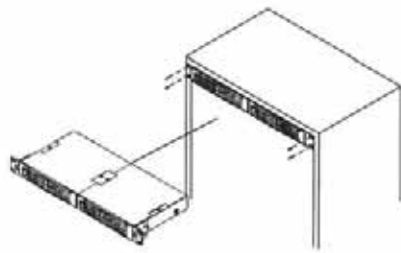

(Fig.7)

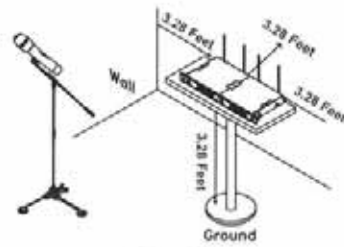

(Fig.8)

## 5. RECEIVER OPERATING PROCEDURES

- (1) Be sure that the level controls of the mixer or guitar/bass amplifier are turned down to a minimum setting before switching on the receiver. After the receiver power switch has been turned on, the red power LED indicator will illuminate.
- (2) Under normal circumstances, the RF indicator lights up when a microphone or body pack is turned on near the receiver to indicate that the receiver is ready for operation. Once the sound is induced into the microphone or belt pack, the AF indicators will illuminate according to the strength of the signal level.
- (3) Level controls should be set at the mixer or amplifier.

## 6. FUNCTION OF RECEIVER LGD DISPLAY PANEL

- (1) Designations of Buttons and Functions

**MENU Button: Enables user to scroll through (select) each the six functions**

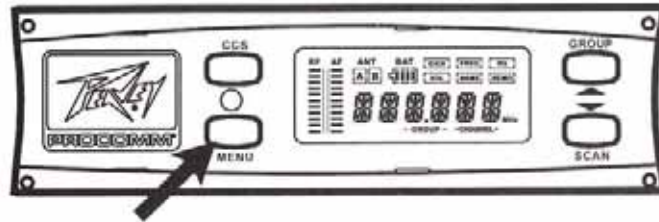

The menu button allows the user to scroll through and select from among six options (as shown on pg.13). When selected, the function will be surrounded by a square frame in the upper right of the LCD display. Information associated with that function is viewable in the lower half of the LCD display.

G/CH → FREQ → SQ → VOL → NAME → REMO

- (a) **G/CH:** Indicates or selects the receiver GROUP and CHANNEL. There are nine separate Groups. Each group contains between three and 16 separate channels, giving 100 different channels for use.

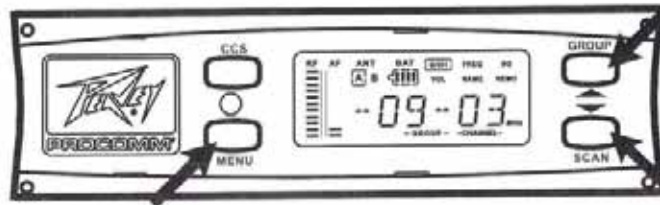

Selecting/Changing GROUP:



Press the "MENU" button until the "G/CH" function is selected. This will be indicated by a block that will appear around the selected function located in the upper right corner of the display.

Press the "GROUP" ▲ button once. The Group Number on the display will start flashing. Press the button again to scroll to the desired group number. Holding the button will also scroll through the group numbers. Pressing the "MENU" button again will save the group number.



## Selecting/Changing CHANNEL:

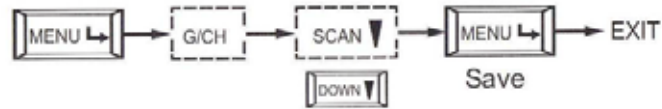

**NOTE: In order for the receiver to recognize that a frequency is occupied, make sure all transmitters that are to be used are powered up.**

Press the "MENU" button until the "G/CH" function is selected. This will be indicated by a block that will appear around the selected function located in the upper right corner of the display.

Press the "SCAN" ▼ button once and the Channel Number on the display will start flashing. Pressing the "SCAN" button again will start the AutoScan process for that group. The unit will search for a channel that is not experiencing interference and stop on that channel. If the channel number keeps scrolling by, this means that all channels in that particular group are experiencing interference. You should select another group and repeat the process. Once you have found a channel, then press the "MENU" button to save and escape the function.

(b) **FREQ:** Indicates the frequency currently in use. There are 100 channels, each with its own designated frequency.

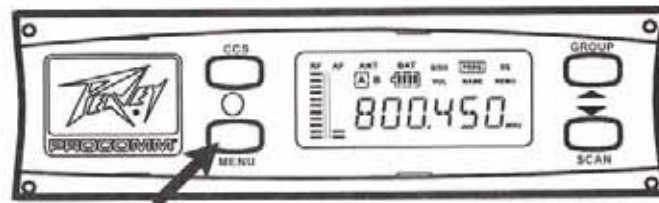

## Viewing Channel FREQUENCY:

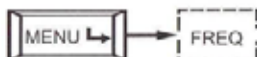

Press the "MENU" button until the "FREQ" function is selected. This will be indicated by a block that will appear around the selected function located in the upper right corner of the display. The frequency displayed will be for that particular channel for that particular group. Press the "MENU" button to escape the function.

(c) **SQ:** Indicates or selects the SQUELCH level: Squelch is a control that will not allow the audio signal to turn on before the RF signal reaches a certain strength. Too low of a squelch level will allow a noisy audio signal to pass. Too high of a level will cause the audio signal to become choppy and intermittent. The Squelch level is adjustable from 01 - 99. The higher the value, the lower the sensitivity.

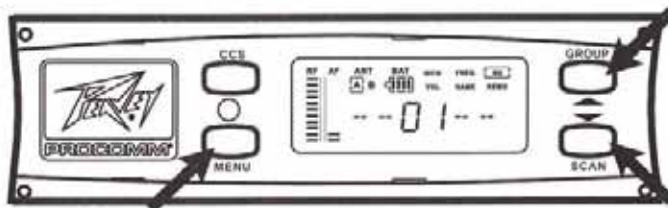

## Selecting/Adjusting SQ:

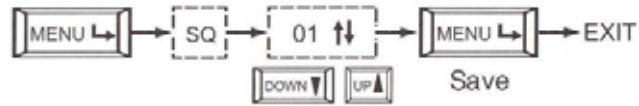

Press the "MENU" button until the "SQ" function is selected. This will be indicated by a block that will appear around the selected function located in the upper right corner of the display.

Press the "GROUP" ▲ button or the "SCAN" ▼ button to either increase or decrease the level. Press the Menu button to save and escape the function.

(d) **VOL:** Indicates whether the audio is "ON" or "MUTE"

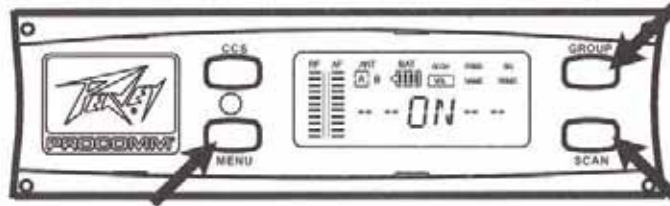

## Selecting/Changing MUTE:

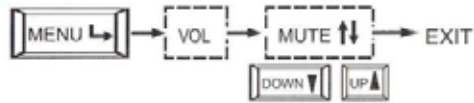

Press the "MENU" button until the "VOL" function is selected. This will be indicated by a block that will appear around the selected function located in the upper right corner of the display.

Press the "GROUP" ▲ button or the "SCAN" ▼ button to place the receiver in a "Mute" or "ON." Press the Menu button to save and escape.

**CAUTION:** The AF meter and the Antenna "A," "B" will not be functional with the receiver muted. To determine if the receiver is in the "MUTE" position, press the "MENU" button until the "VOL" function is selected and it will be indicated by LCD display "MUTE" if muted and "ON" if unmuted.

- (e) **NAME:** Indicates or sets up the name of the receiver. This allows you to give a six character identification to the receiver (i.e. user's name, instrument name etc.). This is extremely helpful when in a rack or with other devices.

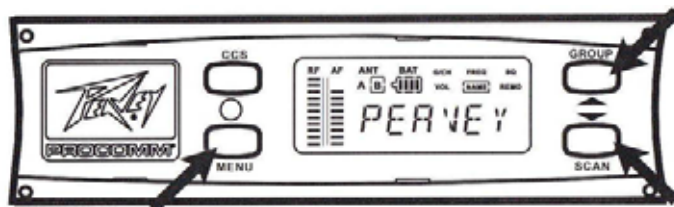

### Selecting/Setting Name:

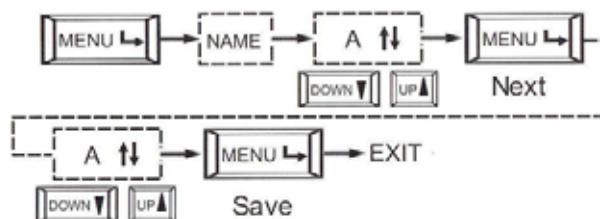

Press the "MENU" button until the "NAME" function is selected. This will be indicated by a block that will appear around the selected function located in the upper right corner of the display.

Press and hold the "GROUP" ▲ button or the "SCAN" ▼ button. The character in the far left position will start to blink (if the character is a space it will not blink). This will allow you to scroll through letters, numbers and characters +, -, / and space. When the character desired is reached, again press the "MENU" button to proceed to the second position character. Then repeat process until all six are completed. Press the Menu button to save and escape the function.

**CCS: Enables the user to change channels on the transmitter by simply pressing a button**

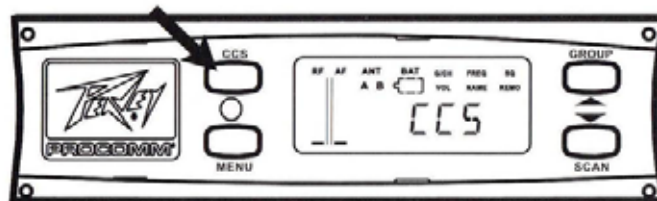

### Selecting/Operating CCS :

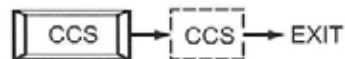

Once the Group and Channel have been established on the receiver, the information must be transferred to the transmitter.

With the transmitter switched to the ON position, arrange it so that the rear of the handheld transmitter or the face of the belt pack transmitter are facing the receiver as illustrated in Fig. 9. Move the transmitter within the distance of 1'. Press and release the "CCS" button. This will transmit the information from the receiver to the transmitter. While you perform this operation, "CCS" will be indicated in the Display. Once the information is transferred, the "RF" and "AF" meters should respond accordingly to the signal strengths and the previous function information should return to the display.

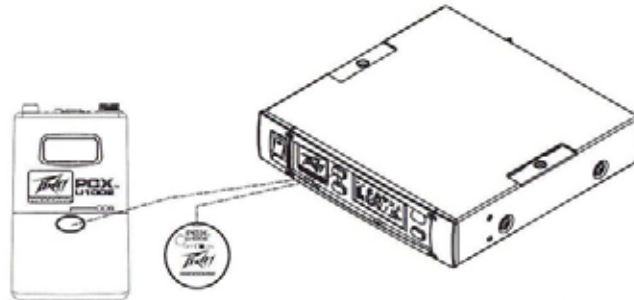

(Fig.9)

### Selecting/Changing LOCK/UNLOCK:

Press and hold the "MENU" button until the word "LOCK" appears momentarily on the panel. At that point only the "CCS" button is active. This prevents inadvertent or unintentional changes to the settings.

Press and hold the "MENU" button until the word "UNLOCK" appears on the panel. At that point all functions are addressable and changes can be made.

### Status Indicators

- (a) **RF Meter:** The meter to the left of the display indicates the strength of the RF signal.
- (b) **AF Meter:** The meter to the right (next to RF meter) indicates the strength of the audio signal.
- (c) **ANT AJB:** Indicates which antenna is operational at that moment. This will switch between the two, selecting the antenna with the greater strength for a more reliable reception.
- (d) **BAT:** Battery strength indicator allows you to monitor the strength of the Battery.

## 7. COMPUTER NETWORK INTERFACE OPERATION

- (1) Connect the network interface remote connector (8) on the back of the receiver to the interface converter (this requires at least two linking cables for each pairing). Then use RJ 11 telephone cable to connect the converter to the RS-232 or USB COM PORT on the computer as illustrated in Fig. 10

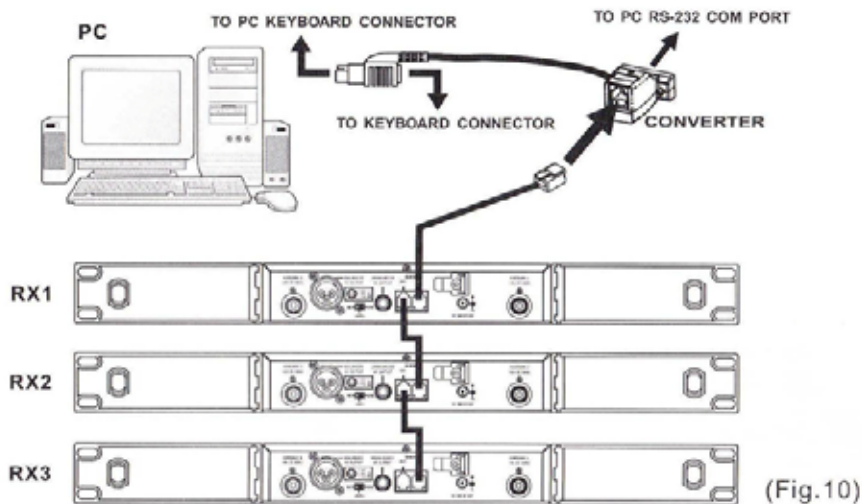

- (2) When linking more than one unit, attach one end of the additional cable to the remote "OUT" jack (8) on the back of the first receiver and connect the other end of the cable to the remote "IN" jack on the back of the second receiver as illustrated in Fig. 10. Continue these parallel connections until all receivers are linked to the first receiver.
- (3) This interface system adapts parallel connections. Therefore, it only takes two linking cables to address the first receiver and one additional cable for each receiver after that.
- (4) The longer the distance to the converter, the worse the system stability may be. The network system can work up to with up to 984' (300m) of linking wire. However, it is our recommendation to keep this cable under 328' (100m) to ensure high speed transmission.



## **System Requirements:**

- Windows 98R, Windows 2000R
- 32MB RAM Minimum (64MB is recommended)
- CD-ROM 2X or higher
- At Least one nine-pin D-Sub RS-232 port (for RJ-11/RS-232 Converter)

## **8. CAUTIONS**

- (1) When using the DC power supply, please be aware of the operating voltage. Make sure that a minimum of 12 Volts can be obtained in order for the receiver to function properly. However, the supply voltage should never exceed 15 Volts DC, or the receiver could suffer severe internal damage. It is recommended that the DC power source be rated at least 1 Amp.
- (2) To ensure maximum sensitivity, use only the proper antennas designed for Peavey receivers.
- (3) Antenna sockets have 8VDC supplied to them for the operation of boosters if necessary. DO NOT SHORT the antenna connector. Make ALL connections to the receiver before powering up.

## 1. PART NAMES AND FUNCTIONS

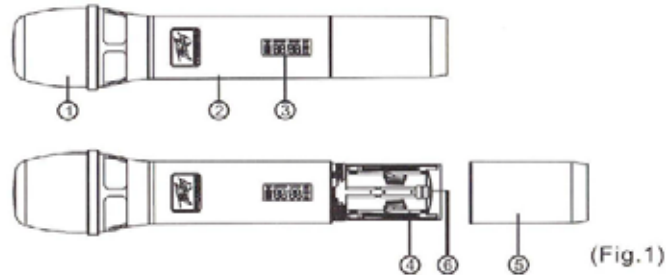

- (1) Grille: Protects microphone capsule and reduces "POP" noise.
- (2) Handle Housing: Houses electronics and battery compartment
- (3) LCD Display: Indicates function information such as Error, Group ID, Channel ID, Battery Status and Power Off
- (4) Battery Compartment: Designed to accommodate two 1.5 Volt (AA) batteries
- (5) Battery Cap: Covers batteries and battery compartment
- (6) CCS Signal Receptor: Houses CCS receiving unit that reads information transmitted to the unit by the receiver unit to set up desired frequency for use.

## 2. BATTERY INSTALLATION

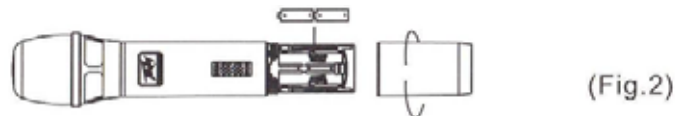

- (1) Remove Battery Cap by unscrewing in a counter/clockwise direction
- (2) Insert two 1.5 Volt (AA) batteries correctly into the battery compartment with the positive poles facing toward the microphone capsule. Then re-attach battery cap as illustrated in Fig. 2.

NOTE: When microphone is not in use make sure it is switched off. If the microphone will not be used for some time, please remove the batteries from the battery compartment to avoid battery leakage which could result in damage to the microphone. If rechargeable batteries are used, remove and recharge when necessary.

### 3. OPERATING INSTRUCTIONS

- (1) Power on: when powering up the microphone, switch the power switch (2) to the ON position- The Battery Status indicator will flash briefly, indicating normal operational status. (b)When the indicator remains illuminated or does not illuminate at all, the battery level is low or exhausted and must be replaced for continued operation.
- (2) Determine Channel/Group: After you power up the transmitter, check to see that it is assigned to the same channel/group as the receiver. If you find they do not match then follow the G/CH setup procedures (pages 8 -9).

### 4. FUNCTIONS OF LCD DISPLAY



- (1) "ERR" Message: when "ERR" appears in the display it indicates that an operational error has occurred. Please refer to the following codes to diagnose which error you are experiencing.

ERR no01 - EEPROM is not being programmed or internal data error

ERR no02 - For testing only

ERR no03 - The frequency you are about to program into the system exceeds the microphone's frequency upper limit (At this time the microphone is still operable and the frequency remains unchanged. To clear the "ERR" message in the LCD display, simply turn off the power and switch back on.).

ERR no04 - The frequency you are about to program into the system is below the microphone's frequency lower limit (At this time the microphone is still operable and the frequency remains unchanged. To clear the "ERR" message in LCD display, simply turn off the power and switch back on.).

- (2) "GROUP" and "CHANNEL": When both items are shown, they indicate the user is currently using a pre-programmed frequency in the receiver.
- (3) "CHANNEL" Only: If only the channel number is shown in the display, it indicates the user is using a personalized frequency.
- (4) Battery Status: Indicates the power remaining in the transmitter battery. When the battery has less than 10% power remaining, it must be replaced or recharged. If under-voltage continues, the LCD will show "Poff" and the system will shut down to prevent being overly depleted.

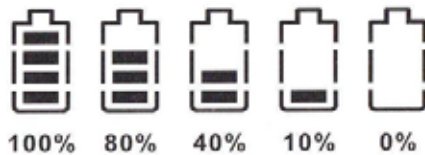

- (5) "Poff": When the power switch is turned off, the LCD will show "Poff" (for Power Off) first and then the system will shut down and no further messages will be displayed.

## 1. PART NAMES AND FUNCTIONS

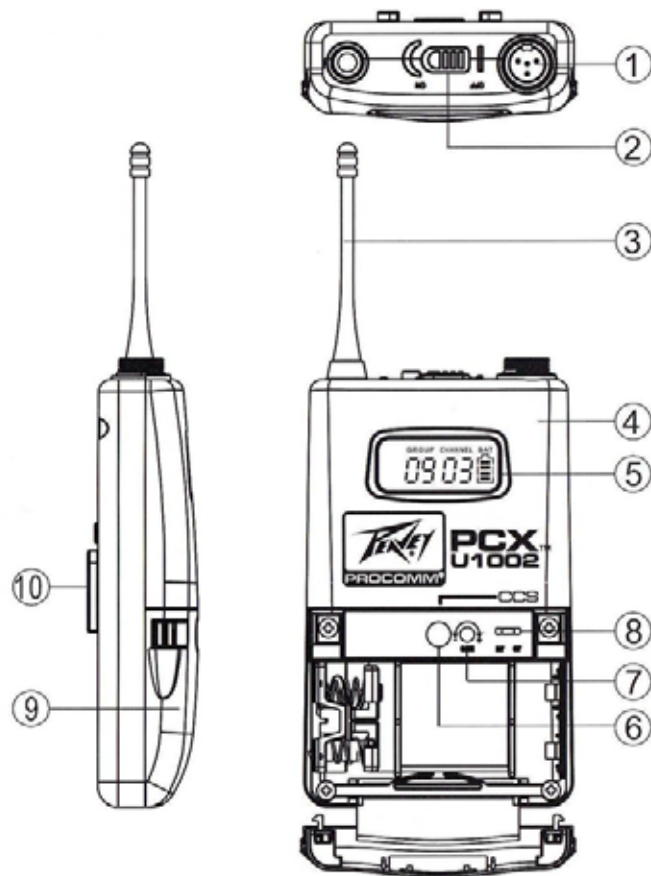

(Fig.1)

- (1) AF Input Jack: Connects to lavalier, headset microphones or to guitar cable. (see P23 for five different ways of connecting the TA4F AF input connector).
- (2) Power Switch: Powers up unit. Switch to OFF position when not in use to extend battery life.

- (3) Battery Status Indicator: Indicates the power on and battery condition. (a) When the power switch is turned on, the indicator will flash briefly, indicating normal operational status. (b) When the indicator remains illuminated the battery level is low and must be replaced for continued operation.
- (4) Transmitting Antenna: 1/4" Wave-transmitting antenna.
- (5) Transmitter Housing: Houses electronics and battery compartment.
- (6) Display: Indicates function information such as Error, Group ID, Channel ID, Battery Status and Power Off.
- (7) CCS Signal Receptor: Houses CCS receiving unit that reads information transmitted to the unit by the receiver unit to set up desired frequency for use.
- (8) Gain Control: Allows for the adjustment of various gain settings needed for different applications.
- (9) GT/MT Level Switch: Switch to the "GT" position for usage with the guitar, bass guitar or "Line In." The Gain Control does not operate with the switch in the "GT" position. Select the "MI" position when using the lavalier or headset. Then use the Gain Control function to adjust the amount of gain necessary for the input sensitivity.
- (10) Battery Compartment and Adjustment Control Panel Cover: This cover conceals both the battery compartment, which is designed to accommodate two 1.5 Volt (AA) batteries, and the adjustment control panel where the CCS Signal Receptor (7), GT/MT (8) and Gain level control switch (9) are located. To gain access to these, press the snaplocks on both sides of the cover (see Fig. 1) and lift the cover up in a hinging motion.

- (11) Detachable Belt Clip: Allows for 360 degrees of rotation to suit transmitting angles. To detach, simply use a screwdriver on a 45-degree angle to unfasten (see Fig. 2).

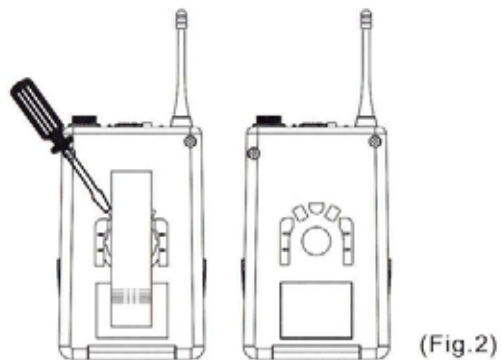

## 2. BATTERY INSTALLATION

- (1) Push in on both battery cover snap locks (10) to open battery compartment as illustrated in Fig.3

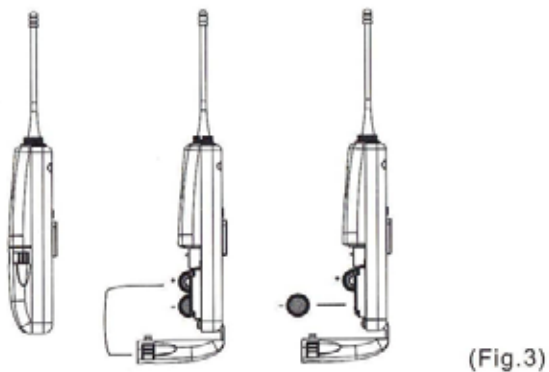

- (2) Insert two 1.5 Volt (AA) batteries into the battery compartment, being careful of the proper polarity as illustrated in Fig.4

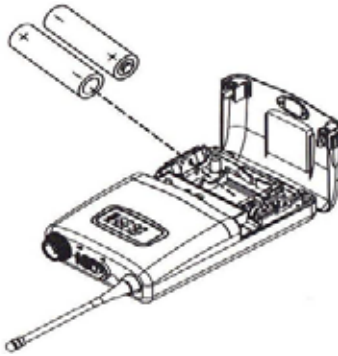

(Fig.4)

NOTE: When transmitter is not in use, make sure it is switched off.

If the transmitter will not be used for some time, please remove the batteries from the battery compartment to avoid battery leakage which could result in damage to the microphone. If rechargeable batteries are used, remove and recharge when necessary.

### 3. OPERATING INSTRUCTIONS

- (1) Select GT/MT Switch (9) position: Determine the use of the Belt Pack Transmitter. If a lavalier or headset microphone will be used, the switch should be set in the MT position. If using a guitar/bass or with a line-level device (pre-amp out), the switch should be set in the GT position.
- (2) Power On: When powering up the transmitter, switch the power switch (2) to the ON position. The Battery Status indicator will flash briefly, indicating normal operational status. (b) When the indicator remains illuminated or does not illuminate at all, the battery level is low or exhausted and must be replaced for continued operation.
- (3) Determine Channel/Group: After you power up the transmitter, check to see that it is assigned to the same channel/group as the receiver. If you find they do not match then follow the G/CH setup procedures (pages 8 – 9).



- (4) Connecting mics or cable: Before making these connections, power down the transmitter to prevent damage. Make these connections by plugging the connector into the AF input jack (1) and tightening the locking connector down by rotating it in a clockwise direction as illustrated in Fig.5. Then power unit up again.

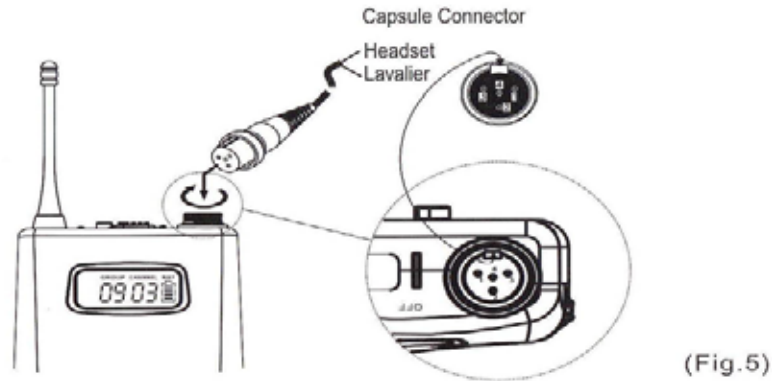

- (5) Adjust Gain Control: Depending on the application of the transmitter, it may be necessary to make adjustments to the Gain Control. Viewing the AF signal level present on the front panel of the receiver may help to determine if adjustments need to be made.

#### 4. AF 4-PIN INPUT CONNECTION METHODS

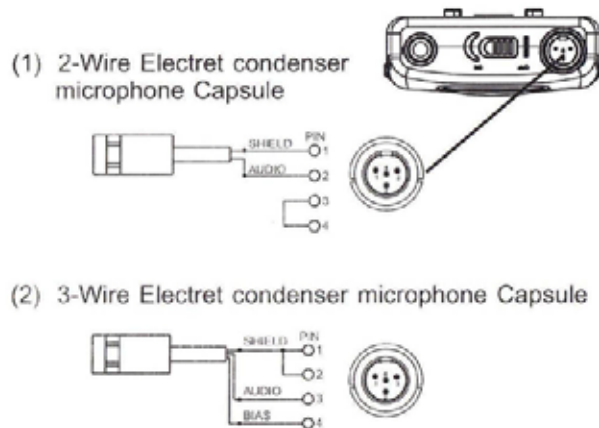

(3) Dynamic Microphone

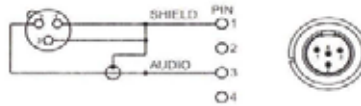

(4) Electric Guitar

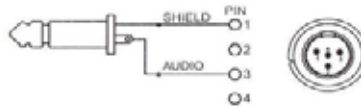

(5) Line-in (Impedance 8K $\Omega$ )

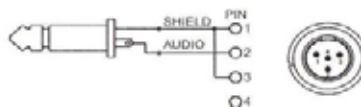

## 5. FUNCTIONS OF LCD DISPLAY



(1) "ERR" Message: When "ERR" appears in the display it indicates that an operational error has occurred. Please refer to the following codes to diagnose which error you are experiencing

ERR no01 - EEPROM is not being programmed or internal data error.

ERR no02 - For testing only.

ERR no03 - The frequency you are about to program into the system exceeds the microphone's frequency upper limit (At this time the microphone is still operable and the frequency remains unchanged. To clear the "ERR" message in the LCD display, simply turn off the power and switch back on.)

ERR no04 - The frequency you are about to program into the system is below the microphone's frequency lower limit (At this time the microphone is still operable and the frequency remains unchanged. To clear the "ERR" message in LCD display, simply turn off the power and switch back on.).

- (2) "GROUP" and "CHANNEL": when both items are shown they indicate the user is currently using a pre-programmed frequency in the receiver.
- (3) "CHANNEL" Only: If only the channel number is shown in the display, it indicates the user is using a personalized frequency.
- (4) Battery Status: Indicates the power remaining in the transmitter battery. When the battery has less than 10% power remaining it must be replaced or recharged. If under-voltage continues, the LCD will show "Poff" and the system will shut down to prevent being overly depleted.

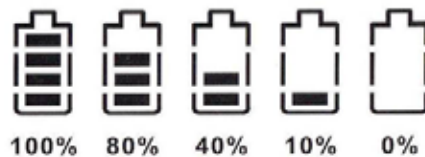

- (5) "Poff": When the power switch is turned off, the LCD will show "Poff" first and then the system will shut down and no further messages will be displayed.

## PEAVEY ELECTRONICS CORPORATION LIMITED WARRANTY

Effective Date: 03/04/2010

### What This Warranty Covers

Your Peavey Warranty covers defects in material and workmanship in Peavey products purchased and serviced in the U.S.A. and Canada.

### What This Warranty Does Not Cover

The Warranty does not cover: (1) damage caused by accident, misuse, abuse, improper installation or operation, rental, product modification or neglect; (2) damage occurring during shipment; (3) damage caused by repair or service performed by persons not authorized by Peavey; (4) products on which the serial number has been altered, defaced or removed; (5) products not purchased from an Authorized Peavey Dealer.

### Who This Warranty Protects

This Warranty protects only the original purchaser of the product.

### How Long This Warranty Lasts

The Warranty begins on the date of purchase by the original retail purchaser. The duration of the Warranty is as follows:

Product Category	Duration
Guitars/Basses, Amplifiers, Preamplifiers, Mixers, Electronic Crossovers and Equalizers	2 years *(+ 3 years)
Drums	2 years *(+ 1 year)
Enclosures	3 years *(+ 2 years)
Digital Effect Devices and Keyboards and MIDI Controllers	1 years *(+ 1 year)
Microphones	2 years
Speaker Components (Incl. Speakers, Baskets, Drivers, Diaphragm Replacement Kits and Passive Crossovers)	1 year
Tubes and Meters	90 Days
Cables	Limited Lifetime
Rockmaster Series, Strum'n Fun, Vectra, Rotor, OCC Stage pack, GT & BT Series amps, Retro Fire, Metal Maker and Iron Wing	1 year

[\* Denotes additional Warranty period applicable if optional Warranty Registration Card is completed and returned to Peavey by original retail purchaser within 90 days of purchase.]

### What Peavey Will Do

We will repair or replace (at Peavey's discretion) products covered by Warranty at no charge for labor or materials. If the product or component must be shipped to Peavey for Warranty service, the consumer must pay initial shipping charges. If the repairs are covered by Warranty, Peavey will pay the return shipping charges.

### How To Get Warranty Service

(1) Take the defective item and your sales receipt or other proof of date of purchase to your Authorized Peavey Dealer or Authorized Peavey Service Center.

OR

(2) Ship the defective item, prepaid, to Peavey Electronics Corporation, International Service Center, 412 Highway 11 & 80 East, Meridian, MS 39301. Include a detailed description of the problem, together with a copy of your sales receipt or other proof of date of purchase as evidence of Warranty coverage. Also provide a complete return address.

### Limitation of Implied Warranties

ANY IMPLIED WARRANTIES, INCLUDING WARRANTIES OF MERCHANTABILITY AND FITNESS FOR A PARTICULAR PURPOSE, ARE LIMITED IN DURATION TO THE LENGTH OF THIS WARRANTY.

Some states do not allow limitations on how long an implied Warranty lasts, so the above limitation may not apply to you.

### Exclusions of Damages

PEAVEY'S LIABILITY FOR ANY DEFECTIVE PRODUCT IS LIMITED TO THE REPAIR OR REPLACEMENT OF THE PRODUCT, AT PEAVEY'S OPTION. IF WE ELECT TO REPLACE THE PRODUCT, THE REPLACEMENT MAY BE A RECONDITIONED UNIT. PEAVEY SHALL NOT BE LIABLE FOR DAMAGES BASED ON INCONVENIENCE, LOSS OF USE, LOST PROFITS, LOST SAVINGS, DAMAGE TO ANY OTHER EQUIPMENT OR OTHER ITEMS AT THE SITE OF USE, OR ANY OTHER DAMAGES WHETHER INCIDENTAL, CONSEQUENTIAL OR OTHERWISE, EVEN IF PEAVEY HAS BEEN ADVISED OF THE POSSIBILITY OF SUCH DAMAGES.

Some states do not allow the exclusion or limitation of incidental or consequential damages, so the above limitation may not apply to you.

This Warranty gives you specific legal rights, and you may also have other rights which vary from state to state.

If you have any questions about this Warranty or services received or if you need assistance in locating an Authorized Service Center, please contact the Peavey International Service Center at (601) 483-5365.

Features and specifications are subject to change without notice.

 Logo referenced in Directive 2002/96/EC Annex IV (OJL37/38,13.02.03 and defined in EN 50419: 2005  
The bar is the symbol for marking of new waste and is applied only to equipment manufactured after 13 August 2005



Features and specifications are subject to change without notice.

Peavey Electronics Corporation • 5022 Hartley Peavey Drive • Meridian • MS • 39305  
(601) 483-5365 • FAX (601) 486-1278 • www.peavey.com • ©2011

## Free Manuals Download Website

<http://myh66.com>

<http://usermanuals.us>

<http://www.somanuals.com>

<http://www.4manuals.cc>

<http://www.manual-lib.com>

<http://www.404manual.com>

<http://www.luxmanual.com>

<http://aubethermostatmanual.com>

Golf course search by state

<http://golfingnear.com>

Email search by domain

<http://emailbydomain.com>

Auto manuals search

<http://auto.somanuals.com>

TV manuals search

<http://tv.somanuals.com>