

peerless-AV™

Installation and Assembly: DUKANE PROJECTOR SHORT THROW WALL ARM

Model: UST-WALLARM3

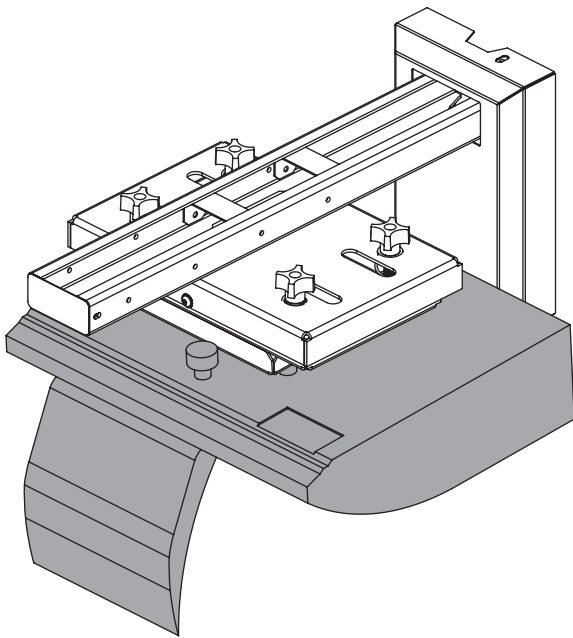

**PROJECTOR POSITION FOR
60" - 70" SCREEN SIZE**

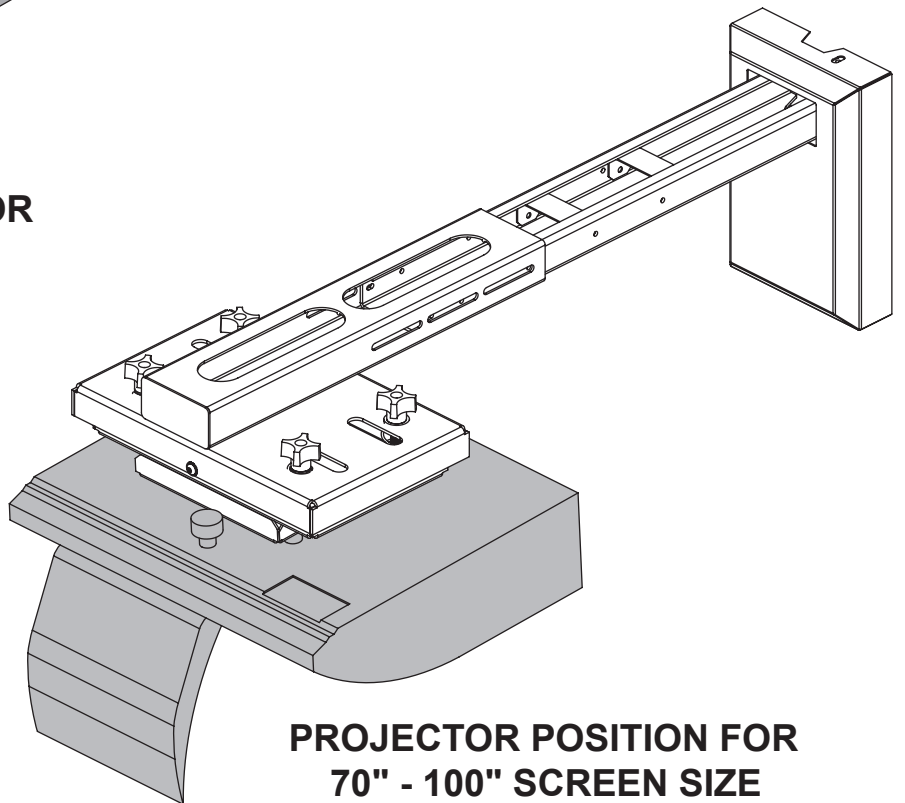

**PROJECTOR POSITION FOR
70" - 100" SCREEN SIZE**

WARNING

- Do not begin to install your Peerless product until you have read and understood the instructions and warnings contained in this Installation Sheet. If you have any questions regarding any of the instructions or warnings, for US customers please call Peerless customer care at 1-800-865-2112, for all international customers, please contact your local distributor.
- This product should only be installed by someone of good mechanical aptitude, has experience with basic building construction, and fully understands these instructions.
- Make sure that the supporting surface will safely support the combined load of the equipment and all attached hardware and components.
- Never exceed the Maximum Load Capacity. See page one.
- If mounting to wood wall studs, make sure that mounting screws are anchored into the center of the studs. Use of an "edge to edge" stud finder is highly recommended.
- Always use an assistant or mechanical lifting equipment to safely lift and position equipment.
- Tighten screws firmly, but do not overtighten. Overtightening can damage the items, greatly reducing their holding power.
- This product is intended for indoor use only. Use of this product outdoors could lead to product failure and personal injury.
- This product was designed to be installed on the following wall construction only;

WALL CONSTRUCTION

HARDWARE REQUIRED

- | | |
|--------------------|--------------------------------|
| • Wood Stud | Included |
| • Wood Beam | Included |
| • Solid Concrete | Included |
| • Cinder Block | Included |
| • Brick | Contact Qualified Professional |
| • Other or unsure? | Contact Qualified Professional |

Tools Needed for Assembly

- stud finder ("edge to edge" stud finder is recommended)
- phillips screwdriver
- drill
- 1/4" bit for concrete and cinder block wall
- 5/32" bit for wood stud wall
- level
- masking tape
- 6 mm allen wrench

Table of Contents

Parts List.....	3
Wall Plate Location Template	4
Installation to Single Wood Stud Wall.....	5
Installation to Solid Concrete and Cinder Block Wall	6
Attaching adapter plate assembly to projector	7
Installation using wall arm bracket	8
Installation using wall arm bracket and extension bracket	9-10
Adjusting the Projector	12-13
Fasten wall arm cover	14

Before you start make sure all parts listed are included with your product.

PARTS LIST		
Description	Qty.	Part #
A adapter plate assembly	1	056-2051
B extension bracket	1	056-2039
C wall arm bracket	1	056-2045
D wall plate	1	056-2046
E wall plate cover	1	056-2047
F projector tilt plate	1	056-2042
G cable management bracket	2	056-2050
H projector attachment bracket	1	056-2048
I shim spacer plate	1	056-2049
J #14 x 2.5" wood screw	4	5S1-015-C04
K concrete anchor	4	590-0230
L M4 x 8 mm socket pin serrated washer head screw	4	510-2005
M M6 x 10 mm socket pin screw	4	520-2255
N #8 x 3/8" sheet metal screw	2	500-2008
O #10 flat black washer	4	540-9400
P M5 x 8 mm pan head black screw	4	570-0005
Q 4mm allen wrench	1	560-9646
R M5 x 20 mm socket pin serrated washer head screw	5	510-2065
S wall arm cap	1	056-2054
T M5 x 10 mm socket pin serrated washer head screw	6	510-2063
U extension cap	1	590-2337

Some parts may appear slightly different than illustrated.

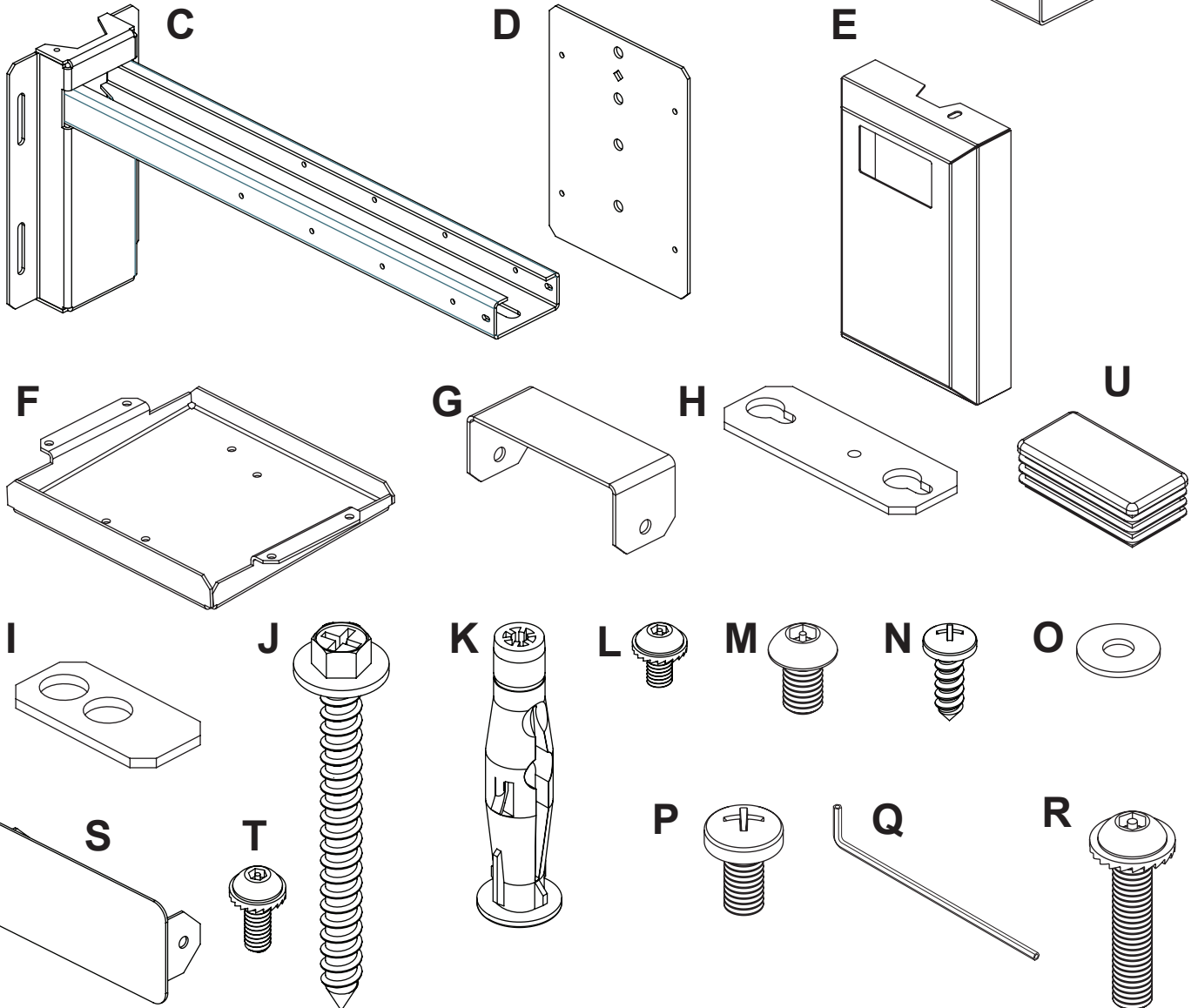
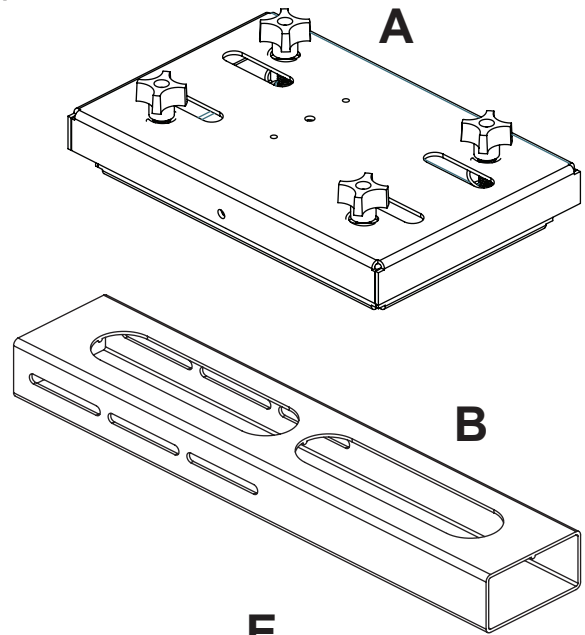

Wall Plate Location

- 1 Determine and mark the top edge of the screen active image.
NOTE: Make sure to leave adequate space above the top edge of the active image for the wall arm and projector to be installed. Approximate dimension (23.0")

Using your mark for the top edge of active image determine dimension B to locate the bottom wall plate (D) mounting hole.

A = Board size / diagonal active image size

B = Distance from the top edge of the active image to the bottom mounting hole of wall plate (D).

C = Distance from the top edge of the active image to the bottom edge of wall plate (D).



MANUFACTURER	MODEL	A	B	C
Hitachi Starboard	Trio 88	88	13.90	11.90
Hitachi Starboard	Trio 77	77	11.68	9.68
Mimio	HD90	88	13.90	11.90
Mimio	Board 80	78	11.82	9.82
Mimio	Board 100	98	14.60	12.60
Polyvision/ENO	TS620	77.8	11.79	9.79
Polyvision/ENO	TSL620	77.8	11.79	9.79
Polyvision/ENO	2610	78	11.82	9.82
Polyvision/ENO	2650	75-16:10	12.00	10.00
Polyvision/ENO	2650	75-4:3	11.40	9.40
Polyvision/ENO	2810	96	15.10	13.10
Polyvision/ENO	2850	93-16:10	14.65	12.65
Polyvision/ENO	2850	93-4:3	13.85	11.85
Promethean	587 Pro	87	13.75	11.75
Promethean	387	87	13.75	11.75
Promethean	387 Pro	87	13.75	11.75
Promethean	595 Pro	95	14.95	12.95
Promethean	395	95	14.95	12.95
Promethean	395 Pro	95	14.95	12.95
Promethean	164	64	9.86	7.86
Promethean	378	78	11.82	9.82
Promethean	378 Pro	78	11.82	9.82
Promethean	178	78	11.82	9.82
Smart	885	87	13.75	11.75
Smart	685	87.13	13.76	11.76
Smart	690	94	14.80	12.80
Smart	660	64	9.86	7.86
Smart	880	77	11.68	9.68
Smart	680	77	11.68	9.68

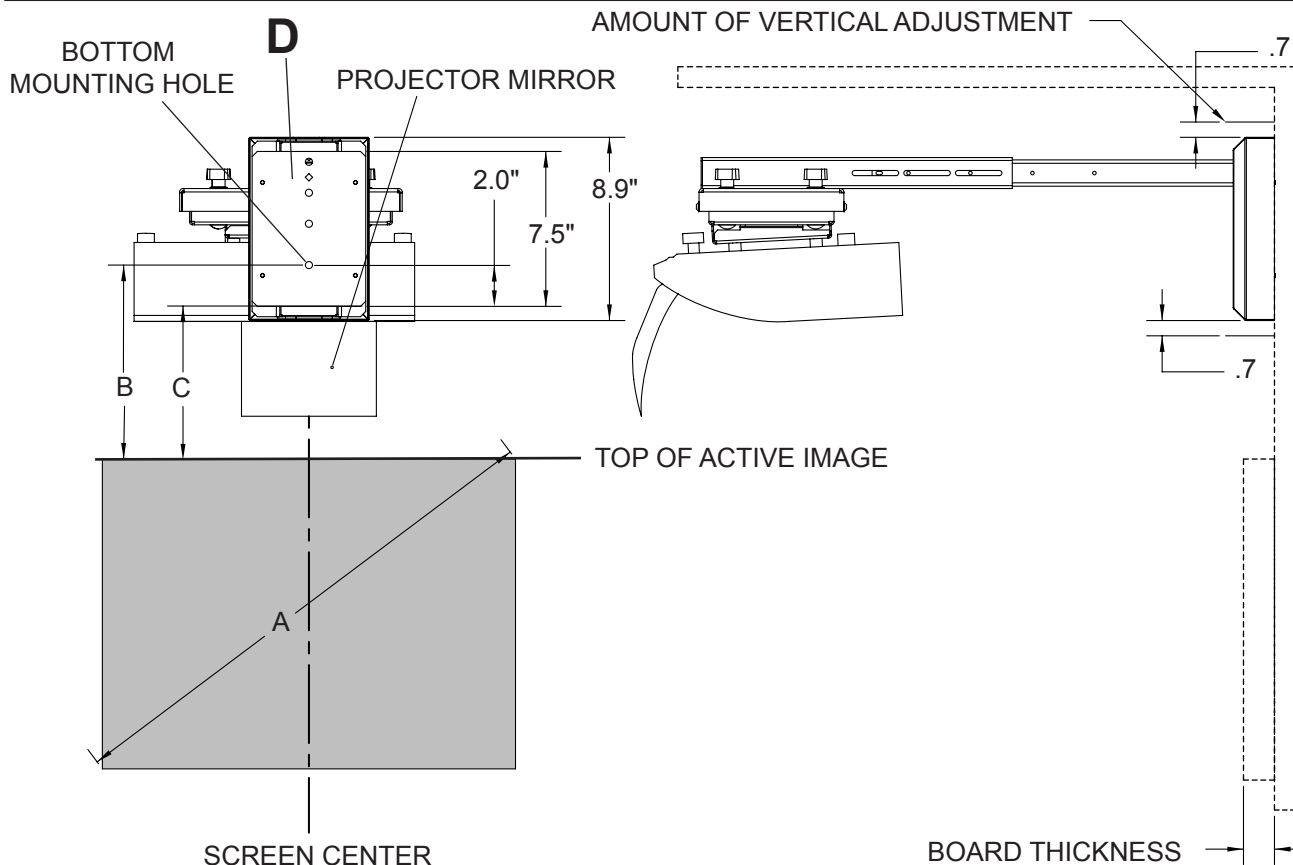

Installation to Single Wood Stud Wall

⚠ WARNING

- Installer must verify that the supporting surface will safely support the combined load of the equipment and all attached hardware and components.
- Tighten wood screws so that wall plate is firmly attached, but do not overtighten. Overtightening can damage the screws, greatly reducing their holding power.
- Never tighten in excess of 80 in. • lb (9 N.M.).
- Make sure that mounting screws are anchored into the center of the stud. The use of an "edge to edge" stud finder is highly recommended.
- Hardware provided is for attachment of mount through standard thickness drywall or plaster into wood studs. Installers are responsible to provide hardware for other types of mounting situations.

- 1 Using wall plate (D) as a template, drill four 5/32" (4 mm) dia. holes to a minimum depth of 2.5" (64 mm). Attach wall plate (D) to centers of wood studs using four #14 x 2.5" wood screws (J) shown in figure 1.1. Fasten wall arm bracket (C) loosely to wall plate (D) using four M5 x 8 mm pan head black screws (P), and four #10 black washers (O).

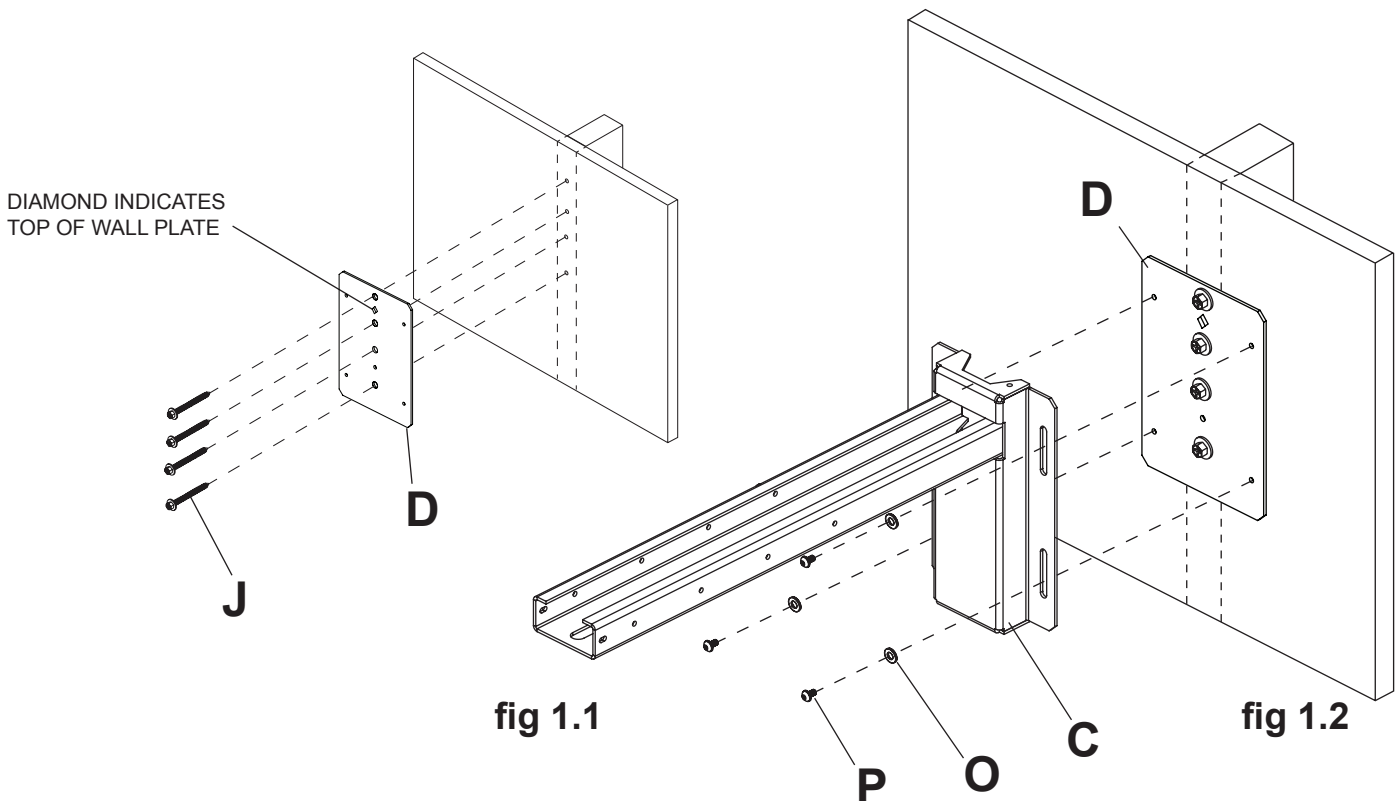

Installation to Solid Concrete or Cinder Block

⚠ WARNING

- When installing Peerless wall mounts on cinder block, verify that you have a minimum of 1-3/8" (35 mm) of actual concrete thickness in the hole to be used for the concrete anchors. Do not drill into mortar joints! Be sure to mount in a solid part of the block, generally 1" (25 mm) minimum from the side of the block. Cinder block must meet ASTM C-90 specifications. It is suggested that a standard electric drill on slow setting is used to drill the hole instead of a hammer drill to avoid breaking out the back of the hole when entering a void or cavity.
- Concrete must be 2000 psi density minimum. Lighter density concrete may not hold concrete anchor.
- Make sure that the wall will safely support four times the combined load of the equipment and all attached hardware and components.

- 1** Make sure that wall arm bracket (C) is level, use it as a template to mark four mounting holes. Drill four 5/16" (8 mm) dia. holes to a minimum depth of 2.5" (64 mm). Insert concrete anchors (K) in holes flush with wall as shown (right). Place wall arm bracket over anchors and secure with #14 x 2.5" screws (J). Level, then tighten all fasteners.

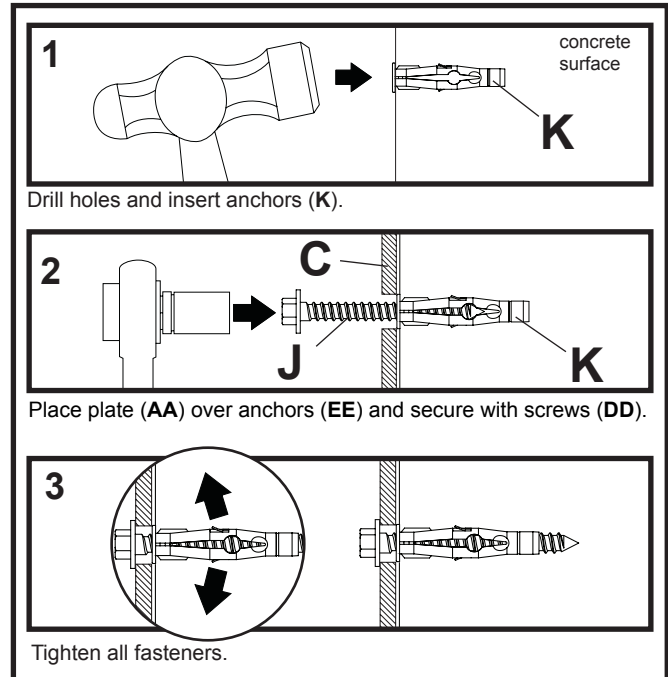

⚠ WARNING

- Tighten screws so that wall plate is firmly attached, but do not overtighten. Overtightening can damage screws, greatly reducing their holding power.
- Never tighten in excess of 80 in. • lb (9 N.M.).
- Always attach concrete expansion anchors directly to load-bearing concrete.
- Never attach concrete expansion anchors to concrete covered with plaster, drywall, or other finishing material. If mounting to concrete surfaces covered with a finishing surface is unavoidable, the finishing surface must be counterbored as shown below. Be sure concrete anchors do not pull away from concrete when tightening screws. If plaster/drywall is thicker than 5/8" (16 mm), custom fasteners must be supplied by installer.

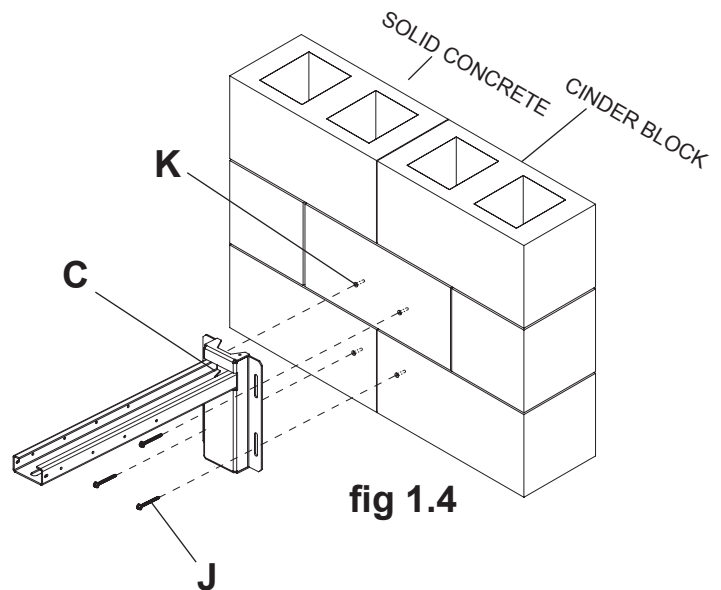
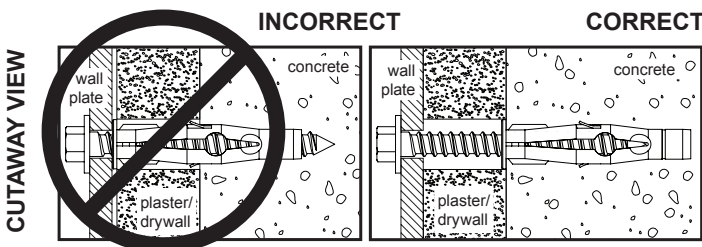

2 Remove knobs and M10 washers from top of adapter plate assembly (A).

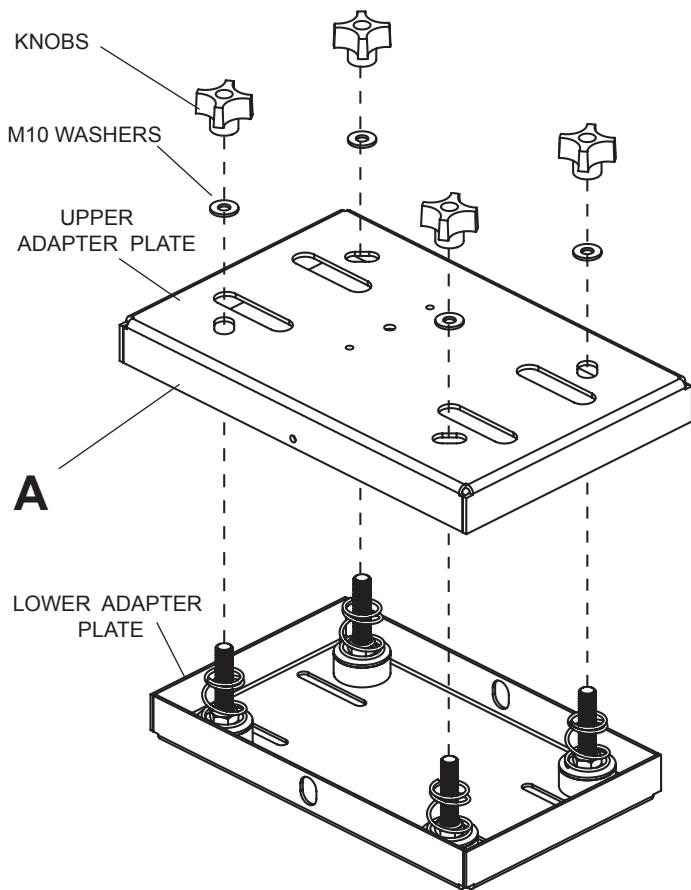

3 Place projector tilt plate (F) onto projector and secure using four M4 x 8 mm socket pin serrated washer head screws (L).

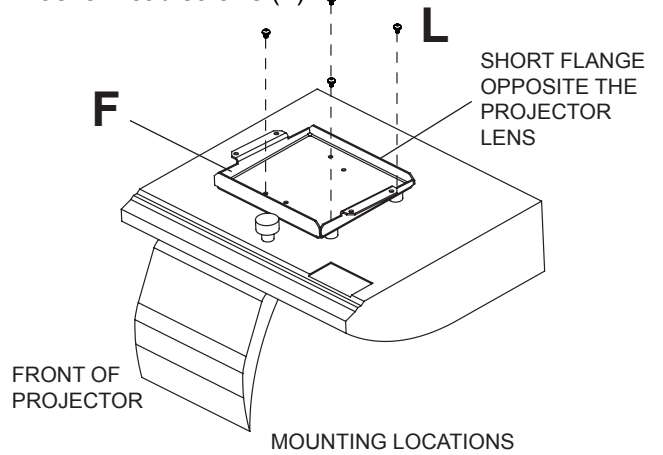

4 Secure lower adapter plate onto projector tilt plate (F) using four M6 x 10 mm socket pin screws (M). Re-fasten knobs and M10 washers from top of adapter plate assembly (A).

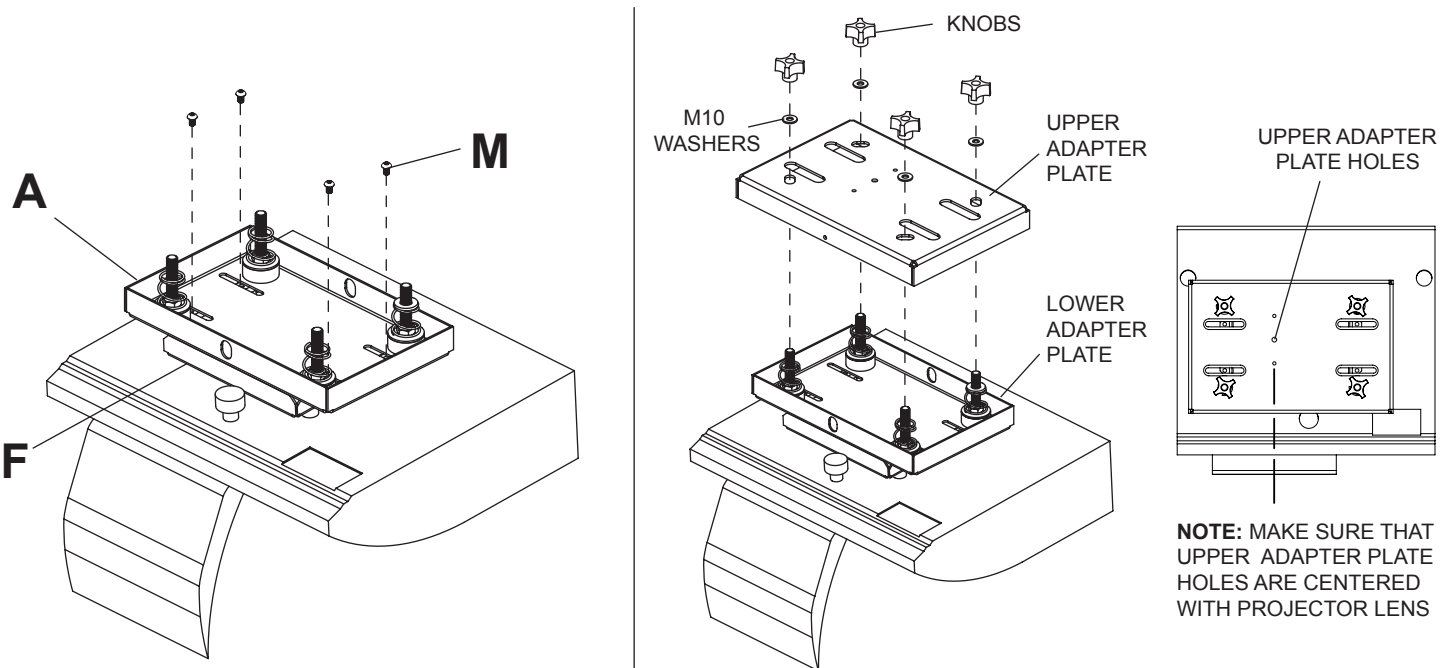

- 5** Fasten two M5 x 20 mm socket pin serrated washer head screws (R) into top of adapter plate assembly (A) leaving 3/8" of exposed thread as shown below.

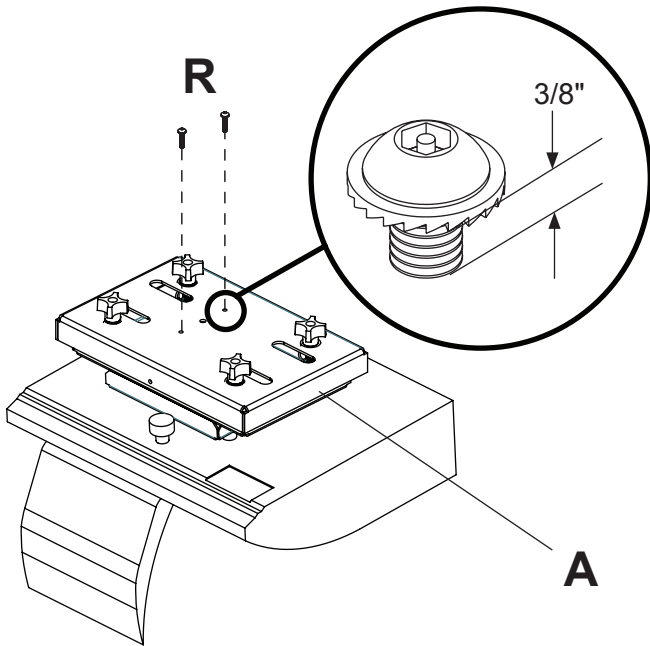

- 6** Fasten one M5 x 20 mm socket pin serrated washer head screws (R) into top of projector attachment bracket (H) leaving no exposed thread on bottom of bracket as shown below.

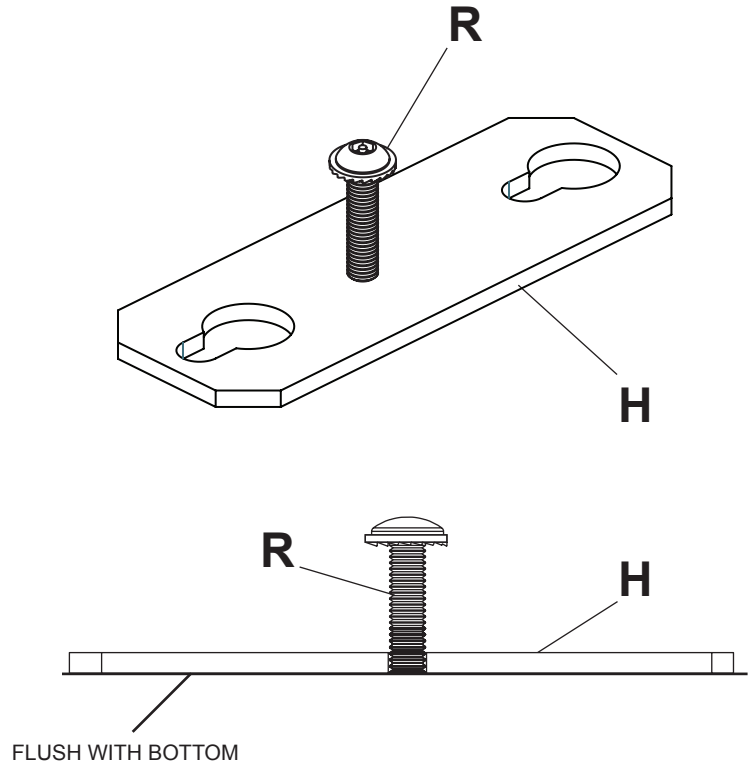

- 7** Slide two cable management brackets (G) into channel in wall arm bracket (C) as shown below. Slide wall plate cover (E) onto wall arm bracket (C).

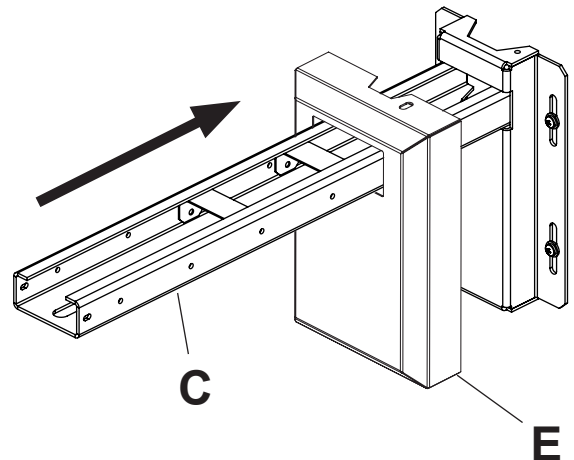
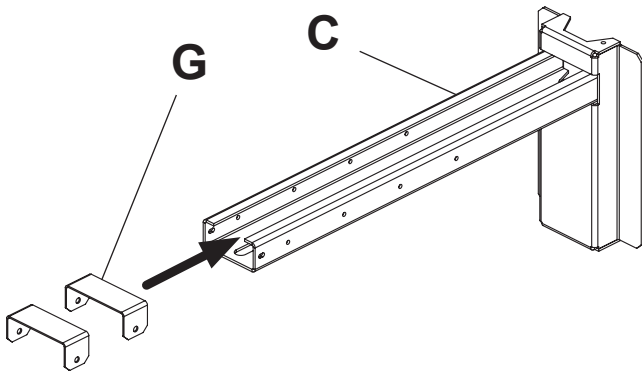

- 8** Select projector mount orientation.

Option 1 - PROJECTOR POSITION FOR 60" - 70" SCREEN SIZE.....PAGE 8

Option 2 - PROJECTOR POSITION FOR 70" - 100" SCREEN SIZE.....PAGE 9

PROJECTOR POSITION FOR 60" - 70" SCREEN SIZE

SKIP TO PAGE 9 IF MOUNTING WITH 70" - 100" SCREEN SIZE

Installation using Wall Arm Bracket

- 9** Attach exposed M5 x 20 mm socket pin serrated washer head screws (**R**) on top of adapter plate assembly (**A**) through slot in wall arm bracket (**C**) and keyholes in projector attachment bracket (**H**) as shown in detail 1. Slide projector attachment bracket (**H**) toward wall. Once in locked position tighten all three M5 x 20 mm socket pin serrated washer head screws (**R**) using security wrench (**Q**) as shown in detail 2.

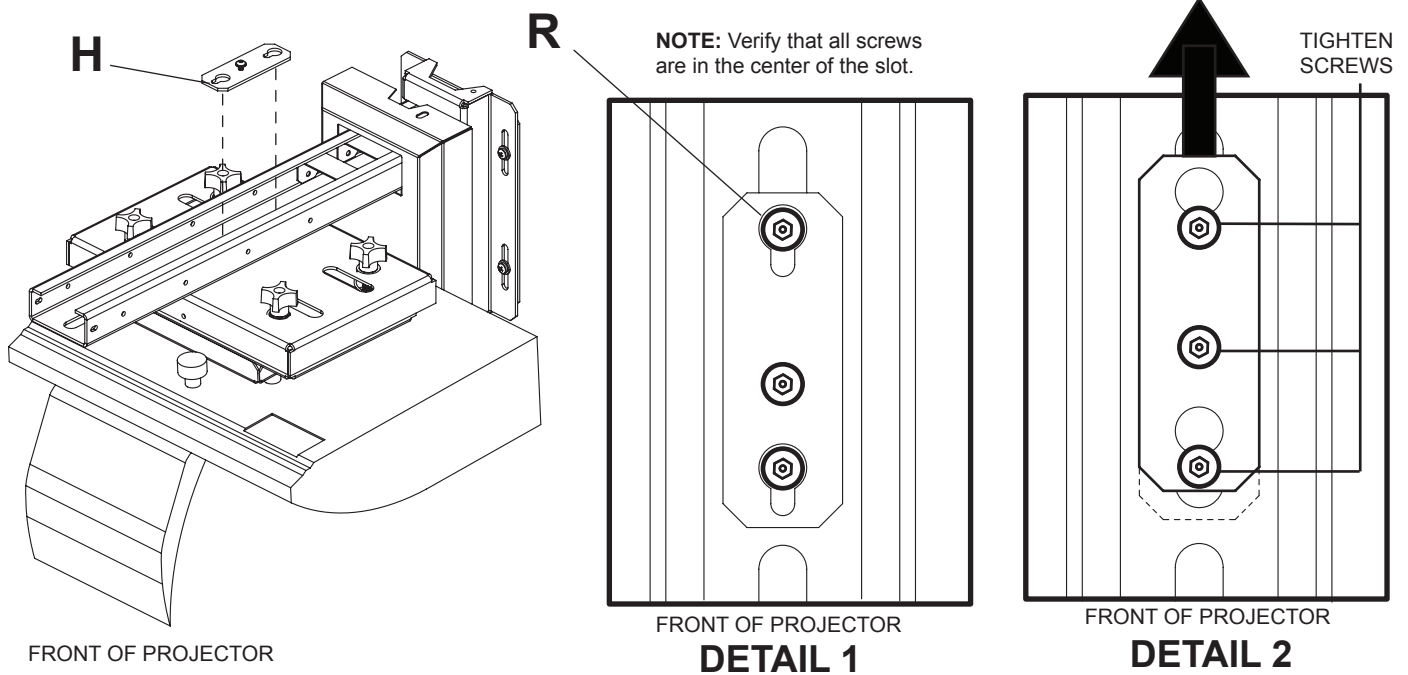

- 10** Secure wall arm cap (**S**) into wall arm bracket (**C**) using two #8 x 3/8" sheet metal screws (**N**). Route projector cables as shown. Use two cable management brackets (**G**) as needed.
- NOTE:** #8 x 3/8" sheet metal screws (**N**) will be shortened for production.
- Fasten two M5 x 20 mm socket pin serrated washer head screws (**R**) into top of adapter plate assembly (**A**).
SKIP TO PAGE 11.

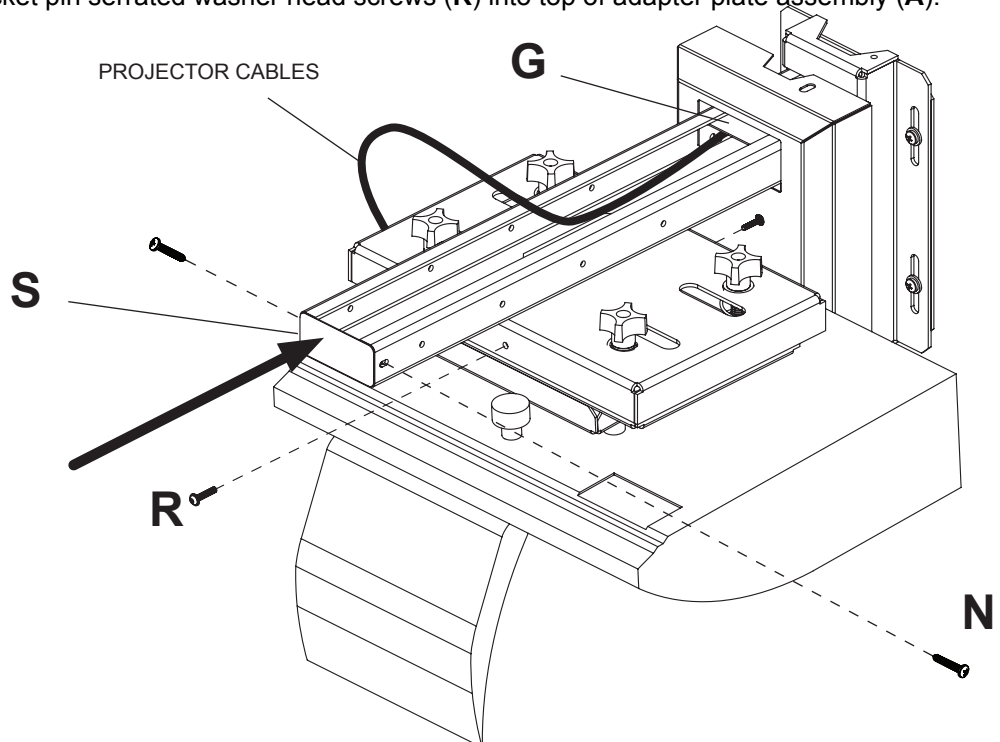

PROJECTOR POSITION FOR 70" - 100" SCREEN SIZE

Installation using Wall Arm Bracket and Extension Bracket

- 9** Snap extension cap (U) into extension bracket (B) in orientation as shown in figure 9.1.
 Slide wall plate cover (E) onto wall arm bracket (C).
 Slide extension bracket (B) into wall arm bracket (C) in desired position.

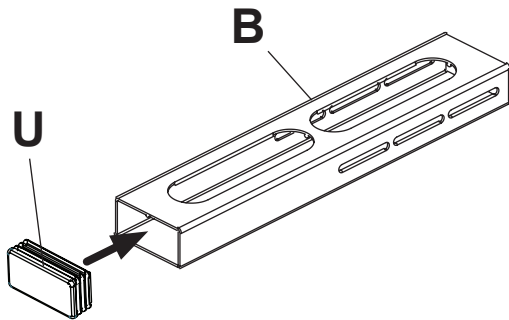

FIGURE 9.1

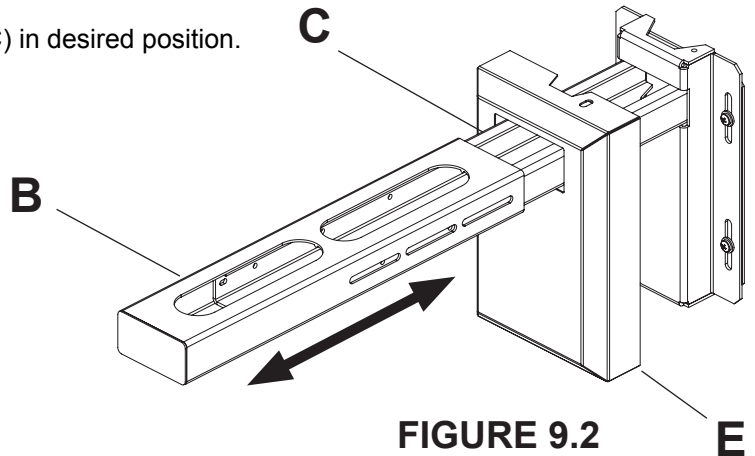

FIGURE 9.2

10 Requirements for Shim Spacer

1. When the front pre-fastened M5 x 20 mm socket pin serrated washer head screw (R) of the adapter plate assembly (A) goes through the extension bracket (B) and wall arm bracket (C).
2. When there is a gap between the bottom of the projector attachment bracket (H) and the extension bracket (B).

NOTE: If Shim spacer plate (I) is not required skip to step 11

Position exposed M5 x 20 mm socket pin serrated washer head screws (R) through slot in extension bracket (B) and wall arm bracket (C). Position screws in keyholes in projector attachment bracket (H), and hole in shim spacer plate (I) as shown in detail 3. Slide projector attachment bracket (H) toward wall. Once in locked position tighten all three M5 x 20 mm socket pin serrated washer head screws (R) using security wrench (Q) as shown in detail 4. Secure extension bracket (B) into wall arm bracket (C) and secure using four M5 x 10 mm socket pin screws (T) in desired position. **NOTE:** Make sure that four M5 x 10 mm socket pin screws (T) are used. SKIP TO STEP 12.

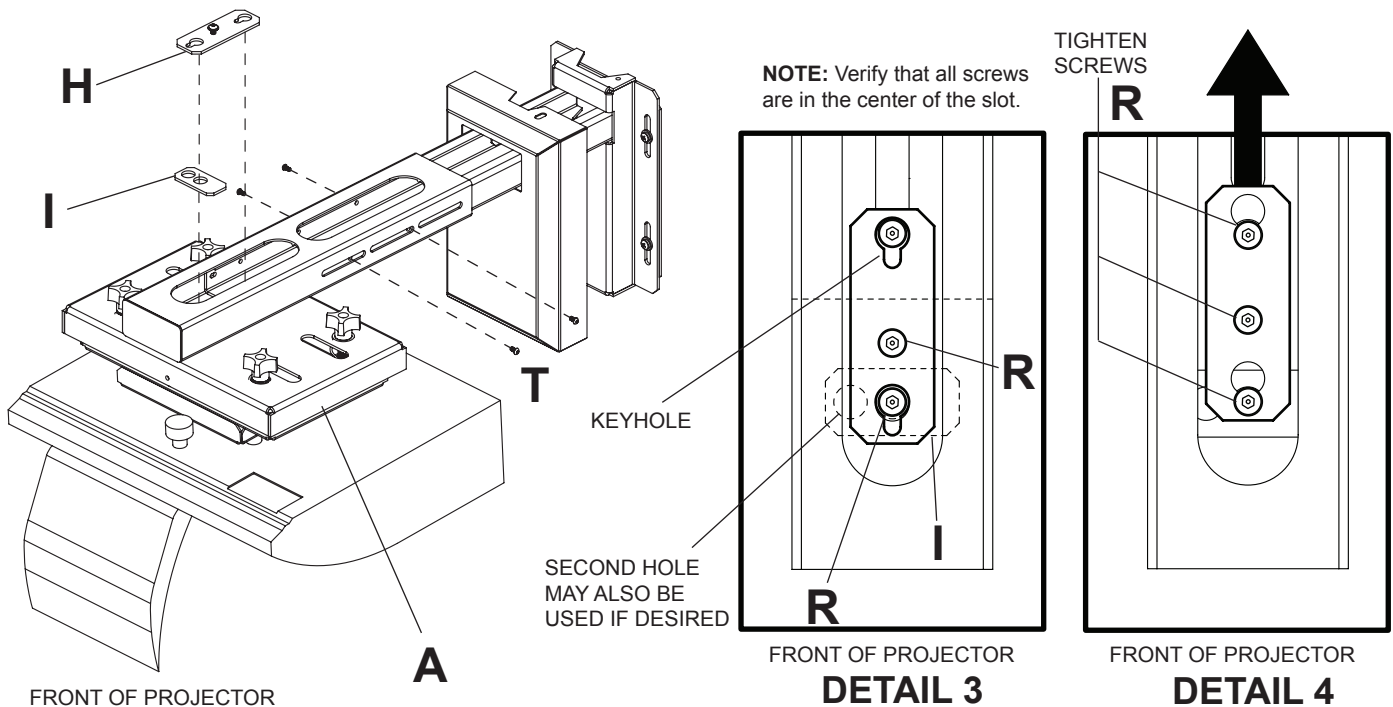

Installation using Wall Arm Bracket and Extension Bracket

- 11** Attach exposed M5 x 20 mm socket pin serrated washer head screws (R) into top of adapter plate assembly (A) through slot in extension bracket (B) and keyholes in projector attachment bracket (H) as shown in detail 5. Slide projector attachment bracket (H) toward wall. Once in locked position tighten all three M5 x 20 mm socket pin serrated washer head screws (R) using security wrench (Q) as shown in detail 6. Secure extension bracket (B) into wall arm bracket (C) and secure using four M5 x 10 mm socket pin screws (T) using security wrench (Q) in desired position. **NOTE:** Make sure that four M5 x 10 mm socket pin screws (T) are used.

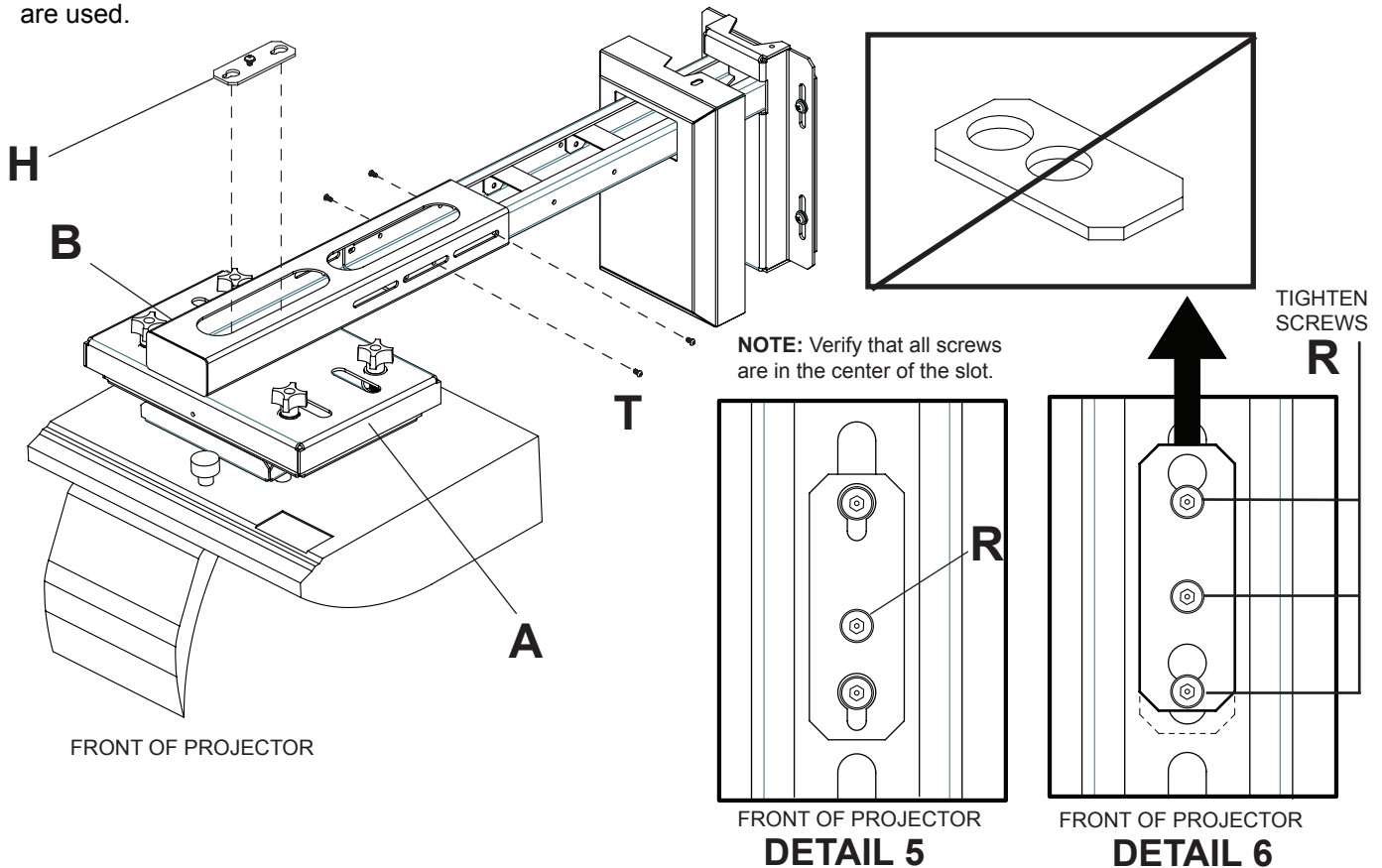

- 12** Route projector cables as shown. Use two cable management brackets (G) as needed. Fasten two M5 x 20 mm socket pin serrated washer head screws (R) into top of adapter plate assembly (A).

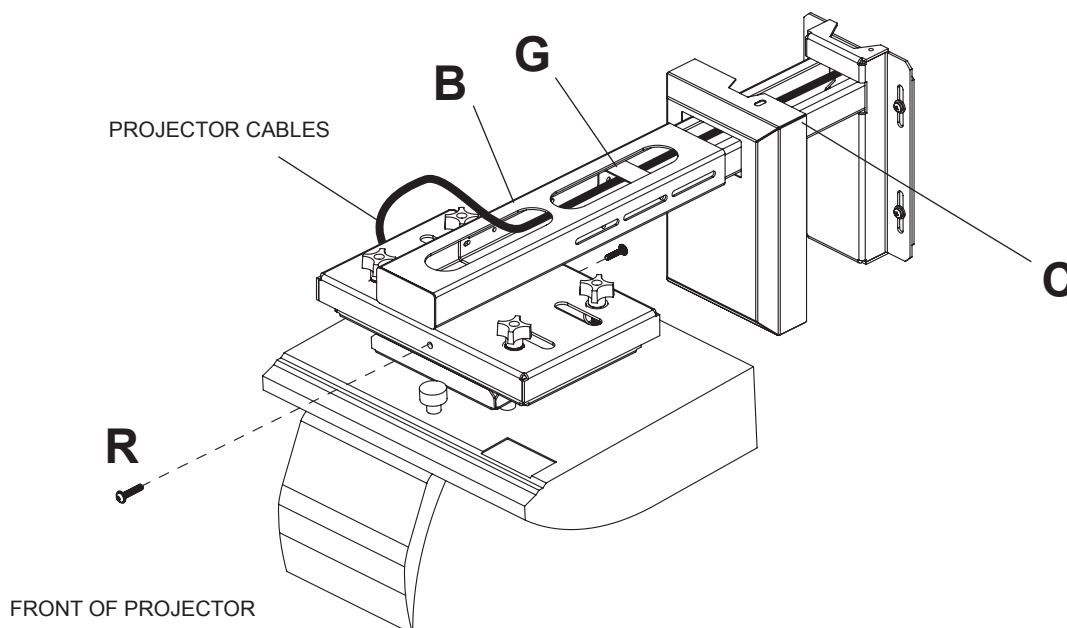

Roll Adjustment

- 14** Loosen knobs on left side of projector, and tighten knobs on right side of projector to roll projector to the right. Reverse for projector roll to the left.

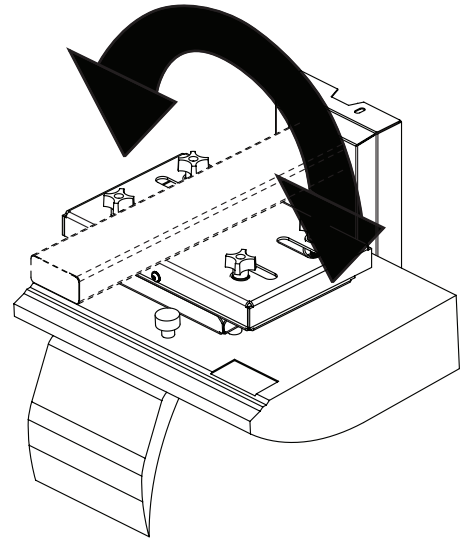
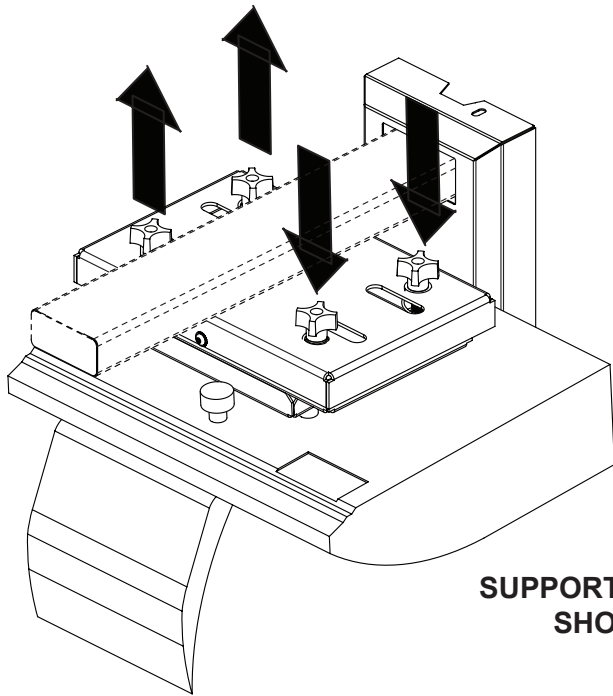
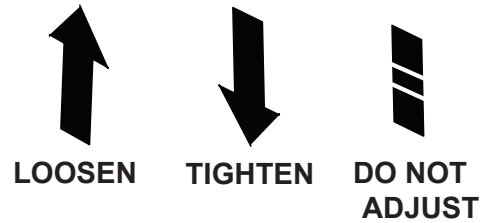

Pitch Adjustment

- Loosen knobs on front of projector, and tighten knobs on back of projector to pitch projector forward. Reverse for projector to pitch backward.

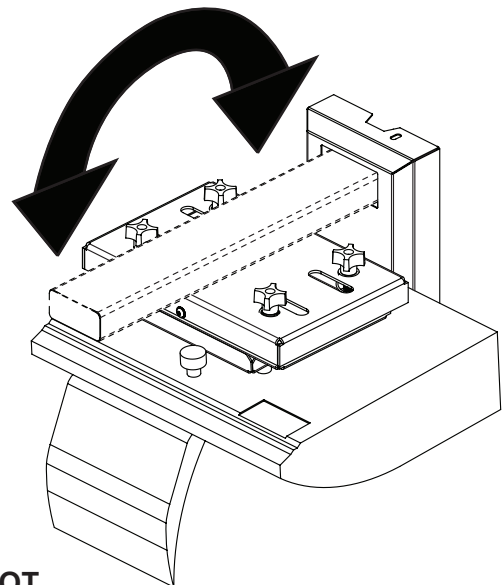
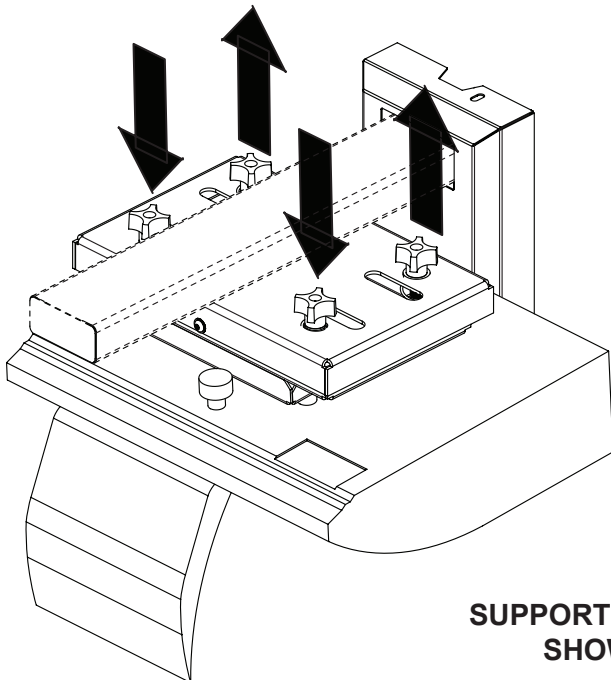
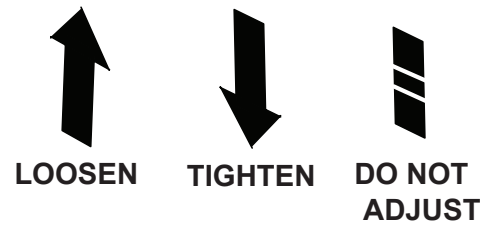

Combination for Pitch and Roll Rotation

Tighten knob on back right of projector, and loosen knob on left front of projector to pitch and rotate projector backward to the right as shown in fig. 13.1. Reverse for projector to pitch backward to the left.

Loosen knob on back right of projector, and tighten knob on left front of projector to pitch and rotate projector backward to the right as shown in fig. 13.2. Reverse for projector to pitch backward to the left.

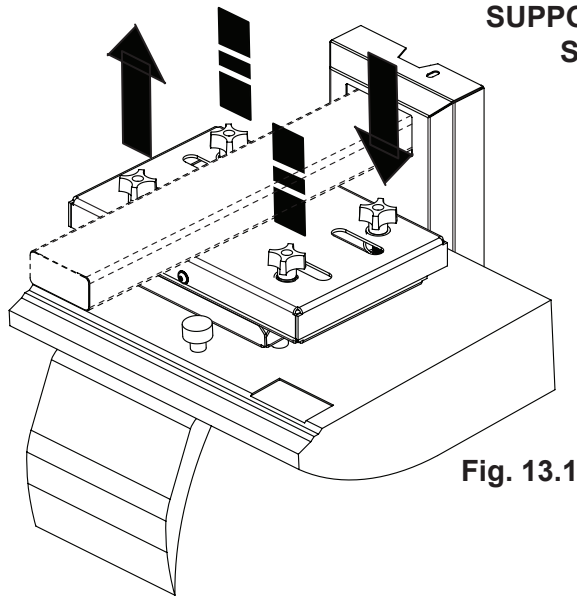

SUPPORTING SURFACE NOT SHOWN FOR CLARITY

Fig. 13.1

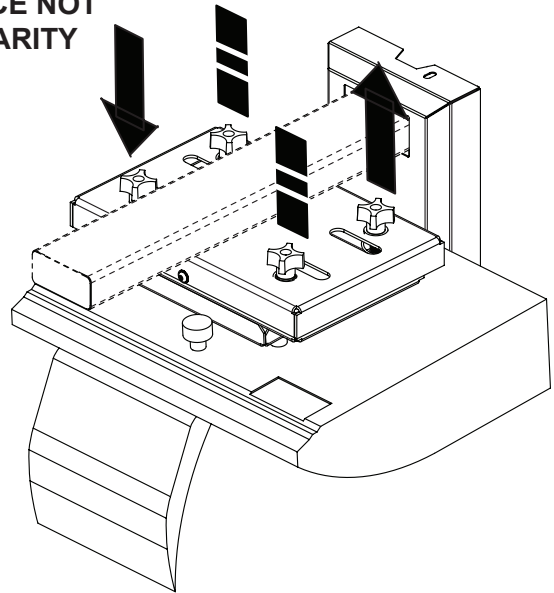

NOTE: For more adjustment, knobs can be turned individually

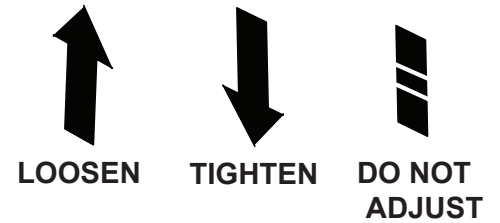

Swivel Adjustment

Grip sides of projector and gently rotate to desired position.

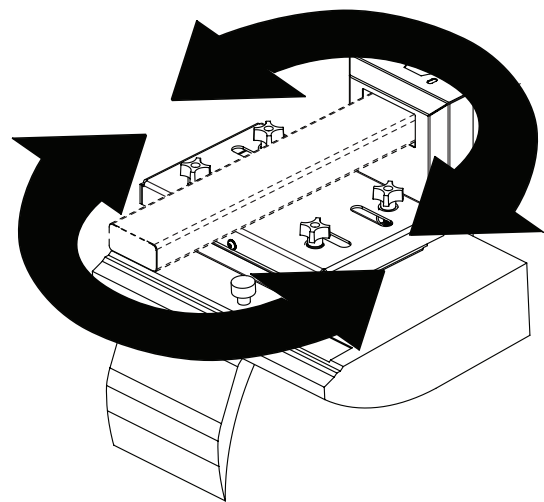
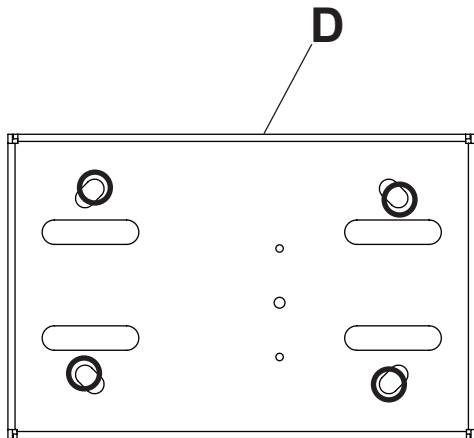

SUPPORTING SURFACE NOT SHOWN FOR CLARITY

- 14** Secure wall plate cover (E) to wall arm bracket (C) using two M5 x 10 mm socket pin serrated washer head screws (T).

Note: Adjust height of wall plate prior to fastening wall plate cover (E) for projector image location. Use security wrench (Q) to fasten screws.

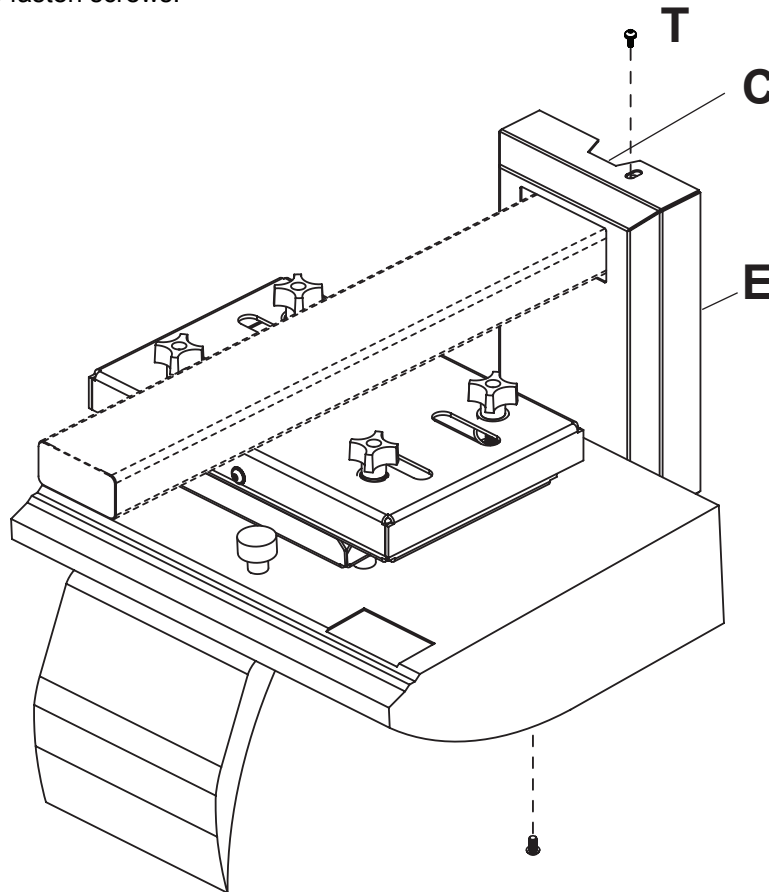

**SUPPORTING SURFACE NOT
SHOWN FOR CLARITY**

Free Manuals Download Website

<http://myh66.com>

<http://usermanuals.us>

<http://www.somanuals.com>

<http://www.4manuals.cc>

<http://www.manual-lib.com>

<http://www.404manual.com>

<http://www.luxmanual.com>

<http://aubethermostatmanual.com>

Golf course search by state

<http://golfingnear.com>

Email search by domain

<http://emailbydomain.com>

Auto manuals search

<http://auto.somanuals.com>

TV manuals search

<http://tv.somanuals.com>