

**PMC21A  
21-Inch Color Monitor**

**Installation/  
Operation Manual**

**C1959M (6/99)**

Pelco • 3500 Pelco Way • Clovis, CA 93612-5699 USA • [www.pelco.com](http://www.pelco.com)  
In North America and Canada: Tel (800) 289-9100 or FAX (800) 289-9150  
International Customers: Tel (1-559) 292-1981 or FAX (1-559) 348-1120

## CONTENTS

<b>Section</b>	<b>Page</b>
IMPORTANT SAFEGUARDS AND WARNINGS .....	3
DESCRIPTION .....	3
INSTALLATION .....	3
OPERATION .....	5
FRONT PANEL CONTROLS .....	5
PASSIVE LOOPING .....	5
MAINTENANCE .....	6
SPECIFICATIONS .....	6
WARRANTY AND RETURN INFORMATION .....	8

## LIST OF ILLUSTRATIONS

<b>Figure</b>	<b>Page</b>
1 Bezel Rack Mount Installation .....	3
2 Rear Panel Connections .....	4
3 One Monitor with External Video Equipment .....	4
4 Monitor Looping with External Video Equipment .....	4
5 S-VHS Video (Y/C) Input Connections .....	5
6 Front Panel Controls .....	5
7 PMC21A Dimension Drawing .....	7
8 Bezel Rack Mount Dimension Drawing .....	7

## LIST OF TABLES

<b>Table</b>	<b>Page</b>
A Video Coaxial Cable Requirements .....	4

## IMPORTANT SAFEGUARDS AND WARNINGS

Observe the following warnings before installing and using this product.

1. Installation and servicing should be done by qualified installation and service personnel only.
2. Installation should be done according to all local and national electrical and mechanical codes, using only approved materials.
3. Use only installation methods and materials capable of supporting four times the maximum specified load.
4. A CCC-approved power cord must be used to power this equipment when used in China.

Please thoroughly familiarize yourself with the information in this manual prior to installation and operation.

## DESCRIPTION

The PMC21A is a high-resolution color monitor that can be used in desktop applications or rack mounted using the bezel rack mount that is provided as a standard accessory. The rack mount is constructed of steel, has a black finish, and occupies 11 rack unit spaces. It is supplied with eight flat-head screws to attach the rack mount to the monitor, and four 10-32 screws to attach the rack mount to a console.

The monitor supports NTSC and PAL video, as well as 120 VAC and 230 VAC input power. An automatic switching system makes all the necessary changes for adapting to the required formats. Manual selection is not required. A separate power cord is supplied for each voltage input.

The PMC21A features audio input and output, and has a steel housing and front panel controls. The S-VHS high-resolution video (420 horizontal lines at center) and digital comb filter circuitry add to the superior picture quality.

## INSTALLATION



**CAUTION:** Do not install this monitor in a location having excessive heat or in any way that obstructs the ventilation openings in the cabinet. Premature component failure or cabinet damage may result.

**NOTE:** Installation of the monitor and rack mount into the console may require two persons.

To install the monitor in a rack, start at step 1. Otherwise, start at step 3.

1. Slide the bezel rack mount onto the monitor from the rear and attach it to the monitor with the eight M5 flat-head screws provided.
2. Place the PMC21A monitor and rack mount into the console, align the mounting holes of the rack mount with the mounting holes in the console, and insert and tighten the four 10-32 screws provided. The face of the monitor protrudes approximately 4.8 inches (12.2 cm) from the front of the rack.

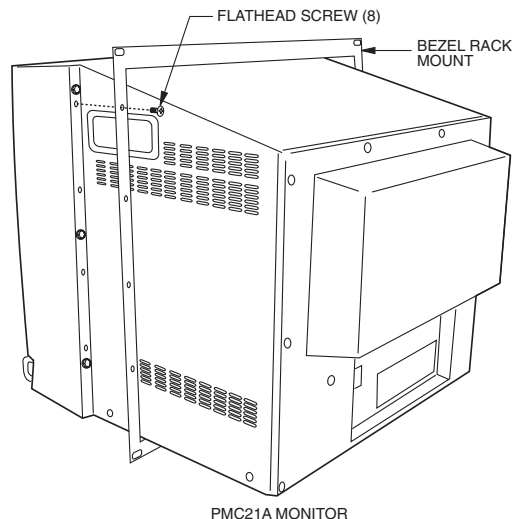

Figure 1. Bezel Rack Mount Installation

- Connect the equipment as shown in Figures 2 through 5. Refer to Table A for the type of video coaxial cable to use.

**Table A. Video Coaxial Cable Requirements**

Cable Type*	Maximum Distance
RG59/U	750 ft (229 m)
RG6/U	1,000 ft (305 m)
RG11/U	1,500 ft (457 m)

\*Minimum cable requirements:  
 75 ohms impedance  
 All-copper center conductor  
 All-copper braided shield with 95% braid coverage

- Set the IMPEDANCE switch on the monitor(s) to HIGH if the VIDEO OUT connection is used. Otherwise, set the switch(es) to the 75-OHM position.
- Plug the appropriate power cord into the AC INLET connection on the rear panel of the monitor (refer to Figure 2). Plug the other end into a power receptacle.

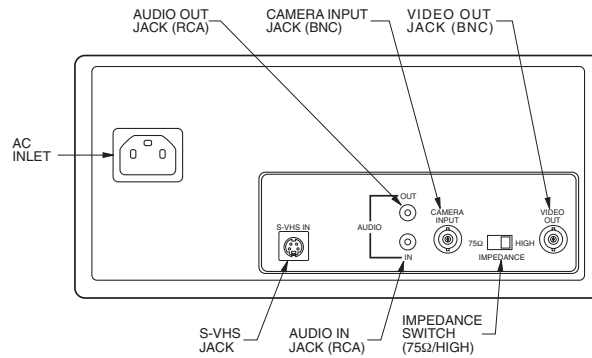

**Figure 2. Rear Panel Connections**

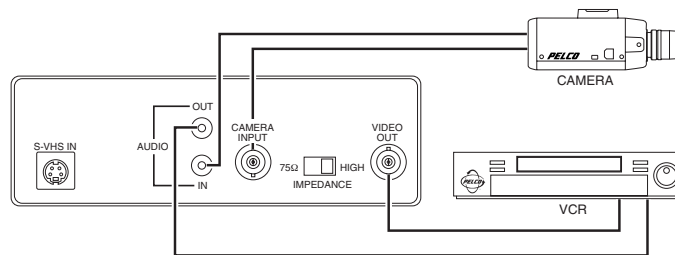

**Figure 3. One Monitor with External Video Equipment**

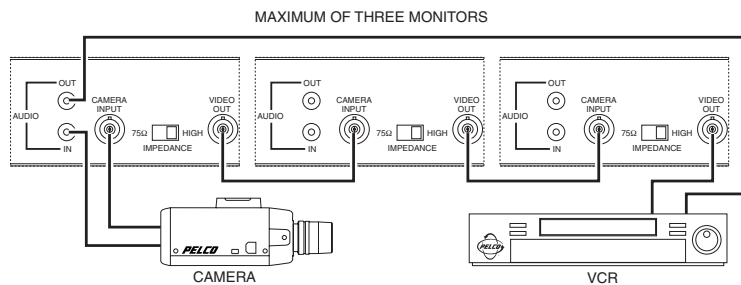

**Figure 4. Monitor Looping with External Video Equipment**

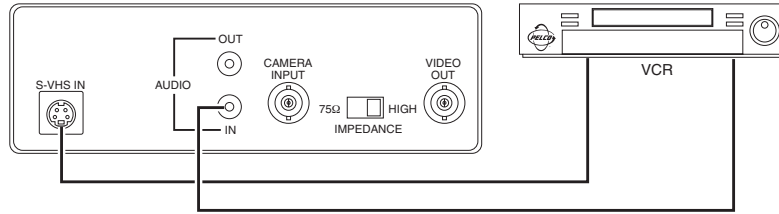

Figure 5. S-VHS Video (Y/C) Input Connections

## OPERATION

### FRONT PANEL CONTROLS

Refer to Figure 6 for front panel controls.

1. Press the POWER switch to turn the monitor on. The power LED lamp above the switch will illuminate when the power is applied.
2. Press the VIDEO/S-VHS switch to select the S-VHS mode if the S-VHS input jack on the rear of the monitor is used. Otherwise, select the VIDEO mode. The mode is momentarily displayed on the upper right portion of the monitor screen at the time it is selected.
3. Adjust the VOLUME control for the desired audio level. Turn the control clockwise to increase and counterclockwise to decrease.
4. Adjust the CONT. control for the desired overall contrast. Proper adjustment will allow maximum gradations between the darkest and lightest picture contrast. Turn the control clockwise to increase and counterclockwise to decrease.
5. Adjust the BRIGHT control for the desired overall display brightness. This control is also useful to compensate for differences in surrounding area lighting. Turn the control clockwise to increase and counterclockwise to decrease.
6. Adjust the COLOR control to set the color saturation level. Turn the control clockwise to increase and counterclockwise to decrease.
7. Adjust the SHARP control to obtain the clearest picture.
8. Adjust the TINT control for the proper color phase or flesh tones. When turned clockwise, the skin tone becomes greenish. When turned counterclockwise, skin tone becomes reddish.

### PASSIVE LOOPING

Passive looping is accomplished when two or three monitors are connected in series (see Figure 4) and a looping signal is sent through the IN and OUT connectors of one monitor and to the next in series. Unless you want to view the monitor(s), none of them need to be turned on for passive looping to function.

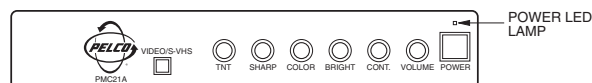

Figure 6. Front Panel Controls

## MAINTENANCE

If the quality of the picture is poor and cannot be improved by making adjustments on the front control panel, inspect all system connections and cable runs.

To reduce the risk of electrical shock, do not remove the cover or the back. No user-serviceable parts are inside. Refer servicing to qualified personnel or contact the Pelco Customer Service Department for assistance. Refer to the *Warranty and Return Information* section.

Clean the cabinet with a cloth slightly dampened with mild household detergent only. Use a soft cloth for drying. Some household aerosol sprays, cleaning agents, solvents, or polishes may damage the cabinet finish. Never use strong solvents such as thinner or benzene.

## SPECIFICATIONS

### **ELECTRICAL**

Input Voltage: 110-240 VAC, 50/60 Hz

Power Consumption: 70 watts

Horizontal Resolution: 420 lines (center)  
300 lines (corners)

Picture Tube: 21.0 inches (53.34 cm) measured diagonally

Viewable Picture Size: 20.5 inches (52.07 cm) measured diagonally

Input Signal: Composite video, negative sync  
Y: 1.0 Vp-p  
C: 0.286 Vp-p

#### Terminals

Video Input Level/  
Impedance: 1.0 Vp-p/75 ohms  
Video Output Level/  
Impedance: 1.0 Vp-p/75 ohms  
Audio Input Level/  
Impedance: 0.3 Vrms/25K ohms (over)  
Audio Output Level/  
Impedance: 0.3 Vrms/4.7K ohms (under)

#### Subcarrier Frequency

Sync Range: 3.579549 MHz  $\pm$ 200 Hz  
4.433619 MHz  $\pm$ 200 Hz at room temperature

High Voltage: 25  $\pm$ 1.2 kV

### **GENERAL**

#### Connectors

Camera Input/  
Video Output: BNC  
S-VHS Input: 4-pin mini DIN  
Audio Input/  
Output: RCA

AC Power Cord: One power cord with grounded plug for 120 VAC  
One "Euro"-style grounded power cord for 230 VAC

**Construction**  
 Monitor: Steel cabinet  
 Bezel  
 Rack Mount: Steel

**Finish**  
 Monitor: Black with black bezel around screen  
 Bezel  
 Rack Mount: Black

**Dimensions**  
 Monitor: See Figure 7  
 Bezel  
 Rack Mount: See Figure 8

Unit Weight: 52 lb (23.6 kg)

**ENVIRONMENTAL**

**Operating**  
 Temperature: 32° to 106°F (0° to 41°C)  
 Humidity: 10% to 95% (non-condensing)

*(Design and product specifications subject to change without notice.)*

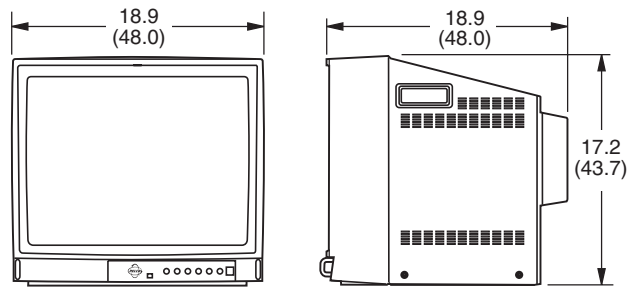

**NOTE:** VALUES IN PARENTHESES ARE CENTIMETERS; ALL OTHERS ARE INCHES

**Figure 7.** PMC21A Dimension Drawing

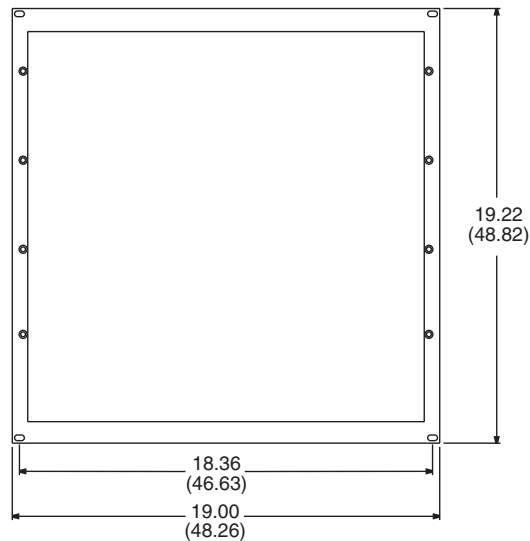

**NOTE:** VALUES IN PARENTHESES ARE CENTIMETERS; ALL OTHERS ARE INCHES

**Figure 8.** Bezel Rack Mount Dimension Drawing

## PRODUCT WARRANTY AND RETURN INFORMATION

### WARRANTY

Pelco will repair or replace, without charge, any merchandise proved defective in material or workmanship **for a period of one year** after the date of shipment.

Exceptions to this warranty are as noted below:

- Five years on FT/FR8000 Series fiber optic products.
- Three years on Genex® Series products (multiplexers, server, and keyboard).
- Three years on Camclosure® and fixed camera models, except the CC3701H-2, CC3701H-2X, CC3751H-2, CC3651H-2X, MC3651H-2, and MC3651H-2X camera models, which have a five-year warranty.
- Two years on standard motorized or fixed focal length lenses.
- Two years on Legacy®, CM6700/CM6800/CM9700 Series matrix, and DF5/DF8 Series fixed dome products.
- Two years on Spectra®, Esprit®, ExSite™, and PS20 scanners, including when used in continuous motion applications.
- Two years on Esprit® and WW5700 Series window wiper (excluding wiper blades).
- Eighteen months on DX Series digital video recorders, NVR300 Series network video recorders, and Endura™ Series distributed network-based video products.
- One year (except video heads) on video cassette recorders (VCRs). Video heads will be covered for a period of six months.
- Six months on all pan and tilts, scanners or preset lenses used in continuous motion applications (that is, preset scan, tour and auto scan modes).

Pelco will warrant all replacement parts and repairs for 90 days from the date of Pelco shipment. All goods requiring warranty repair shall be sent freight prepaid to Pelco, Clovis, California. Repairs made necessary by reason of misuse, alteration, normal wear, or accident are not covered under this warranty.

Pelco assumes no risk and shall be subject to no liability for damages or loss resulting from the specific use or application made of the Products. Pelco's liability for any claim, whether based on breach of contract, negligence, infringement of any rights of any party or product liability, relating to the Products shall not exceed the price paid by the Dealer to Pelco for such Products. In no event will Pelco be liable for any special, incidental or consequential damages (including loss of use, loss of profit and claims of third parties) however caused, whether by the negligence of Pelco or otherwise.

The above warranty provides the Dealer with specific legal rights. The Dealer may also have additional rights, which are subject to variation from state to state.

If a warranty repair is required, the Dealer must contact Pelco at (800) 289-9100 or (559) 292-1981 to obtain a Repair Authorization number (RA), and provide the following information:

1. Model and serial number
2. Date of shipment, P.O. number, Sales Order number, or Pelco invoice number
3. Details of the defect or problem

If there is a dispute regarding the warranty of a product which does not fall under the warranty conditions stated above, please include a written explanation with the product when returned.

Method of return shipment shall be the same or equal to the method by which the item was received by Pelco.

### RETURNS

In order to expedite parts returned to the factory for repair or credit, please call the factory at (800) 289-9100 or (559) 292-1981 to obtain an authorization number (CA number if returned for credit, and RA number if returned for repair).

All merchandise returned for credit may be subject to a 20% restocking and refurbishing charge.

Goods returned for repair or credit should be clearly identified with the assigned CA or RA number and freight should be prepaid. Ship to the appropriate address below.

*If you are located within the continental U.S., Alaska, Hawaii or Puerto Rico, send goods to:*

Service Department  
Pelco  
3500 Pelco Way  
Clovis, CA 93612-5699

*If you are located outside the continental U.S., Alaska, Hawaii or Puerto Rico and are instructed to return goods to the USA, you may do one of the following:*

If the goods are to be sent by a COURIER SERVICE, send the goods to:

Pelco  
3500 Pelco Way  
Clovis, CA 93612-5699 USA

If the goods are to be sent by a FREIGHT FORWARDER, send the goods to:

Pelco c/o Expeditors  
473 Eccles Avenue  
South San Francisco, CA 94080 USA  
Phone: 650-737-1700  
Fax: 650-737-0933



This equipment contains electrical or electronic components that must be recycled properly to comply with Directive 2002/96/EC of the European Union regarding the disposal of waste electrical and electronic equipment (WEEE). Contact your local dealer for procedures for recycling this equipment.

### REVISION HISTORY

Manual #	Date	Comments
C1959M	6/99	Original version.

Pelco, the Pelco logo, Camclosure, Esprit, Genex, Legacy, and Spectra are registered trademarks of Pelco. Endura and ExSite are trademarks of Pelco.

©Copyright 1999, Pelco.  
All rights reserved.



## Free Manuals Download Website

<http://myh66.com>

<http://usermanuals.us>

<http://www.somanuals.com>

<http://www.4manuals.cc>

<http://www.manual-lib.com>

<http://www.404manual.com>

<http://www.luxmanual.com>

<http://aubethermostatmanual.com>

Golf course search by state

<http://golfingnear.com>

Email search by domain

<http://emailbydomain.com>

Auto manuals search

<http://auto.somanuals.com>

TV manuals search

<http://tv.somanuals.com>