



PSKIT8100

# Pressure Sensor Option

For EH8100 Series  
Pressurized Camera Enclosure

C1445M-D (11/04)



# Contents

---

Important Safeguards and Warnings .....	5
Description .....	5
Installation .....	6
Enclosure Disassembly .....	6
Pressure Sensor Installation .....	7
Enclosure Reassembly and Recharging .....	9
Reassembly .....	9
Recharging .....	9
Power Connection .....	9

## List of Illustrations

1	EH8100 Series Enclosure - Rear View .....	6
2	EH8100 Series Enclosure - Rear Plate, Inside View .....	7
3	EH8100 Series Enclosure - Wiring Diagram .....	8



# Important Safeguards and Warnings

---

1. Read these instructions.
2. Keep these instructions.
3. Heed all warnings.
4. Follow all instructions.
5. Refer all servicing to qualified service personnel. Servicing is required when the apparatus has been damaged in any way, such as power-supply cord or plug is damaged, liquid has been spilled or objects have fallen into the apparatus, the apparatus has been exposed to rain or moisture, does not operate normally, or has been dropped.
6. Unless the unit is specifically marked as a NEMA Type 3, 3R, 3S, 4, 4X, 6, or 6P enclosure, it is designed for indoor use only and it must not be installed where exposed to rain and moisture.
7. Only use replacement parts recommended by Pelco.
8. After replacement/repair of this unit's electrical components, conduct a resistance measurement between the line and exposed parts to verify the exposed parts have not been connected to the line circuitry.

## Description

The PSKIT8100 Pressure Sensor is designed for use with the EH8100 Series Enclosure. The sensor ensures that enclosure pressure stays at an acceptable operation level. The PSKIT8100 provides contact closure when the internal pressure of the enclosure falls below the required 5 psi.

# Installation

## ENCLOSURE DISASSEMBLY

1. Disconnect power to the enclosure.
2. Remove the ground wire from the ground stud on the back of the enclosure.
3. Remove the electrical connector from the rear of the enclosure by turning the outer ring counterclockwise and pulling the mating portion of the connector off.
4. You may remove the enclosure from its mount to make the installation process easier.
5. Remove the cap from the Schraeder valve (refer to Figure 1).
6. Relieve internal enclosure pressure by depressing the center stem of the Schraeder valve.

**⚠ CAUTION:** Pressure must be released prior to opening the enclosure or personal injury may result.

7. Remove the rear plate of the enclosure (refer to Figure 1) and do the following:
  - a. Use a screwdriver to pry the end of the spiral retaining ring from the retaining ring groove.
  - b. Pull on the "T" handle to remove the rear plate from the housing.

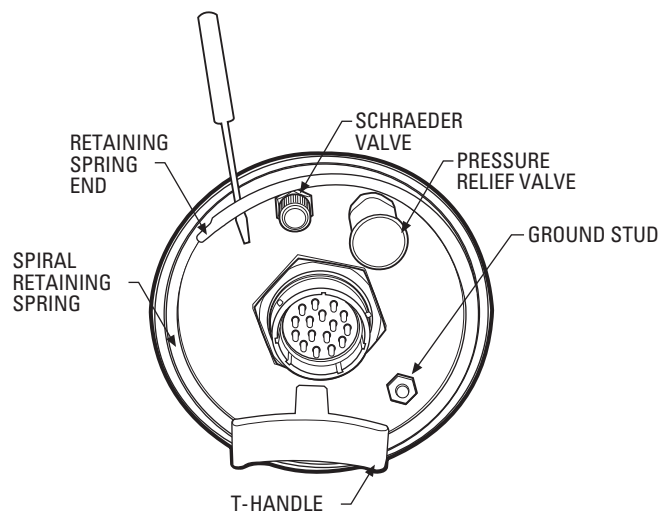
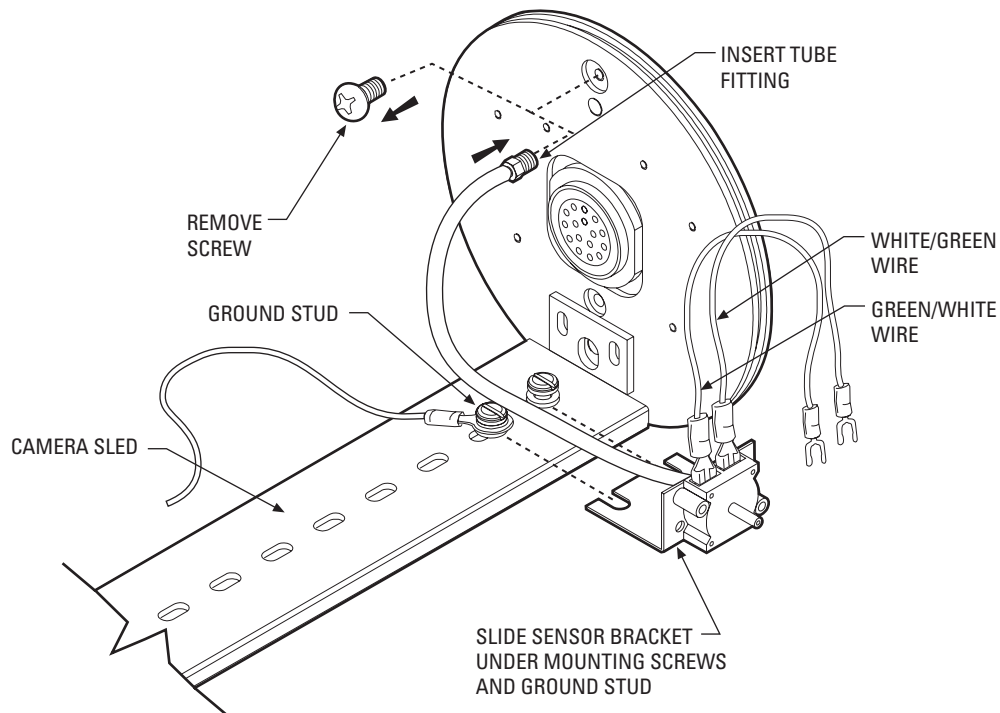

**Figure 1.** EH8100 Series Enclosure - Rear View

# Pressure Sensor Installation

To install the pressure sensor, perform the following steps.

1. Remove the screw located inside the top portion of the enclosure's rear plate (refer to Figure 2). Insert the pressure sensor tube fitting in the hole.
2. Loosen the camera sled mounting screws (refer to Figure 2). Slide the sensor bracket under the mounting screws and ground lug. Tighten the screws.
3. Connect the wire leads (refer to Figure 2 and Figure 3):
  - a. Green/white wire - Insert the push-on lug into the connector on the pressure sensor assembly. Connect the spade lug to the power terminal block under the AC NEUT wire.
  - b. White/green wire - Insert the push-on lug into the connector on the pressure sensor assembly. Connect the spade lug to the power terminal block above the AC LINE wire.



**Figure 2.** EH8100 Series Enclosure - Rear Plate, Inside View

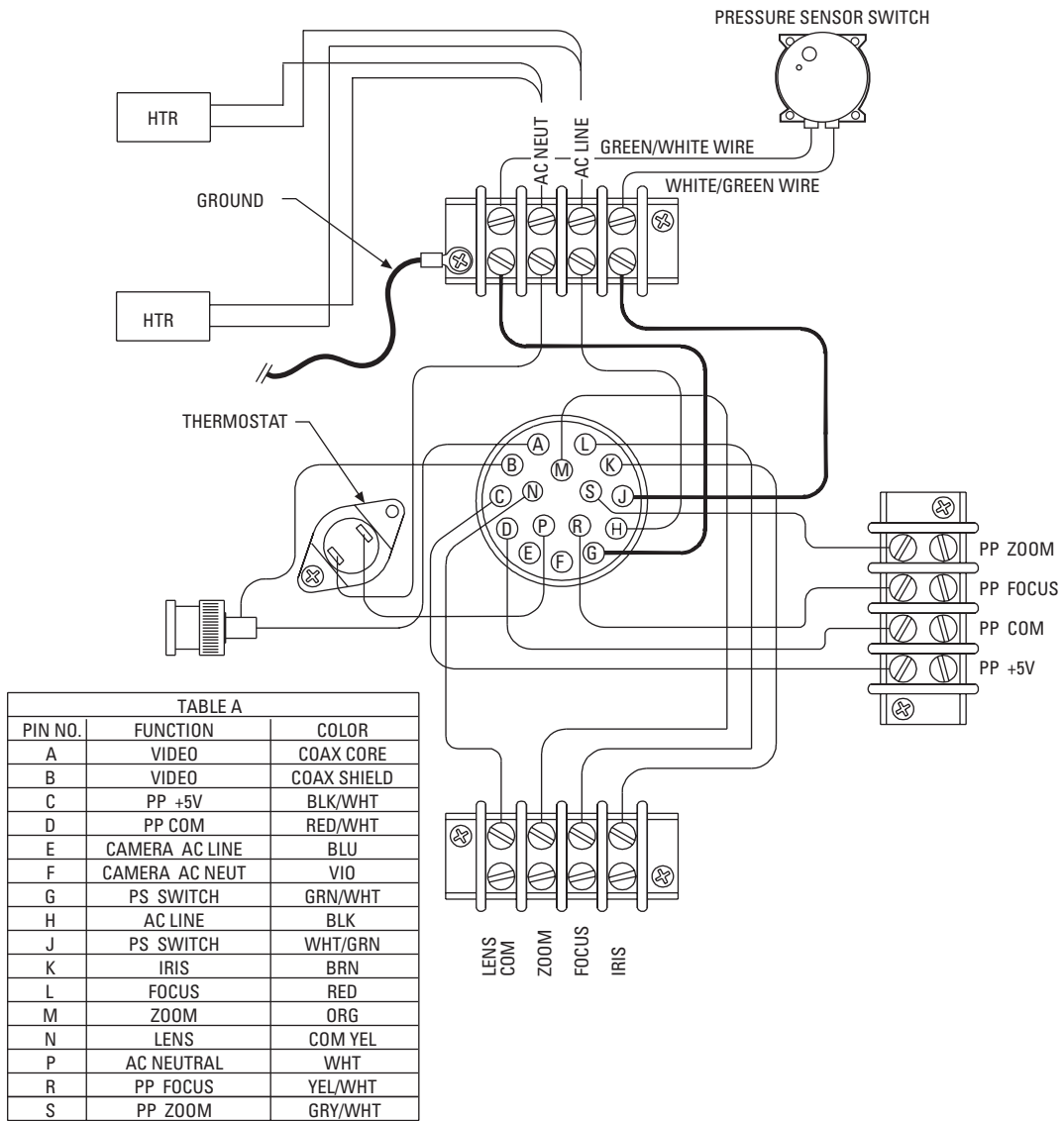

Figure 3. EH8100 Series Enclosure - Wiring Diagram



# Enclosure Reassembly and Recharging

---

## REASSEMBLY

Whenever the enclosure is disassembled, it should be recharged after reassembly and prior to installation. Recharging requires the use of a Pelco EH8000RKIT recharge kit (or equivalent) and applicable O-ring kit, part EH8004ORKIT or EH8006ORKIT.

To prepare the enclosure for recharging, follow the steps below.

1. Once the enclosure has been disassembled, remove the O-ring from the rear plate and install a new O-ring in the O-ring groove.
2. After installing the new O-ring, smear a liberal amount of O-ring lubricant (provided) on the exterior surface of the O-ring and rear plate. Replace the desiccant bag in the enclosure with the new one (provided).
3. Slide the camera sled back into the body making sure the front lip of the sled is under the retaining bracket of the enclosure. When fully installed, the rear plate will fit firmly into the rear opening of the housing and the retaining groove will be fully visible.
4. Reinstall the spiral retaining ring in the groove in the rear of the enclosure.

## RECHARGING

1. Pressurize the inside of the enclosure using the EH8000RKIT recharge kit. Connect the regulator to the tank by threading the nut into the socket of the tank valve. Tighten with a wrench. This regulator is factory preset for 12 psi (83 kPa).
2. Once the regulator has been secured to the tank, open the regulator valve first and then the tank valve.
3. Remove the Schraeder valve cap (refer to Figure 1). Affix the self-holding tire chuck to the Schraeder valve.
4. To reduce the purge time necessary to remove oxygen from the enclosure, position it so that the window is pointing up.
5. Remove the plastic cap on the pressure relief valve on the rear of the enclosure. Use a small screwdriver and hold the valve open. Allow the nitrogen to flow through the enclosure until the humidity indicator registers the lowest humidity level, changing color from pink to blue. (The humidity indicator can be viewed through the front window of the enclosure looking at the inside top of the enclosure.) Once the humidity indicator registers the lowest level, remove the screwdriver and allow nitrogen to continue to flow into the enclosure until you no longer hear the flow of nitrogen from the tank to the enclosure.
6. Remove the tire chuck from the Schraeder valve. Replace the Schraeder valve and pressure relief valve caps.

## POWER CONNECTION

1. Reconnect the ground wire to the ground stud on the back of the enclosure.
2. Reconnect the electrical connector and turn on power.



## PRODUCT WARRANTY AND RETURN INFORMATION

### WARRANTY

Pelco will repair or replace, without charge, any merchandise proved defective in material or workmanship **for a period of one year** after the date of shipment.

Exceptions to this warranty are as noted below:

- Five years on FT/FR8000 Series fiber optic products and the following fixed camera models: CC3701H-2, CC3701H-2X, CC3751H-2, CC3651H-2X, MC3651H-2, and CC3651H-2X.
- Three years on all other fixed camera models (including Camclosure® Integrated Camera Systems) and Genex® Series (multiplexers, server, and keyboard).
- Two years on all standard motorized or fixed focal length lenses.
- Two years on Legacy®, CM6700/CM6800/CM8500/CM9500/CM9700 Series Matrix, DF5 and DF8 Series Fixed Dome products.
- Two years on Spectra®, Esprit®, and PS20 Scanners, including when used in continuous motion applications.
- Two years on Esprit® and WW5700 Series window wiper (excluding wiper blades).
- Eighteen months on DX Series digital video recorders and NVR300 Series network video recorders.
- One year (except video heads) on video cassette recorders (VCRs). Video heads will be covered for a period of six months.
- Six months on all pan and tilts, scanners or preset lenses used in continuous motion applications (that is, preset scan, tour and auto scan modes).

Pelco will warrant all replacement parts and repairs for 90 days from the date of Pelco shipment. All goods requiring warranty repair shall be sent freight prepaid to Pelco, Clovis, California. Repairs made necessary by reason of misuse, alteration, normal wear, or accident are not covered under this warranty.

Pelco assumes no risk and shall be subject to no liability for damages or loss resulting from the specific use or application made of the Products. Pelco's liability for any claim, whether based on breach of contract, negligence, infringement of any rights of any party or product liability, relating to the Products shall not exceed the price paid by the Dealer to Pelco for such Products. In no event will Pelco be liable for any special, incidental or consequential damages (including loss of use, loss of profit and claims of third parties) however caused, whether by the negligence of Pelco or otherwise.

The above warranty provides the Dealer with specific legal rights. The Dealer may also have additional rights, which are subject to variation from state to state.

If a warranty repair is required, the Dealer must contact Pelco at (800) 289-9100 or (559) 292-1981 to obtain a Repair Authorization number (RA), and provide the following information:

1. Model and serial number
2. Date of shipment, P.O. number, Sales Order number, or Pelco invoice number
3. Details of the defect or problem

If there is a dispute regarding the warranty of a product which does not fall under the warranty conditions stated above, please include a written explanation with the product when returned.

Method of return shipment shall be the same or equal to the method by which the item was received by Pelco.

### RETURNS

In order to expedite parts returned to the factory for repair or credit, please call the factory at (800) 289-9100 or (559) 292-1981 to obtain an authorization number (CA number if returned for credit, and RA number if returned for repair).

All merchandise returned for credit may be subject to a 20% restocking and refurbishing charge.

Goods returned for repair or credit should be clearly identified with the assigned CA or RA number and freight should be prepaid. Ship to the appropriate address below.

*If you are located within the continental U.S., Alaska, Hawaii or Puerto Rico, send goods to:*

Service Department  
Pelco  
3500 Pelco Way  
Clovis, CA 93612-5699

*If you are located outside the continental U.S., Alaska, Hawaii or Puerto Rico and are instructed to return goods to the USA, you may do one of the following:*

If the goods are to be sent by a COURIER SERVICE, send the goods to:

Pelco  
3500 Pelco Way  
Clovis, CA 93612-5699 USA

If the goods are to be sent by a FREIGHT FORWARDER, send the goods to:

Pelco c/o Expeditors  
473 Eccles Avenue  
South San Francisco, CA 94080 USA  
Phone: 650-737-1700  
Fax: 650-737-0933

### REVISION HISTORY

Manual #	Date	Comments
C1445M	12/95	Original version.
C1445M-A	5/96	Updated to include corrections to reference callouts in Section 3.4. Updated Figure 3. All changes in response to ECO# 95-220 and 96-131.
C1445M-B	5/96	Revised to include updated Figures 2 and 4.
C1445M-C	8/00	Revised installation instructions and wiring diagram layout. Updated manual to new format.
C1445M-D	11/04	Factory preset for regulator changed to 12 psi per ECO#04-9807. Updated Important Safety Instructions, Warranty and layout.



Worldwide Headquarters  
3500 Pelco Way  
Clovis, California 93612 USA

USA & Canada  
Tel: 800/289-9100  
Fax: 800/289-9150

International  
Tel: 1-559/292-1981  
Fax: 1-559/348-1120

**[www.pelco.com](http://www.pelco.com)**

**ISO9001**

United States | Canada | United Kingdom | The Netherlands | Singapore | Spain | Scandinavia | France | Middle East

## Free Manuals Download Website

<http://myh66.com>

<http://usermanuals.us>

<http://www.somanuals.com>

<http://www.4manuals.cc>

<http://www.manual-lib.com>

<http://www.404manual.com>

<http://www.luxmanual.com>

<http://aubethermostatmanual.com>

Golf course search by state

<http://golfingnear.com>

Email search by domain

<http://emailbydomain.com>

Auto manuals search

<http://auto.somanuals.com>

TV manuals search

<http://tv.somanuals.com>