



**CM9760-CXTA  
Coaxitron® Translator**

**Installation/  
Operation Manual**

**C539M-A (12/01)**

Pelco • 3500 Pelco Way • Clovis, CA 93612-5699 USA • [www.pelco.com](http://www.pelco.com)  
In North America and Canada: Tel (800) 289-9100 • FAX (800) 289-9150  
International Customers: Tel +1(559) 292-1981 • FAX +1(559) 348-1120

# CONTENTS

<b>SECTION I: CXTA OVERVIEW</b>	
1.1 DESCRIPTION .....	6
1.2 MODELS .....	6
1.3 CONTROL AND RECEIVER OPTION COMPATIBILITY .....	6
<b>SECTION II: CXTA DEFINING CHARACTERISTICS</b>	
2.1 CONFIGURATION AND CONNECTIONS–CXTA .....	7
2.1.1 POWER .....	7
2.1.2 COMMUNICATIONS .....	7
2.1.3 BNCs .....	8
2.1.4 CONFIGURATION SWITCH .....	9
2.1.4.1 BNC Input Grouping (Receiver Side) .....	9
2.1.4.2 Protocol Type .....	10
2.1.4.3 Unused DIP Switch .....	10
2.1.4.4 BAUD Rates .....	10
2.1.4.5 Channel or Address Select .....	11
2.1.4.6 Equipment Type .....	11
<b>SECTION III: CXTA INSTALLATION</b>	
3.1 MOUNTING THE CXTA .....	12
3.2 INSTALLATION CONFIGURATIONS .....	12
3.2.1 DIRECT MODE (P Protocol) .....	12
3.2.2 9760 SYSTEM HOOKUP (P Protocol) .....	13
3.2.3 DX7000 CONTROLLER HOOKUP (D Protocol) .....	13
3.2.4 MPT9500 CONTROLLER HOOKUP (D Protocol) .....	13
3.3 SOFTWARE CONSIDERATIONS .....	19
3.3.1 9760 SYSTEM .....	19
3.3.2 CM9760-KBD DIRECT MODE .....	20
3.3.3 MPT9500 TRANSMITTER/CONTROLLER .....	20
3.3.4 DX7000 DIGITAL VIDEO RECORDER .....	20
<b>SECTION IV: CXTA OPERATION</b>	
4.1 POWER-UP .....	21
4.2 COMMAND SET .....	21
4.3 COMMAND SET VARIATION .....	21
<b>SECTION V: APPENDIX</b>	
5.1 COMMUNICATION PARAMETERS .....	22
5.2 CABLE PARAMETERS .....	24
<b>SECTION VI: GENERAL</b>	
6.1 SPECIFICATIONS .....	27
6.2 REGULATORY NOTICES .....	28

## LIST OF ILLUSTRATIONS

<b>Figure</b>	<b>Page</b>
1 Equipment Control and Configuration Options .....	6
2 CM9760-CXTA Rear View .....	7
3 Fuse Replacement .....	7
4 Cascading .....	8
5 Configuration Switch .....	9
6 BNC Input Group and Protocol "Flavor" .....	9
7 Protocol Type .....	10
8 Unused Configuration Bit .....	10
9 Baud Rate Settings .....	10
10 Channel or Address Select .....	11
11 Equipment Type .....	11
12 Rack Mounting for the CM9760-CXTA .....	12
13 Direct Mode Installation .....	15
14 9760 System Installation .....	16
15 DX7000 Installation .....	17
16 MPT9500 Installation .....	18
17 COMMS File Example for the CXTA .....	19
18 CAMERA Files Example for the CXTA .....	20
19 Cable Identification .....	23
20 Data Rate vs. Cable Length .....	24
21 Remote Wiring a CM9760-KBD .....	25

## LIST OF TABLES

<b>Table</b>	<b>Page</b>
A Connection Disparities .....	7
B Signal Interface Table .....	22
C (TIA/EIA-422) Cable Example .....	26

## LIST OF FLOWCHARTS

<b>Chart</b>	<b>Page</b>
1 Installation Decision Tree .....	14

(This page intentionally left blank.)

## IMPORTANT SAFEGUARDS AND WARNINGS

Prior to installation and use of this product, the following WARNINGS should be observed.

1. Installation and servicing should only be done by qualified service personnel and conform to all local codes.
2. Unless the unit is specifically marked as a NEMA Type 3, 3R, 3S, 4, 4X, 6 or 6P enclosure, it is designed for indoor use only and it must not be installed where exposed to rain and moisture.
3. Only use replacement parts recommended by Pelco.
4. After replacement/repair of this unit's electrical components, conduct a resistance measurement between line and exposed parts to verify the exposed parts have not been connected to line circuitry.
5. If the unit has fuses, replace fuses only with the same type fuses for continued protection against risk of fire.

The product and/or manual may bear the following marks:



This symbol indicates that dangerous voltage constituting a risk of electric shock is present within this unit.



This symbol indicates that there are important operating and maintenance instructions in the literature accompanying this unit.

<b>CAUTION:</b>
RISK OF ELECTRIC SHOCK. DO NOT OPEN.

Please thoroughly familiarize yourself with the information in this manual prior to installation and operation.

9760-CXTA COM PARAMETERS	
<b>CC1 to CXTA Interface:</b>	
(Comm Parameters)	
Equipment #	9
Baud Rate	4800
Parity	EVEN
Stop	1
Word	8

**NOTE:** For those familiar with device attachment to 9760 systems, a convenient reference box is provided in the margin that lists the COMMS communication file parameters for CXTA attachment to a CM9760-CC1. Refer to Section 3.3 Software Considerations, for additional information.

## SECTION I: CXTA OVERVIEW

### 1.1 DESCRIPTION

The CM9760-CXTA (Coaxitron® translator) is a peripheral product of the CM9760 family of Pelco matrix switches. The previous CXT model interfaced Coaxitron capable receivers with the 9760 System (P Protocol). The current CXTA unit still supports that function. In addition, it can be used to interface appropriately configured systems that utilize D protocol for PTZ control. This allows the CXTA to be used with the DX7000 (Digital Video Recorder) and the MPT9500 (Transmitter/Controller), as well as the CM9760 system, if desired.

The CM9760-CXTA (Coaxitron translator) obsoletes and replaces previous models of the Coaxitron translator.

### 1.2 MODELS

CM9760-CXTA Indoor rack-mount model, one RU high. (CE)

### 1.3 CONTROL AND RECEIVER OPTION COMPATIBILITY

The current mix of controller and receiver “types” that the CM9760-CXTA can interface is illustrated in Figure 1 below. On the receiver side, note that Intercept™ and Spectra® occur in the same box separated by an “OR” statement. The “OR” conjunction refers to constraints associated with the use of these two receivers on the same translator. The rules addressing these limitations are discussed in the *BNC Input Grouping* and the *Equipment Type* subsections in the *Configuration Switch* portion of section 2.1 *Configuration and Connections – CXTA*.

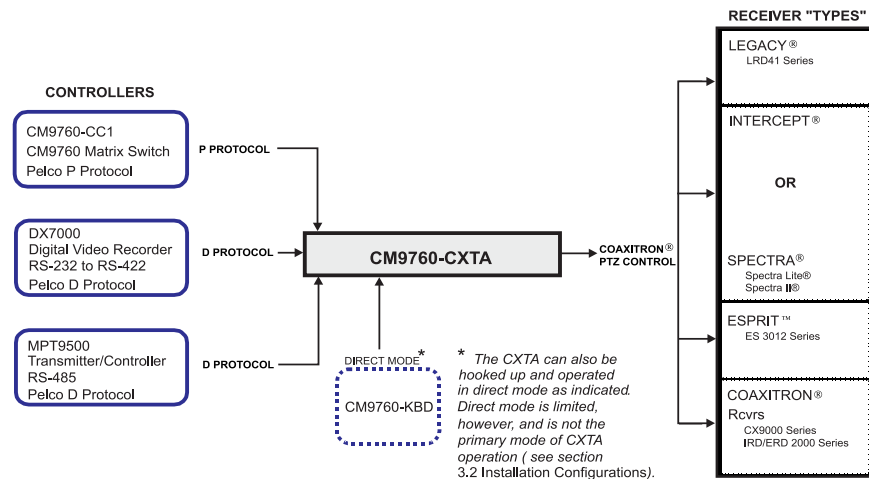

## SECTION II: CXTA DEFINING CHARACTERISTICS

A number of configuration and connection decisions are made at the CXTA level in order to interface it with one of three controllers, one of two protocol "flavors" and a large selection of receiver options. The next section lists connection and configuration options determined at the CXTA level. For this purpose, the rear view of the CXTA is illustrated in Figure 2.

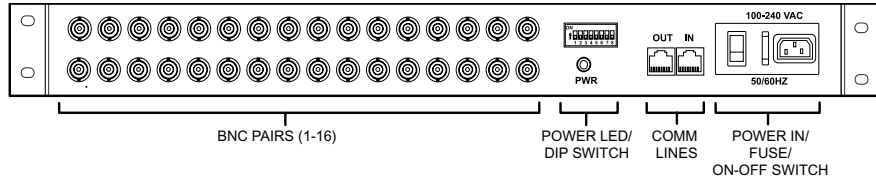

Figure 2. CM9760-CXTA Rear View

### 2.1 CONFIGURATION AND CONNECTIONS-CXTA

#### 2.1.1 POWER

The CM9760-CXTA utilizes a 100V/240V @ 50/60Hz auto-ranging power supply. The external cord connection, power switch and fuse are located on the right side of the unit when viewed from the rear of the unit. For fuse replacement, refer to Figure 3. A power cord and Euro-plug adapter are supplied with the unit.

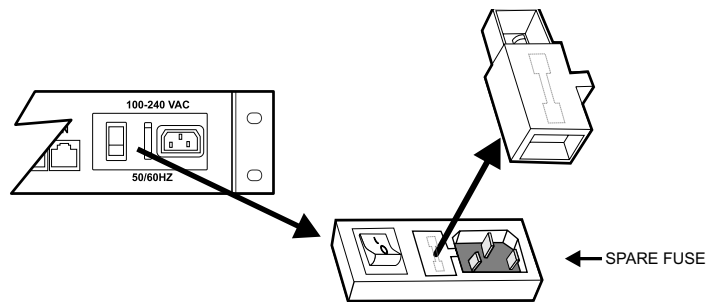

Figure 3. Fuse Replacement

#### 2.1.2 COMMUNICATIONS

The 8-pin, RJ-45 communication input connector located on the rear of the CXTA, and labeled IN, is the data connection to which all controllers must interface. This presents immediate disparities with respect to source (controller) and destination (CXTA) connections that are spelled out in Table A below:

Table A. Connection Disparities

CONTROLLER	SOURCE CONNECTION/ PROTOCOL FLAVOR	DESTINATION (CXTA INPUT)
CM9760-CC1	RJ-45, 8-PIN, RS-422/ P Protocol	RJ-45, 8-PIN, RS-422, P or D Protocol
MPT9500	RJ-12, 6-PIN, RS-485/ D Protocol	
DX7000	DB9, RS-232/ D Protocol	

In section 3.2 *Installation Configurations*, questions related to controller/translator connectivity are answered by means of controller-specific illustrations.

The 8-pin, RJ-45 communication output connector labeled OUT is located next to the input connector and is used to connect, daisy-chain or cascade two CXTA units together, resulting in 32 ports addressable from one controller port. Not all controllers, however, can utilize cascading and/or are capable of addressing 32 ports.

The breakdown, with respect to cascading for each controller, is as follows:

- For the 9760, cascading is allowed; addressing is no problem.
- For the MPT9500, addressing 32 receivers is no problem; it is not, however very practical as the controller itself is Coaxitron capable. See the remarks made in the *MPT Controller Hookup* portion of section 3.2 *Installation Configurations*.
- For the DX7000, only 16 receivers at a time are addressable, therefore it can handle only one attached CXTA unit. This constraint is also necessary because the DX7000 can interface only 16 loop back video inputs.

The data cable that runs between the labeled IN connector on the CXTA and the RJ-45 Sercom port connection located on the rear of the 9760 matrix controller (CM9760-CC1) is provided. This is a reverse, 8-pin, flat cable (see Figure 4). Since this is the most often encountered configuration, the cable is provided.

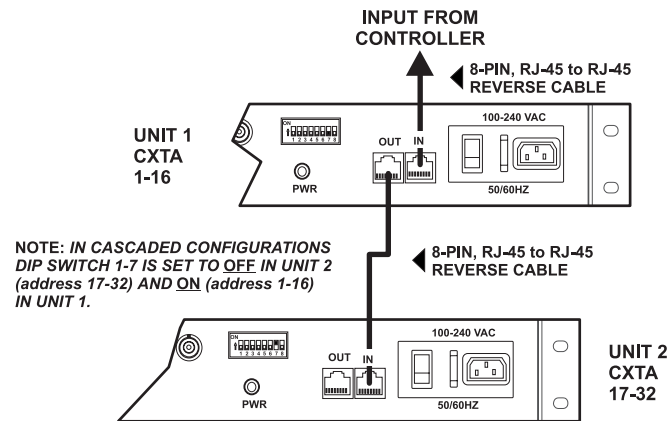

**Figure 4.** Cascading

The provided data cable cannot be used (as is, out of the box) with the DX7000 or the MPT9500. Each of these has different cabling requirements that are illustrated in the corresponding installation examples (see Figures 15 and 16, respectively).

### 2.1.3 BNCs

There are 16 pairs (32 total) of BNCs on each unit (see Figure 2). These are IN-OUT, to-from, dual-function BNCs. The top or bottom row can be used as INPUTS or OUTPUTS. If the top row of BNCs are used as OUTPUTS, the corresponding BNCs on the bottom row are used as INPUTS, and vice versa. Characteristics and functions of BNC use are as follows:

- The BNCs are used for video input/output, command/control and in/out looping.
- Receiver access (by controllers) must correspond to the numbered BNC INPUT connector to which the receiver is attached.
- The BNCs are numbered and addressed, left to right, 1-16. The BNCs on a cascaded translator (the second unit) are addressed and numbered, left to right, 17-32. The address response for each controller is set via DIP 1-7 (see Figure 10).



## 2.1.4 CONFIGURATION SWITCH

The decode of configuration switch functions is indicated in Figure 5 and discussed in detail in the paragraphs that follow.

This configuration switch configures the translator with respect to the following functions:

1. BNC Input Group (allocated in x8 groupings) and protocol "flavor" (15 or 32 bit Coaxitron)
2. Choice of P or D protocol.
3. Communications channel baud rate (under P protocol only).
4. Cascade addressing (16/32 channel or translator address range)
5. Type of 32-bit protocol (Intercept or Spectra).

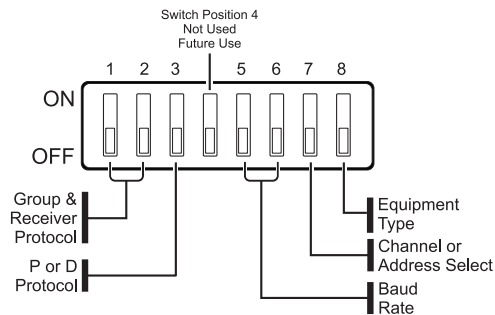

Figure 5. Configuration Switch

**NOTE:** Configuration switch positions are read only at power-up time; therefore, switch changes made after power is applied have no effect until power is recycled.

### 2.1.4.1 BNC Input Grouping (Receiver Side)

The sixteen BNCs to which Coaxitron receivers are attached are split into x8 groups (1-8 and 9-16). Each group is further defined as entertaining one of two protocol "flavors": 15- or 32-bit (these are references to 15-bit standard Coaxitron or 32-bit extended Coaxitron, respectively). Therefore, a combination of 15- and 32-bit protocol "flavors" on the same unit is possible. Conversely, if both x8 groups on the same translator are assigned the same protocol flavor, then the entire translator interfaces only 15-bit or only 32-bit Coaxitron receivers.

**IMPORTANT:** If any x8 group combination is set to 32-bit, DIP switch 1-8 must be set to restrict equipment use for the entire translator to ONLY one equipment type (receiver): Intercept or Spectra.

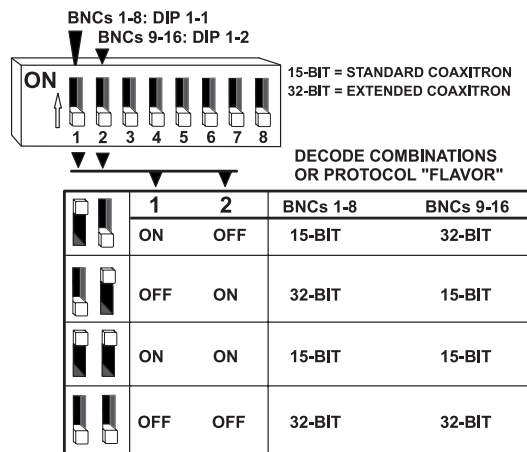

Figure 6. BNC Input Group and Protocol "Flavor"

**NOTE:** When protocol is set for D (DIP 1-3 ON), then the existing baud rate settings (DIP 1-5 and 1-6) for the configuration switch are ignored. D protocol operates independent of baud rate setting and automatically reverts to a fixed baud rate of 2400 (8-bit, no parity, 1 stop).

### 2.1.4.2 Protocol Type

This bit is set to correspond to the protocol input of the associated controller (see Figure 7).

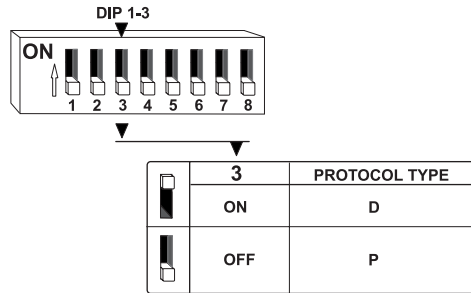

Figure 7. Protocol Type

### 2.1.4.3 Unused DIP Switch

DIP switch position 1-4 is not used but is reserved for future use.

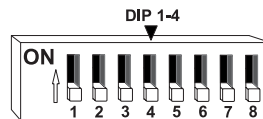

Figure 8. Unused Configuration Bit

### 2.1.4.4 BAUD Rates

The baud rate chosen must correspond to the the communicaiton baud rate of the controler to which the CXTA is attached.

Note, as Figure 9 states, that these settings apply to attached P protocol controllers. The translator reverts to a fixed baud rate of 2400 if a D type controller is interfaced. The baud rate settings of DIP 1-5 and 1-6 are ignored.

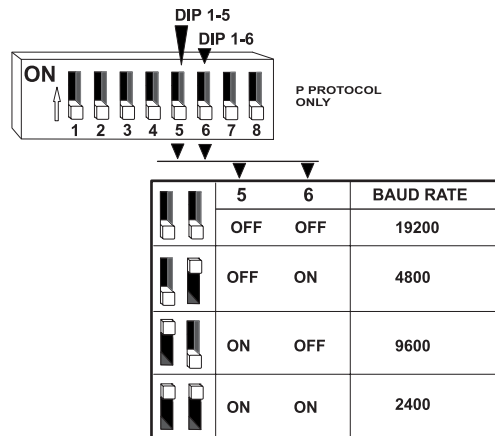

Figure 9. Baud Rate Settings

### 2.1.4.5 Channel or Address Select

If DIP 1-7 is set to the OFF position, the translator responds to addresses 1-16. If DIP 1-7 is ON, the translator responds to addresses 17-32. Therefore, in a cascaded configuration, DIP 1-7 on the first translator would normally be set to OFF (for the first 16 addresses) and DIP 1-7 on the second translator would be set to ON for the second set of 16 addresses (17-32). The important thing is that DIP 1-7 on both translators in a cascaded configuration are not set the same (both ON or both OFF).

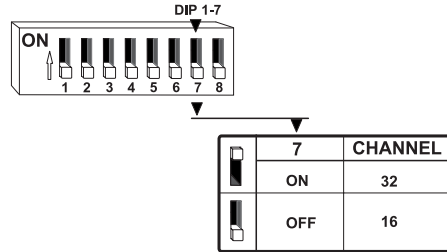

Figure 10. Channel or Address Select

### 2.1.4.6 Equipment Type

The setting of this DIP switch position is relevant only if DIP 1-1 or 1-2 is set for 32-bit Coaxitron on any x8 grouping on a translator. If the 32-bit setting is chosen on any x8 grouping, then DIP 1-8 excludes the use of both Intercept and Spectra receivers on the same translator at the same time. You must make a choice between using one equipment type or the other for the translator in question.

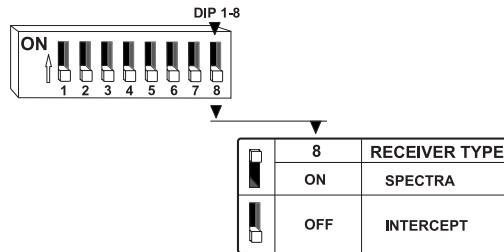

Figure 11. Equipment Type

## SECTION III: CXTA INSTALLATION

### 3.1 MOUNTING THE CXTA

Installation of the CM9760-CXTA translator is relatively simple (refer to Figure 12). It is rack mountable in a standard 19-inch (48.26 cm) rack, using only one RU of vertical rack space. Once the unit is physically mounted, cable hookup in accordance with the configuration being interfaced, is the next item on the installation list.

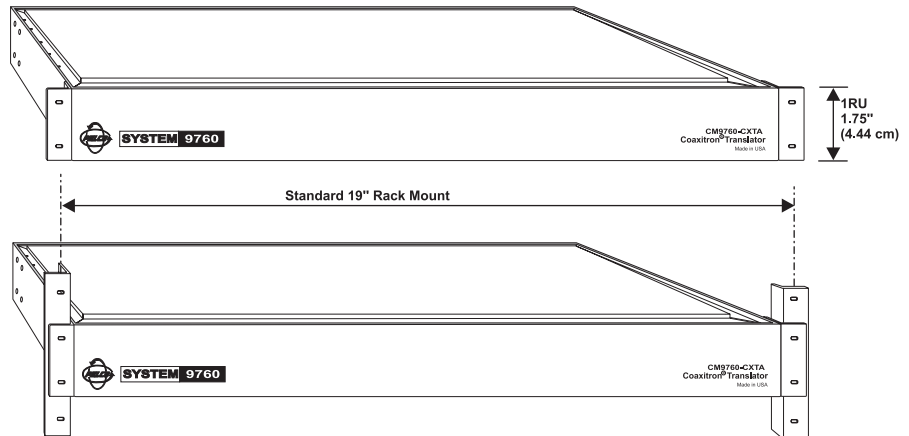

Figure 12. Rack Mounting for the CM9760-CXTA

### 3.2 INSTALLATION CONFIGURATIONS

The number of installation configurations that can be entertained using the CXTA depends on the controller types available (there are three main types) and on the configuration capabilities of the CXTA itself. We must also mention a fourth type that uses the CM9760-KBDs capabilities for direct mode operation as a controller for CXTA use independent of its normal association with the 9760 System. We therefore consider the following installation configurations:

#### 3.2.1 DIRECT MODE (P Protocol)

In direct mode, two possibilities are:

1. A single translator hooked up in direct mode, or
2. Two translators hooked up in direct mode; the first connected to COM1 and the second connected to COM 2 of the keyboard.

The second possibility (item 2) encompasses the first, so an installation illustrating it is shown in Figure 13.

**NOTE:** You cannot cascade translators off a COM port on a CM9760-KBD when using direct mode operation because only 16 receivers can be interfaced at a time on any one COM port of the KBD; however, you can connect one translator by paralleling off COM 1 of the KBD by utilizing the empty RJ-45 out connector on the Universal Power Supply (UPS) used with the KBD and, at the same time, connect another translator to COM 2 of the KBD to support a total of 32 Coaxitron ports.

**NOTE:** When running the translator from ports hooked to a CM9760 System (system mode), configure the communication parameters of the CM9760 on that port for "even" parity or the translator will not work. Direct mode (see previous configuration) is not a concern since the CM9760-KBD is configured by default for even parity.

### **3.2.2 9760 SYSTEM HOOKUP (P Protocol)**

Two possibilities are:

1. Single or multiple translators hooked to unique Sercom ports on a system matrix switch, or
2. Item (1) with the addition of cascaded translators added to the mix.

The second possibility (item 2) encompasses the first, so a system hookup illustrating it is shown in Figure 14.

### **3.2.3 DX7000 CONTROLLER HOOKUP (D Protocol)**

Only one possibility is available for DX7000 control of the CXTA. That configuration, along with hookup details, is shown in Figure 15. Note the viewing advantage in that one to sixteen interfaced receiver inputs can be viewed at the same time on the system monitor. Moreover, views can also be captured and recorded.

### **3.2.4 MPT9500 CONTROLLER HOOKUP (D Protocol)**

Since the MPT9500 can be configured for D protocol, it can be used to control the CXTA. This is not an advantage with respect to direct control of Coaxitron receivers (the MPT9500 is Coaxitron capable); however, there are two viable possibilities:

1. If you want to combine control of existing D protocol equipment with Coax control of CXTA connected receivers on the same data line
2. If you want to control and view more than one Coaxitron receiver at a time without the necessity of an intervening manual switcher.

An illustration of item two is shown in Figure 16.

The following flowchart might prove helpful as an aide in configuring the different systems mentioned above with CXTA translator(s). The flowchart does not include direct mode using the CM9760-KBD.

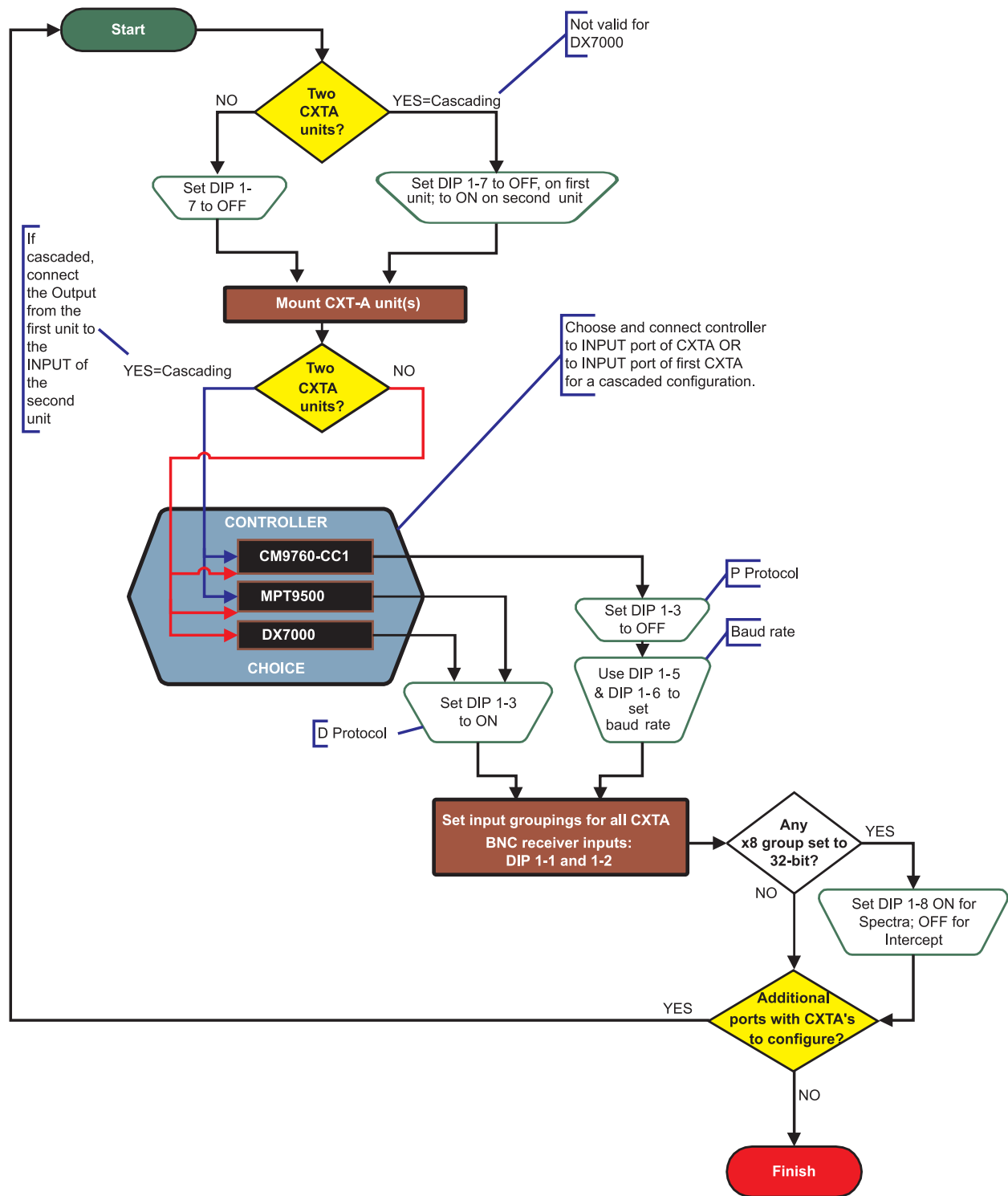

Flowchart 1. Installation Decision Tree

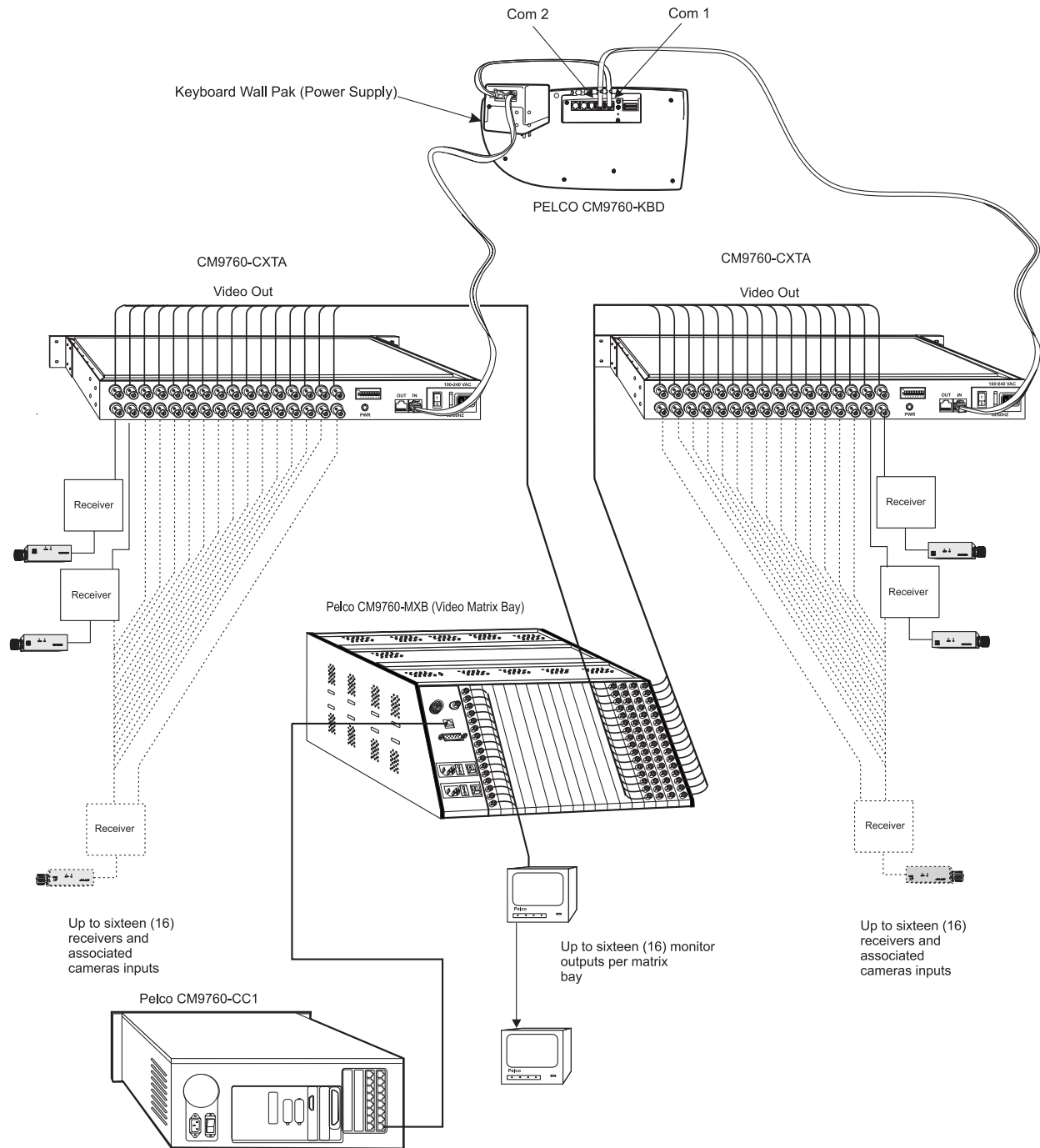

**Figure 13. Direct Mode Installation**

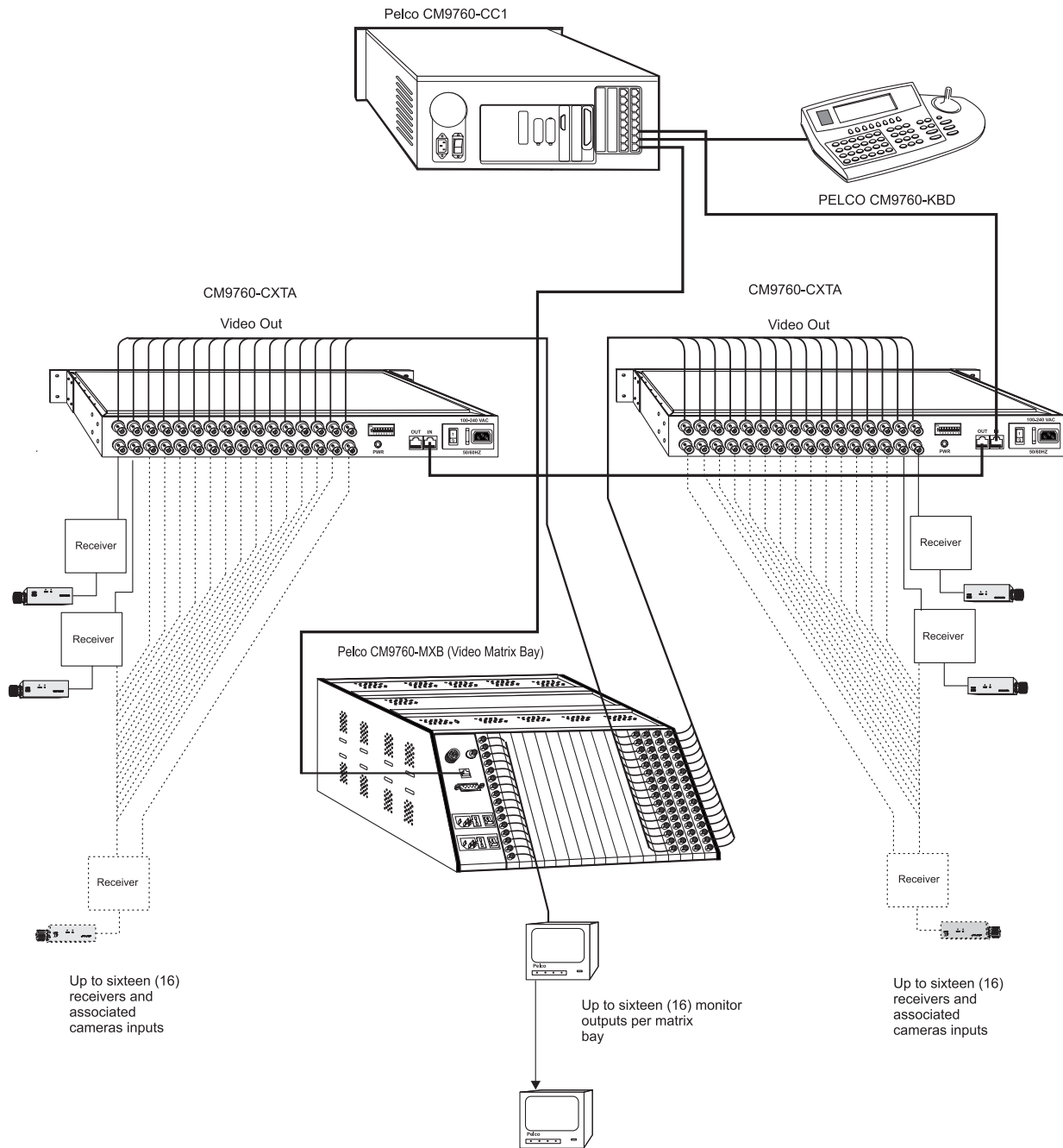

**Figure 14. 9760 System Installation**



**NOTE:** The DATA line length (between COM 1 on the DX7000 and the CXTA INPUT) can be no greater than the cable length allowed by the video loop back inputs to the DX7000 (see the Video Coax Cable Length table below).

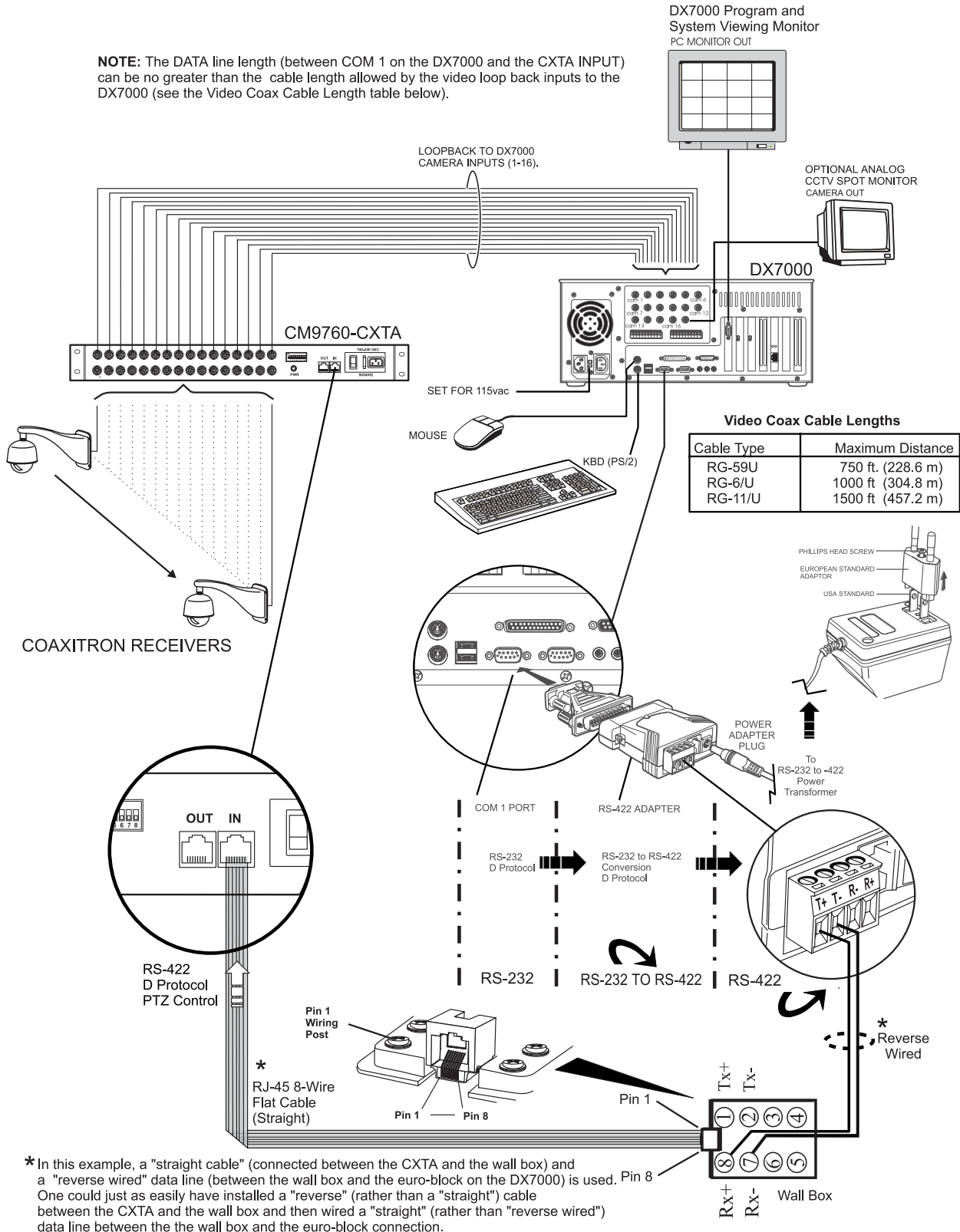

**Figure 15. DX7000 Installation**

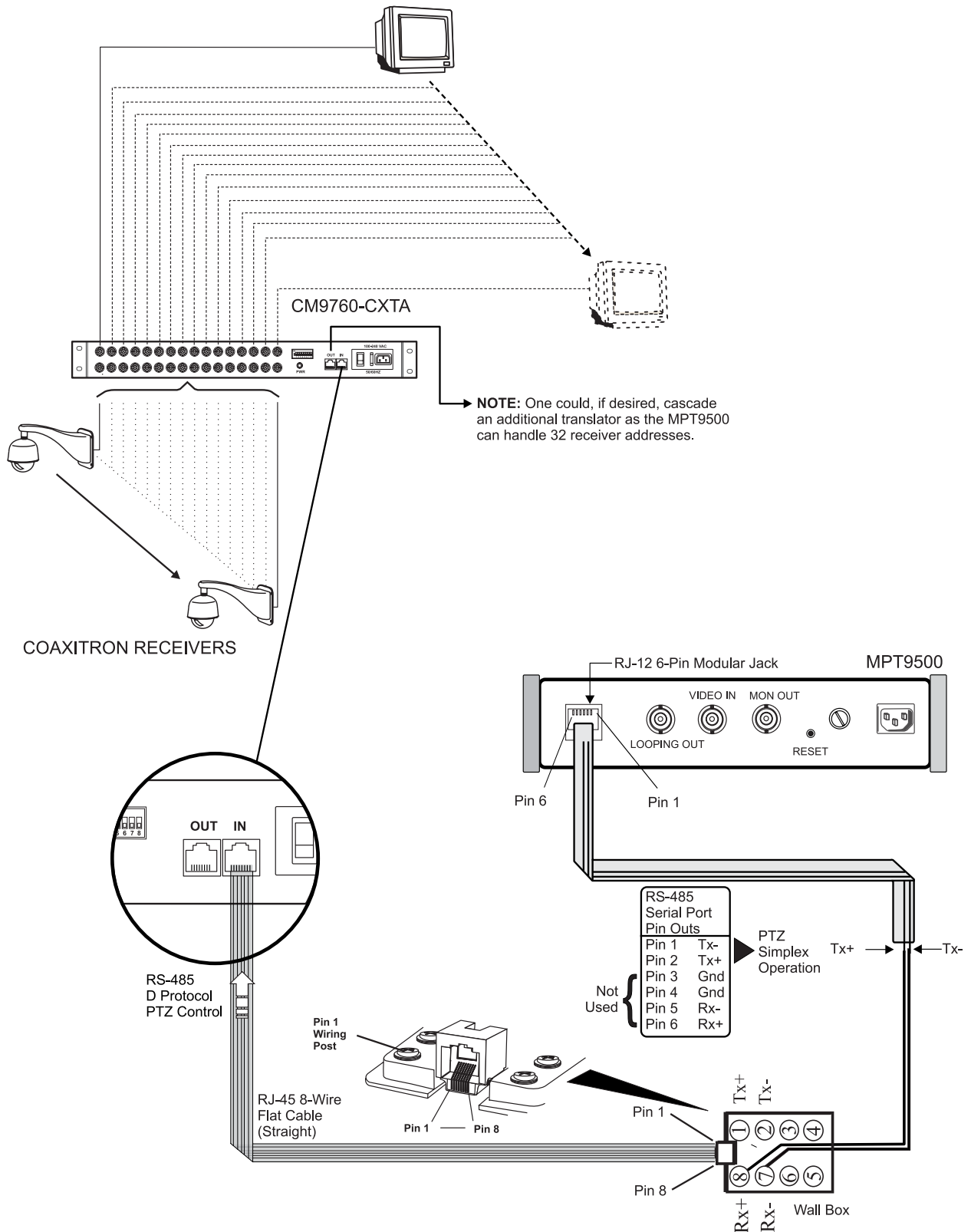

Figure 16. MPT9500 Installation

### 3.3 SOFTWARE CONSIDERATIONS

Despite the considerations given in this section to highlight aspects of required software setup, there is no substitute for consulting the respective manuals for both the controller chosen and for the receiver to be used. You must take care to match the capabilities of the controller and the receiver that the CXTA will interface. If there is a mismatch between the two, the addition of the CXTA will not solve your problem. In fact, in most cases, it will not be the problem.

With that in mind, the manual references that might be needed when installing the CXTA are listed below. Use the latest revision of the manual.

**C540M** (CM9760-KBD) – For direct mode as well as 9760 System install procedures

**C547M** (CM9760-MGR) – For 9760 System installation programming issues

**C541M** (CM9760-CC1) – For issues related to communication hookup and file manipulation during 9760 System installations

**C535M** (MPT9500) – For issues related to MPT9500 programming modes and operation

**C682M** (DX7000) – For programming and other issues related to the DX7000 Digital Video Recorder

#### 3.3.1 9760 SYSTEM

There are two files (called configuration files) that must be programmed as part of the configuration set that resides in the 9760 directory on the CM9760-CC1s hard disk. These files contain the parameters necessary for the operation of anything connected to the systems Sercom ports. For the CXTA, part of the information required was given in the COM PARAMETERS information box located at the beginning of this manual. That information is entered into the COMMS file; it is illustrated in Figure 17. In addition to the COMMS file, it is necessary to fill out the CAMERA file for the receivers that will be interfaced by the CXTA. An example of that configuration file is shown in Figure 18. Pay close attention to the annotations that accompany the screen captures in the figures.

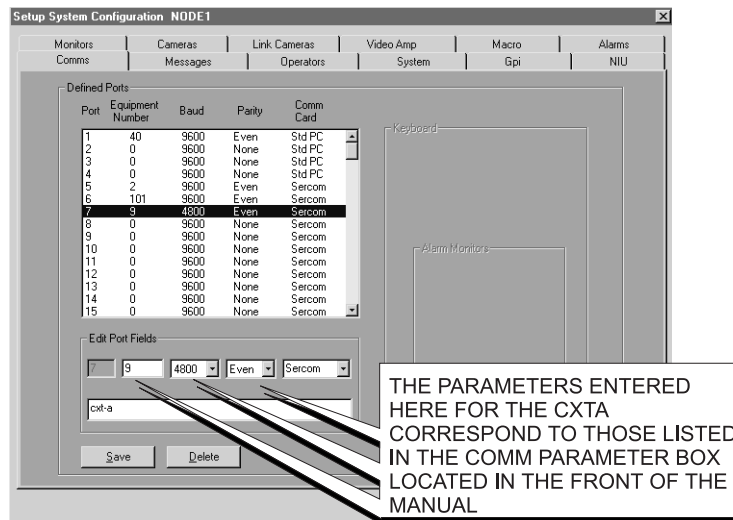

Figure 17. COMMS File Example for the CXTA

**NOTE:** When programming the 9760 KBD in direct mode, logical numbers must be assigned to any attached cameras (see the Keyboard Menu Programming portion of section 3.2.7 in the 9760 keyboard manual – C540MA).

### 3.3.2 CM9760-KBD DIRECT MODE

Consult the required manuals for setting up direct mode operation. The KBD manual (C540M) is the most important. In particular, see section 3.2.7 *Direct Camera Control/Serial Port Speeds* in the KBD manual.

### 3.3.3 MPT9500 TRANSMITTER/CONTROLLER

You must be in RS-485 mode (as shown on the MPT9500 keyboard display) in order to operate the MPT9500 in D protocol, simplex mode. The MPT9500 does not, (by default), come up in RS-485 mode when it is powered on. You must manually select it via the keyboard manual. Consult the manual for further information regarding operation and control.

### 3.3.4 DX7000 DIGITAL VIDEO RECORDER

Consult the appropriate manuals. The DX7000 has its own software management program for configuring the parameters of any device connected to it as well as a host of other options that are not covered here.

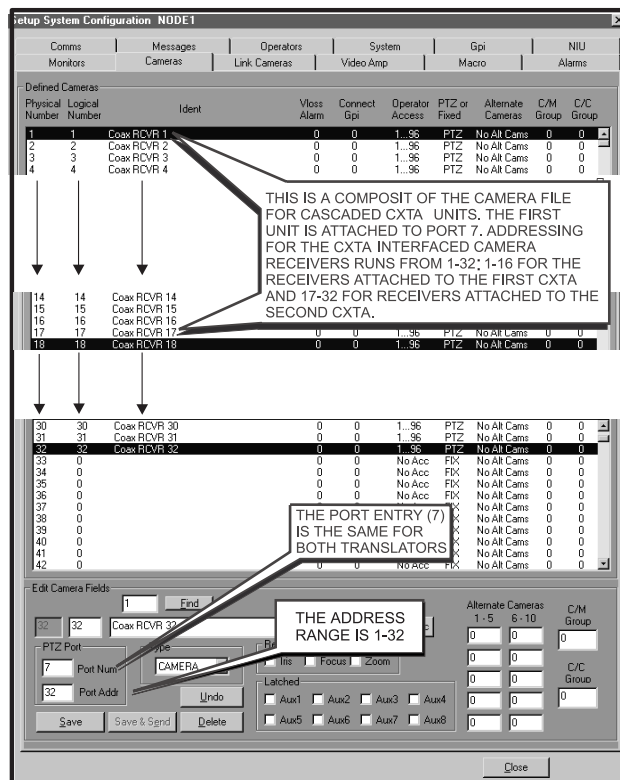

Figure 18. CAMERA Files Example for the CXTA

## SECTION IV: CXTA OPERATION

### 4.1 POWER-UP

At power up, the system microcontroller reads the configuration switch, dip switch positions, sets up the internal UART with the requested baud rate and stores the configuration settings in internal RAM. Subsequent protocol-specific commands to the translator result in the generation of the equivalent Coaxitron command and, at the appropriate time, the generated command is sent to the addressed receiver.

Additionally, the system – on power up – will automatically issue a “camera on” command if the configuration switch specifies 15-bit mode operation. This is a backward compatibility issue that should not concern the user.

### 4.2 COMMAND SET

Rather than listing the wide range of commands different transmitters are capable of transmitting and which receivers are capable of executing, we encourage you to consult directly the individual receiver manual applicable to your situation. Only in this way can you determine which functions or commands it is capable of responding to. The CM9760-CXTA translator should be able to handle the controller–receiver interface as long as the controller has issued a valid command that the receiver is capable of responding to.

### 4.3 COMMAND SET VARIATION

Some reassignment of command functions (for example, how to initiate auto-scan when an auto-scan button is not present on the transmitter/controller) are still handled by using presets. The areas in which various preset functions are invoked that you need to be aware of are listed below. In 32-bit Intercept mode, when using the 9750 system only, pattern functions are realized as follows:

- Use the preset command and,
- Set preset 95 to set pattern START point
- Set preset 94 to set pattern END point
- Call preset 95 to run pattern

In lieu of an auto-scan button, you can (for both 9750 and 9760 systems), when in 32-bit intercept mode, execute scan functions as follows:

- Set AUX 2, Call preset 99 Initiates Auto Scan
- Set AUX 3, Call preset 99 Initiates Random Scan
- Set AUX 4, Call preset 99 Initiates Frame Scan

For backward compatibility with some CX9000 series (15-bit mode) receiver/drivers, the following presets are assigned:

- Set Preset 80 Camera ON
- Set Preset 81 Camera OFF

Other than the above, a complete description the operational command set the CM9760-CXTA is capable of responding to, is almost impossible.

## SECTION V: APPENDIX

### 5.1 COMMUNICATION PARAMETERS

There is only one basic set of signal interface rules that you must consider when wiring two 9760 communication devices together. Those rules are given in step 3 below.

Frustration arises only if the information you are given does not enable you to identify those elements of the connection you need to know or if the information you need is not readily at hand. You should not be satisfied to just plug in a cable "type" because you are told to without having the slightest idea what to do if it doesn't work. It's easy enough to check the parameters for yourself so that when you do plug that cable in, you expect it to work. In fact, you should be surprised if it doesn't work.

You will never get in trouble when wiring two 9760 communication devices together, if you know and follow the information contained in the following steps. You may not always need all the information listed in all the steps, but you must always have enough information at your disposal to follow the connection rules stated in step 3.

1. You should know or be given the location of Pin 1 on each of the device input/output, plugs/connectors that you intend to wire together.
2. You should always be given the signal function that can be accessed at the Pin 1 location.
3. All communication devices in the 9760 System must be wired so that the result, if checked against the following table, is true.

**Table B.** Signal Interface Table

<b>Device A</b>	<b>Device B</b>
TX +	RX +
TX -	RX -
RX +	TX +
RX -	TX -

Given steps 1 and 2 and knowing step 3, you can successfully connect any two communication devices together to make them work. In many cases, a cable is provided. That's OK. Just check it before you use it.

Depending on the physical geometry of the cable itself, you may also need to know how to determine cable "type" before you can apply the rules above (see Figure 19). Most devices in the 9760 family use RJ-45, 8-pin, flat cable to connect to each other. This is rigid cable so, in effect, it has a cable "color" run across its width. This fact is used to determine the cable type as either "straight" (parallel) or "reverse" (flipped).

If a cable is "straight", then pin 1 at one end of the cable goes to pin 1 at the opposite end of the cable. If the connecting plugs on this cable interface two devices, then pin 1 on device one would physically be connected to pin 1 on device two. Straight cable is used in devices where the signal pin run on the first device is opposite that of the second device. If a cable is "reverse", then pin 1 on one end of the cable goes to pin 8 at the opposite end of the cable. If the connecting plugs on this cable interfaced two devices, then pin 1 on device one physically connects to pin 8 on device two. A reverse cable is used in devices where the signal pin run on the first device is the same as that of the second device.

#### Compared "Color Run" is in Opposite Direction

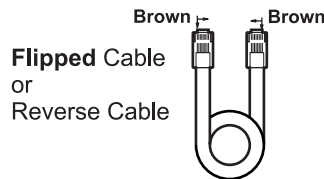

Flipped Cable  
or  
Reverse Cable

To identify a cable type, physically orient the RJ-45 cable as depicted in the illustrations. Orient the cable side by side, tab side down. Use the "color-run" of the wires to determine cable type and use the cable type appropriate to the situation.

#### Compared "Color Run" is in Same Direction

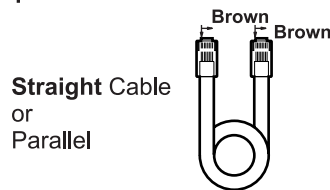

Straight Cable  
or  
Parallel

**Figure 19.** Cable Identification

The physical wiring differences for "straight" versus "flipped" came about because of the relationship of the physical orientation of the attached plugs when the cable is created. Almost all pieces of equipment connected to the CM9760-CC1 utilize "flipped" cables because there is a concerted effort to make the signal available at Pin 1 on all devices be TX+. Thus, use of a "flipped" cable fulfills the requirement of step 3. TX+ (Controller) ends up at RX+ (Pin 8) on the connected device, because the signal runs from Pin 1 to Pin 8 on each device is the same. Some devices predate this effort or are simply wired in a different manner. For these, either a straight cable or a non-standard wiring interface is used. How to identify a "straight" cable from a "flipped" one is illustrated in Figure 19.

Sometimes, a physical disparity exists between two connecting devices such that the wiring geometry you start with at one end is different from that at the other end. Nevertheless, the wiring relationships stated in step 3 must be satisfied. Examples of this occurred in the manual when connecting the CXTA to the DX7000 or to the MPT9500 (see Figures 15 and 16, respectively).

Both wiring scenarios utilized a wall block, which is part of a "wiring kit" that can be obtained from Pelco.

**NOTE:** Do not be confused by the pasted-in wiring label located in the cap of the wiring block that you sometimes see. Although signal functions are labeled for each terminal pin, remember that this is a passive device and that the actual signal that appears on any terminal pin is the one that you put there. Keep the following in mind:

1. Plan the wiring for each run ahead of time. Be surprised if it doesn't work.
2. Verify any manual instructions that specify attachment of a certain cable "type". Check to be sure the right cable is packed and that the instructions given don't run contrary to the previously stated connection rules for signal interfaces.

## 5.2 CABLE PARAMETERS

Data communication cables are used in the CM9760 system to connect required equipment to appropriate data communication ports on the CC1, which are either RS-232 or RS-422 driven.

The characteristics of the cable chosen (if not supplied) depends, first of all, on the driver type it interfaces.

- For RS-232 driven ports, such as Com 1 and Com 2, the cable used must meet less stringent communication requirements than that required for driven ports RS-422. The cable for RS-232 communications supports the following driver characteristics:
  1. It is single ended – one driver and one receiver.
  2. It is unbalanced—a voltage level with respect to system ground drives the communications link.
  3. It is limited to low data rates.
  4. It is limited to local use: 50 feet or less for synchronized data; 100 to 200 feet for asynchronous data.
- For RS-422 driven ports, such as the 32 Sercom ports on the rear of the CC1, the cable chosen by the user must support the following driver characteristics:
  1. It is single ended, multi-drop capable.
  2. It is balanced—a differential voltage drives the communications link.
  3. It handles relatively high data rates. There is a trade off between data rate and cable length (theoretically, up to 4,000 feet [1,220 m] @ 100Kbps) (see Figure 20).
  4. It is used for both local and remote hookup of system devices; for example, remote hookup of 9760 keyboards attached to the CC1.

**Figure 19: Information Box**

BPS or bps means or = bits per second.

Baud = # of signal changes per second.

In the recent past, bps and baud rate were equivalent, that is, 300 bps and 300 baud, for example, were the same.

Two things happened which eventually separated the use of bps and baud as being equal.

1. It became physically possible to transmit more than one bit per signal change through variations in amplitude, frequency, and/or phase.
2. A physical bandwidth limit on voice-grade phone lines made it difficult to reach baud rates greater than 2400. Most modems do not operate at a speed greater than this.

A modem operating at a Pelco referenced baud rate of 9600 is, most likely, a 2400 baud modem operating at 9600 bps (or a 4:1 compression ratio;  $4 \times 2400 = 9600$ ) because of the bps manipulation mentioned above.

Therefore, for higher speed modems and for the graph illustrated in Figure 20, modem speeds are listed and referenced at a bps rate. For convenience, Pelco still refers to modem speeds in all its communication parameter lists by using the baud rate (a misnomer), even though the proper reference, in most cases, is bps. In Figure 20, the approximate baud rate range of Pelco equipment is highlighted against the bps per distance chart.

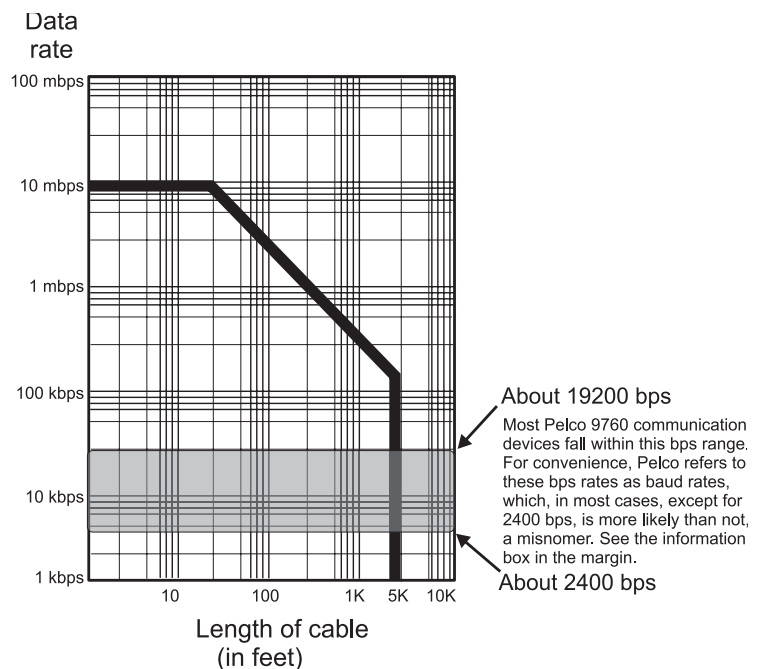

**Figure 20. Data Rate vs. Cable Length**



**NOTE:** For short distances that exceed the cable length supplied, you might consider the use of CAT 5 cable (for distances up to 300 feet). This cable is RS-422 compliant (up to the length mentioned) and is used primarily for Ethernet connections within networks. Moreover, it is readily available (because of demand) and cost is reasonable (because it is less difficult to manufacture).

Most of the time, connection cables are supplied with the device. As long as the supplied cable is appropriate, no problem arises. If the cable length needed is greater than that supplied, a problem arises for the installer/specifier as to the type of cable to use. One of the most common hookup extensions is the remote hookup of a 9760 keyboard. The following highlights the issues involved and ends with some recommendations.

For remote installation of a keyboard, the user must supply a cable of appropriate length that supports the TIA/EIA-422-B (RS-422) communication standard. The example in Figure 21 shows a keyboard placed 2,000 feet (610 m) from the CC1 via the user-supplied cable. Junction boxes (phone boxes) are used to facilitate the RJ-45-to-cable connection points at either end of the run. Note that only signal wires and ground are run through the cable itself (five of the six available wires are used in the example). The transformer serves to pass on the data signal and to supply power to the keyboard at the keyboard end.

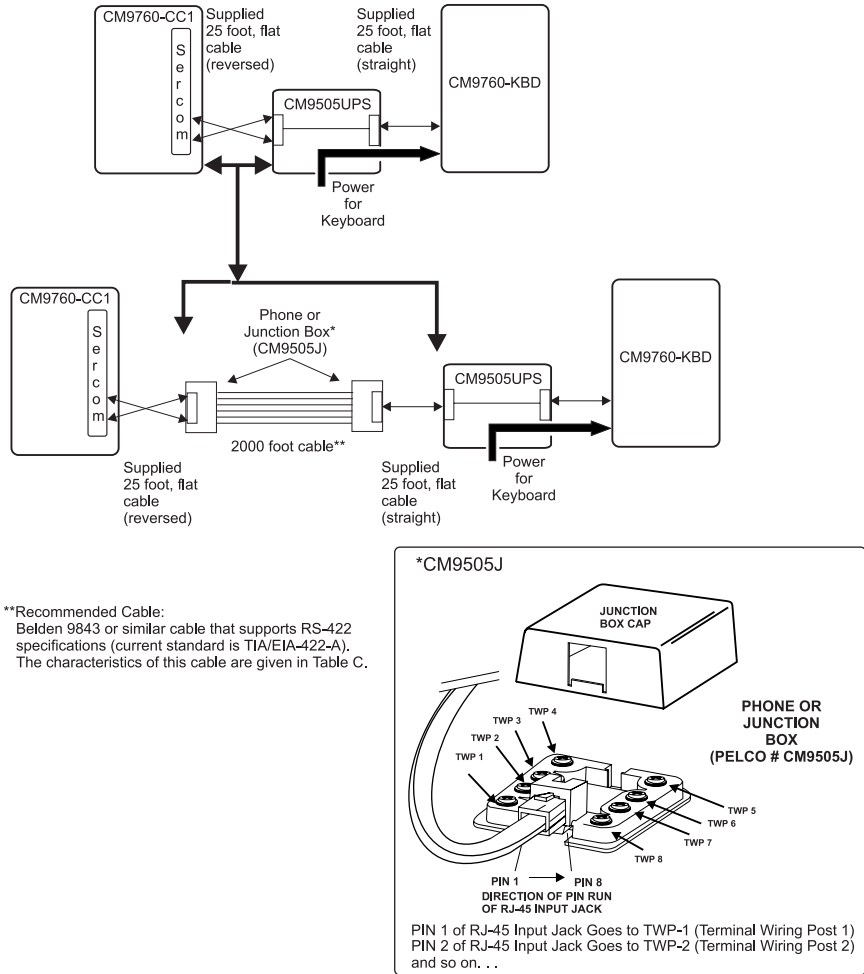
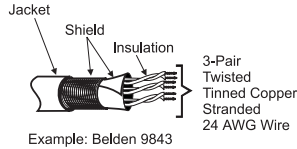

Figure 21. Remote Wiring a CM9760-KBD

Although the communication link can be as far away as 4,000 feet (1,220 m) (per Figure 20), this is theoretical. Pelco recommends that for distances greater than 2,000 feet (610 m) a CM9505UPS-422 power supply, with data repeater, be used. In any case, Pelco recommends using a cable similar to Belden 9843 that meets or exceeds the support requirements for TIA/EIA-422 applications. Table C is taken directly from the FULL TECHNICAL SPECS page in Belden's Cable Catalog located on their company web site.

**Table C.** (TIA/EIA-422) Cable Example

**9843**



AWG	STRANDED	TYPE	INSULATION
24	(7 x 32)	TC – Tinned Copper	PE – Polyethylene
SHIELD	JACKET	# PAIR	# TRIADS
Aluminum Foil-Polyester Tape/Braid Shield	PVC – Polyvinyl Chloride	3	0

NOMINAL OD (in.)	INSULATION THICKNESS (in.)	JACKET THICKNESS (Pf/FT)	NOMINAL CAPACITANCE	NOMINAL CONDUCTOR DCR (/M')	NOMINAL VELOCITY OF PROPAGATION (%)	NOMINAL IMPEDANCE (ohms)
.3600	.00000	.0000	12.800	24.000	66.0	120.0

\* TIA/EIA-422-B is the full name of the current standard for what is commonly referred to as RS-422. The prefix "RS", which stands for "recommended standard", was used by the EIA (Electronic Industries Association) as the name for some of its standards. The "RS-" prefix was dropped by the EIA in 1986 and standards were simply referred to with the EIA- prefix. In 1988 TIA (Telecommunication Industries Association) was a working group of the EIA and the reference evolved to a combined EIA/TIA- prefix. When TIA became ANSI (American National Standards Institute) accredited, the acronym order was reversed to TIA/EIA-. In 1992 TIA spun off from EIA and merged with US Telecommunications Suppliers Association (USTSA). From about that time to the present, the full standard has been referenced as ANSI/TIA/EIA-422-B, where "B" is the latest revision of the standard. Normally the standard is written simply as TIA/EIA-422. In all probability, that will be shortened to just TIA-422 at some point in the future. However, everyone has used the "RS-" prefix reference for so long that it may be some time before its use disappears, if at all.

## SECTION VI: GENERAL

### 6.1 SPECIFICATIONS

#### **ELECTRICAL**

Input Voltage: 100-240 VAC, 50/60 Hz, auto-ranging

Power  
Consumption: 15VA

Coaxitron Ports  
Video Format: NTSC or PAL  
Video Level:  $\pm 6$ dB minimum  
Coaxitron  
Level: 0.7 V peak

Data Ports  
Input: RS-422, 8-pin, 4-wire, RJ-45 connector. Dip switch selectable baud-rate, even parity.

Output: RS-422, 8-pin, 4-wire, RJ-45 connector. Dip switch selectable baud-rate, even parity.

Indicators: 1 power LED, Green

Fusing: 1/4A, 250 VAC

#### **GENERAL**

Dimensions  
Base only: 17.40 (W) x 10.625 (D) x 1.75 (H) inches (44.20 x 26.99 x 4.44 cm)  
With Ears for  
Rack Mount &  
BNCs: 19.00 (W) x 11.125 (D) x 1.75 (H) inches (48.26 cm x 28.26 cm x 4.44 cm)

Operating  
Temperature: 32°F to 158°F (0° to 70°C)

Weight: 5.74 lb (2.60 kg)

Rating: Meets NEMA 1 standards

#### **MECHANICAL**

Connectors  
Video: BNC type (32 total)  
Power: 3-wire #18 AWG  
RS-422: RJ-45 (8-pin), connectors (2 total)



This equipment contains electrical or electronic components that must be recycled properly to comply with Directive 2002/96/EC of the European Union regarding the disposal of waste electrical and electronic equipment (WEEE). Contact your local dealer for procedures for recycling this equipment.

 Green The materials used in the manufacture of this document and its components are compliant to the requirements of Directive 2002/95/EC.

## 6.2 REGULATORY NOTICES

This equipment has been tested and found to comply with the limits of a Class B digital device, pursuant to part 15 of the FCC rules. These limits are designed to provide reasonable protection against harmful interference in a residential installation. This equipment generates, uses, and can radiate radio frequency energy and, if not installed and used in accordance with the instructions, may cause harmful interference to radio communications. However there is no guarantee that the interference will not occur in a particular installation. If this equipment does cause harmful interference to radio or television reception, which can be determined by turning the equipment off and on, the user is encouraged to try and correct the interference by one or more of the following measures:

- Reorient or relocate the receiving antenna.
- Increase the separation between the equipment and the receiver.
- Connect the equipment into an outlet on a circuit different from that to which the receiver is connected.
- Consult the dealer or an experienced radio/TV technician for help.

### PRODUCT WARRANTY AND RETURN INFORMATION

#### WARRANTY

Pelco will repair or replace, without charge, any merchandise proved defective in material or workmanship **for a period of one year** after the date of shipment.

Exceptions to this warranty are as noted below:

- Five years on FT/FR8000 Series fiber optic products.
- Three years on Genex® Series products (multiplexers, server, and keyboard).
- Three years on Camclosure® and fixed camera models, except the CC3701H-2, CC3701H-2X, CC3751H-2, CC3651H-2X, MC3651H-2, and MC3651H-2X camera models, which have a five-year warranty.
- Two years on standard motorized or fixed focal length lenses.
- Two years on Legacy®, CM6700/CM6800/CM9700 Series matrix, and DF5/DF8 Series fixed dome products.
- Two years on Spectra®, Esprit®, ExSite™, and PS20 scanners, including when used in continuous motion applications.
- Two years on Esprit® and WW5700 Series window wiper (excluding wiper blades).
- Eighteen months on DX Series digital video recorders, NVR300 Series network video recorders, and Endura™ Series distributed network-based video products.
- One year (except video heads) on video cassette recorders (VCRs). Video heads will be covered for a period of six months.
- Six months on all pan and tilts, scanners or preset lenses used in continuous motion applications (that is, preset scan, tour and auto scan modes).

Pelco will warrant all replacement parts and repairs for 90 days from the date of Pelco shipment. All goods requiring warranty repair shall be sent freight prepaid to Pelco, Clovis, California. Repairs made necessary by reason of misuse, alteration, normal wear, or accident are not covered under this warranty.

Pelco assumes no risk and shall be subject to no liability for damages or loss resulting from the specific use or application made of the Products. Pelco's liability for any claim, whether based on breach of contract, negligence, infringement of any rights of any party or product liability, relating to the Products shall not exceed the price paid by the Dealer to Pelco for such Products. In no event will Pelco be liable for any special, incidental or consequential damages (including loss of use, loss of profit and claims of third parties) however caused, whether by the negligence of Pelco or otherwise.

The above warranty provides the Dealer with specific legal rights. The Dealer may also have additional rights, which are subject to variation from state to state.

If a warranty repair is required, the Dealer must contact Pelco at (800) 289-9100 or (559) 292-1981 to obtain a Repair Authorization number (RA), and provide the following information:

1. Model and serial number
2. Date of shipment, P.O. number, Sales Order number, or Pelco invoice number
3. Details of the defect or problem

If there is a dispute regarding the warranty of a product which does not fall under the warranty conditions stated above, please include a written explanation with the product when returned.

Method of return shipment shall be the same or equal to the method by which the item was received by Pelco.

#### RETURNS

In order to expedite parts returned to the factory for repair or credit, please call the factory at (800) 289-9100 or (559) 292-1981 to obtain an authorization number (CA number if returned for credit, and RA number if returned for repair).

All merchandise returned for credit may be subject to a 20% restocking and refurbishing charge.

Goods returned for repair or credit should be clearly identified with the assigned CA or RA number and freight should be prepaid. Ship to the appropriate address below.

*If you are located within the continental U.S., Alaska, Hawaii or Puerto Rico, send goods to:*

Service Department  
Pelco  
3500 Pelco Way  
Clovis, CA 93612-5699

*If you are located outside the continental U.S., Alaska, Hawaii or Puerto Rico and are instructed to return goods to the USA, you may do one of the following:*

If the goods are to be sent by a COURIER SERVICE, send the goods to:

Pelco  
3500 Pelco Way  
Clovis, CA 93612-5699 USA

If the goods are to be sent by a FREIGHT FORWARDER, send the goods to:

Pelco c/o Expeditors  
473 Eccles Avenue  
South San Francisco, CA 94080 USA  
Phone: 650-737-1700  
Fax: 650-737-0933

### REVISION HISTORY

Manual #	Date	Comments
C539M	1/98	Original version.
	8/01	Baud reference correction.
C539M-A	12/01	Completely revised and updated to include added protocols, and appendix.

Pelco, the Pelco Logo, Camclosure, Esprit, Genex, Legacy, and Spectra are registered trademarks of Pelco. Intercept, Endura, and ExSite are trademarks of Pelco.

© Copyright 2001, Pelco. All rights reserved.

## Free Manuals Download Website

<http://myh66.com>

<http://usermanuals.us>

<http://www.somanuals.com>

<http://www.4manuals.cc>

<http://www.manual-lib.com>

<http://www.404manual.com>

<http://www.luxmanual.com>

<http://aubethermostatmanual.com>

Golf course search by state

<http://golfingnear.com>

Email search by domain

<http://emailbydomain.com>

Auto manuals search

<http://auto.somanuals.com>

TV manuals search

<http://tv.somanuals.com>