



3500 Pelco Way,
Clovis, CA 93612-5699
USA

In North America & Canada:
Tel (800) 289-9100
FAX (800) 289-9150

International Customers:
Tel +1 (559) 292-1981
FAX +1 (559) 348-1120

www.pelco.com

C421M-D (4/00)

HT10 Series

Liquid-Cooled Enclosure

IMPORTANT SAFEGUARDS AND WARNINGS

Prior to installation and use of this product, the following WARNINGS should be observed.

1. Installation and servicing should only be done by qualified service personnel and conform to all local codes.
2. Unless the unit is specifically marked as a NEMA Type 3, 3R, 3S, 4, 4X, 6 or 6P enclosure, it is designed for indoor use only and it must not be installed where exposed to rain and moisture.
3. Only use replacement parts recommended by Pelco.
4. After replacement/repair of this unit's electrical components, conduct a resistance measurement between line and exposed parts to verify the exposed parts have not been connected to line circuitry.
5. The installation method and materials should be capable of supporting four times the weight of the enclosure, pan/tilt, camera and lens combination.
6. Use or mount this enclosure so that it is positioned not less than 91 degrees and not more than 180 degrees when considering 12 o'clock to be 0 degrees and 6 o'clock to be 180 degrees.
7. Only Nema 3R liquid tight conduit should be used in all outdoor applications.

The product and/or manual may bear the following marks:



This symbol indicates that dangerous voltage constituting a risk of electric shock is present within this unit.



This symbol indicates that there are important operating and maintenance instructions in the literature accompanying this unit.

CAUTION:

RISK OF ELECTRIC SHOCK.
DO NOT OPEN.

Please thoroughly familiarize yourself with the information in this manual prior to installation and operation.

DESCRIPTION

The products in the HT10 Series are liquid-cooled enclosures designed for high temperature applications.

The stainless steel enclosure features two separate double-walled cooling jackets that protect the camera and lens and other sensing devices housed within the unit.

Models

HT10V	High temperature enclosure with Vycor® window; window suitable in temperatures up to 1300°F (705°C)
HT10V/RC	Same as the HT10V except Vycor window has an infrared reflective coating for environments where high levels of radiant heat are encountered; window suitable in temperatures up to 1300°F (705°C)

INSTALLATION

① Mount the Enclosure

Determine the mounting location. Attach the enclosure as follows:

1. Remove the enclosure from the cradle by loosening the screw clamps on the stainless steel straps.
2. Attach the cradle to the mounting surface (mount, pan/tilt, etc.).
3. Center the enclosure on the cradle and secure it with the stainless steel straps.

② Connect Cooling Systems

The HT10 Series enclosure features two distinct cooling systems. One cooling jacket is located in the body of the unit and the other is strategically placed around the viewing window. (Refer to Figure 1.)

To make cooling system connections:

1. Use hoses with a 3/8-inch NPT fitting (not supplied).
2. Connect the enclosure to a coolant reservoir. A shut-off valve should be installed in the input line to regulate coolant flow.
3. Make input connections. Input hoses are connected to the IN line fittings located at the top and rear of the enclosure.
4. Make output connections. Output hoses are connected to the OUT line fittings located at the top and rear of the enclosure. The output line should not be restricted, so that the 35 psi working pressure is not exceeded. The liquid flow rate is determined by the temperature of the coolant as it enters the enclosure and the temperature gradient in which the enclosure is installed.

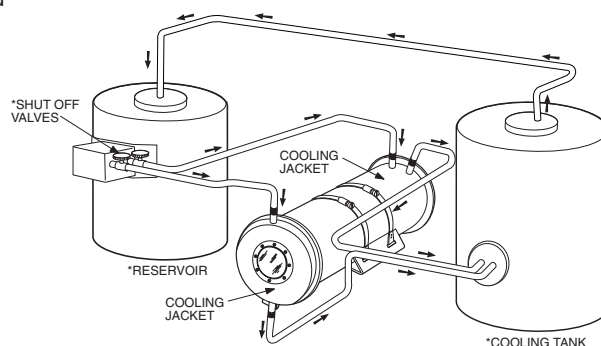

*LOCATION OF EQUIPMENT IS NOT INTENDED FOR ANY SPECIFIC APPLICATION.

NOTE: GENERAL DIAGRAM - PUMP, INSULATION, CHECK VALVES AND TYPE OF PLUMBING NOT SHOWN.

Figure 1. Coolant Hook-Up, General Installation

③ Install Camera

To mount the camera on the sled:

1. Remove the rear plate of the enclosure.
2. Remove the camera sled:
 - a. Loosen the 1/4-20 hex socket head screw with the 3/16-inch Allen wrench (supplied).
 - b. Slide the sled out of the enclosure.
3. Mount the camera and lens onto the sled:
 - a. Extend the lens to the maximum length before positioning the camera and lens.
 - b. Position the camera and lens so that they do not extend beyond the track.
 - c. Fasten the camera and lens to the sled with the two 1/4-20 x .375-inch Phillips screws (supplied).
4. Reinstall the camera sled.
5. Feed the cable(s) through the feedthrough hole in the rear plate of the enclosure. Make all equipment connections; refer to the installation manuals supplied with the equipment.

IMPORTANT: Check coolant flow rate periodically to ensure that sediment or deposits are not restricting flow. This will prevent heat from building up in the enclosure, or steam from developing in the water jacket.

SPECIFICATIONS

MECHANICAL

Cooling Pipe Connections: Standard 3/8-inch NPT pipe fittings

Suggested Operating Pressure: 35 psi, approximately 2.3 gallons/minute

Cooling Jacket Volume: Approximately 3 gallons

GENERAL

Construction: Type 304 stainless steel

Finish: Silver-gray paint

Viewing Window

HT10V: .25-inch (6.35 mm) thick Vycor glass

HT10V/RC: .25-inch (6.35 mm) thick Vycor glass with infrared coating

Window

Temperature Range: Up to 1300°F (705°C)

Maximum

Camera and Lens Size: Accepts camera and lens combinations (including BNC connector) up to:
5.50 (H) x 5.00 (W) x 22.00 (L) inches
(13.97 x 12.70 x 55.88 cm) or
8 (D) x 22 (L) inches
(20.32 x 55.88 cm)

Weight

Dry: 50 lb (22.5 kg)

With coolant: 70 lb (31.5 kg) approx.

Rating:

NEMA 1 (HT10V)

(Design and product specifications subject to change without notice.)

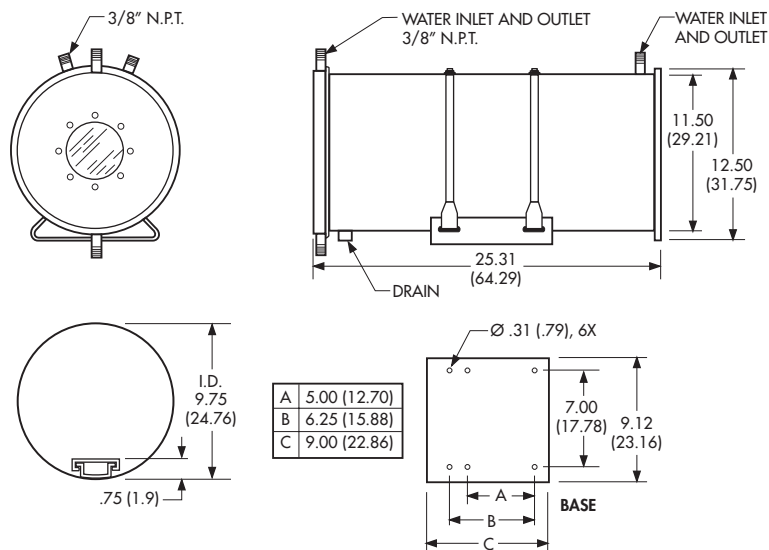

NOTE: VALUES IN PARENTHESES ARE CENTIMETERS; ALL OTHERS ARE IN INCHES.

Figure 2. HT10 Series Dimension Drawing

PRODUCT WARRANTY AND RETURN INFORMATION

WARRANTY

Pelco will repair or replace, without charge, any merchandise proved defective in material or workmanship **for a period of one year** after the date of shipment.

Exceptions to this warranty are as noted below:

- Five years on FT/FR8000 Series fiber optic products.
- Three years on Genex® Series products (multiplexers, server, and keyboard).
- Three years on Camclosure® and fixed camera models, except the CC3701H-2, CC3701H-2X, CC3751H-2, CC3651H-2X, MC3651H-2, and MC3651H-2X camera models, which have a five-year warranty.
- Two years on standard motorized or fixed focal length lenses.
- Two years on Legacy®, CM6700/CM6800/CM9700 Series matrix, and DF5/DF8 Series fixed dome products.
- Two years on Spectra®, Esprit®, ExSite™, and PS20 scanners, including when used in continuous motion applications.
- Two years on Esprit® and WW5700 Series window wiper (excluding wiper blades).
- Eighteen months on DX Series digital video recorders, NVR300 Series network video recorders, and Endura™ Series distributed network-based video products.
- One year (except video heads) on video cassette recorders (VCRs). Video heads will be covered for a period of six months.
- Six months on all pan and tilts, scanners or preset lenses used in continuous motion applications (that is, preset scan, tour and auto scan modes).

Pelco will warrant all replacement parts and repairs for 90 days from the date of Pelco shipment. All goods requiring warranty repair shall be sent freight prepaid to Pelco, Clovis, California. Repairs made necessary by reason of misuse, alteration, normal wear, or accident are not covered under this warranty.

Pelco assumes no risk and shall be subject to no liability for damages or loss resulting from the specific use or application made of the Products. Pelco's liability for any claim, whether based on breach of contract, negligence, infringement of any rights of any party or product liability, relating to the Products shall not exceed the price paid by the Dealer to Pelco for such Products. In no event will Pelco be liable for any special, incidental or consequential damages (including loss of use, loss of profit and claims of third parties) however caused, whether by the negligence of Pelco or otherwise.

The above warranty provides the Dealer with specific legal rights. The Dealer may also have additional rights, which are subject to variation from state to state.

If a warranty repair is required, the Dealer must contact Pelco at (800) 289-9100 or (559) 292-1981 to obtain a Repair Authorization number (RA), and provide the following information:

1. Model and serial number
2. Date of shipment, P.O. number, Sales Order number, or Pelco invoice number
3. Details of the defect or problem

If there is a dispute regarding the warranty of a product which does not fall under the warranty conditions stated above, please include a written explanation with the product when returned.

Method of return shipment shall be the same or equal to the method by which the item was received by Pelco.

RETURNS

In order to expedite parts returned to the factory for repair or credit, please call the factory at (800) 289-9100 or (559) 292-1981 to obtain an authorization number (CA number if returned for credit, and RA number if returned for repair).

All merchandise returned for credit may be subject to a 20% restocking and refurbishing charge.

Goods returned for repair or credit should be clearly identified with the assigned CA or RA number and freight should be prepaid. Ship to the appropriate address below.

If you are located within the continental U.S., Alaska, Hawaii or Puerto Rico, send goods to:

Service Department
Pelco
3500 Pelco Way
Clovis, CA 93612-5699

If you are located outside the continental U.S., Alaska, Hawaii or Puerto Rico and are instructed to return goods to the USA, you may do one of the following:

If the goods are to be sent by a COURIER SERVICE, send the goods to:

Pelco
3500 Pelco Way
Clovis, CA 93612-5699 USA

If the goods are to be sent by a FREIGHT FORWARDER, send the goods to:

Pelco c/o Expeditors
473 Eccles Avenue
South San Francisco, CA 94080 USA
Phone: 650-737-1700
Fax: 650-737-0933

REVISION HISTORY

Manual #	Date	Comments
C421M	3/91	Original version.
C421M-A	3/92	Warranty page added.
C421M-B	12/93	New format, dimension drawing; updated models, options, mounts.
C421M-C	2/95	WCAL instructions added. Figure 1 added. Per ECO94-198, changed part # for infrared coated glass.
C421M-D	2/00	Updated manual to new format. Created separate manual for WCAL.
	4/00	Revised temperature specifications.

Free Manuals Download Website

<http://myh66.com>

<http://usermanuals.us>

<http://www.somanuals.com>

<http://www.4manuals.cc>

<http://www.manual-lib.com>

<http://www.404manual.com>

<http://www.luxmanual.com>

<http://aubethermostatmanual.com>

Golf course search by state

<http://golfingnear.com>

Email search by domain

<http://emailbydomain.com>

Auto manuals search

<http://auto.somanuals.com>

TV manuals search

<http://tv.somanuals.com>