



3500 Pelco Way
Clovis, CA 93612-5699
USA

In North America & Canada:
Tel (800) 289-9100
FAX (800) 289-9150

International Customers:
Tel +1(559) 292-1981
FAX +1(559) 348-1120

www.pelco.com

C1997M (3/01) RMQ10T Rack Mount Kit

IMPORTANT SAFEGUARDS AND WARNINGS

Prior to installation and use of this product, the following WARNINGS should be observed.

1. Installation and servicing should only be done by qualified service personnel and conform to all local codes.
2. Only use replacement parts recommended by Pelco.
3. Use only installation methods and materials capable of supporting four times the maximum specified load.

Please thoroughly familiarize yourself with the information in this manual prior to installation and operation.

DESCRIPTION

The RMQ10T Rack Mount Kit is designed to mount a single PMC10A, 10-inch monitor to any standard 19-inch (48.26 cm) wide console or rack configuration.

The RMQ10T Rack Mount Kit contains the following parts:

Qty Description

- | | |
|---|--|
| 2 | Monitor mounting brackets |
| 2 | Handles |
| 8 | Nylon finishing washers (black) |
| 8 | Screws, 10-32 x .75-inch, Phillips, pan head (black) |
| 4 | Screws, 10-32 x .50-inch, Phillips, pan head |
| 4 | #10 locking washers |
| 4 | Screws, 4 x 12-mm, Phillips, pan head (black) |
| 4 | #8 locking washers |

INSTALLATION

To rack mount the PMC10A monitor, refer to Figure 1 and do the following:

1. Disconnect the monitor from its power supply.
2. Attach the handles to the mounting brackets using the four 10-32 x .50-inch screws and locking washers.
3. Remove the two screws from the left side of the monitor and the two screws from the right side.
4. Use the hardware supplied with the rack mount kit and attach the monitor mounting brackets to the sides of the monitor. Use two 4 x 12-mm screws, locking washers, and flat washers on each side.
5. Use the eight supplied 10-32 x .75-inch black screws and finishing washers and mount the monitor assembly to a 19-inch (48.26 cm) rack or console. Installation of the monitor assembly may require two persons.
6. Reconnect the monitor to its power supply.

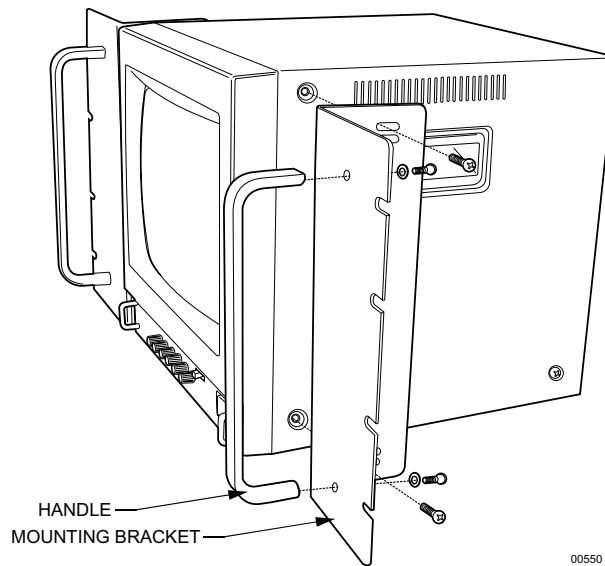

Figure 1. RMQ10T Rack Mount Kit Installation

PRODUCT WARRANTY AND RETURN INFORMATION

WARRANTY

Pelco will repair or replace, without charge, any merchandise proved defective in material or workmanship **for a period of one year** after the date of shipment.

Exceptions to this warranty are as noted below:

- Five years on FT/FR8000 Series fiber optic products.
- Three years on Genex® Series products (multiplexers, server, and keyboard).
- Three years on Camclosure® and fixed camera models, except the CC3701H-2, CC3701H-2X, CC3751H-2, CC3651H-2X, MC3651H-2, and MC3651H-2X camera models, which have a five-year warranty.
- Two years on standard motorized or fixed focal length lenses.
- Two years on Legacy®, CM6700/CM6800/CM9700 Series matrix, and DF5/DF8 Series fixed dome products.
- Two years on Spectra®, Esprit®, ExSite™, and PS20 scanners, including when used in continuous motion applications.
- Two years on Esprit® and WW5700 Series window wiper (excluding wiper blades).
- Eighteen months on DX Series digital video recorders, NVR300 Series network video recorders, and Endura™ Series distributed network-based video products.
- One year (except video heads) on video cassette recorders (VCRs). Video heads will be covered for a period of six months.
- Six months on all pan and tilts, scanners or preset lenses used in continuous motion applications (that is, preset scan, tour and auto scan modes).

Pelco will warrant all replacement parts and repairs for 90 days from the date of Pelco shipment. All goods requiring warranty repair shall be sent freight prepaid to Pelco, Clovis, California. Repairs made necessary by reason of misuse, alteration, normal wear, or accident are not covered under this warranty.

Pelco assumes no risk and shall be subject to no liability for damages or loss resulting from the specific use or application made of the Products. Pelco's liability for any claim, whether based on breach of contract, negligence, infringement of any rights of any party or product liability, relating to the Products shall not exceed the price paid by the Dealer to Pelco for such Products. In no event will Pelco be liable for any special, incidental or consequential damages (including loss of use, loss of profit and claims of third parties) however caused, whether by the negligence of Pelco or otherwise.

The above warranty provides the Dealer with specific legal rights. The Dealer may also have additional rights, which are subject to variation from state to state.

If a warranty repair is required, the Dealer must contact Pelco at (800) 289-9100 or (559) 292-1981 to obtain a Repair Authorization number (RA), and provide the following information:

1. Model and serial number
2. Date of shipment, P.O. number, Sales Order number, or Pelco invoice number
3. Details of the defect or problem

If there is a dispute regarding the warranty of a product which does not fall under the warranty conditions stated above, please include a written explanation with the product when returned.

Method of return shipment shall be the same or equal to the method by which the item was received by Pelco.

RETURNS

In order to expedite parts returned to the factory for repair or credit, please call the factory at (800) 289-9100 or (559) 292-1981 to obtain an authorization number (CA number if returned for credit, and RA number if returned for repair).

All merchandise returned for credit may be subject to a 20% restocking and refurbishing charge.

Goods returned for repair or credit should be clearly identified with the assigned CA or RA number and freight should be prepaid. Ship to the appropriate address below.

If you are located within the continental U.S., Alaska, Hawaii or Puerto Rico, send goods to:

Service Department
Pelco
3500 Pelco Way
Clovis, CA 93612-5699

If you are located outside the continental U.S., Alaska, Hawaii or Puerto Rico and are instructed to return goods to the USA, you may do one of the following:

If the goods are to be sent by a COURIER SERVICE, send the goods to:

Pelco
3500 Pelco Way
Clovis, CA 93612-5699 USA

If the goods are to be sent by a FREIGHT FORWARDER, send the goods to:

Pelco c/o Expeditors
473 Eccles Avenue
South San Francisco, CA 94080 USA
Phone: 650-737-1700
Fax: 650-737-0933

REVISION HISTORY

Manual #	Date	Comments
C1997M	3/01	Original version.

Pelco, the Pelco logo, Camclosure, Esprit, Genex, Legacy, and Spectra are registered trademarks of Pelco. Endura and ExSite are trademarks of Pelco.

©Copyright 2001, Pelco.
All rights reserved.

Free Manuals Download Website

<http://myh66.com>

<http://usermanuals.us>

<http://www.somanuals.com>

<http://www.4manuals.cc>

<http://www.manual-lib.com>

<http://www.404manual.com>

<http://www.luxmanual.com>

<http://aubethermostatmanual.com>

Golf course search by state

<http://golfingnear.com>

Email search by domain

<http://emailbydomain.com>

Auto manuals search

<http://auto.somanuals.com>

TV manuals search

<http://tv.somanuals.com>