

# GLACIER

## Cycling Refrigerated Compressed Air Dryers with “Zero-Loss” Drain Trap

### Operation & Maintenance Manual

### MODELS G5C 0018 thru G5C 0250

#### - TABLE OF CONTENTS -

<b>1.0</b>	<b>GENERAL</b>	<b>2</b>
1.1	How to use this manual	
1.2	Symbols	
1.3	Warranty	
1.4	Standard Equipment	
1.5	Description of Operation	
1.6	Use	
1.7	General Safety Instructions	
<b>2.0</b>	<b>MACHINE UNPACKING AND HANDLING</b>	<b>3</b>
2.1	Unpacking and handling	
2.2	Package disposal	
2.3	Returned Equipment	
<b>3.0</b>	<b>SET-UP</b>	<b>4</b>
3.1	Positioning	
3.2	Installation	
3.3	Filling the thermal mass reservoir	
3.4	Start-Up	
3.5	Dryer Transportation or Long-Term Storage	
<b>4.0</b>	<b>MAINTENANCE</b>	<b>5</b>
4.1	Weekly	
4.2	Monthly	
4.3	Semi-annually	
<b>5.0</b>	<b>EQUIPMENT DATA</b>	<b>5</b>
<b>6.0</b>	<b>CONTROL PANEL OPERATION</b>	<b>6</b>
6.1	Status LEDs	
6.2	Button Functions	
6.3	Set Point Modification	
6.4	Digital Display	
6.5	Error Codes	
<b>7.0</b>	<b>TROUBLESHOOTING</b>	<b>7</b>
<b>8.0</b>	<b>INTELLIDRAIN</b>	<b>8</b>
8.1	Operation	
8.2	Controls	
8.3	Maintenance	
<b>9.0</b>	<b>DIMENSIONAL DATA</b>	<b>9</b>
<b>10.0</b>	<b>REFRIGERATION CIRCUIT DIAGRAMS</b>	<b>10</b>
<b>11.0</b>	<b>ELECTRICAL WIRING DIAGRAMS</b>	<b>10</b>
<b>12.0</b>	<b>SYSTEM INSTALLATION &amp; LAYOUT</b>	<b>13</b>

## 1.0 GENERAL

### 1.1 How to use this manual

All features of this machine, including information on safety, installation, operation, and maintenance are described in this manual. This manual is an integral part of the machine and must be read and understood by any person involved with its operation or maintenance. In the event of re-sale of this unit, this manual should be forwarded to the new owner. Replacement manuals may be obtained from your authorized dealer.

### 1.2 Symbols

The symbols below are used throughout this manual, and on the unit itself, to indicate specific unit components or potential safety hazards that will be encountered during machine operation and maintenance.



Air inlet



Condensate drain outlet



Air outlet



Direction of rotation of fan motor



Electric shock danger!

### 1.3 Warranty

This product has been factory tested before shipment. It is guaranteed to be free from defects in material and/or workmanship for a period of 12 months from the date of shipment. This warranty applies provided the machine has been installed and used in accordance with the instructions detailed in this manual. The manufacturer agrees, at its discretion, to repair or replace all defective parts free of charge. Further, the manufacturer agrees to cover charges associated with field labor required to make authorized warranty repairs, provided the PSB-General Air warranty policy is followed and an S.I.R. authorization is issued by PSB-General Air. Labor coverage shall be limited to maximum rates as published in the latest price list. Field repairs may only be performed by a factory authorized service technician. This warranty is limited to defects associated with operation and manufacture only. All parts subject to wear due to their normal operation are not covered by this warranty. All transportation costs associated with factory repair of equipment are the sole responsibility of the owner.

### 1.4 Standard Equipment

- Refrigerated air drying circuit with economizing heat exchanger & condensate separator.
- Automatic condensate drain system.
- Microprocessor-based control panel with LED display and pushbutton user interface.
- Instruction and maintenance manual with wiring diagram.

### 1.5 Description Of Operation

These dryers have been specially designed to provide dry compressed air, while consuming electrical power in direct proportion to the actual load, thereby saving energy. The dryers utilize mechanical refrigeration, in conjunction with thermal storage, to condense moisture by lowering the compressed air temperature to about 37°F. The dryer "stores" its refrigeration ability during periods of low load by making ice. This allows simple and efficient "on/off" control of the refrigerant compressor to be used for capacity control. An air-to-air economizer is employed to minimize the size of the refrigeration plant and to save electrical energy. Condensed moisture is accumulated in the built-in moisture separator and is discharged through the zero air-loss drain. When the dryer is started it is automatically in the direct expansion mode and cools the compressed air by direct heat exchange with refrigerant. When the sensor temperature drops below setpoint (indicating that the dryer capacity is in excess of the load), the refrigerant solenoid valve is closed, forcing refrigerant through the ice-making circuit only. The dryer continues to run, making ice, for a predetermined time interval after which the refrigerant compressor is switched off. At this time, the LED displays the code "ICE" indicating that the dryer is cooling the compressed air by melting the ice-mass. When the sensor temperature rises sufficiently, indicating that the ice-mass has been depleted, the refrigeration system is re-started and the control cycle is repeated.

**ATTENTION: although this dryer is equipped with an on/off switch & internal individual component protection, complete unit over-current & short circuit protection MUST be provided by the installer, in the user's power supply, before the dryer.**

## 1.6 Use

The use of a dryer is recommended for nearly all compressed air applications, but especially when high purity and low moisture content is required, such as in the pharmaceutical & food industry, medical applications and for coating & painting applications.

## 1.7 General Safety Instructions

Read this manual carefully before performing any operation. This machine has been designed and manufactured to be used only as described below. The supplier is not responsible for difficulties associated with operation other than the intended use or operation that is not in compliance with the instructions mentioned in this manual. All maintenance or cleaning operations involving interior parts must be performed by trained technicians only.

### **ALWAYS:**

- **Always** be familiar with all controls.
- **Always** be sure that the dryer is isolated from the compressed air network (inlet and outlet valves closed) and that internal pressure has been released before performing any maintenance.
- **Always** disconnect electrical power and allow 15 minutes for the inner parts to cool down before removing the protection panels.
- **Always** be sure to disconnect electrical power before removing the cooling fan protection grill.
- **Always** be sure that all protection panels are properly attached during operation and after any maintenance operation.

### **NEVER:**

- **Never** place flammable objects near the dryer.
- **Never** use the dryer if the power cable is faulty or the connection is not safe.
- **Never** allow anyone to operate the dryer without giving him/her proper instructions.
- **Never** make any alterations to safety parts.
- **Never** strike or use excessive force on internal parts.
- **Never** touch any part of the cooling circuit when the machine is running. They are very hot!
- **Never** drain the condensate directly into the sewage system... **request PSB-General Air oil/water separator information**

***All installation, use and maintenance operations must be performed according to the instructions detailed in this manual. All dryer maintenance should only be performed by qualified personnel taking the proper safety precautions.***

## 2.0 MACHINE UNPACKING AND HANDLING

### 2.1 Unpacking and Handling

The dryer is shipped on a wooden skid and packaged in a protective cardboard carton with banding straps. The package must always be lifted from the bottom and must be kept in an upright position at all times. Unpack the dryer by cutting straps (always wear safety gloves and eye protection and cut either with scissors or cutting nippers), removing the carton from the top and moving the dryer from the wooden pallet to the chosen position.

### 2.2 Package Disposal

It is recommended that the packaging materials be retained at least throughout the warranty period. Should the dryer need to be transported for service, the original packaging will allow for easier and safer shipping.

### 2.3 Returned Equipment

- Repack the dryer in its original carton or with one of the same dimensions.
- The dryer must be kept vertical and packed as supplied from the manufacturer.
- Do not transport the dryer without proper packing, shipment damage remains the responsibility of the sender.

***Materials returned without proper packing and authorization documents will not be accepted.***

### 3.0 SET-UP

#### 3.1 Positioning

The dryer should be located in an area with a flat floor and protection against weather conditions and, if possible, direct sun light. The area must also be properly ventilated (& heated, if necessary) so that the temperature is kept between **40 °F** and **110 °F** when the dryer is running (remember that the operating dryer will add heat to the room). It must also be large enough to allow at least three feet of free space adjacent to both the condenser air inlet and outlet grills to allow for proper unit cooling.

#### 3.2 Installation

- Air by-pass piping is recommended to allow uninterrupted air service during instances of maintenance or repair.
- Prior to installation check to insure that the compressed air piping is free of debris or other contaminants.
- Connect the dryer to the compressed air line in accordance with one of the diagrams shown in section 11 and per unit labeling.
- Always use a back-up wrench to prevent damage to the connections during piping of the air inlet and outlet.
- Make sure that line power agrees with the unit data plate and the service complies with local electrical codes.
- Always include a fused safety switch in the line power supply (refer to data plate amperage for proper selection).
- A particulate filter is recommended at the air inlet to avoid any deposit of solid particles into the dryer.
- Position the dryer so that all controls can be easily read and so that all maintenance operations are easily performed.
- Connect the condensate drain tube in compliance with local regulations. The condensate is a pollutant and cannot be drained directly into the sewage system. A Motivair oil/water separator of suitable capacity is recommended.

#### 3.3 Filling The Thermal Mass Reservoir

- Remove the threaded plug (A) from the fill port located on the top panel of the dryer.
- Slowly fill the reservoir with clean, tap water until it can be seen coming from the flexible overflow tube (B) at the rear of the dryer.
- Replace the fill port plug.

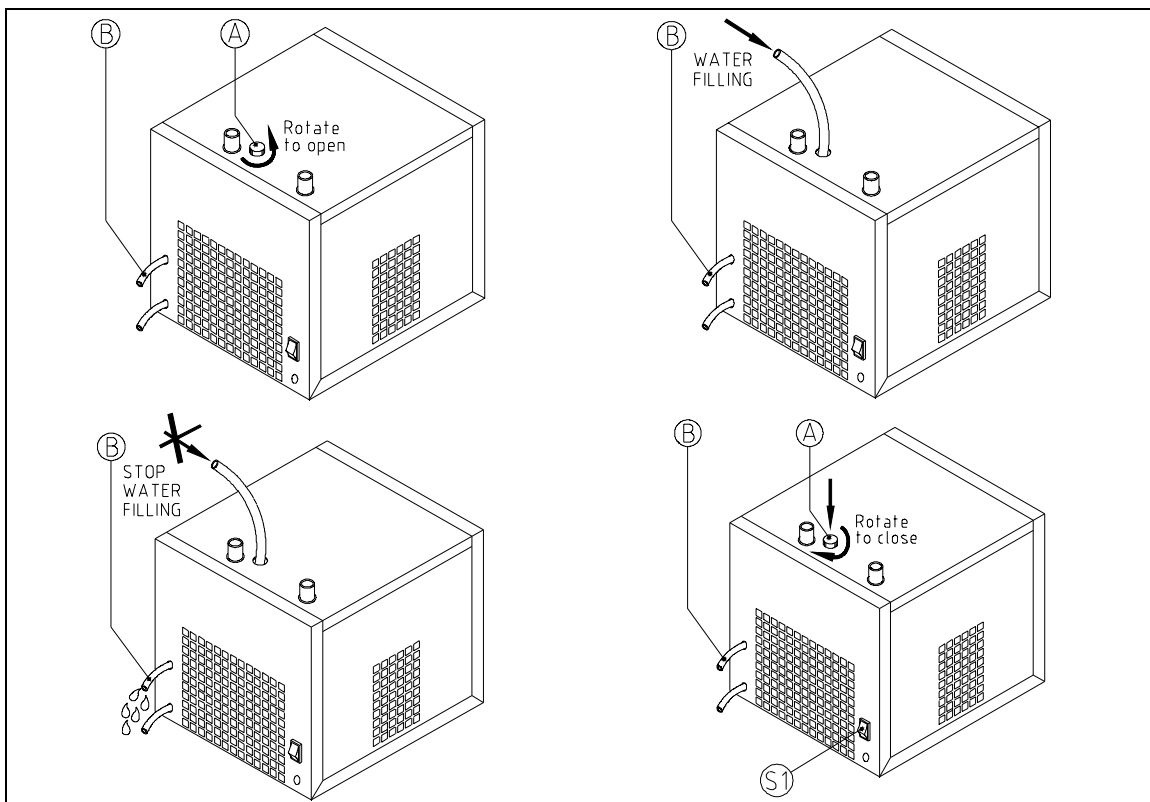

#### 3.4 Start-Up

- Close inlet and outlet valves, switch on **S1** and **ON/OFF (hold for 3 seconds)**, and check for the pilot light on the control panel.
- Allow the dryer to run until the word **“ICE”** appears in the digital display (usually about 15 minutes).
- Open the outlet air valve completely and then gradually pressurize the dryer by slowly opening the inlet air valve.
- Compressed air flow rates in excess of rating will reduce performance but will not compromise safety.

### 3.5 Dryer Transportation or Long-Term Storage

- Close inlet and outlet valves, switch off the devices (S1) and (ON/OFF), and disconnect power.
- Depressurize the air circuit using the condensate trap TEST button & remove the fill port plug to vent the reservoir.
- Drain the reservoir tank into a suitably sized container by removing right side panel (B) & turning drain valve (A) counter-clockwise.
- Replace the fill port plug & close the drain valve (A) by turning clockwise.

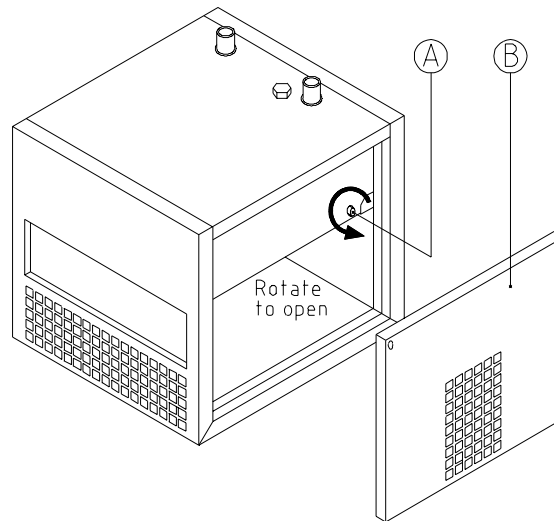

## 4.0 MAINTENANCE

### 4.1 Weekly

- Visually inspect for proper condensate drain operation.

### 4.2 Monthly

- Isolate the dryer from the compressed air system by closing inlet & outlet valves and release pressure.
- Clean or replace condensate drain trap filter to remove any accumulated debris.

### 4.3 Semi-annually

- Check compressor electrical current draw against amperage listed on the data plate.
- Remove power from the dryer and clean condenser finned surfaces with compressed air jet.

## 5.0 EQUIPMENT DATA

Model	G5C-18	G5C-30	G5C-50	G5C-75	G5C-100	G5C-120	G5C-150	G5C-200	G5C-250	G5C-250
Capacity (scfm)*	18	30	60	75	100	120	150	200	250	250
Compressor Power (HP)	1/6	1/4	1/3	1/2	3/4	1	1-1/2	1-1/2	2	2
Power Supply (V/Ph/Hz)	115/1/60	115/1/60	115/1/60	115/1/60	115/1/60	115/1/60	230/1/60	230/1/60	230/1/60	460/3/60
Rated Current (A)	1.1	3.7	5.2	6.8	8.1	9.2	7.5	7.5	8.5	3
Full Load Current (A)	2	4.6	6.8	8	9.8	11	8.7	10.5	12.5	5.2
Refrigerant Type	R-134a	R-134a	R-134a	R-134a	R-134a	R-134a	R-134a	R-134a	R-134a	R-134a
Refrigerant Charge (LBS)	0.66	0.79	1.21	1.21	1.21	1.32	1.75	2.16	2.0	2.0
Connection Size F (NPT)	1/2	1/2	3/4	3/4	3/4	1-1/2	1-1/2	1-1/2	1-1/2	1-1/2
Weight (lbs)	66	77	119	132	141	203	232	232	247	247
Max. Air Inlet (°F)	113	113	113	113	113	113	113	113	113	113
Max. Ambient (°F)	104	104	104	104	104	104	104	104	104	104
Max. Pressure (psig)	230	230	230	230	230	230	230	230	230	230

\*Rated capacity @ air inlet of 100°F & 100 psig, 100°F ambient & 33 – 39° F leaving dewpoint



**6.0 CONTROL PANEL OPERATION**

These dryers are equipped with an electronic controller. *Please note that the SET POINT & other control parameters have been optimized and factory set. Although the set point value can be displayed, the ability to alter these factory settings via the digital interface on the front panel has been removed to eliminate the possibility of unit damage caused by improper settings.* A description of the operation of the digital interface is provided below however, to facilitate *factory-authorized* adjustments.

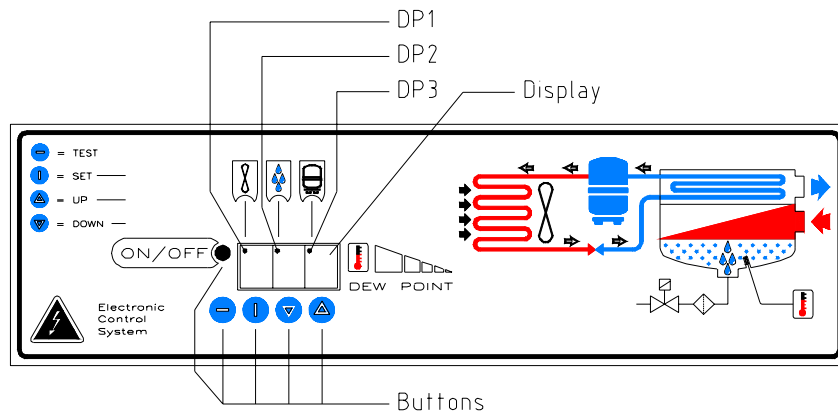

**6.1 Status LEDs**

<b>DP1</b>	On	DX solenoid energized
<b>DP2</b>	On	Condensate drain valve energized
<b>DP3</b>	On	Compressor energized

**6.2 Button Functions**

<b>TEST</b>	<ul style="list-style-type: none"> <li>Performs a test of the condensate discharge valve when pressed for more than 3 seconds during the normal operation.</li> </ul>
<b>SET</b>	<ul style="list-style-type: none"> <li>Displays the set point value when pressed during normal operation.</li> <li>Stores all changes when pressed after changing set point.</li> </ul>
<b>DOWN</b>	<ul style="list-style-type: none"> <li>Decreases the displayed value when pressed during set point programming (<i>see factory</i>).</li> </ul>
<b>UP</b>	<ul style="list-style-type: none"> <li>Increases the displayed value when pressed during set point programming (<i>see factory</i>).</li> </ul>
<b>ON/OFF</b>	<ul style="list-style-type: none"> <li>Activates or deactivates unit operation <b>when pressed for 3 seconds</b>. When deactivated, the OFF message is displayed.</li> </ul>

**6.3 Set Point Modification**

- Press the SET button (the current set point value is displayed).
- Modify (*see factory*) the displayed set point value by using the UP or DOWN button (if modification is not performed in 15 seconds the controller automatically returns to the normal operating display indicating the DEW POINT value).
- Confirm the new set value by pushing the SET button within 10 seconds of the modification, the flashing of the set point value confirms acceptance of the new data. *If the modified data is not confirmed within 10 seconds, the new data will not be stored and the controller will revert to the previous set point.*

**Please note that changes to the set point WILL adversely effect dryer operation and therefore should only be done by authorized technical service personnel.**

**6.4 Digital Display**

Message (NOT flashing)	Description
Numeric Value	Dewpoint Temperature
"ICE"	Energy Saving Standby Mode

**6.5 Error Codes**

The controller recognizes specific types of operational errors. When an error occurs the display shows a flashing alarm message alternating with the current dewpoint value, as described below:

Message (flashing)	Cause
HtA	High Dewpoint Temperature
PF1	Temperature Sensor failure

All the alarms except for PF1 are automatically reset when the cause is removed. PF1 must be cleared by switching the unit off and then re-started. PF1 has a priority over all the other displayed messages.

**7.0 TROUBLESHOOTING**

SYMPTOM	POSSIBLE ORIGIN	SOLUTION
Temperature shown in display is higher than preset value	High compressed air inlet temperature	Reduce air temperature to within design limits
	High compressed air flow	Reduce air flow to within design limits
	High ambient air temperature	Increase ventilation rate of installation area
	Fouled refrigerant condenser	Clean condenser
	Low refrigerant charge	Locate & repair leak & re-charge
	Faulty refrigerant compressor	Repair or replace
	Faulty refrigerant solenoid valve	Repair or replace
	Faulty fan thermostat	Repair or replace
	Faulty control relay	Repair or replace
Excessive air pressure drop across dryer	Refrigerant high pressure switch open	Eliminate cause & reset switch
	Inlet/outlet piping reversed	Connect properly
	Thermostat sensor out of well	Re-install
	Faulty thermostat	Repair or replace
	Ambient temperature below freezing	Install dryer in heated space
Water present in air downstream of dryer	Obstruction in air circuit	Locate & remove blockage
	Air by-pass valve open	Close valve
	Condensate drain strainer fouled	Clean strainer
	Faulty condensate drain	Repair or replace
	High dew point temperature	See Symptom #1 above



Fan doesn't start and/or stop.	Faulty fan thermostat or pressostat	Repair or replace
	Low refrigerant charge	Locate & repair leak & re-charge
	Low load with low ambient temprature	Install dryer in heated space

## 8.0 ZERO-LOSS DRAIN TRAP

### 8.1 Operation

- The Zero-loss drain is designed to remove condensate from any compressed air application without air loss. It is completely automatic, and requires no external settings or adjustments.
- A two-stage condensate level sensor installed in the trap's internal cavity signals both the beginning and the end of the discharge cycle so the trap discharges only liquid and no air is wasted regardless of load.
- At start-up, purge any air from the trap's inlet connection by pushing the TEST button several times.
- The factory-installed inlet filter should be examined and cleaned daily for the first week of operation, and monthly thereafter.

### 8.2 Controls

- Green LED: Electrical Power ON
- Red LED: Discharge Solenoid Energized (valve open)
- Pushbutton: Discharge TEST (Open Valve Manually)

### 8.3 Maintenance

- Close the ball valve located on the filter/stop installed at the drain trap inlet.
- Depressurize the trap by pushing the TEST button.
- Unscrew the plug in the end of the filter/stop to access the filter screen.
- Clean the filter screen with a compressed air jet.
- Reassemble and open filter/stop valve.

TEST button



**9.0 DIMENSIONAL DATA**

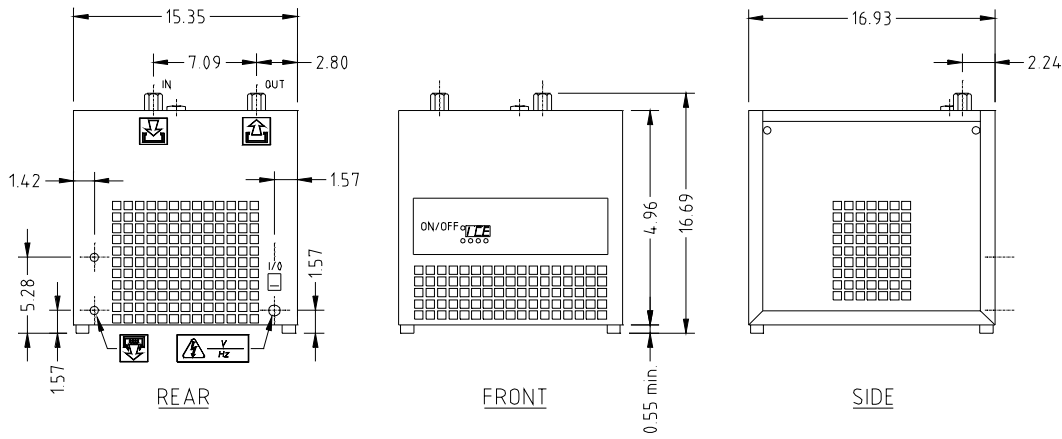

**MODEL G5C 18 THRU 30**

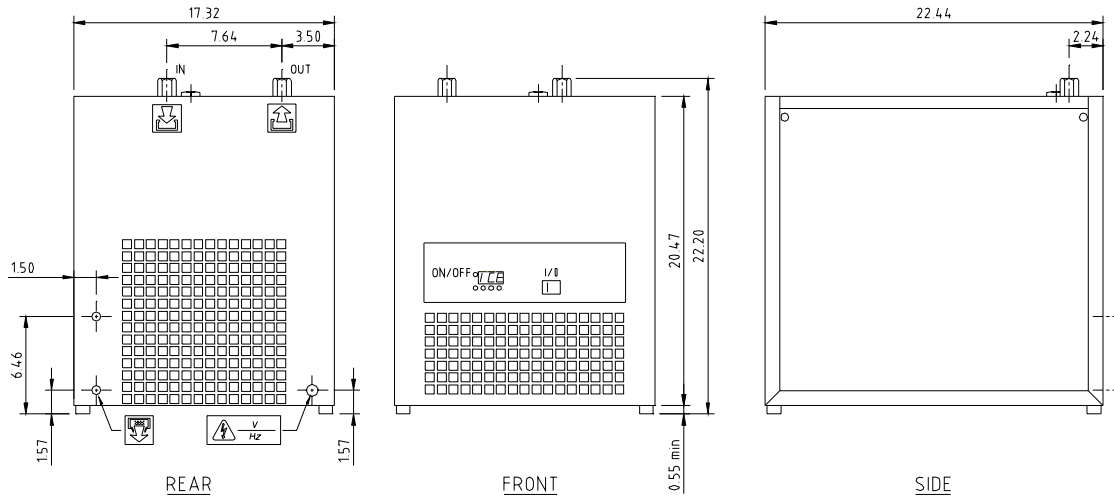

**MODEL G5C 50 THRU 100**

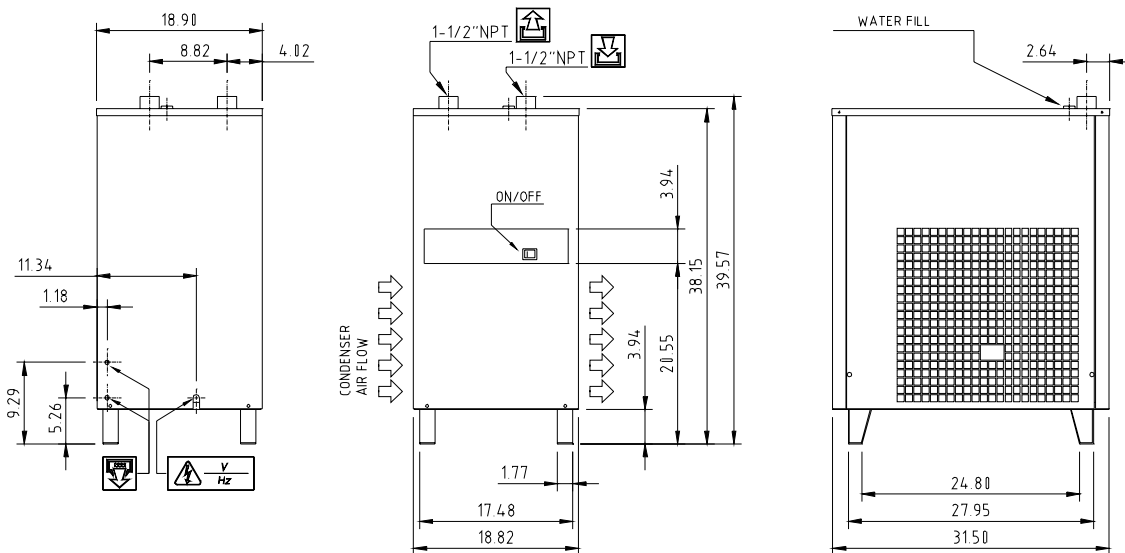

**MODEL G5C 120 THRU 250**

**10.0 REFRIGERATION CIRCUIT DIAGRAMS**

1	Compressor	8	Refrigerant Filter/Dryer
2	Condenser	9	DX Solenoid Valve
3	Fan	10	Fan Pressure Switch
4	Air-to-Air Economizer	11	Refrig. High Pressure Switch
5	Evaporator	12	Condensate Separator
6	Zero-Loss Drain Valve	13	Condensate strainer & Shut-Off
7	Capillary Tubes		

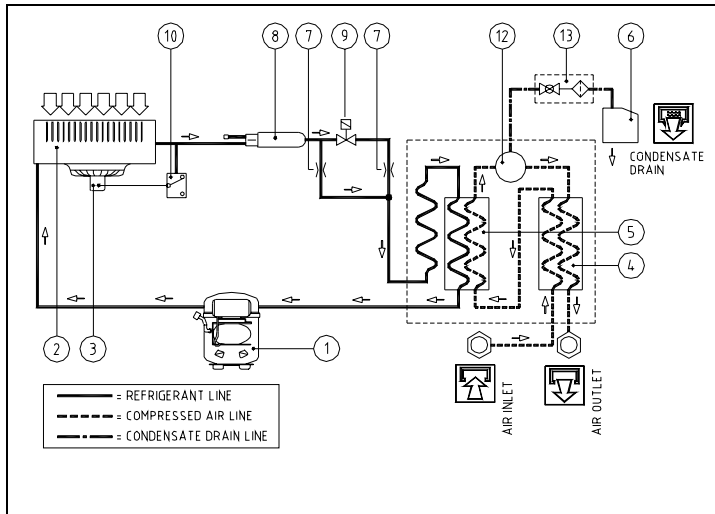

G5C 18 THRU 75 Cod. 713.001.04.00 – Rev. 01 – 28.09.00

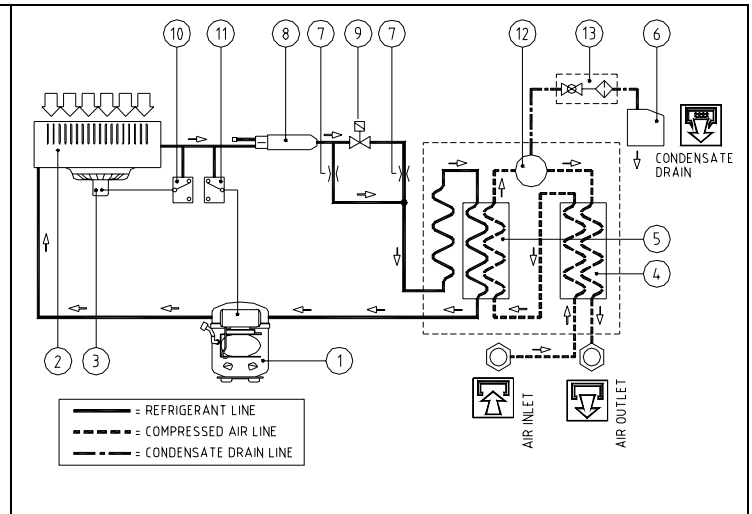

G5C 100 THRU 250 Cod. 713.001.01.00 – Rev. 01 – 28.09.00

**11.0 ELECTRICAL WIRING DIAGRAMS**

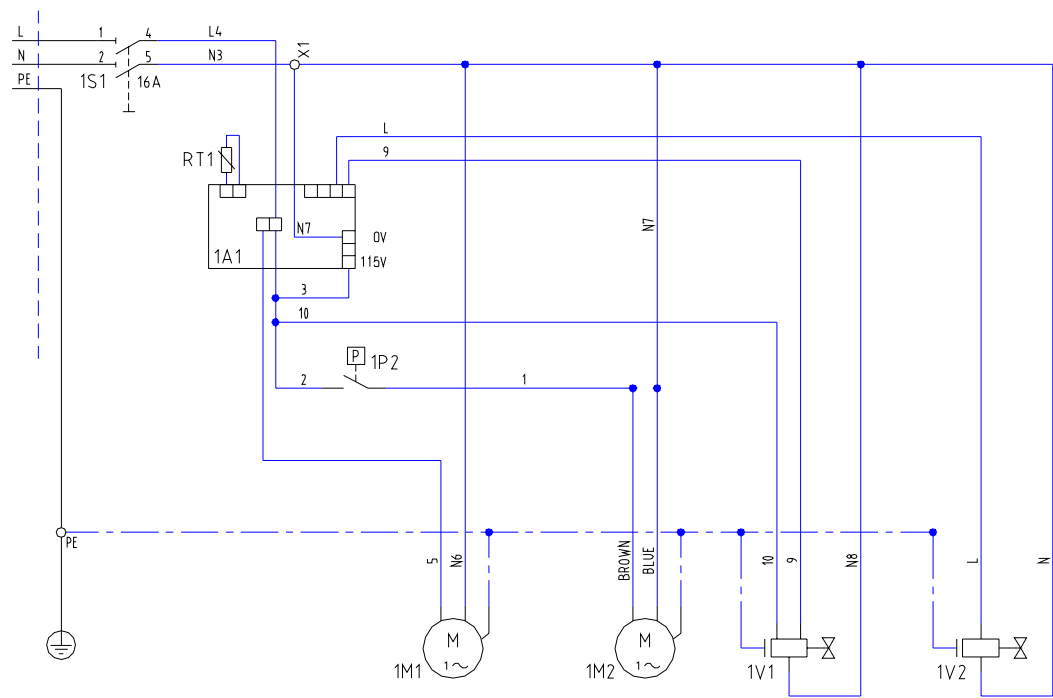

1M1	COMPRESSORE FRIGORIFERO REFRIGERANT COMPRESSOR
1M2	VENTILATORE CONDENSATORE FRIGORIFERO REFRIGERANT CONDENSER FAN
1V1	ELETTROVALVOLA DI SCARICO CONDENSA CONDENSATE DRAIN SOLENOID VALVE
1V2	ELETTROVALVOLA CIRCUITO FRIGORIFERO REFRIGERANT SOLENOID VALVE
1P2	PRESSOSTATO VENTILATORE FAN PRESSURE SWITCH
1S1	INTERRUTTORE SEZIONATORE MAIN SWITCH
1A1	CONTROLLORE ELETTRONICO ELECTRONIC CONTROLLER
RT1	SONDA TEMPERATURA TEMPERATURE PROBE
X1	MORSETTO TERMINAL BLOCK

G5C 18 THRU 75 (115/1/60) Cod. 714.001.02.00

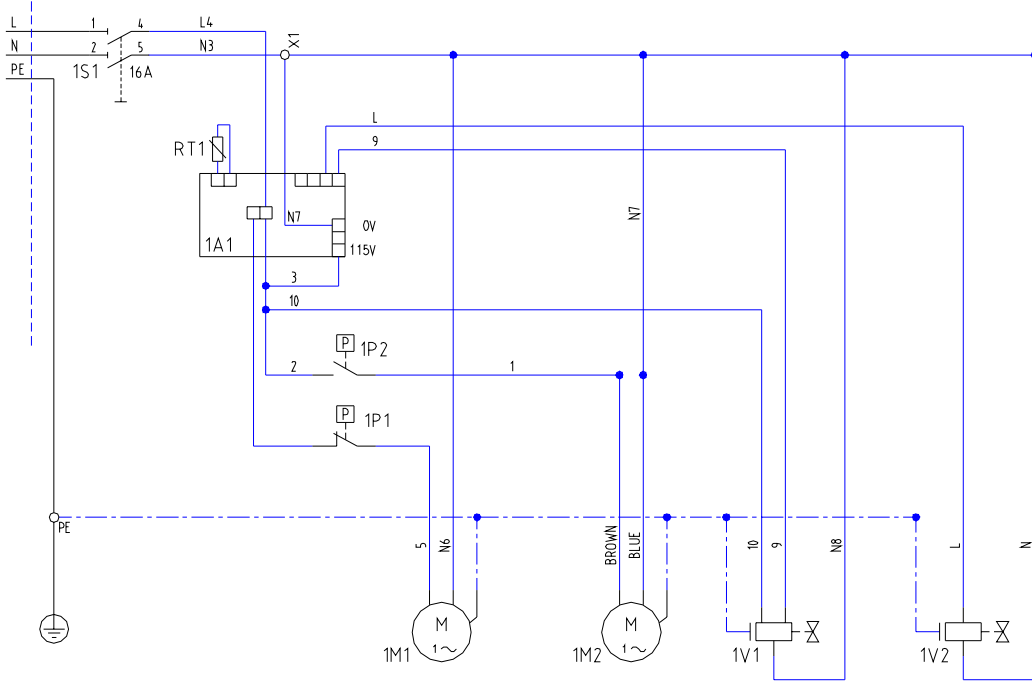

1M1	COMPRESSORE FRIGORIFERO REFRIGERANT COMPRESSOR
1M2	VENTILATORE CONDENSATORE FRIGORIFERO REFRIGERANT CONDENSER FAN
1V1	ELETTROVALVOLA DI SCARICO CONDENSA CONDENSATE DRAIN SOLENOID VALVE
1V2	ELETTROVALVOLA CIRCUITO FRIGORIFERO REFRIGERANT SOLENOID VALVE
1P1	PRESSOSTATO DI SICUREZZA HIGH PRESSURE SAFETY SWITCH
1P2	PRESSOSTATO VENTILATORE FAN PRESSURE SWITCH
1S1	INTERRUTTORE SEZIONATORE MAIN SWITCH
1A1	CONTROLLORE ELETTRONICO ELECTRONIC CONTROLLER
RT1	SONDA TEMPERATURA TEMPERATURE PROBE
X1	MORSETTO TERMINAL BLOCK

**G5C 100 (115/1/60) Cod. 714.001.01.00**

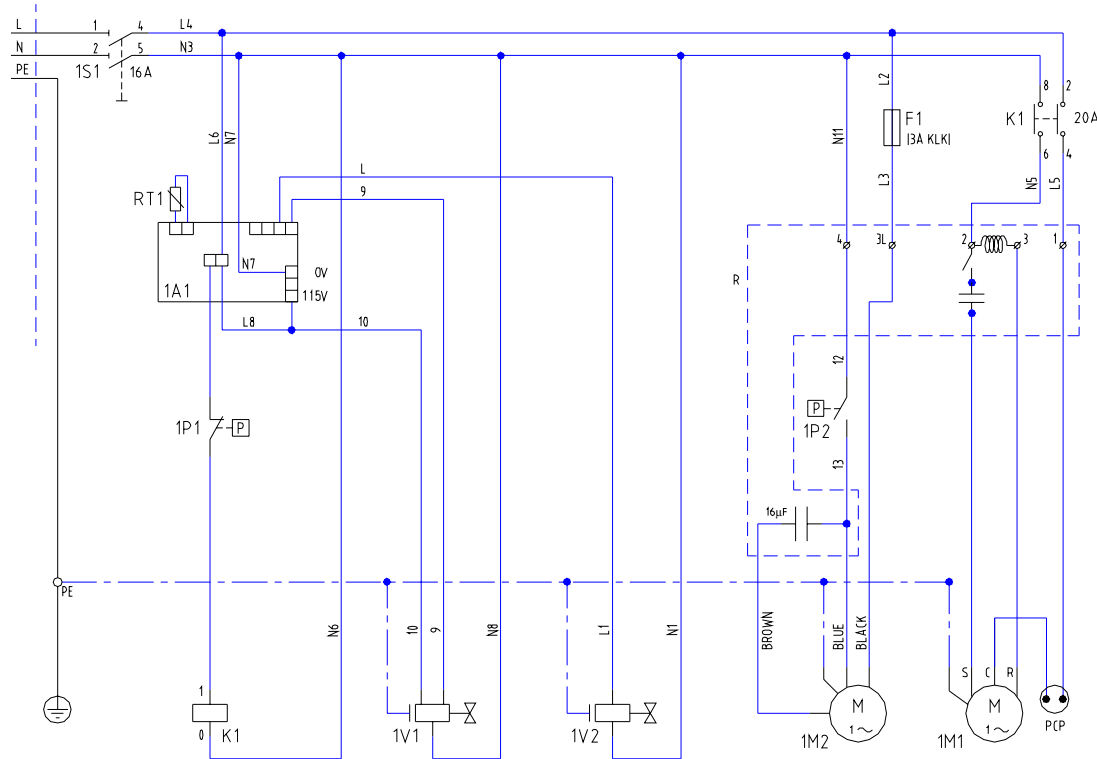

1M1	COMPRESSORE FRIGORIFERO REFRIGERANT COMPRESSOR
1M2	VENTILATORE CONDENSATORE FRIGORIFERO REFRIGERANT CONDENSER FAN
1V1	ELETTROVALVOLA DI SCARICO CONDENSA CONDENSATE DRAIN SOLENOID VALVE
1V2	ELETTROVALVOLA CIRCUITO FRIGORIFERO REFRIGERANT SOLENOID VALVE
1P1	PRESSOSTATO DI SICUREZZA HIGH PRESSURE SAFETY SWITCH
1P2	PRESSOSTATO VENTILATORE FAN PRESSURE SWITCH
1S1	INTERRUTTORE SEZIONATORE MAIN SWITCH
1A1	CONTROLLORE ELETTRONICO ELECTRONIC CONTROLLER
RT1	SONDA TEMPERATURA TEMPERATURE PROBE
K1	CONTATTORE CONTACTOR SWITCH
F1	FUSIBILE VENTILATORE FAN FUSING
R	BOX COMPRESSORE COMPRESSOR BOX

**G5C 120 (115/1/60) Cod. 714.003.03.00**

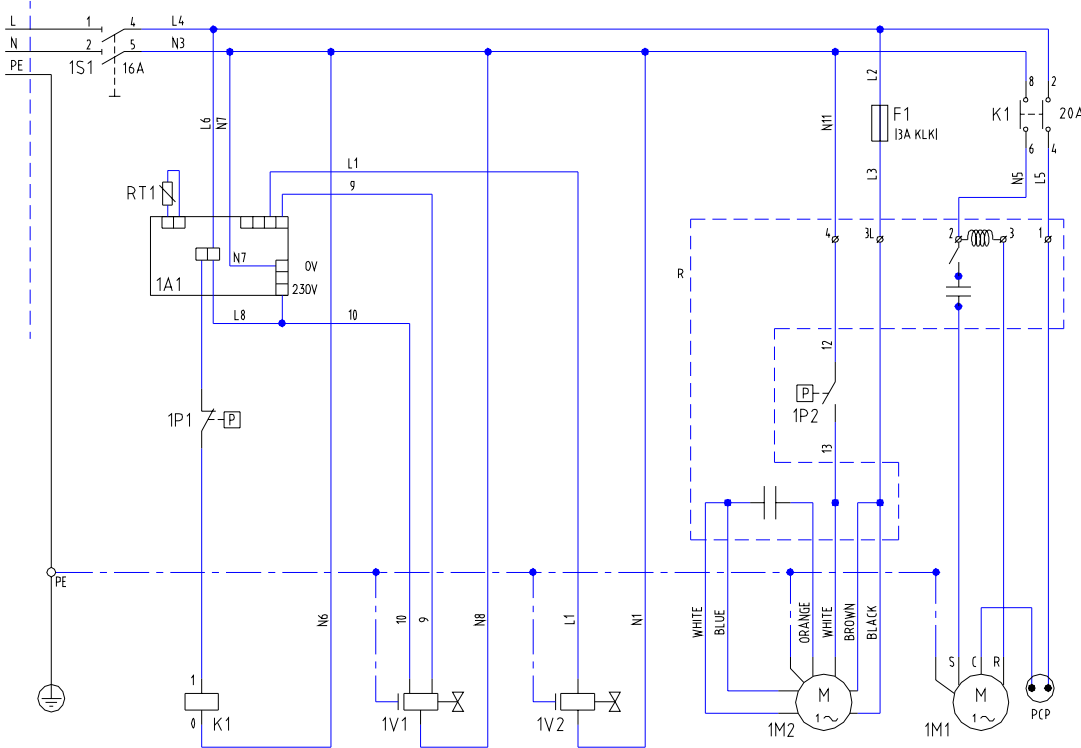

1M1	COMPRESSORE FRIGORIFERO REFRIGERANT COMPRESSOR
1M2	VENTILATORE CONDENSATORE FRIGORIFERO REFRIGERANT CONDENSER FAN
1V1	ELETTROVALVOLA DI SCARICO CONDENSA CONDENSATE DRAIN SOLENOID VALVE
1V2	ELETTROVALVOLA CIRCUITO FRIGORIFERO REFRIGERANT SOLENOID VALVE
1P1	PRESSOSTATO DI SICUREZZA HIGH PRESSURE SAFETY SWITCH
1P2	PRESSOSTATO VENTILATORE FAN PRESSURE SWITCH
1S1	INTERRUTTORE SEZIONATORE MAIN SWITCH
1A1	CONTROLLORE ELETTRONICO ELECTRONIC CONTROLLER
RT1	SONDA TEMPERATURA TEMPERATURE PROBE
K1	CONTATTORE CONTACTOR SWITCH
F1	FUSIBILE VENTILATORE FAN FUSING
R	BOX AVVIAMENTO COMPRESSORE COMPRESSOR BOX

**G5C 150 (230/1/60) Cod. 714.003.01.00 – Rev. 05 –10.01.01**

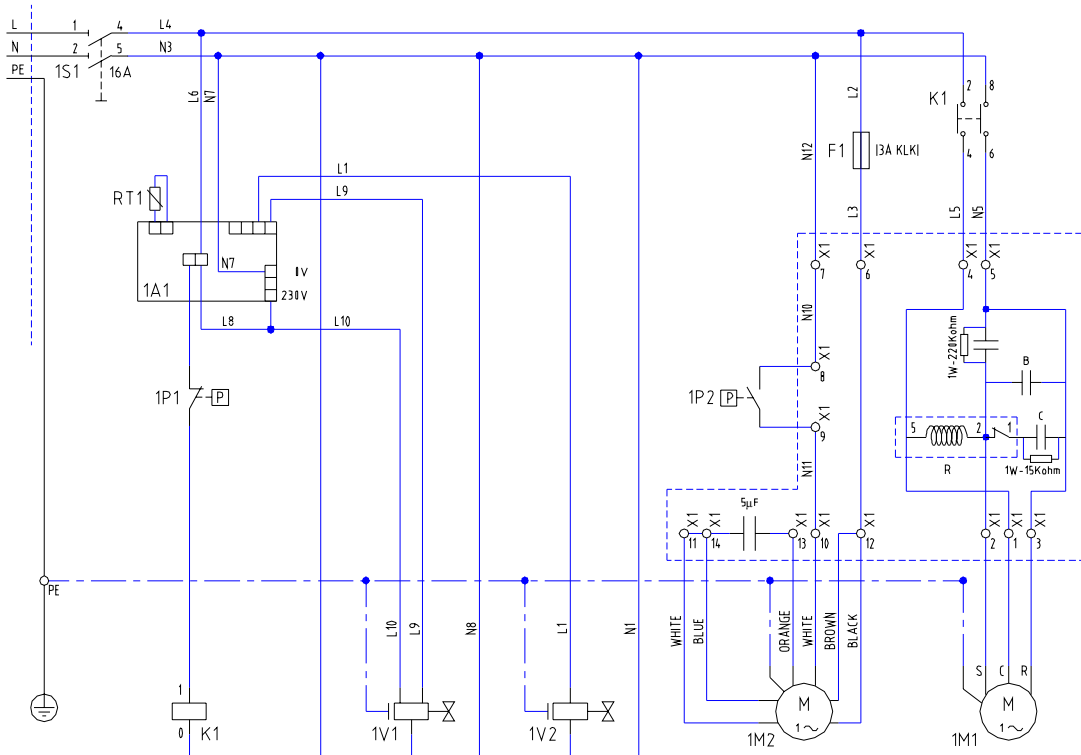

1M1	COMPRESSORE FRIGORIFERO REFRIGERANT COMPRESSOR
1M2	VENTILATORE CONDENSATORE FRIGORIFERO REFRIGERANT CONDENSER FAN
1V1	ELETTROVALVOLA DI SCARICO CONDENSA CONDENSATE DRAIN SOLENOID VALVE
1V2	ELETTROVALVOLA CIRCUITO FRIGORIFERO REFRIGERANT SOLENOID VALVE
1P1	PRESSOSTATO DI SICUREZZA HIGH PRESSURE SAFETY SWITCH
1P2	PRESSOSTATO VENTILATORE FAN PRESSURE SWITCH
1S1	INTERRUTTORE SEZIONATORE MAIN SWITCH
1A1	CONTROLLORE ELETTRONICO ELECTRONIC CONTROLLER
RT1	SONDA TEMPERATURA TEMPERATURE PROBE
K1	CONTATTORE CONTACTOR SWITCH
F1	FUSIBILE VENTILATORE FAN FUSING
X1	MORSETTIERA INTERNO SCATOLA ELETTRICA ELECTRICAL BOX TERMINAL BLOCKS
A - B	CONDENSATORI DI MARCIA RUN CAPACITORS
C	CONDENSATORE DI SPUNTO START CAPACITOR

**ICE 200**

A	= 15µF
B	= 30µF
C	= 100µF

**ICE 250**

A	= 15µF
B	= 25µF
C	= 135µF

**G5C 200 - 250 (230/1/60) ELECTRIC WIRING DIAGRAM - Cod. 714.002.01.00 - Rev. 05 - 29.04.02**

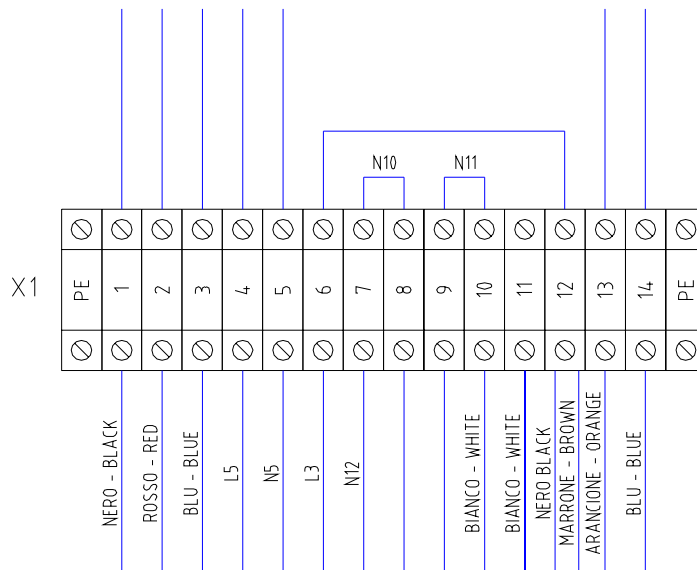

**G5C 200 - 250 (230/1/60) TERMINAL BLOCK DIAGRAM - Cod. 714.002.01.00 - Rev. 05 - 29.04.02**

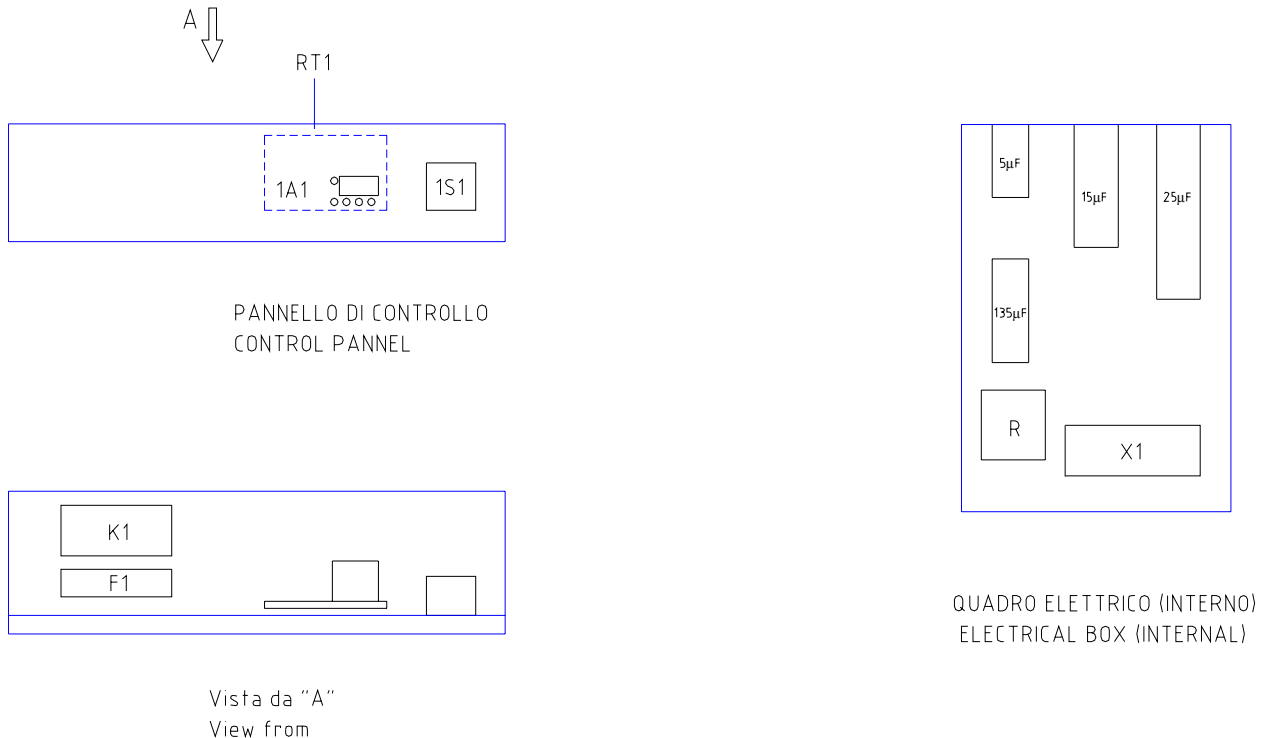

**G5C 200 - 250 (230/1/60) COMPONENTS LAYOUT - Cod. 714.002.01.00 - Rev. 05 - 29.04.02**

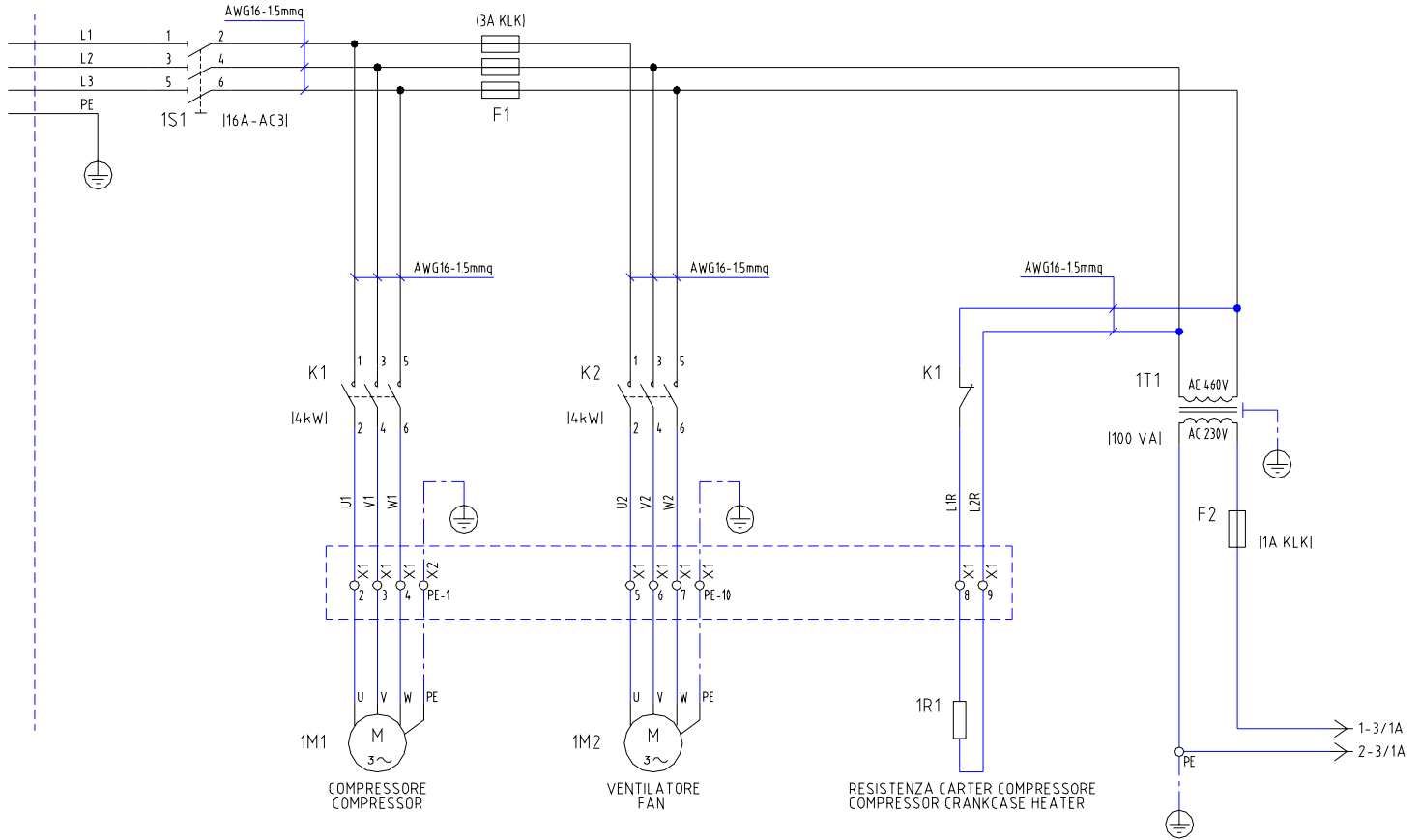

**G5C 250 (460/3/60) POWER WIRING DIAGRAM - Cod. 714.003.02.00 - Rev. 03 - 02.05.02**

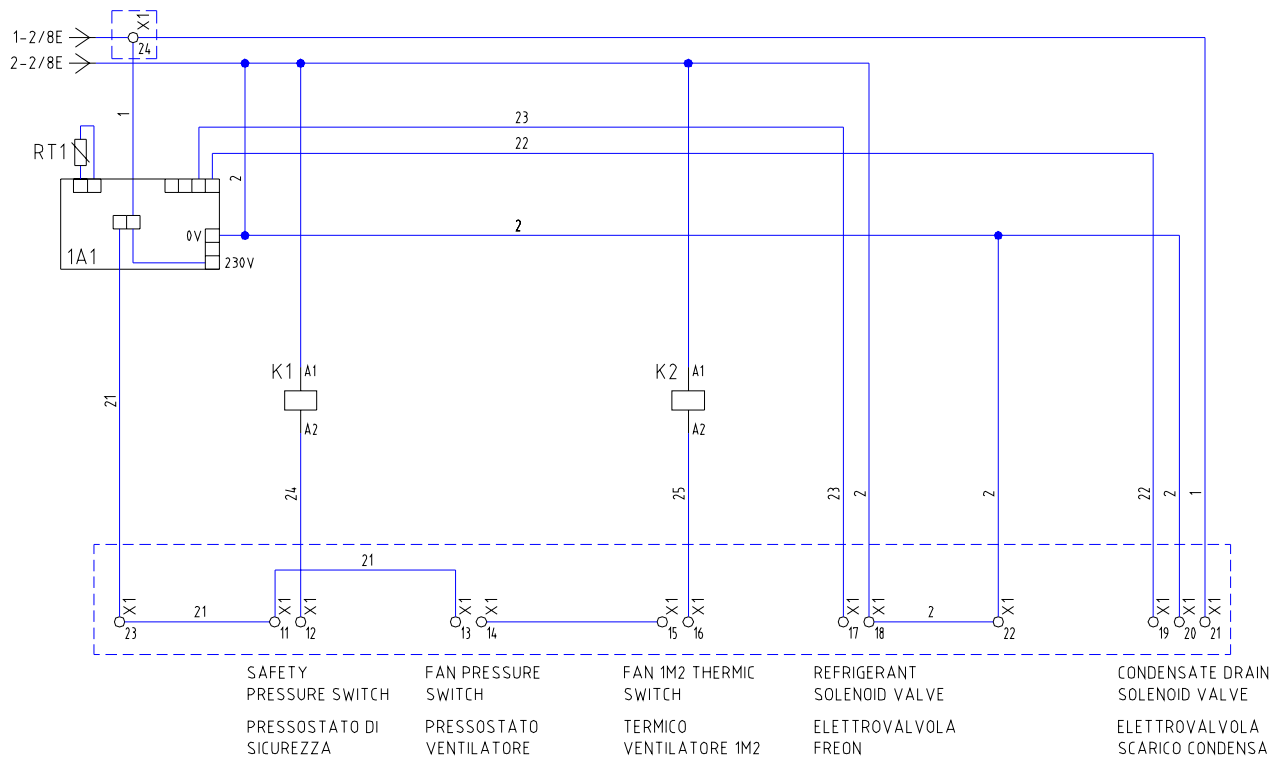

**G5C 250 (460/3/60) CONTROL WIRING DIAGRAM - Cod. 714.003.02.00 - Rev. 03 - 02.05.02**



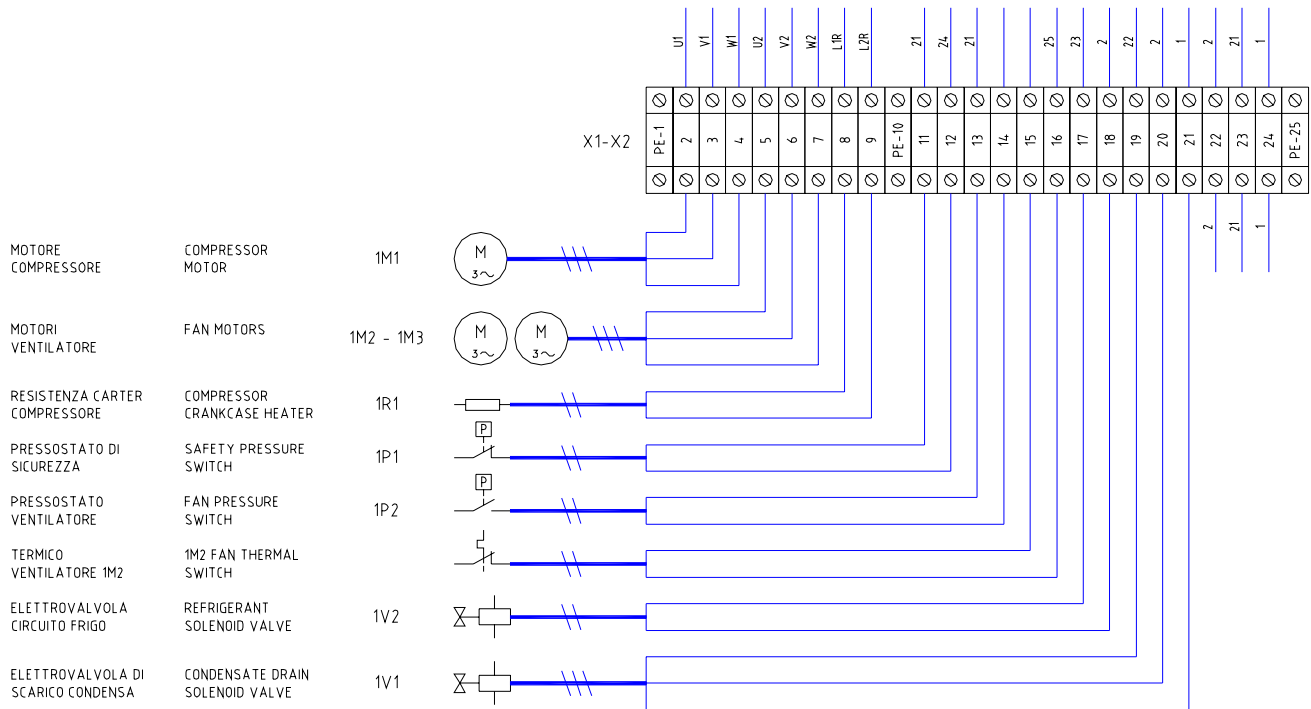

**G5C 250 (460/3/60) TERMINAL BLOCK DIAGRAM - Cod. 714.003.02.00 - Rev. 03 - 02.05.02**

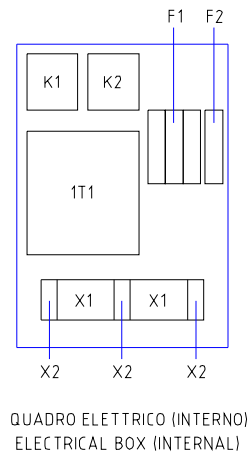
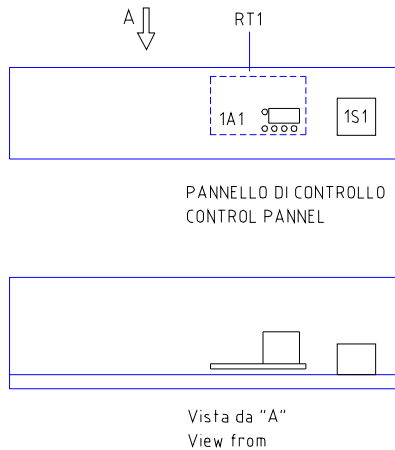

**G5C 250 (460/3/60) COMPONENTS LAYOUT - Cod. 714.003.02.00 - Rev. 03 - 02.05.02**

RIF. REF.	COSTRUTTORE MANUFACTURER	MODELLO MODEL	DENOMINAZIONE	DESCRIPTION
F1 x 3	OMEGA	3A KLK - 10x38 (UL-CSA)	FUSIBILI VENTILATORE E TRASFORMATORE	FAN AND TRANSFORMER FUSES
F2	OMEGA	1A KLK - 10x38 (UL-CSA)	FUSIBILE CIRCUITO CONTROLLO	CONTROL CIRCUIT FUSE
K1	SIEI	SC03/T 240 1NC	CONTATTORE COMPRESSORE	COMPRESSOR CONTACTOR SWITCH
K2	SIEI	SC03/T 240 1NC	CONTATTORE VENTILATORE	FAN CONTACTOR SWITCH
1S1	BRETER	LE2-20-1753	INTERRUTTORE SEZIONATORE	MAIN SWITCH
1T1	ELFRI	100VA 50/60Hz - 460/230V	TRASFORMATORE	TRANSFORMER
X1	WEIDMULLER	WDU 2.5	MORSETTIERA	TERMINAL BLOCKS
X2	WEIDMULLER	WDU 4	MORSETTIERA	TERMINAL BLOCKS
1A1	OMI	305.052.02.00	CONTROLLORI ELETTRONICI	ELECTRONIC CONTROLLERS
RT1	OMI	243.025.03.00	SONDE TEMPERATURA	TEMPERATURE PROBES

**12.0 SYSTEM INSTALLATION & LAYOUT DIAGRAM**

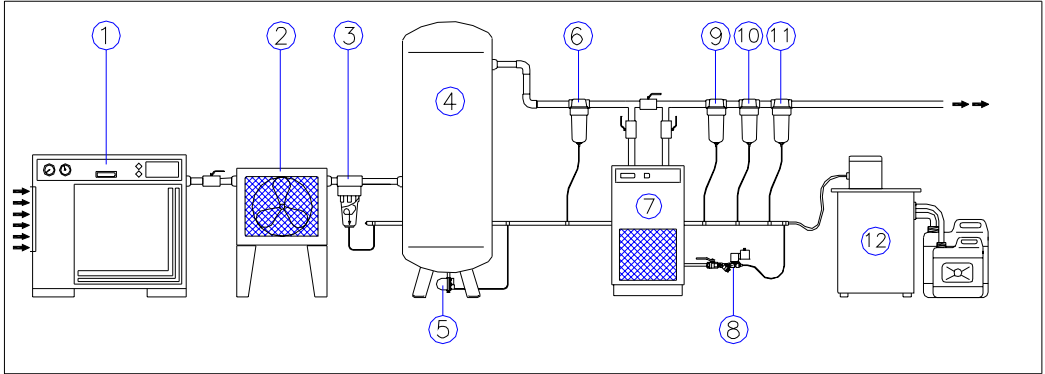

1	Air Compressor
2	Aftercooler
3	Condensate Separator
4	Receiver Tank
5	Automatic Drain
6	Particulate Prefilter
7	Dryer
8	IntelliDrain™
9	Filter 0.10 micron
10	Filter 0.01micron
11	Activated Carbon Filter
12	Water/Oil Separator

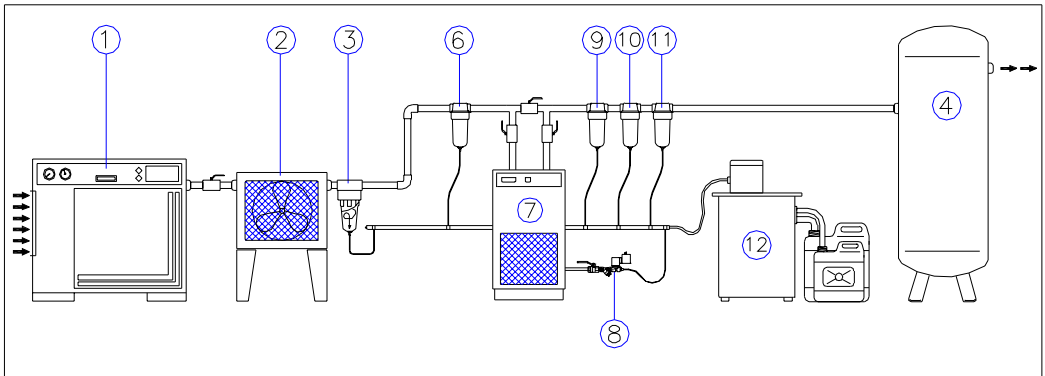

## Free Manuals Download Website

<http://myh66.com>

<http://usermanuals.us>

<http://www.somanuals.com>

<http://www.4manuals.cc>

<http://www.manual-lib.com>

<http://www.404manual.com>

<http://www.luxmanual.com>

<http://aubethermostatmanual.com>

Golf course search by state

<http://golfingnear.com>

Email search by domain

<http://emailbydomain.com>

Auto manuals search

<http://auto.somanuals.com>

TV manuals search

<http://tv.somanuals.com>