

INSTALLATION & MAINTENANCE MANUAL FOR
QuickDraw[®]
INSTANTANEOUS
ENERGY: WATER TO WATER
U-TUBE SINGLE-WALL & DOUBLE-WALL HEAT EXCHANGERS

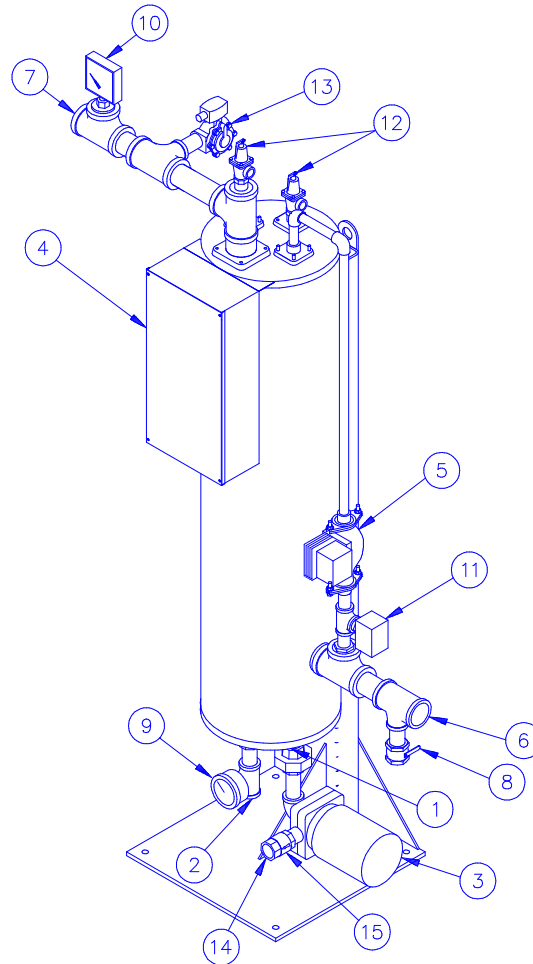

TYPICAL CONSTRUCTION
FIGURE 24-1

- | | |
|--------------------------|-------------------------------------|
| 1. U-tube Heat Exchanger | 9. Boiler Water Temperature Gauge * |
| 2. Boiler Water Inlet | 10. Tridicator * |
| 3. Boiler Water Pump | 11. Flow Switch * |
| 4. Control Enclosure | 12. Relief Valve (AGA optional) |
| 5. Intratank Circulator | 13. Tank Purge Valve * |
| 6. Potable Water Inlet | 14. Boiler Water Outlet |
| 7. Potable Water Outlet | 15. Check Valve |
| 8. Tank Drain | |

* Optional

CAUTION: TEMPERATURES HIGHER THAN 125°F. INCREASE THE RISK OF SCALD INJURY!

IMPORTANT: Clearances for servicing and inspection are 18" at top, sides and rear and a minimum of one tank diameter in front.

WATER WITH SINGLE-WALL / DOUBLE-WALL

START-UP OPERATION

1. The boiler water circulating pump has been selected to provide optimum flow through the heat exchanger tubes to meet demand with the available boiler water. The pump is controlled by the thermostat and draws from the operating boiler water loop. When the demand is satisfied, the pump stops, causing the boiler water to bypass the

unit. In addition, the water heater maybe equipped with a continuous operation tank circulation pump. The boiler water circulation pump is sized to satisfy all of the head resistance of the heat exchanger, therefore no pressure drop need be considered for this unit in sizing primary loop pumps.

CAUTION: Temperatures higher than 125°F. increase the risk of scald injury.

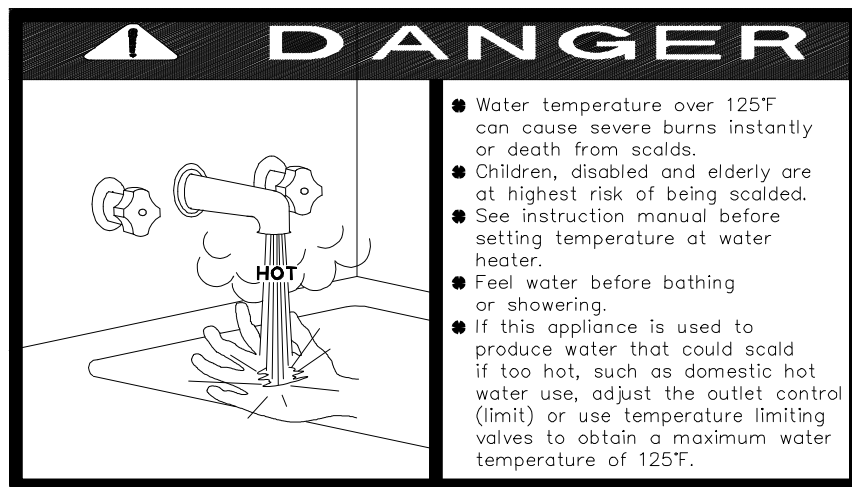

START-UP PROCEDURE

1. Fill the tank with water; open the relief valve or a nearby hot water outlet to purge air from the top of tank. Check for plumbing leaks.
2. Push the control switch to “on” position. Check boiler water pump operation. The tank circulating pump should also operate. Check thermostats for proper setting. The thermostats are labeled as to their function. The temperature limiting device is set at 200°F.

Temperature Setting: The thermostats are set at the factory to 120°F on the operating control. Upon startup, the

factory preset operating temperature is visible on the LED indicator of the digital controller. Adjust the temperature using the appropriate up and down arrow keys on the face of the controller. A slight variance in temperature control may be noticed as the digital control tunes, allow time for the temperature to stabilize.

3. Open nearby hot water tap to maintain a flow of water through the tank when starting up units. Regulate flow of water through the tank to allow the boiler water pump to cycle off and on, and check operation of unit.

QuickDraw[®]

WATER WITH SINGLE-WALL / DOUBLE-WALL (con't)

ELECTRICAL

The heater is wired for 120 volts and must be electrically grounded in accordance with local codes, or in the absence of local codes, with the latest edition of the National Electrical Code ANSI/NFPA. When unit is installed in Canada, it must conform to the CSA C22.1, Canadian Electrical Code, Part 1 and/or local electrical codes.

1. Water must be pumped continuously through the boiler when it is being fired.
2. Do not energize water heater or pumps until tank is full of water. Serious damage may result.
3. All wiring must be in accordance with all local, state, or federal codes.
4. Provide proper overload protection for the system's circulating pumps.

NOTE: Use only copper wire of proper sizing for incoming service. Damage resulting from use of aluminum wiring will be excluded from coverage under the warranty of this unit.

RELIEF VALVE PIPING

The water heater is supplied with a pressure and temperature relief valve, sized in accordance with ASME requirements. Each relief valve should be piped to a

suitable floor drain. No reducing coupling or other restriction can be installed in the discharge line.

MAINTENANCE

1. A preventive maintenance program should be established to assure a long, trouble-free life for the water heater.
2. Scale will normally form in the tank during operation and will accumulate on the bottom of the tank. The scale is formed from the natural chemicals in the water that precipitate out during the heating cycles. Some water supplies contain more of these chemicals than others, and the scale buildup will occur more rapidly. Other factors affecting the scale buildup are the amount of hot water used and the temperature of the water. The more hot water used, the more fresh water containing the scale-forming chemicals is brought into the tank. As the temperature of the water increases, the rate of scale deposited will be increased. The unit should be inspected and cleaned as required by local water conditions.

QuickDraw[®]

WATER WITH SINGLE-WALL / DOUBLE-WALL (con't)

WARNING: Make sure valve is piped to a proper drain per instructions. Scalding injury and/or water damage can occur from either the manual lifting of the lever or the normal operation of valve if it is not piped to a proper drain. Insure that the safety relief valve piping is of the proper material and rating for the temperature and pressure of the system and that it is secured to prevent possible injury. If valve fails to flow water or reseal, consult the factory.

CAUTION: The relief valve is a primary safety device.

3. The temperature limiting device and thermostat sensors that extend into the water in the tank may become coated with scale, depending on the type of water in your area. This coating will affect the accuracy of the sensors and can allow the water temperature to exceed the desired limits. They should be removed from the tank and inspected at intervals. Remove scale if present.

CAUTION: On control systems using 120 volt external power, be certain switch is off, and power disconnected to avoid electrical shock before work is performed on this heater.

Since PVI cannot control the use of the water heater, water conditions, or maintenance, the warranty on the water heater does not cover poor performance, structural failure, or leaking due to an excessive accumulation of scale.

Free Manuals Download Website

<http://myh66.com>

<http://usermanuals.us>

<http://www.somanuals.com>

<http://www.4manuals.cc>

<http://www.manual-lib.com>

<http://www.404manual.com>

<http://www.luxmanual.com>

<http://aubethermostatmanual.com>

Golf course search by state

<http://golfingnear.com>

Email search by domain

<http://emailbydomain.com>

Auto manuals search

<http://auto.somanuals.com>

TV manuals search

<http://tv.somanuals.com>