

PYLE[®] **PRO**

PYD-710/PYD-720 2 channel **Scratch** mixer

Trickster



owner's manual

▼ Please complete warranty card, detach and return ▼

Thank you for purchasing this PYLE product. To activate your warranty, please mail this card within 10 days.

warranty registration card

PYLE PRO MIXERS

Name _____

Address _____

City, State ZIP _____

Model No. _____ Serial # (if available) _____

Date of Purchase _____

Purchased at:

Music Products Store Sound Contractor/Installer Mail Order
 Catalog Merchandiser Other _____

Your PYLE PRO Series Performance Mixer

is a sophisticated control center, perfect for mixing sound from multiple playback sources such as microphones, tuners, CD players, turntables or the audio outputs from a VCR. This mixer is ruggedly constructed for home or professional use. Wide range volume controls permit you to adjust sound levels accurately to achieve just the right mix for playing through your speaker system or for recording.

Please read this manual thoroughly before you attempt to set up and use the mixer. It contains a range of suggestions and instructions to insure safe usage. Set up and used properly, you can expect years of trouble-free service from this product.

Owner's Manual Table of Contents

- | | | | |
|---|-------------------------------------|---|------------------------------------|
| i | Input/Output Features | 6 | Using the Microphone |
| 1 | Features and Controls: PYD-710/720 | 7 | Using the Crossfader |
| 2 | Presetting Controls Before Use | | Using the Tone Controls (PYD-720) |
| | Connecting the Outputs | | Using the Master Level Controls |
| | Playing the Mixer's Output Signal | 8 | Using the Punch Controls (PYD-720) |
| | Recording the Mixer's Output Signal | | Troubleshooting |
| 3 | Using Headphones | | Care and Maintenance |
| 4 | Using the Mixer Controls | 9 | Specifications |
| | | | Warranty |

Input/Output Features: PYD710/720

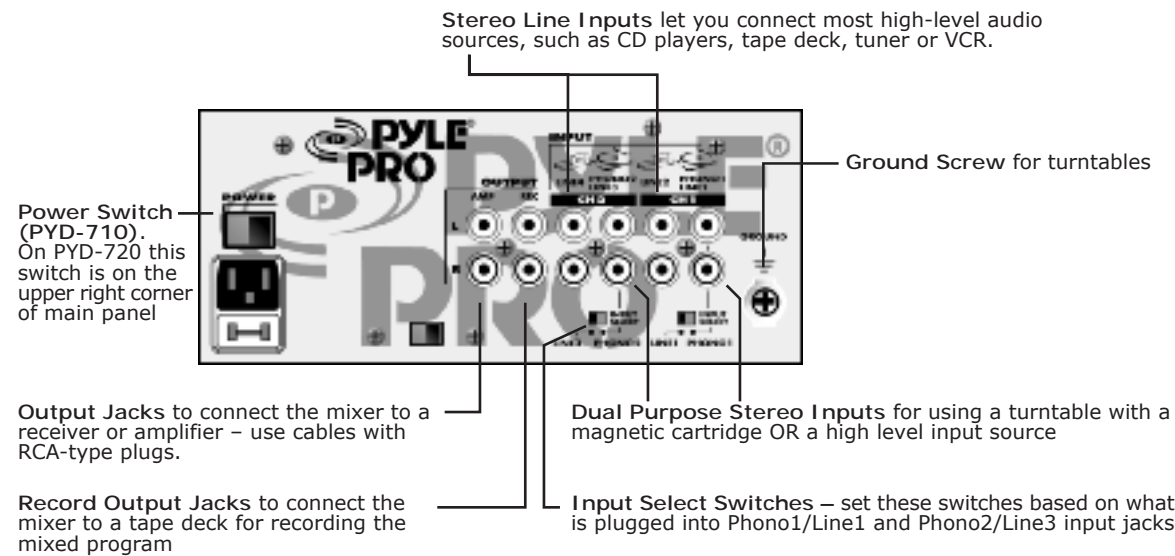

Features and Controls: PYD710/720 Mixer

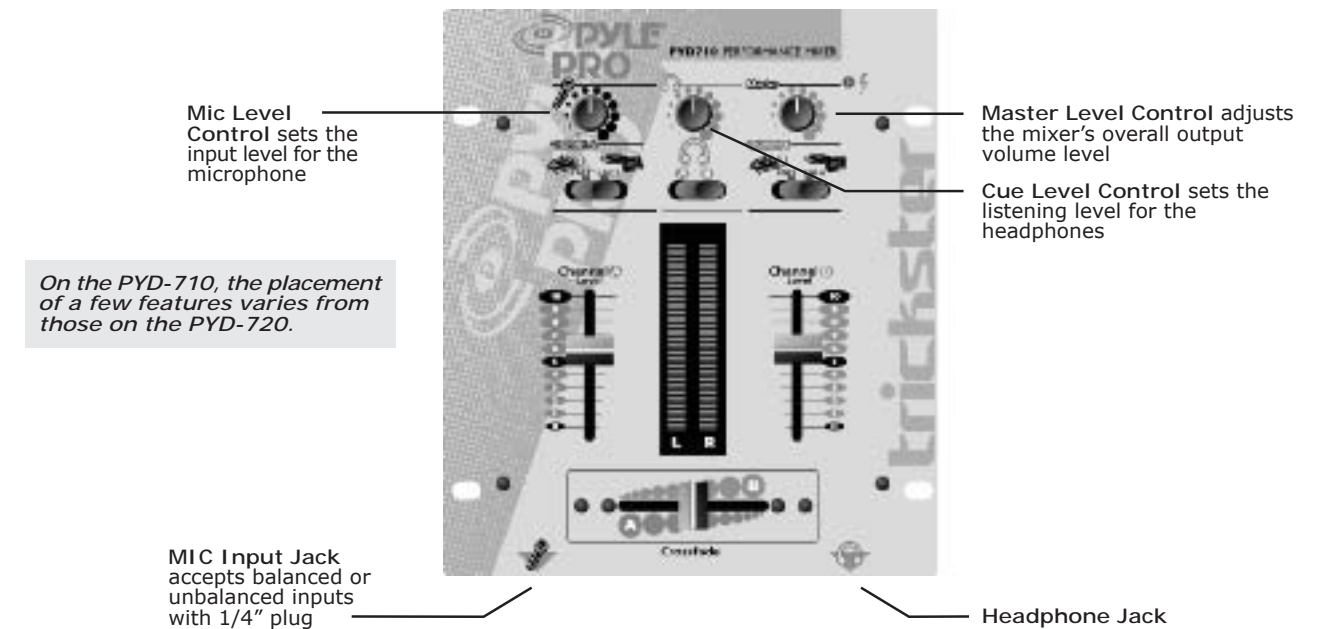
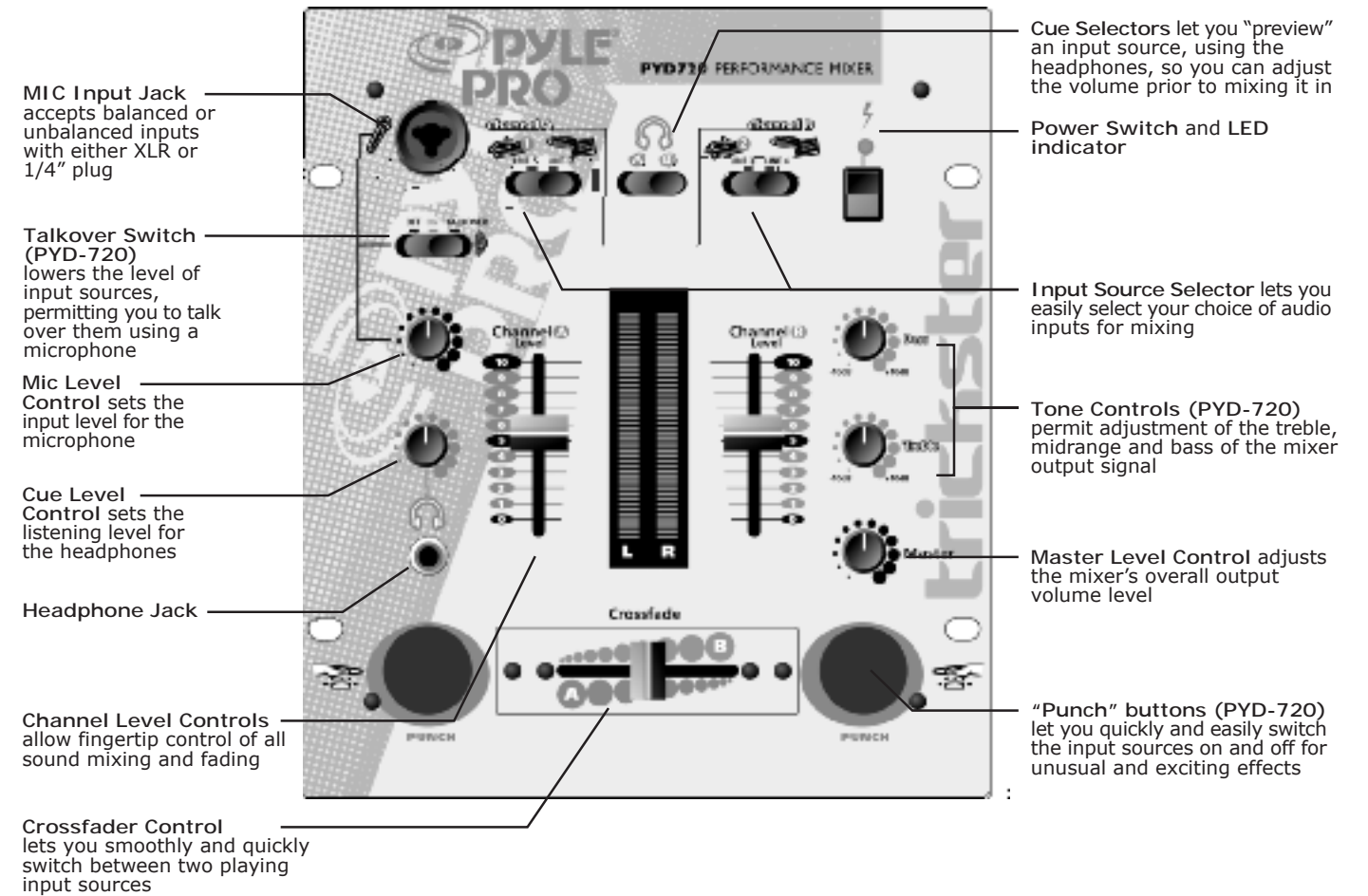

Presetting the Controls Before Use

Since sudden high output levels from your Pyle Pro mixer can damage not only audio devices connected to the mixer output but your hearing as well (especially if you are using headphones), please adjust the mixer's controls BEFORE connecting AC power or turning on the unit.

Set up the mixer controls like this before you start:

CONTROL	SETTING
Power On/Off	OFF
Balance	MID
Gain	MID
Tone Controls, Treble, Mid and Bass	0
MIC 1/2, CH 1/2/3, Master and Cue Levels	0
Crossfader	CENTER

Connecting the Outputs

After presetting the controls (above), you can then connect the mixer's output jacks to the output devices' input jacks. Before connecting these devices, however, be sure to preset their controls to avoid any damage to your equipment due to unexpected high output levels.

Set the output devices' controls like this before you start:

OUTPUT DEVICE	CONTROL	SETTING
Tape Deck	POWER	OFF
Amplifier/Receiver	POWER	OFF
	TONE	FLAT

Playing the Mixer's Output Signal

To play the mixer's output signal through your speaker system (for events such as parties, dances, conferences, etc.) connect an audio patch cord with RCA-type jacks (not supplied) from the mixer's MASTER L and R jacks to your receiver/amplifier's left and right input jacks.

Recording the Mixer's Output Signal

To record the mixer's output signal, connect audio patch cords (not supplied) from the mixer's REC (Record) L and R jacks to your tape deck's left and right input jacks.

Connecting the Mixer Inputs

This mixer permits connection of up to five (5) audio input sources, including a microphone. Such a system might include, for example:

One Microphone
Two Turntables
Two CD players

One Microphone
One Turntable
Two CD players
One Cassette Deck

One Microphones
One Turntables
One CD player
One Cassette Decks
One VCR

One Microphone
Two Turntables
One CD player
One Rhythm Synth

Please observe the following:

Do not connect any audio source with a HIGH LEVEL OUTPUT to the LOW LEVEL PHONO 1 or PHONO 2 mixer audio input jacks (an audio source output with a volume control is HIGH LEVEL).

Connect audio inputs as follows:

1. DJ Microphone. Connect the DJ's Microphone (not supplied) to the mic input jack. The special combo jack on the PYD-720 permits you to connect with either a 1/4" plug or XLR plug.

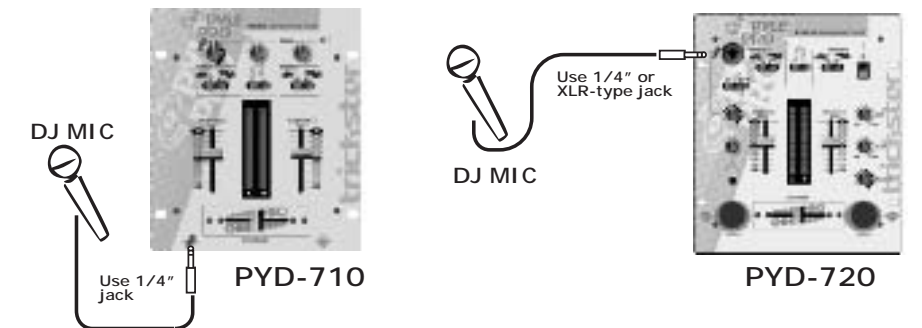

2. High Level Output Audio Sources. Connect up to 4 such sources (tuner, cassette deck, CD Player, camcorder or VCR) to the input jacks for Line 1 (if not being used as Phono 1 input), Line 2, Line 3 (if not being used as Phono 2 input), and Line 4. Please note that Phono 1 and Line 1 (as well as Phono 2 and Line 3) use the same jacks. The selector switch(es) below the jacks should be set to Line position if the jacks are used for the High Level input sources described here.

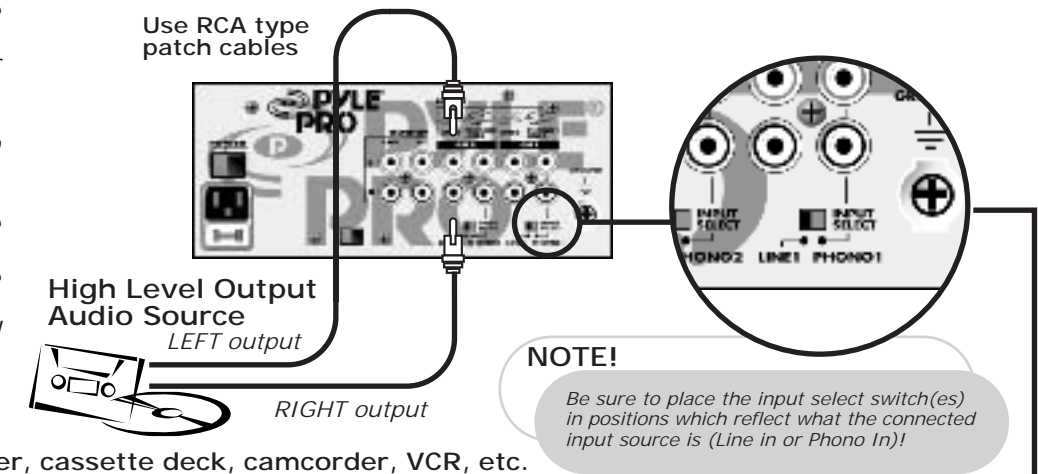

3. Turntables. Connect up to 2 turntables to the Phono 1 and Phono 2 input jacks. Please note that Phono 1 and Line 1 (as well as Phono 2 and Line 3) use the same jacks. The selector switch below the jacks should be set to Phono position if the jacks are used for phono inputs.

When using a turntable, you should also securely connect its ground wire (usually green or black) to the Ground screw on the input panel of the mixer.

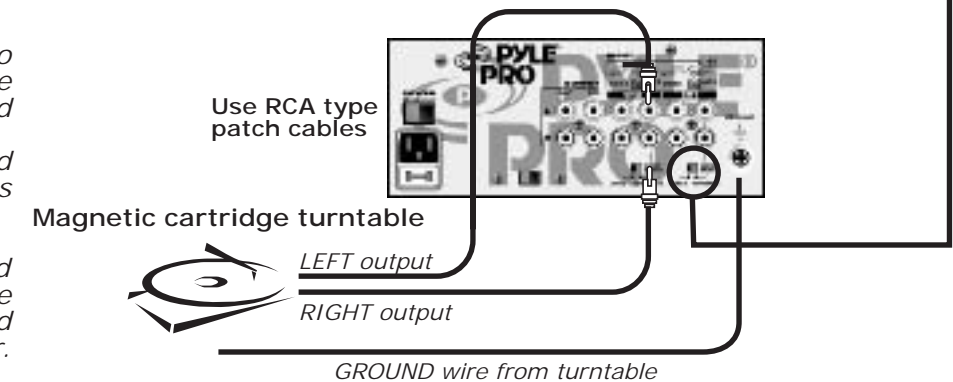

Using Headphones

Plug a pair of stereo headphones (not supplied) with a 1/4" jack into the Phones input. Using headphones not only affords you the opportunity to listen privately, but also enables you to monitor the incoming audio sources so you can locate an exact passage or section before mixing it in. It also gives you the opportunity to set up the relative volume level of the upcoming passage before it joins the mix.

Listen Safely! Please observe the following:

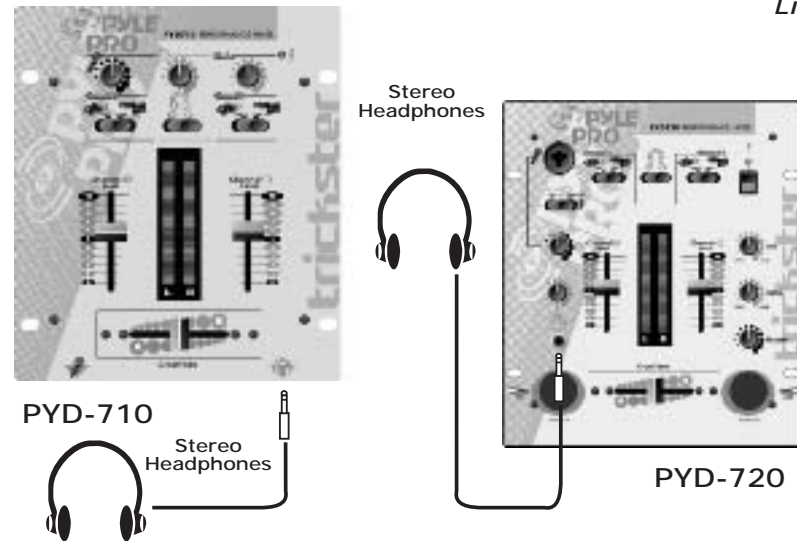

Do not listen at extremely high volume levels. Extended, high-volume listening can lead to permanent hearing loss. Follow these guidelines to protect your hearing, especially when using headphones.

Always start by setting the volume level to the lowest possible level before listening.

Put headphones on, and then gradually increase the volume as necessary.

Once you set the volume level do not increase it. Over a period of time, your ears adapt to a volume level and there is a temptation to increase it. Even though such an increase may not cause discomfort, it might still damage your hearing.

Using the Mixer Controls

Turning on the Mixer

1. Turn on the output amplifier and temporarily set its volume to the minimum setting.
2. On the mixer, turn ON the power switch. The adjacent power LED will illuminate.
3. Turn on the audio input sources you wish to mix, and set them to play (or talk continuously into the microphone).
4. To monitor the audio input sources so that you can decide when to mix in each input, see "Monitoring 'Cueing' the Inputs."
5. To mix the audio input sources so that you can play them through your amplifier system or record them on your tape deck, see "Mixing the Inputs."

Monitoring ("Cueing") the Inputs

Follow these steps to monitor the audio input sources.

1. Perform Steps 1 and 2 of "Turning on the Mixer" and put headphones on.
2. Set the CUE switch to the channel you wish to monitor (CH A or CH B).

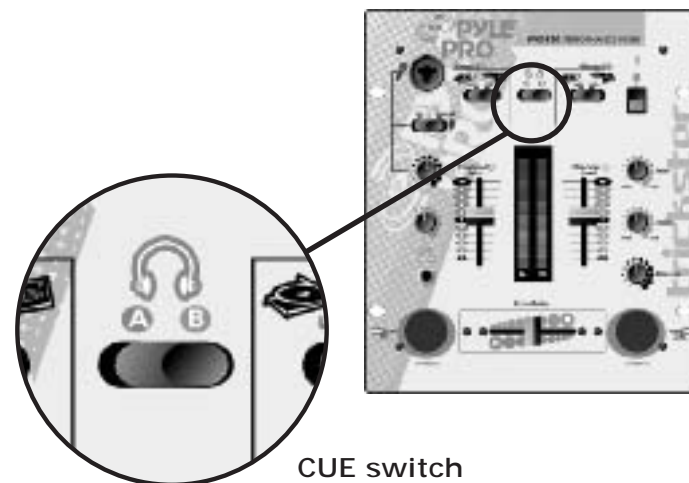

CUE switch

3. Set the desired audio input source's volume to its minimum setting, turn it on, and set it to play (or speak continuously into the microphone).
4. Slowly turn the CUE LEVEL control clockwise until you hear the signal through the headphones at the desired volume level.

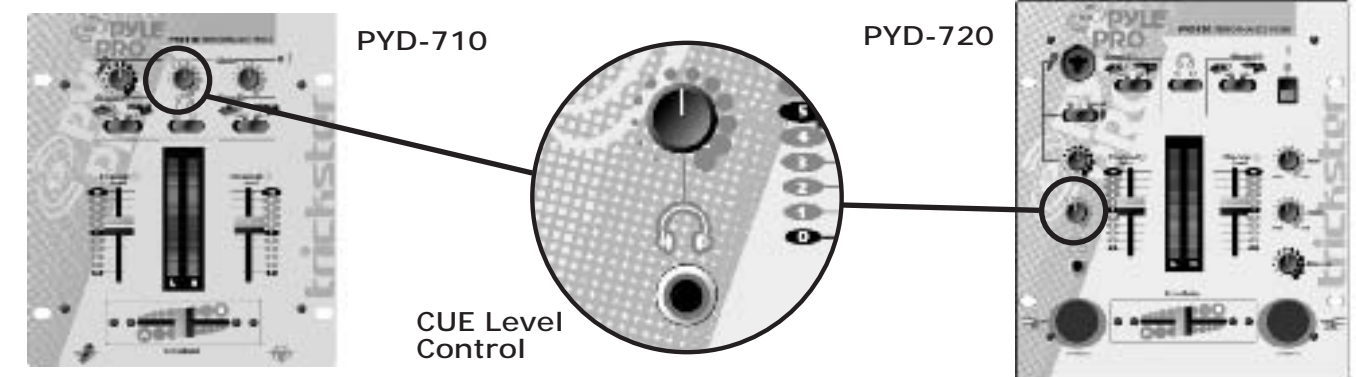

5. Repeat Steps 2-4 to select and adjust the volume level of the other audio input sources, one at a time.

Mixing the Inputs

Follow these steps to mix the audio input sources.

1. Perform Steps 1 and 2 of "Turning on the Mixer."
2. Set the selected audio input source's volume to its minimum setting, turn it on, and set it to play (or speak continuously into the microphone).
3. Set the following input source selectors as desired:

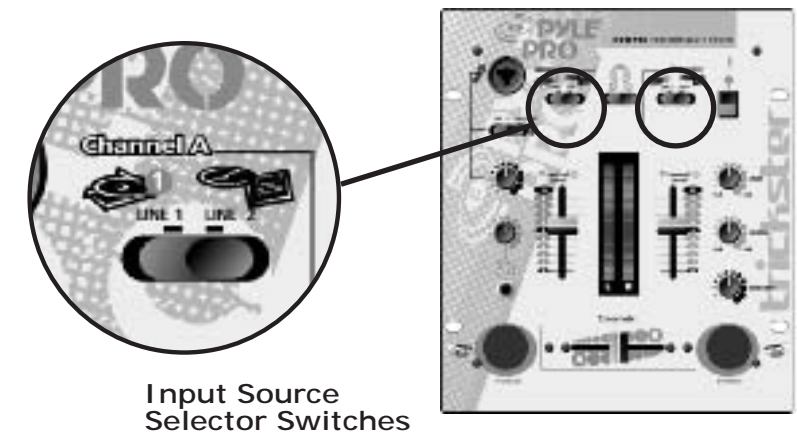

Input Source Selector Switches

Mixer Channel	Audio Input Source	Input Selector Switch Setting
A	Turntable connected to PHONO1/LINE 1 jacks	PHONO1
	High level output audio source connected to the PHONO1/LINE 1 jacks	LINE1
	High level output audio source connected to the LINE 2 jacks	LINE2
B	Turntable connected to PHONO2/LINE 3 jacks	PHONO2
	High level output audio source connected to the PHONO2/LINE 3 jacks	LINE3
	High level output audio source connected to the LINE 4 jacks	LINE4

Mixing the Inputs, cont.

4. Set the Channel A and Channel B volume control sliders to approximately 8-10.
5. Rotate the Master Volume Control clockwise until you observe an average reading of "0" (zero) on both Output Level LED meters, and leave it at that setting. (Please note that the Output Level LED meter indicates the total output signal being mixed from all sources for each of the Left and Right channels.)
6. When adding an audio input source to the mix, adjust the corresponding Channel A and B volume control sliders so you maintain the average reading of "0" on both Output Level LED meters.
7. Adjust the receiver/amplifier volume control (not the mixer's) to the desired volume.
8. To turn off the mixer, push the Power switch to the OFF position; the Power LED will be extinguished.

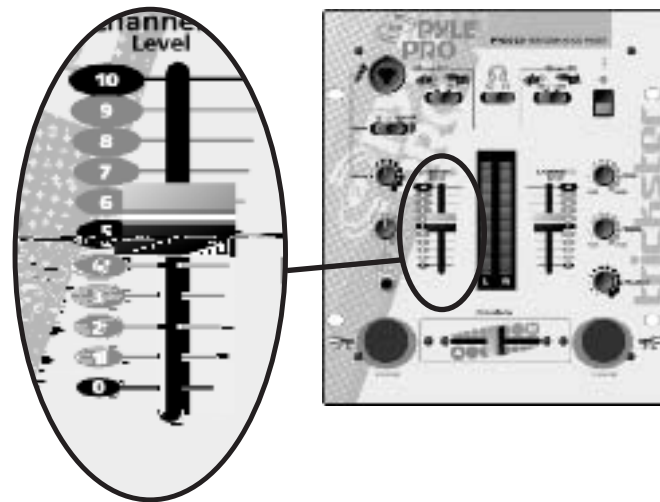

Input Source
Volume Control Sliders

Using the Microphone Incorporating Voice into the Mix

To blend voice from the microphone with the audio program material, adjust the MIC level slider to increase or decrease the microphone level. This will not affect the main volume inputs. When the microphone is not in use, set the MIC level slider to "0."

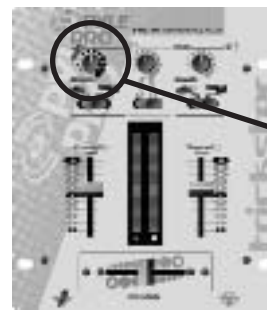

PYD-710

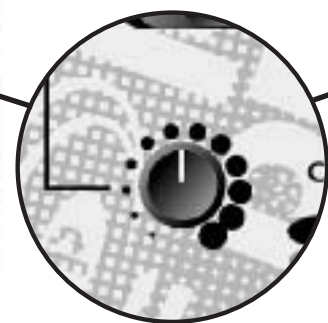

Microphone Level
Control

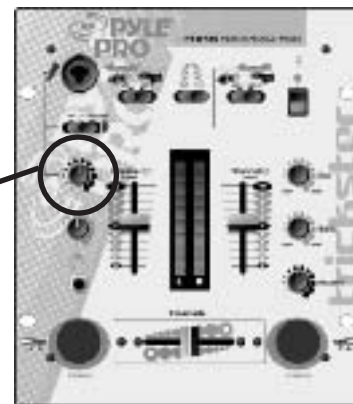

PYD-720

Talkover Mode (PYD-720)

When mixing the mic into the mix, you would usually leave the Talkover switch in the ON position. In special situations, however, the PYD-720's Talkover mode allows a voice to be heard clearly through the microphone by attenuating all the other audio input sources.

This mode is engaged by setting the Talkover Switch to the TALKOVER position. When not using the microphone, set this switch to the OFF position.



Talkover Switch

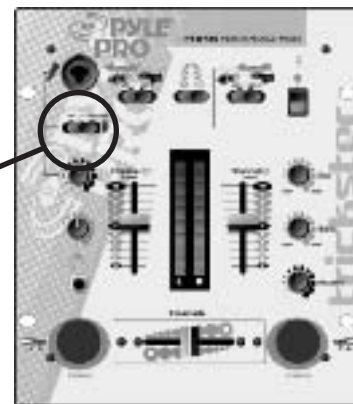

Using the Crossfader

When the crossfade slider is in the center position, the two assigned channels play equally. Sliding the control towards the A position will increase the level of A and fade out B proportionally to the distance from center. Likewise, sliding the control towards the B position will increase the level of B and fade out A.

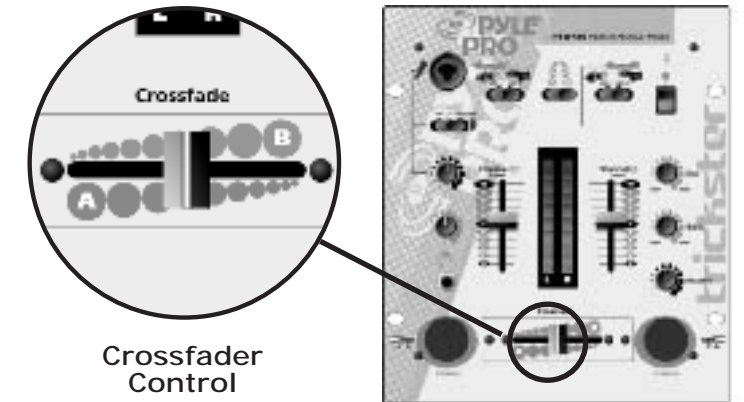

Crossfader
Control

Using the Tone Controls (PYD-720)

To enhance the sound or tailor the highs, mids and low frequencies for each audio source input to the acoustics of a particular performance environment, you can adjust the BASS and TREBLE tone controls.

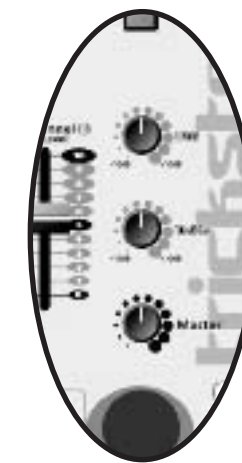

Tone Controls

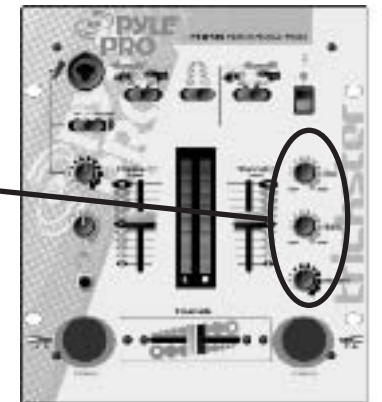

Using the Master Level Control

The overall volume of the mix of all inputs is adjusted using the Master Level control. Turning this control clockwise increases the overall system volume.

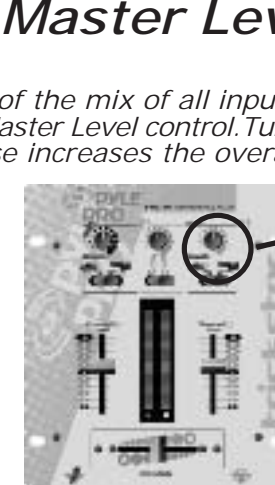

PYD-710

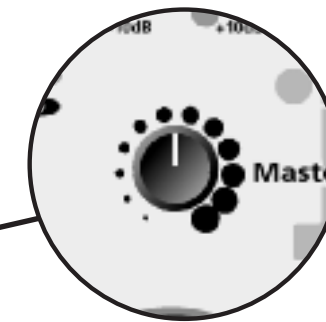

Master Level
Control

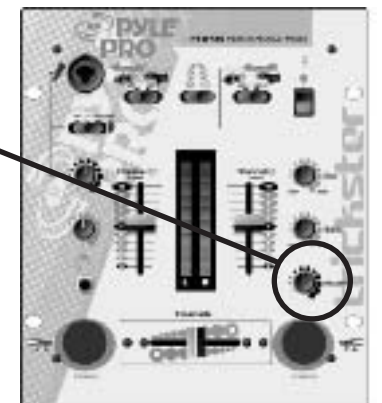

PYD-720

Using the "Punch" Controls (PYD-720)

This featured control lets you smoothly and quickly turn a playing source on and off, or switch between the two different input sources assigned to Crossfade Channel A and B.

The effect you get depends upon the position of the Crossfader.

With the Crossfader at 100% Channel A (all the way to the left), pressing the Channel A Punch Button will mute the Channel A material.

Similarly, with the Crossfader at 100% Channel B (all the way to the right), pressing the Channel B Punch Button will mute the Channel B material.

With the Crossfader in the middle position, press the Channel A punch button and the Channel A material will be subtracted from the mix, leaving only Channel B material. Likewise, press the Channel B punch button and the Channel B material will be subtracted from the mix.

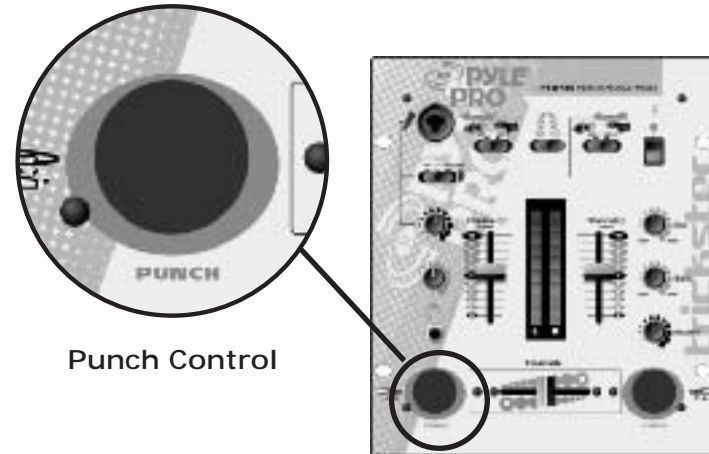

Punch Control

Troubleshooting

Your mixer should require very little maintenance. If you have problems, refer to the chart below for possible solutions. If you cannot solve the problem, contact a qualified technician for assistance.

PROBLEM	POSSIBLE SOLUTION
Nothing works	<ul style="list-style-type: none"> • Check the AC connection. Make sure the AC outlet is "live." • Check the power connection to the rest of the system (receiver/amplifier, etc.)
No signal from an audio input source	<ul style="list-style-type: none"> • Check the control setting • Check the connection between the mixer and the input source
Hum from PHONO	<ul style="list-style-type: none"> • Check that the turntable's ground wire (usually black or green) is fastened securely to the GROUND SCREW on the mixer input panel
Hum from other source	<ul style="list-style-type: none"> • Make sure there are no low level inputs connected to the LINE input jacks
Feedback is present	<ul style="list-style-type: none"> • Move the microphone further away from the output speakers, or use a directional microphone

Care and Maintenance

Your Pyle Pro Mixer is an example of superior design and craftsmanship. The following suggestions will help you care for your mixer so you can enjoy years of use:

- Keep the mixer dry. If it gets wet, wipe immediately.
- Use the mixer only in well-ventilated installations.
- Handle the mixer gently and carefully - do not drop!
- Keep the mixer away from dust and dirt.
- Wipe occasionally with a damp cloth to keep it looking new. Do not use harsh chemicals, solvents or detergents!

Specifications

PYD710/720

Input Sensitivity/Impedance

Mic	1.5 mV/600 Ohms
Phono 1-2	3.0 mV/50K Ohms
Line 1-4	150.0 mV/27K Ohms

Output Level

Main Out	2.0 V/10-kOhms
Record	120mV/10-kOhms

Frequency Response

20Hz – 20kHz +/- 3 dB

S/N Ratio (at 1 kHz)

Mic	55 dB/1.5mV input
Phono	65 dB/3.0mV input
Line	70 dB/150.0 mV input

Distortion

Mic	0.50%
Phono	0.08%
Line	0.05%

Tone Control

Treble	10kHz: +/- 10dB
Bass	100Hz: +/- 10dB

Talkover Attenuation

-16dB

Power Source

120 VAC, 60Hz/230 VAC, 50 Hz

Dimensions, inches (mm)

Model PYD-170:
7.5 x 3.4 x 8.7
(190 x 86 x 220)

Model PYD-720:
8.7 x 3.4 x 10.0
(220 x 86 x 254)

Weight, lbs (kg)

Model PYD-710/PYD-720
4.4 (2.0)/5.5 (2.5)

Limited Warranty

All PYLE PRO products are carefully constructed and tested before shipment. Units purchased in the USA are warranted to be free of defects in material and workmanship for two (2) years from the date of purchase. This warranty is limited to the original retail purchaser of the mixer.

Should the unit fail due to factory defects in material or workmanship, your unit will be repaired or replaced at the sole discretion of PYLE.

To obtain warranty service, you must first call our Consumer Return Hotline at (718) 236-6948 to obtain a Return Authorization Number. This R.A. # must appear on the outside of your package and on all paperwork relating to your return.

When returning the unit to us for warranty service, it must be carefully packed and shipped, prepaid, to:

R.A.#: _____
PYLE PRO Service Center
1600 63rd Street
Brooklyn, NY 11204

You must also include the following items with your return:

- A copy of your sales receipt or other proof of purchase
- A brief letter, indicating the problem you are experiencing with the product
- Include in your letter your return address, daytime phone number and R.A. number
- Also include a check or money order for \$15.00 for return shipping, handling and insurance, or provide your Visa/MC number with expiration date.

Our obligation under this warranty is limited to the repair or replacement of the defective unit when it is returned to us prepaid. This warranty will be considered void if the unit was tampered with, improperly serviced or subject to misuse, neglect or accidental damage.

Place
Stamp
Here

Please complete warranty card, detach and return

PYLE
PYLE PRO Audio, Inc.
1600 63rd Street
Brooklyn, NY 11204

Free Manuals Download Website

<http://myh66.com>

<http://usermanuals.us>

<http://www.somanuals.com>

<http://www.4manuals.cc>

<http://www.manual-lib.com>

<http://www.404manual.com>

<http://www.luxmanual.com>

<http://aubethermostatmanual.com>

Golf course search by state

<http://golfingnear.com>

Email search by domain

<http://emailbydomain.com>

Auto manuals search

<http://auto.somanuals.com>

TV manuals search

<http://tv.somanuals.com>