

ESPAÑOL: PÁGINA 13
FRANÇAISE : PAGE 25

Instruction manual

FLOORING CLEAT NAILER



MODEL FCN200

Patent No: 6,155,472

IMPORTANT

Please make certain that the person who is to use this equipment carefully reads and understands these instructions before starting operations.

The Model and Serial No. plate is located on the main housing of the tool. Record these numbers in the spaces below and retain for future reference.

Model No. _____

Type _____

Serial No. _____

Part No. 899223 (015)

To learn more about Porter-Cable visit our website at:

<http://www.porter-cable.com>

PORTER-CABLE
PROFESSIONAL POWER TOOLS

Copyright © 2001 Porter-Cable Corporation

IMPORTANT SAFETY INSTRUCTIONS

⚠ WARNING: When using pneumatic tools, basic safety precautions should always be followed to reduce the risk of personal injury, including the following:

READ AND FOLLOW ALL INSTRUCTIONS.

There are certain applications for which this tool was designed. Porter-Cable strongly recommends that this tool NOT be modified and/or used for any application other than for which it was designed. If you have any questions relative to its application DO NOT use the tool until you have written Porter-Cable and we have advised you.

Technical Service Manager
Porter-Cable Corporation
4825 Highway 45 North
Jackson, TN 38305

1. USE SAFETY GLASSES. To prevent eye injuries, the tool operator and all persons in the work area must wear safety glasses with permanently attached, rigid, plastic side shields. These safety glasses must conform to ANSI Z87.1 requirements (approved glasses have "Z87" printed or stamped on them). Fig. 1.

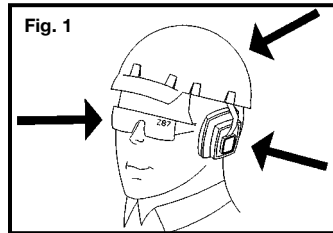

2. WEAR EAR PROTECTION to safeguard against possible hearing loss. Fig. 1.

3. OPERATOR AND BYSTANDERS WEAR HARD HAT to safeguard against possible injuries. Fig. 1.

4. USE CLEAN, DRY, REGULATED compressed air at 70 to 100 PSI, (4.8 to 6.9 BAR). Fig. 2.

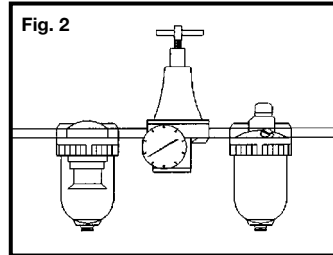

5. DO NOT CONNECT TOOL TO pressure which potentially exceeds 200 PSI (13.8 BAR). Fig. 3.

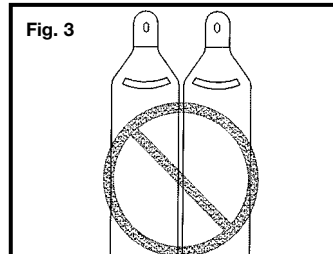

6. ONLY USE AIR HOSE THAT IS RATED for a maximum working pressure of at least 150 PSI or 150% of the maximum system pressure, whichever is greater.

7. NEVER USE OXYGEN, CARBON DIOXIDE, combustible gases or any other bottled gas as a power source for this tool: explosion and serious personal injury could result. Fig. 3.

8. CONNECT TOOL TO AIR SUPPLY HOSE with a coupling that removes all pressure from the tool when the coupling is disconnected. Fig. 4.



9. DISCONNECT TOOL FROM AIR SUPPLY HOSE before doing tool maintenance, clearing a jammed fastener, leaving work area, moving tool to another location, handing the tool to another person, or making adjustments. Fig. 5.



10. NEVER USE A TOOL that is leaking air, has missing or damaged parts, or requires repair. Make sure all screws and caps are securely tightened.

11. NEVER USE TOOL IF TRIGGER mechanism is inoperable, missing or damaged. Do not alter or remove trigger mechanism. Make daily inspections for free movement of trigger mechanism.



12. DO NOT USE TOOL WITHOUT SAFETY WARNING LABEL. If label is missing, damaged or unreadable, contact your Porter-Cable Service Center for a replacement. Fig. 6.

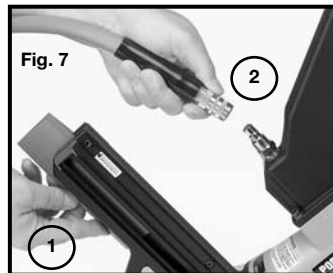

13. ONLY USE PARTS, FASTENERS, AND ACCESSORIES recommended by Porter-Cable.

14. REMOVE ALL FASTENERS from tool before connecting to air supply. The tool's driving mechanism may cycle when tool is connected to the air supply. Fig. 7.



15. ALWAYS ASSUME THE TOOL CONTAINS FASTENERS. Keep the tool pointed away from yourself and others at all times. No horseplay. Respect the tool as a working implement. Fig. 8.

16. DO NOT LOAD FASTENERS with trigger depressed, to prevent unintentional firing of a fastener. Fig. 9.

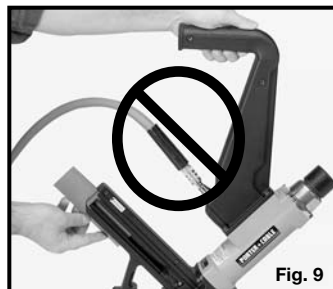

17. REMOVE FINGER FROM TRIGGER

when not driving fasteners. Never carry tool with finger on trigger: tool will fire a fastener if rubber cap is bumped while trigger is depressed. Fig. 10.

**18. USE THE MALLET TO RACK THE WOOD STRIP, NOT THE NAILER.** Fig. 11.

19. DO NOT USE THE METAL END OF THE MALLET TO STRIKE THE PLUNGER, use the rubber capped end only.

20. FIRE FASTENERS INTO WORK SURFACE ONLY: never into materials too hard to penetrate.

21. DO NOT USE THE NAILER TO POSITION the flooring strips. Hitting the rubber cap without first activating the trigger will cause severe internal damage to the Nailer. Fig.12.



22. THE TRIGGER IS A SAFETY DEVICE and should only be pulled when the Nailer is in proper position on the work surface and before the rubber cap is struck with the mallet. Do not tie or tape down the safety trigger as the Nailer could discharge if dropped on the rubber cap. The Nailer will not fire unless the trigger is pulled before the mallet blow. Fig.13.



23. DO NOT DRIVE FASTENERS on top of other fasteners: the fasteners can ricochet causing personal injury.

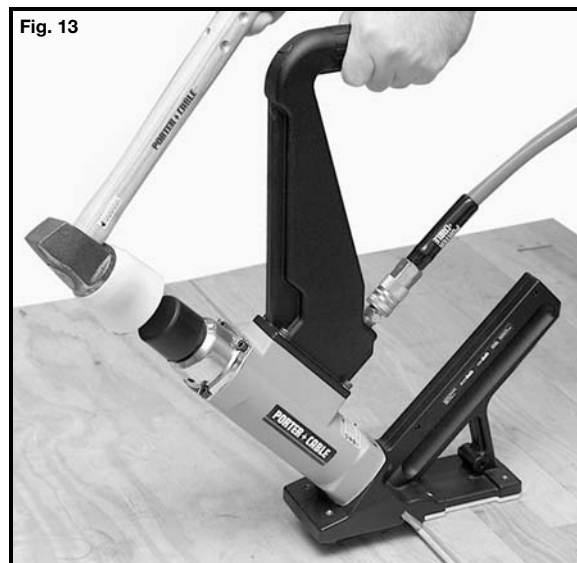

EMPLOYER'S RESPONSIBILITIES

⚠ WARNING: Employer must enforce compliance with the safety warnings and all other instructions contained in this manual.

Keep this manual available for use by all people assigned to use this tool.

For personal safety and proper operation of this tool, read and follow all of these instructions carefully.

OPERATING INSTRUCTIONS

FOREWORD

Porter-Cable Model FCN200 is a heavy duty, pneumatic flooring cleat nailer. It is designed to install tongue and groove hardwood flooring with L-shaped flooring cleats. Flooring in thicknesses of $\frac{1}{2}$ " and $\frac{25}{32}$ " can be installed using 1- $\frac{1}{2}$ " and 2" length flooring cleats respectively. See ACCESSORIES Listing in back of this manual.

CAUTION: Use approved Porter-Cable flooring cleats only. Porter-Cable flooring cleats are made with special design features with superior holding strength. See ACCESSORIES Listing in back of this manual.

POWER SOURCE

This tool is designed to operate on clean, dry, compressed air at regulated pressures between 70 and 100 PSI (Pounds per Square Inch)(4.8 to 6.9 Bar). The preferred system would include a filter, a pressure regulator, and an automatic oiler located as close to the tool as possible (within 15 feet is ideal).

All compressed air contains moisture and other contaminants that are detrimental to internal components of the tool. An air line filter will remove most of these contaminants and significantly prolong the life of the tool. If an in-line oiler is not available: place 10 to 15 drops of Porter-Cable Air Tool Oil (see ACCESSORIES), into the tool's air inlet at the beginning of each workday.

IMPORTANT: Do not over lubricate the Nailer, excess oil mist or drops will be vented with spent air when over lubricated. Excess oil could stain the wood flooring, walls or furnishings. Dry fire the Nailer, without nails, to purge excess oil, before you begin nailing.

The tool is equipped with a $\frac{1}{4}$ " male "quick connector". A $\frac{3}{8}$ " male "quick connector" is available from Porter-Cable and may be used in situations where a $\frac{1}{4}$ " supply line is not available. The tool must always be connected to the air supply with a coupling such that all pressure is removed from the tool when the coupling is disconnected.

⚠ WARNING: All air line components (hoses, connectors, filters, regulators, etc.) must have a minimum working pressure rating of at least 150 PSI (10.3 BAR) or 150% of maximum system potential, whichever is higher.

Do not connect this tool to a system with maximum potential pressure greater than 200 PSI, (13.8 BAR).

Only connect tool to air supply with a coupling that will release all pressure from the tool when disconnected.

Disconnect tool from air supply before performing maintenance, clearing a jammed fastener, leaving work area, moving tool to another location, handing the tool to another person, or making adjustments.

PREPARING THE TOOL

1. After reading and understanding this entire manual, connect tool to air supply (see Fig. 15).

⚠ WARNING: Keep tool pointed away from yourself and others at all times.

Always connect tool to air supply before loading fasteners. Do not load fasteners with trigger depressed.

Use only approved Porter-Cable fasteners (see ACCESSORIES).

Always wear Z87.1 approved safety glasses, and hearing protection when preparing or operating the tool.

Never use a tool that leaks air or needs repair.

2. Orient a strip of L-shaped cleats with points down (see Fig. 16), and align with the slot (L) at the end of the magazine.

3. Feed the strip of cleats into the magazine

4. Pull the follower (B) Fig. 17, all the way to the rear of the magazine and release. The follower will apply pressure to the strip of cleats to feed it into the driving mechanism.

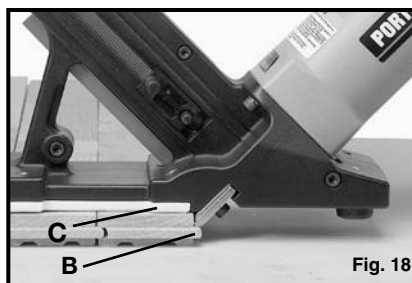
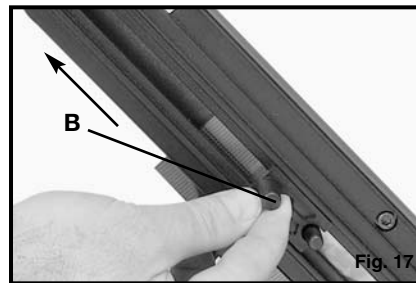
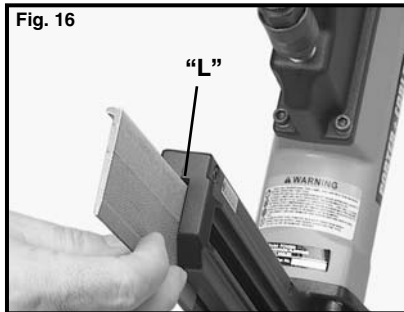
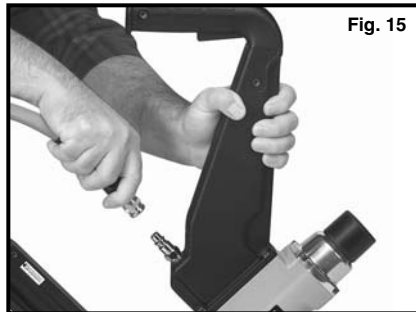

USING THE TOOL

Complete all steps of PREPARING THE TOOL before using the tool.

First position and closely fit together (rack) the flooring strip with the (metal) mallet. Position the tool on the tongued edge of the flooring strip (see Fig. 18) aligning the driver guide against the front of the flooring strip. Pull and hold the trigger and strike the rubber cap with the rubber mallet. The tool will then drive the cleat at the correct 45 degree angle as shown in Fig. 19 and 20. The proper length of flooring cleat to use with various thicknesses of flooring is also shown in Fig. 19 and 20.

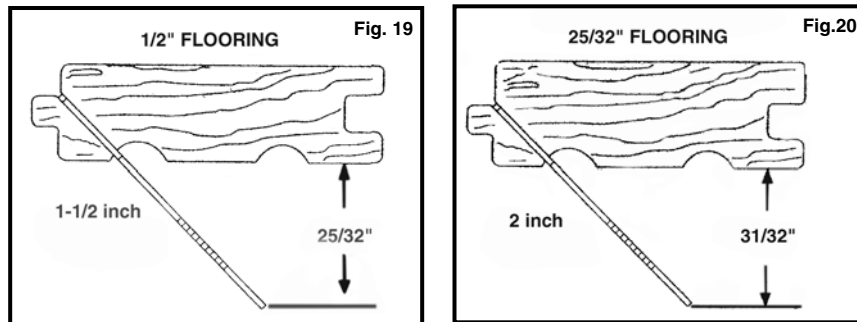

It is not necessary to hit the rubber cap hard to activate it. Never hit the tool hard with excessive force, as this will damage the tool.

DO NOT USE THE NAILER TO POSITION the flooring strips. Hitting the rubber cap without first activating the trigger will cause severe internal damage to the Nailer.

DO NOT USE THE METAL END OF THE Mallet TO STRIKE THE RUBBER CAP, use the rubber end only.

⚠ WARNING: The trigger is a safety device and should only be pulled when the tool is in the proper position on the work surface and before the rubber cap is struck with the mallet. Do not tie or tape down the safety trigger as the tool could discharge if dropped on the rubber cap. The tool will not fire unless the safety trigger is pulled before the mallet blow.

NOTE: When Using Tool to install Pre-finished Flooring

The Porter-Cable FCN200 was designed for installing both unfinished and pre-finished hardwood flooring. Care must be used however when installing pre-finished flooring to ensure that the finish is not damaged by the tool. It is recommended that the tool be inspected for damage [especially the base plate (C) Fig.18] and tested on a sample section to be certain that the tool and technique of use do not mar the finish. This procedure should be followed before each job due to variations in flooring and tool condition.

⚠ WARNING: Remove finger from trigger when not driving fasteners. Never carry tool with finger on trigger: tool will fire a fastener if rubber cap is bumped.

⚠ WARNING: Keep tool pointed in a safe direction at all times.

- ⚠ WARNING:** Never attempt to drive a fastener into material that is too hard. The fastener can ricochet causing personal injury.
- ⚠ WARNING:** Disconnect tool from air supply before performing maintenance, clearing a jammed fastener, leaving work area, moving tool to another location, handing the tool to another person, making adjustments.
- ⚠ WARNING:** Clean and inspect tool daily. Carefully check for proper operation of trigger mechanism. **Do Not** use the tool unless the trigger mechanism is functional. **Do Not** use if the tool is leaking air or needs any other repair.

CLEARING A JAMMED FASTENER

1. **CAUTION:** Disconnect tool from air supply.
2. Remove any remaining fasteners from the nailer.
 - A. Pull pusher back by pulling front knob (A) Fig. 21. This will retract the pusher face from the cleat strip.
 - B. Still using the front knob (A) Fig. 22, slide the pusher to the front bypassing the cleat strip.
 - C. Slide the remaining Fasteners out of the magazine. Fig. 23.
3. Use the 3/16" hex wrench to remove the three screws (A) Fig. 24 attaching the Driver Guide Plate and Gate (B) Fig. 24.
4. Slide out the Driver Guide Plate and Gate assembly. Fig. 25.
5. Pull the Driver Guide Plate and Gate assembly apart and remove the jammed Fastener. Fig. 26.
6. Replace the Driver Guide Plate and Gate with three screws.

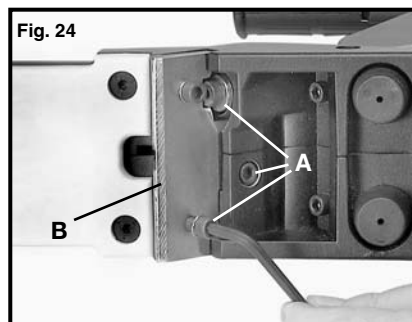

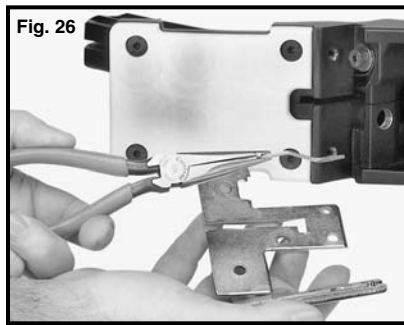
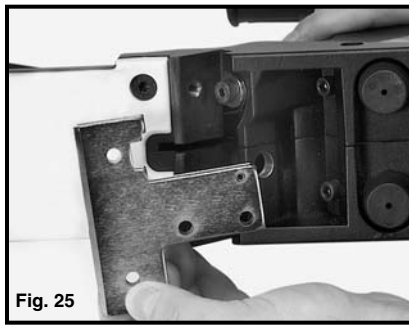

MAINTENANCE

CLEAN AND INSPECT DAILY

CAUTION: Disconnect tool from air supply before cleaning and inspection. Correct all problems before placing the tool back in use.

Wipe tool clean and inspect for wear or damage. Use non-flammable cleaning solutions to wipe exterior of tool only if necessary. DO NOT SOAK tool with cleaning solutions. Such solutions can damage internal parts.

Inspect trigger mechanism to insure system is complete and functional: no loose or missing parts, no binding or sticking parts.

Keep all screws tight. Loose screws can cause personal injury or damage tool.

If tool is used without an in-line oiler: place 10 to 15 drops of Porter-Cable Air Tool Oil into the air inlet of the tool at the beginning of each workday.

IMPORTANT: Do not over lubricate the Nailer, excess oil mist or drops will be vented with spent air when over lubricated. Excess oil could stain the wood flooring, walls or furnishings. Dry fire the Nailer, without nails, to purge excess oil, before you begin nailing.

SERVICE AND REPAIRS

All quality tools eventually require servicing or replacement of parts due to wear from normal use. Some user serviceable components are described in the TROUBLESHOOTING Section. Complete product Service is available from either an AUTHORIZED PORTER-CABLE SERVICE STATION or a PORTER-CABLE/DELTA FACTORY SERVICE CENTER. All repairs made by these agencies are fully guaranteed against defective material and workmanship. We cannot guarantee repairs made or attempted by anyone other than these agencies.

Should you have any questions about your tool, feel free to write us at any time. In any communications, please give all information shown on the nameplate of your tool (model number, type, serial number, etc.).

TROUBLESHOOTING

CAUTION: Disconnect tool from air supply before performing any Service Procedure.

SYMPTOM	PROBLEMS	SOLUTIONS
1. Air leak near top of tool or in trigger area.	Loose screws. Worn or damaged o-rings or seals.	Tighten screws. Install "OVERHAUL" Maintenance Kit.
2. Tool does nothing or operates sluggishly.	Inadequate air supply. Inadequate lubrication. Worn or damaged o-rings or seals.	Verify adequate air supply. Put 10 to 15 drops of oil into air inlet. Install "DRIVER" Maintenance Kit. Install "OVERHAUL" Maintenance Kit.
3. Air leak near bottom of tool.	Loose screws. Worn or damaged o-rings or bumper.	Tighten screws. Install "OVERHAUL" Maintenance Kit.
4. Tool jams frequently.	Incorrect fasteners. Damaged fasteners. Magazine or nose screws loose. Magazine is dirty. Pusher spring damaged. Driver is worn or damaged.	Verify approved fasteners of correct size. Replace w/undamaged fasteners. Tighten screws. Clean magazine. Replace spring. Install "DRIVER" Maintenance Kit.
5. Other.		Contact a Porter-Cable Service Facility.

ACCESSORIES

A complete line of accessories is available from your Porter-Cable · Delta Supplier, Porter-Cable · Delta Factory Service Centers, and Porter-Cable Authorized Service Stations. Please visit our Web Site www.porter-cable.com for a catalog or for the name of your nearest supplier.

⚠ WARNING: Since accessories, other than those offered by Porter-Cable · Delta, have not been tested with this product, use of such accessories could be hazardous. For safest operation, only Porter-Cable · Delta recommended accessories should be used with this product.

CATALOG NO.	DESCRIPTION	LENGTH	QUAN/BOX
FLC150	Flooring Cleat Nails	1-1/2"	1000
FLC200	Flooring Cleat Nails	2"	1000
60076	Overhaul Kit		
60077	Driver Kit		
48248	Wrench Allen 3/16"		
48245	Wrench Allen 5/32"		
884293	Oil (for Air Tools)		
899226	Mallet		

PORTER-CABLE LIMITED ONE YEAR WARRANTY

Porter-Cable warrants its nailing and stapling tools for a period of one year from the date of original purchase. We will repair or replace at our option, any part or parts of the product and accessories covered under this warranty which, after examination, proves to be defective in workmanship or material during the warranty period. For repair or replacement return the complete tool or accessory, transportation prepaid, to your nearest Porter-Cable Service Center or Authorized Service Station. Proof of purchase may be required. This warranty does not apply to o-rings and driver blades or to repair or replacement required due to misuse, abuse, normal wear and tear or repairs attempted or made by other than our Service Centers or Authorized Service Stations.

ANY IMPLIED WARRANTY, INCLUDING THE IMPLIED WARRANTIES OF MERCHANTABILITY AND FITNESS FOR A PARTICULAR PURPOSE, WILL LAST ONLY FOR ONE (1) YEAR FROM THE DATE OF PURCHASE.

To obtain information on warranty performance please write to: PORTER-CABLE CORPORATION, 4825 Highway 45 North, Jackson, Tennessee 38305; Attention: Product Service. THE FOREGOING OBLIGATION IS PORTER-CABLE'S SOLE LIABILITY UNDER THIS OR ANY IMPLIED WARRANTY AND UNDER NO CIRCUMSTANCES SHALL PORTER-CABLE BE LIABLE FOR ANY INCIDENTAL OR CONSEQUENTIAL DAMAGES. Some states do not allow limitations on how long an implied warranty lasts or the exclusion or limitation of incidental or consequential damages, so the above limitation or exclusion may not apply to you.

This warranty gives you specific legal rights and you may also have other legal rights which vary from state to state.

PORTER-CABLE • DELTA SERVICE CENTERS (CENTROS DE SERVICIO DE PORTER-CABLE • DELTA) (CENTRE DE SERVICE PORTER-CABLE • DELTA)

Parts and Repair Service for Porter-Cable • Delta Power Tools are Available at These Locations
(Obtenga Refaccion de Partes o Servicio para su Herramienta en los Sigüientes Centros de Porter-Cable • Delta)
(Locations où vous trouverez les pièces de rechange nécessaires ainsi qu'un service d'entretien)

<p>ARIZONA Tempe 85282 (Phoenix) 2400 West Southern Avenue Suite 105 Phone: (602) 437-1200 Fax: (602) 437-2200</p> <p>CALIFORNIA Ontario 91761 (Los Angeles) 3949A East Guasti Road Phone: (909) 390-5555 Fax: (909) 390-5554</p> <p>San Leandro 94577 (Oakland) 3039 Teagarden Street Phone: (510) 357-9762 Fax: (510) 357-7939</p> <p>FLORIDA Davie 33314 (Miami) 4343 South State Rd. 7 (441) Unit #107 Phone: (954) 321-6635 Fax: (954) 321-6638</p> <p>Tampa 33609 4538 W. Kennedy Boulevard Phone: (813) 877-9585 Fax: (813) 289-7948</p> <p>GEORGIA Forest Park 30297 (Atlanta) 5442 Frontage Road, Suite 112 Phone: (404) 608-0006 Fax: (404) 608-1123</p>	<p>ILLINOIS Addison 60101 (Chicago) 311 Laura Drive Phone: (630) 628-6100 Fax: (630) 628-0023</p> <p>Woodridge 60517 (Chicago) 2033 West 75th Street Phone: (630) 910-9200 Fax: (630) 910-0360</p> <p>MARYLAND Elkridge 21075 (Baltimore) 7397-102 Washington Blvd. Phone: (410) 799-9394 Fax: (410) 799-9398</p> <p>MASSACHUSETTS Braintree 02185 (Boston) 719 Granite Street Phone: (781) 848-9810 Fax: (781) 848-6759</p> <p>Franklin 02038 (Boston) Franklin Industrial Park 101E Constitution Blvd. Phone: (608) 520-8802 Fax: (608) 528-8089</p> <p>MICHIGAN Madison Heights 48071 (Detroit) 30475 Stephenson Highway Phone: (248) 597-5000 Fax: (248) 597-5004</p>	<p>MINNESOTA Minneapolis 55429 4315 68th Avenue North Phone: (763) 561-9080 Fax: (763) 561-0653</p> <p>MISSOURI North Kansas City 64116 1141 Swift Avenue P.O. Box 12393 Phone: (816) 221-2070 Fax: (816) 221-2897</p> <p>St. Louis 63119 7574 Watson Road Phone: (314) 968-8950 Fax: (314) 968-2790</p> <p>NEW YORK Flushing 11365-1595 (N.Y.C.) 175-25 Horace Harding Expwy. Phone: (718) 225-2040 Fax: (718) 423-9619</p> <p>NORTH CAROLINA Charlotte 28270 9129 Monroe Road, Suite 115 Phone: (704) 841-1176 Fax: (704) 708-4625</p> <p>OHIO Columbus 43214 4560 Indianola Avenue Phone: (614) 263-0929 Fax: (614) 263-1238</p>	<p>Cleveland 44125 8001 Sweet Valley Drive Unit #19 Phone: (216) 447-9030 Fax: (216) 447-3097</p> <p>OREGON Portland 97230 4916 NE 122 nd Ave. Phone: (503) 252-0107 Fax: (503) 252-2123</p> <p>PENNSYLVANIA Willow Grove 19090 520 North York Road Phone: (215) 658-1430 Fax: (215) 658-1433</p> <p>TEXAS Carrollton 75006 (Dallas) 1300 Interstate 35 N, Suite 112 Phone: (972) 446-2996 Fax: (972) 446-8157</p> <p>Houston 77055 West 10 Business Center 1008 Wirt Road, Suite 120 Phone: (713) 682-0334 Fax: (713) 682-4867</p> <p>WASHINGTON Renton 98055 (Seattle) 268 Southwest 43rd Street Phone: (425) 251-6680 Fax: (425) 251-9337</p>
------------------------------------------------------------------------------------------------------------------------------------------------------------------------------------------------------------------------------------------------------------------------------------------------------------------------------------------------------------------------------------------------------------------------------------------------------------------------------------------------------------------------------------------------------------------------------------------------------------------------------------------------------------------------------------------------------------------------------------------------------------------------------------------------	---------------------------------------------------------------------------------------------------------------------------------------------------------------------------------------------------------------------------------------------------------------------------------------------------------------------------------------------------------------------------------------------------------------------------------------------------------------------------------------------------------------------------------------------------------------------------------------------------------------------------------------------------------------------------------------------------------------------------------------------------------------------------------------------------	------------------------------------------------------------------------------------------------------------------------------------------------------------------------------------------------------------------------------------------------------------------------------------------------------------------------------------------------------------------------------------------------------------------------------------------------------------------------------------------------------------------------------------------------------------------------------------------------------------------------------------------------------------------------------------------------------------------------------------------------------------------------	--------------------------------------------------------------------------------------------------------------------------------------------------------------------------------------------------------------------------------------------------------------------------------------------------------------------------------------------------------------------------------------------------------------------------------------------------------------------------------------------------------------------------------------------------------------------------------------------------------------------------------------------------------------------------------------------------------------------------------------------------------------------------

Authorized Service Stations are located in many large cities. Telephone **800-487-8665** or **731-541-6042** for assistance locating one. Parts and accessories for Porter-Cable • Delta products should be obtained by contacting any Porter-Cable • Delta Distributor, Authorized Service Center, or Porter-Cable • Delta Factory Service Center. If you do not have access to any of these, call **888-848-5175** and you will be directed to the nearest Porter-Cable • Delta Factory Service Center. Las Estaciones de Servicio Autorizadas están ubicadas en muchas grandes ciudades. Llame al **800-487-8665** ó al **731-541-6042** para obtener asistencia a fin de localizar una. Las piezas y los accesorios para los productos Porter-Cable • Delta deben obtenerse poniéndose en contacto con cualquier distribuidor Porter-Cable • Delta, Centro de Servicio Autorizado o Centro de Servicio de Fábrica Porter-Cable • Delta. Si no tiene acceso a ninguna de estas opciones, llame al **888-848-5175** y le dirigirán al Centro de Servicio de Fábrica Porter-Cable • Delta más cercano. Des centres de service agréés sont situés dans beaucoup de grandes villes. Appelez au **800-487-8665** ou au **731-541-6042** pour obtenir de l'aide pour en péter un. Pour obtenir des pièces et accessoires pour les produits Porter-Cable • Delta, s'adresser à tout distributeur Porter-Cable • Delta, centre de service agréé ou centre de service d'usine Porter-Cable • Delta. Si vous n'avez accès à aucun de ces centres, appelez le **888-848-5175** et on vous dirigera vers le centre de service d'usine Porter-Cable • Delta le plus proche.

CANADIAN PORTER-CABLE • DELTA SERVICE CENTERS

<p>ALBERTA Bay 6, 2520-23rd St. N.E. Calgary, Alberta T2E 8L2 Phone: (403) 735-6166 Fax: (403) 735-6144</p> <p>BRITISH COLUMBIA 8520 Baxter Place Burnaby, B.C. V5A 4T8 Phone: (604) 420-0102 Fax: (604) 420-3522</p>	<p>MANITOBA 1699 Dublin Avenue Winnipeg, Manitoba R3H 0H2 Phone: (204) 633-9259 Fax: (204) 632-1976</p> <p>ONTARIO 505 Southgate Drive Guelph, Ontario N1H 6M7 Phone: (519) 836-2840 Fax: (519) 767-4131</p>	<p>QUÉBEC 1515 Ave. St-Jean Baptiste, Québec, Québec G2E 5E2 Phone: (418) 877-7112 Fax: (418) 877-7123</p> <p>1447, Begin St-Laurent, (Montréal), Québec H4R 1V8 Phone: (514) 336-8772 Fax: (514) 336-3505</p>
-----------------------------------------------------------------------------------------------------------------------------------------------------------------------------------------------------------------------------------------------------------------------------	--------------------------------------------------------------------------------------------------------------------------------------------------------------------------------------------------------------------------------------------------------------------	---------------------------------------------------------------------------------------------------------------------------------------------------------------------------------------------------------------------------------------------------------------

The following are trademarks of PORTER-CABLE • DELTA (Las siguientes son marcas registradas de PORTER-CABLE • DELTA S.A.) (Les marques suivantes sont des marques de fabricant de la PORTER-CABLE • DELTA): BAMMER®, LASERLOC®, OMNIJIG®, POCKET CUTTER®, PORTA-BAND®, PORTA-PLANE®, PORTER-CABLE®, QUICKSAND®, SANDTRAP®, SAW BOSS®, SPEED-BLOC®, SPEEDMATIC®, SPEEDTRONIC®, STAIR-EASE®, THE PROFESSIONAL EDGE®, THE PROFESSIONAL SELECT®, TIGER CUB®, TIGER SAW®, TORQ-BUSTER®, VERSA-PLANE®, WHISPER SERIES®, DURATRONIC™, FRAME SAW™, INNOVATION THAT WORKS™, JETSTREAM™, MICRO-SET™, MORTEN™, NETWORK™, RIPTIDE™, TRU-MATCH™, WOODWORKER'S CHOICE™.

Trademarks noted with ® are registered in the United States Patent and Trademark Office and may also be registered in other countries. Las Marcas Registradas con el signo de ® son registradas por la Oficina de Registros y Patentes de los Estados Unidos y también pueden estar registradas en otros países. Marques déposées, indiquées par la lettre ®, sont déposées au Bureau des brevets d'invention et marques déposées aux Etats-Unis et pourraient être déposées aux autres pays.

Printed in U.S.A.

Free Manuals Download Website

<http://myh66.com>

<http://usermanuals.us>

<http://www.somanuals.com>

<http://www.4manuals.cc>

<http://www.manual-lib.com>

<http://www.404manual.com>

<http://www.luxmanual.com>

<http://aubethermostatmanual.com>

Golf course search by state

<http://golfingnear.com>

Email search by domain

<http://emailbydomain.com>

Auto manuals search

<http://auto.somanuals.com>

TV manuals search

<http://tv.somanuals.com>