

PRO-FORM

LOW IMPACT ELLIPTICAL EXERCISER

485€

Model No. PFCCEL87078

Serial No. _____

Write the serial number in the space above for future reference.

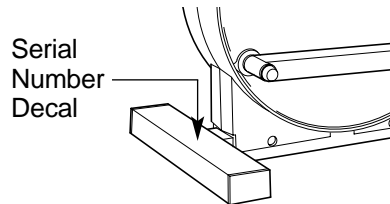

USER'S MANUAL

QUESTIONS?

As a manufacturer, we are committed to providing complete customer satisfaction. If you have questions, or if there are missing parts, we will guarantee complete satisfaction through direct assistance from our factory.

TO AVOID UNNECESSARY DELAYS, PLEASE CALL DIRECT TO OUR TOLL-FREE CUSTOMER HOT LINE. The trained technicians on our customer hot line will provide immediate assistance, free of charge to you.

**CUSTOMER HOT LINE:
1-888-936-4266**

Mon.-Fri., 8:00 a.m.-6:30 p.m.
Eastern Standard Time
(excluding holidays)



Patent Pending

CAUTION

Read all precautions and instructions in this manual before using this equipment. Keep this manual for future reference.



Visit our website at

www.proform.com

*new products, prizes,
fitness tips, and much more!*



TABLE OF CONTENTS

IMPORTANT PRECAUTIONS3
BEFORE YOU BEGIN4
PART IDENTIFICATION CHART5
ASSEMBLY6
HOW TO USE THE ELLIPTICAL EXERCISER9
MAINTENANCE11
CONDITIONING GUIDELINES12
PART LIST14
EXPLODED DRAWING15
ORDERING REPLACEMENT PARTS19
LIMITED WARRANTYBack Cover

IMPORTANT PRECAUTIONS

WARNING: To reduce the risk of serious injury, read the following important precautions before using the PROFORM® 485E.

1. Read all instructions in this manual before using the elliptical exerciser.
2. Use the elliptical exerciser only as described in this manual.
3. It is the responsibility of the owner to ensure that all users of the elliptical exerciser are adequately informed of all precautions.
4. Place the elliptical exerciser on a level surface, with a mat beneath it to protect the floor or carpet. Keep the elliptical exerciser indoors, away from moisture and dust.
5. Inspect and tighten all parts regularly. Replace any worn parts immediately.
6. Keep children under the age of 12 and pets away from the elliptical exerciser at all times.
7. The elliptical exerciser should not be used by persons weighing more than 250 pounds.
8. Wear appropriate clothing when using the elliptical exerciser. Always wear athletic shoes for foot protection.
9. When mounting and dismounting the elliptical exerciser, always hold the handlebars or the T-handle and step onto and off the pedal that is in the lowest position.
10. Each time you stop exercising on the elliptical exerciser, allow the pedals to come to a complete stop before dismounting.
11. Always keep your back straight when using the elliptical exerciser. Do not arch your back.
12. If you feel pain or dizziness at any time while exercising, stop immediately and begin cooling down.
13. The elliptical exerciser is intended for in-home use only. Do not use the elliptical exerciser in a commercial, rental, or institutional setting.

WARNING: Before beginning this or any exercise program, consult your physician. This is especially important for persons over the age of 35 or persons with pre-existing health problems. Read all instructions before using. ICON assumes no responsibility for personal injury or property damage sustained by or through the use of this product.

The decal shown at the right has been placed on the elliptical exerciser. If the decal is missing, or if it is not legible, please call our Customer Service Department at 1-888-936-4266 to order a free replacement decal. Apply the decal in the location shown.

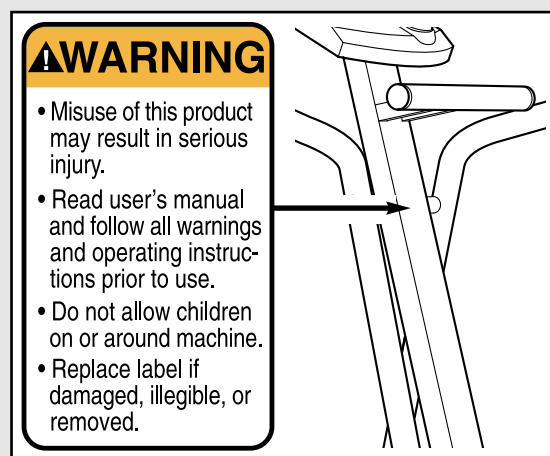

BEFORE YOU BEGIN

Congratulations for selecting the PROFORM® 485E low-impact elliptical exerciser. The PROFORM® 485E is an incredibly smooth exerciser that moves your feet in a natural elliptical path, minimizing the impact on your knees and ankles. And the unique PROFORM® 485E features adjustable resistance, upper-body and stationary handlebars, and a multi-mode exercise monitor to help you get the most from your exercise. Welcome to a whole new world of natural, elliptical-motion exercise from PROFORM.

For your benefit, read this manual carefully before you use the PROFORM® 485E. If you have questions

after reading the manual, call our Customer Service Department toll-free at 1-888-936-4266, Monday through Friday, 8:00 a.m. to 6:30 p.m. Eastern Standard Time (excluding holidays). To help us assist you, please note the product model number and serial number before calling. The model number is PFCCEL87078. The serial number can be found on a decal attached to the elliptical exerciser (see the front cover of this manual for the location of the decal).



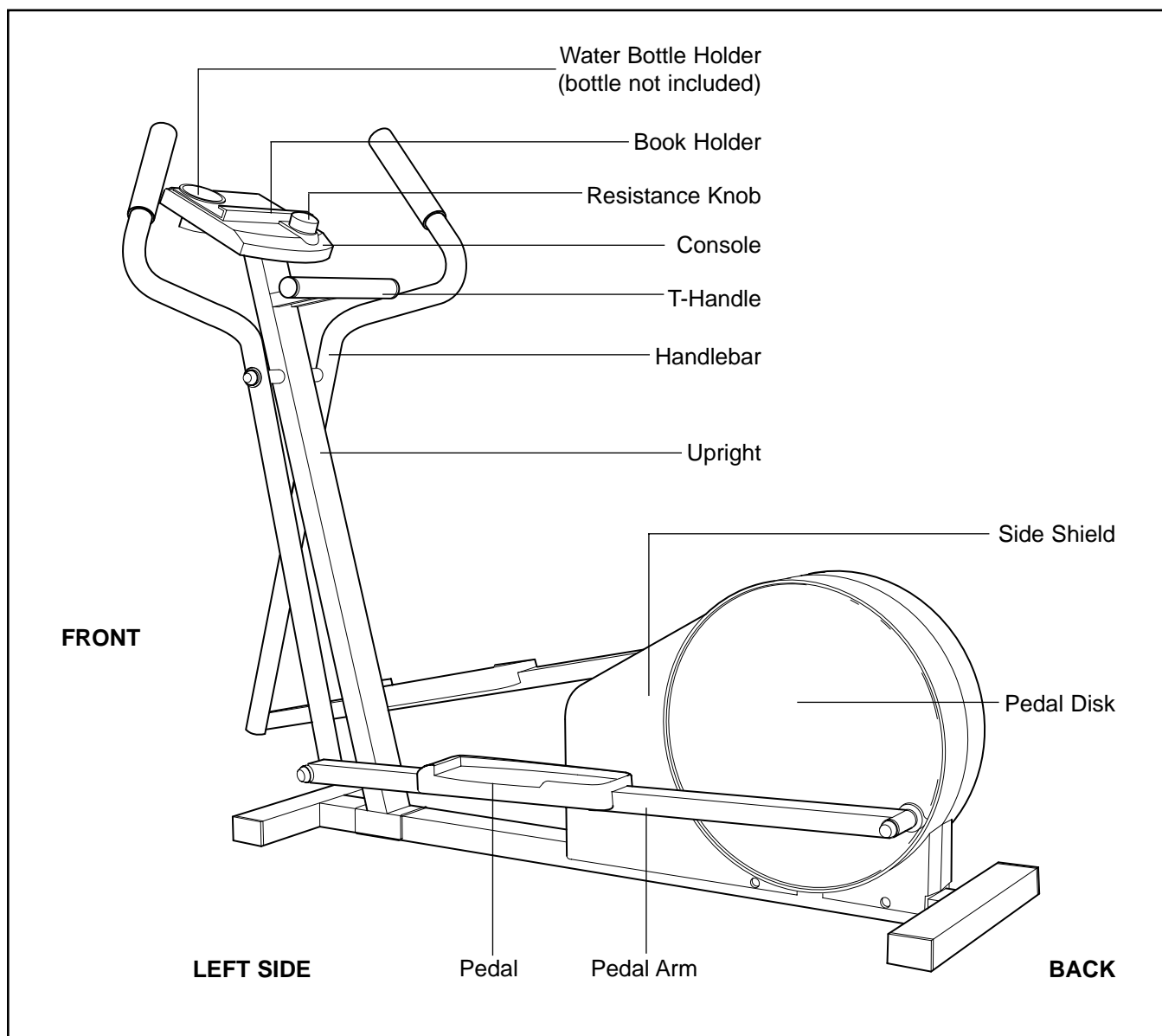





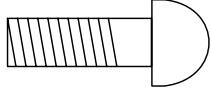

Before reading further, please look at the drawing below and familiarize yourself with the parts that are labeled.

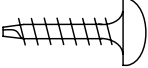

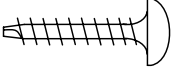
PART IDENTIFICATION CHART

Use the chart below to identify the small parts used in assembly. The number in parenthesis below each part refers to the key number of the part, from the PART LIST on page 14. The number after the dash indicates

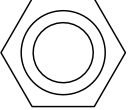
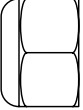
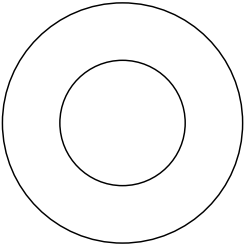

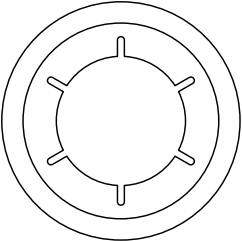
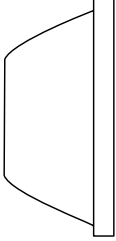
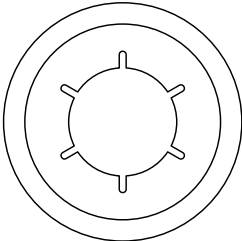
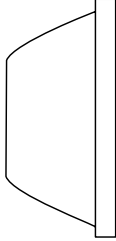
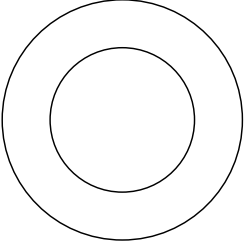
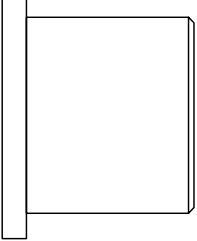
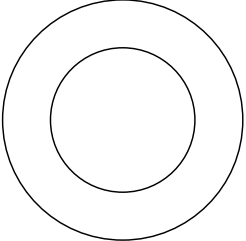
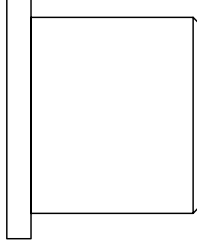
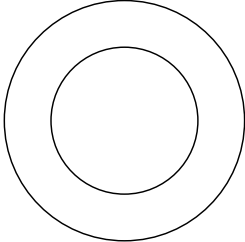
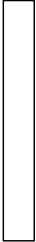
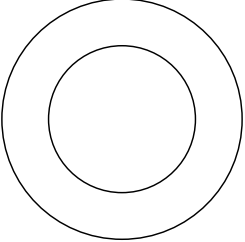
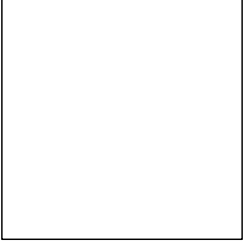
the quantity needed for assembly. **Note: Some parts may have been pre-attached for shipping. If a part is not in the parts bag, check to see if it has been pre-attached.**

					
M6 x 16mm Button Head Bolt (54)—2		M4 x 16mm Round Head Screw (38)—4		M4 x 19mm Round Head Screw (16)—6	
					
	M6 Black Nylon Locknut (55)—2		M10 Nylon Locknut (29)—4		
					
Weld Spacer (49)—2		3/4" Axle Cap (43)—4*		5/8" Axle Cap (57)—2*	
					
Pedal Arm Bushing (42)—4		Rear Pedal Arm Bushing (11)—4			
					
Handlebar Spacer (39)—2		Pedal Arm Spacer (41)—2*			

* Extra parts may be included.

ASSEMBLY

Assembly requires two people. Place all parts of the elliptical exerciser in a cleared area and remove the packing materials. Do not dispose of the packing materials until assembly is completed.

Assembly requires a phillips screwdriver , **two adjustable wrenches** , and a **rubber mallet** .

1. While another person holds the Upright (3) near the Frame (1) as shown, gently pull the Resistance Cable (26) and the Sensor Wire (25) out of the top of the Upright until there is no slack between the Upright and the Frame.

Slide the Upright (3) onto the welded bolts on the Frame (1). **Be careful to avoid pinching the Resistance Cable (26) and the Sensor Wire (25).** Tighten an M10 Nylon Locknut (29) onto each welded bolt.

2. While another person holds the Console (6) near the Upright (3), connect the console wire to the Sensor Wire (25).

Feed the slack Sensor Wire (25) back down into the Upright (3). Attach the Console (6) to the Upright (3) with four M4 x 16mm Round Head Screws (38). **Be careful to avoid pinching the Sensor Wire.**

Press the Resistance Control Knob (50) onto the Resistance Control (26).

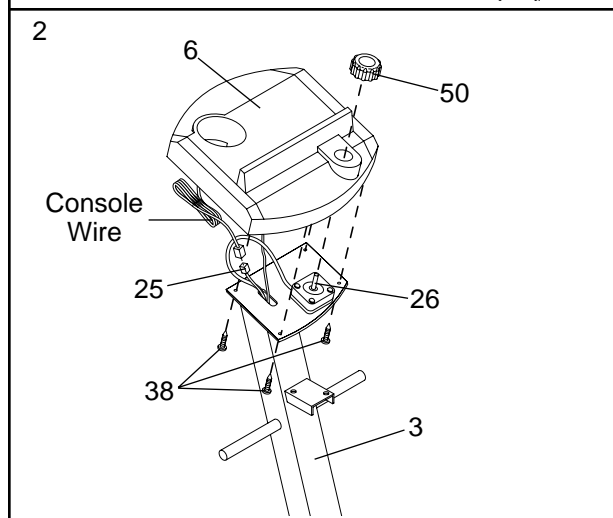
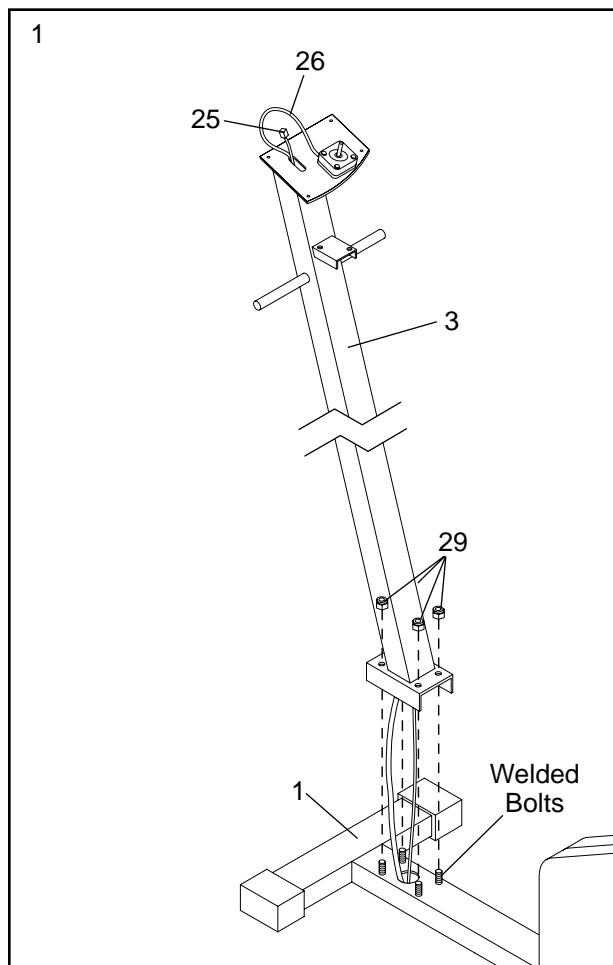

- Find the Left Pedal (31), which has a ridge on the right side. Attach the Left Pedal to one of the Pedal Arms (12) with three M4 x 19mm Round Head Screws (16) as shown.

Repeat this step to attach the Right Pedal to the other Pedal Arm (not shown).

- Identify the Left Handlebar (8) (there is an "L" sticker on the Left Handlebar). Apply a thin film of the included grease to the axle on the Left Handlebar.

Make sure that there are two Pedal Arm Bushings (42) in each Pedal Arm (12).

Slide a Handlebar Spacer (39) and the Pedal Arm (12) with the Left Pedal (31) onto the Left Handlebar (8) as shown. (Note: These parts fit tightly; it may be helpful to use the rubber mallet.) Next, refer to the PART IDENTIFICATION CHART on page 5 and identify the 3/4" Axle Caps (43). Tap a 3/4" Axle Cap onto the Left Handlebar.

Repeat this step to attach the other Pedal Arm (12) to the Right Handlebar (62).

- Apply a thin film of the included grease to the axles on the Upright (3). Slide a Weld Spacer (49) onto the left axle on the Upright. Make sure that the open side of the Weld Spacer is facing the Upright.

Slide a Pedal Arm Spacer (41) onto the left Crank Arm (59).

Make sure that there are two Rear Pedal Arm Bushings (11) in the Pedal Arm (12) attached to the Left Handlebar (8).

With the help of another person, slide the Left Handlebar (8) onto the left axle on the Upright (3) while sliding the left Pedal Arm (12) onto the left Crank Arm (59). (Note: These parts fit tightly; it may be helpful to use the rubber mallet. In addition, it may be helpful to rotate the left Crank Arm (59) to a different position.)

Tap a 5/8" Axle Cap (57) onto the left axle on the Upright (3).

Tap a 3/4" Axle Cap (43) onto the left Crank Arm (59).

Repeat this step to attach the Right Handlebar and the right Pedal Arm (not shown).

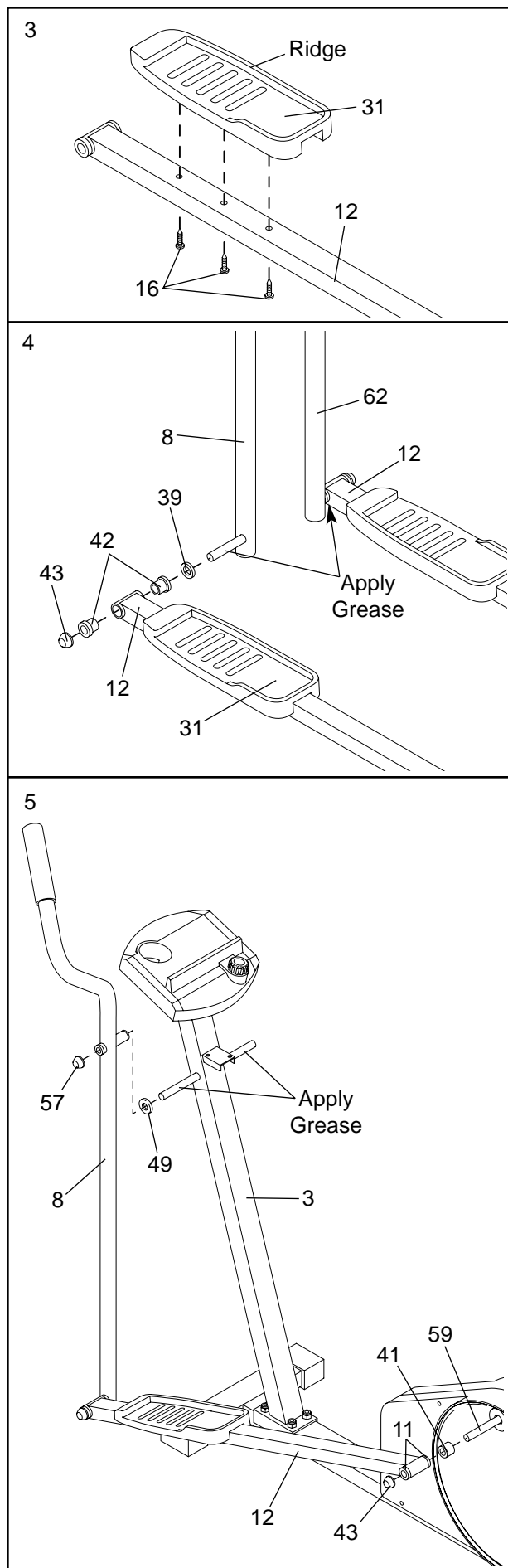

6. Attach the T-Handle (10) to the Upright (3) with two M6 x 16mm Button Head Bolts (54) and two M6 Black Nylon Locknuts (55).

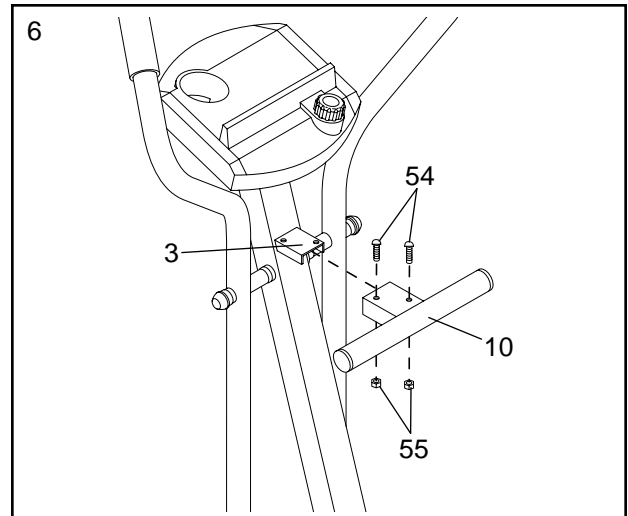

7. The Console (6) requires two "AA" batteries (not included). Alkaline batteries are recommended.

To install batteries, first locate the battery clip under the Console (6). Insert two batteries into the battery clip as shown. **Make sure that the batteries are turned so the negative ends of the batteries (marked "-") are touching the springs in the battery clip.**

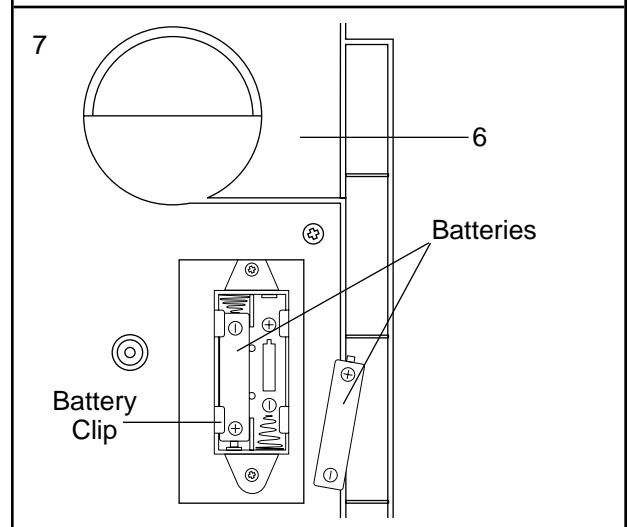

8. **Make sure that all parts are properly tightened before you use the elliptical exerciser.** Note: There may be some hardware left over after assembly is complete. Place a mat under the elliptical exerciser to protect the floor or carpet from damage.

HOW TO USE THE ELLIPTICAL EXERCISER

HOW TO EXERCISE ON THE ELLIPTICAL EXERCISER

To mount the elliptical exerciser, firmly hold the handlebars or the T-handle and carefully step onto the pedal that is in the lowest position. Next, step onto the other pedal. Push the pedals until they begin to move with a continuous motion. **Note: The pedal disks can turn in either direction; it is recommended that you turn the pedal disks in the direction shown below; however, to give variety to your exercise, you may choose to turn the pedal disks in the opposite direction.**

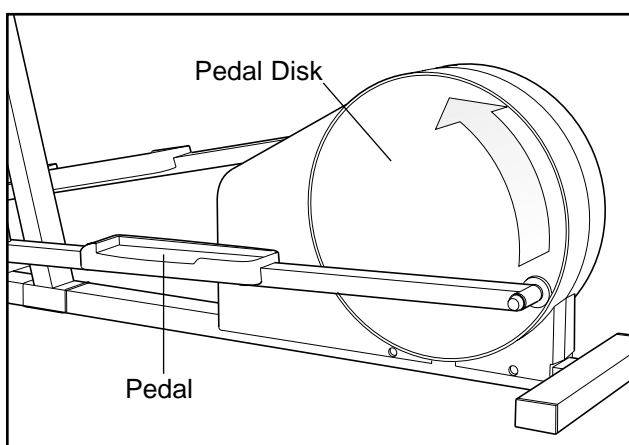

To dismount the elliptical exerciser, allow the pedals to come to a complete stop. **CAUTION: The elliptical exerciser does not have a freewheel; the pedals will continue to move until the flywheel stops.** When the pedals are stationary, step off the highest pedal first. Then, step off the lowest pedal.

HOW TO ADJUST THE RESISTANCE OF THE PEDALS

As you exercise, you can adjust the resistance of the pedals with the resistance knob on the console. To increase the resistance, turn the knob clockwise; to decrease the resistance, turn the knob counterclockwise.

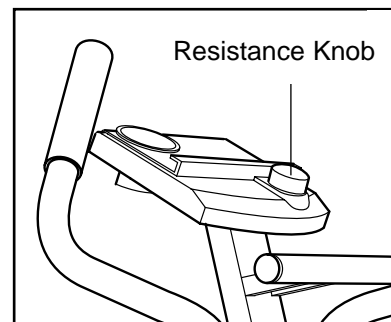

DESCRIPTION OF THE CONSOLE

The console is designed to help you get the most from your workouts. As you exercise, you can watch your progress around the LED track, while the display provides continuous exercise feedback. The six modes of the display are described below.

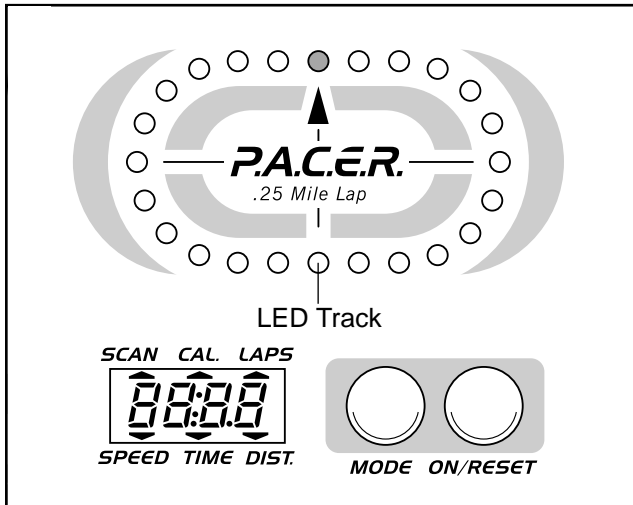

SPEED—This mode displays your current exercise speed, in miles per hour.

TIME—This mode displays the length of time you have exercised. Note: If you stop exercising, the time mode will pause until you resume.

DIST.—This mode displays the total distance you have completed, in miles.

LAPS—This mode displays the number of 1/4-mile laps you have completed around the LED track.

CAL.—This mode displays the approximate number of Calories you have burned.

SCAN—This mode displays the speed, time, distance, laps, and calorie modes, for 5 seconds each, in a repeating cycle.

BATTERY INSTALLATION

Before the console can be operated, two "AA" batteries must be installed. If you have not installed batteries, see assembly step 7 on page 8.

HOW TO OPERATE THE CONSOLE

If there is a thin sheet of clear plastic on the face of the console, remove it.

1. To turn on the power, press the "on/reset" button or simply begin exercising. When the power is turned on, one LED indicator will light in the LED track, and the entire display will appear for two seconds. The console will then be ready for operation.
2. Select one of the six modes:

Scan mode—When the power is turned on, the scan mode will automatically be selected. One mode indicator will show that the scan mode is selected, and a flashing mode indicator will show which mode is currently displayed. Note: If a different mode is selected, you can select the scan mode again by repeatedly pressing the mode button.

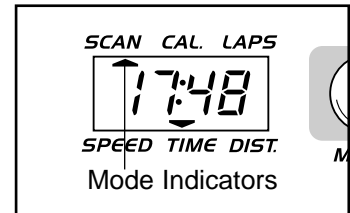

Speed, Time, Distance, Laps, or Calorie mode—To select one of these modes for continuous display, press the mode button repeatedly. The mode indicators will show which mode is selected. (Make sure that the scan mode is not selected.)

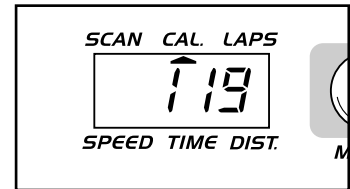

3. The LED track represents a distance of 1/4 mile. As you exercise, the indicators around the track will light one at a time until you have completed 1/4 mile. A new lap will then begin.
4. To reset the display, press the "on/reset" button.
5. To turn off the power, simply wait for about four minutes. **Note: The console has an "auto-off" feature. If the pedals are not moved and the console buttons are not pressed for four minutes, the power will turn off automatically in order to conserve the batteries.**

MAINTENANCE

Inspect and tighten all parts of the elliptical exerciser regularly. Replace any worn parts immediately.

The elliptical exerciser can be wiped clean with a soft cloth and mild detergent. **Do not use abrasives or solvents.** To prevent damage to the console, keep liquids away from the console. Use only a sealable water bottle in the console.

CONSOLE TROUBLE-SHOOTING

If the console does not function properly, the batteries should be replaced. To replace the batteries, refer to assembly step 7 on page 8.

STORAGE

When storing the elliptical exerciser, remove the batteries from the console. Keep the elliptical exerciser in a clean, dry location, away from moisture and dust.

CONDITIONING GUIDELINES

The following guidelines will help you to plan your exercise program. Remember that proper nutrition and adequate rest are essential for successful results.

WARNING: Before beginning this or any exercise program, consult your physician. This is especially important for persons over the age of 35 or persons with pre-existing health problems.

EXERCISE INTENSITY

Whether your goal is to burn fat or to strengthen your cardiovascular system, the key to achieving the desired results is to exercise with the proper intensity. The proper intensity level can be found by using your heart rate as a guide. The chart below shows recommended heart rates for fat burning, maximum fat burning, and cardiovascular (aerobic) exercise.

HEART RATE TRAINING ZONES								
MIN ♥	125	120	115	110	105	95	90	Fat Burn
BPM	145	138	130	125	118	110	103	Max Burn
MAX ♥	165	155	145	140	130	125	115	Aerobic
AGE	20	30	40	50	60	70	80	

To find the proper heart rate for you, first find your age at the bottom of the chart (ages are rounded off to the nearest ten years). Next, find the three numbers above your age. The three numbers are your “training zone.” The smallest number is the recommended heart rate for fat burning; the middle number is the heart rate for maximum fat burning; the largest number is the heart rate for aerobic exercise.

Burning Fat

To burn fat effectively, you must exercise at a relatively low intensity level for a sustained period of time. During the first few minutes of exercise, your body

uses easily accessible *carbohydrate* calories for energy. Only after the first few minutes of exercise does your body begin to use stored *fat* calories for energy. If your goal is to burn fat, adjust the intensity of your exercise until your heart rate is near the smallest number in your training zone as you exercise.

For maximum fat burning, adjust the intensity of your exercise until your heart rate is near the middle number in your training zone as you exercise.

Aerobic Exercise

If your goal is to strengthen your cardiovascular system, your exercise must be “aerobic.” Aerobic exercise is activity that requires large amounts of oxygen for prolonged periods of time. This increases the demand on the heart to pump blood to the muscles, and on the lungs to oxygenate the blood. For aerobic exercise, adjust the intensity of your exercise until your heart rate is near the largest number in your training zone.

HOW TO MEASURE YOUR HEART RATE

To measure your heart rate, first exercise for at least four minutes. Then, stop exercising and place two fingers on your wrist as shown.

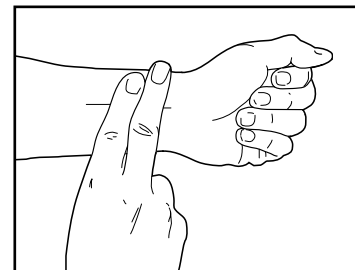

Take a six-second heartbeat count, and multiply the result by 10 to find your heart rate. For example, if your six-second heartbeat count is 14, your heart rate is 140 beats per minute. (A six-second count is used because your heart rate will drop rapidly when you stop exercising.)

WORKOUT GUIDELINES

Each workout should include the following three important parts:

A warm-up, consisting of 5 to 10 minutes of stretching and light exercise. (See page 13.) A proper warm-up increases your body temperature, heart rate, and circulation in preparation for exercise.

Training zone exercise, consisting of 20 to 30 minutes of exercising with your heart rate in your training zone. (During the first few weeks of your exercise program, do not keep your heart rate in your training zone for longer than 20 minutes.)

A cool-down, with 5 to 10 minutes of stretching. This will increase the flexibility of your muscles and will help to prevent post-exercise problems.

EXERCISE FREQUENCY

To maintain or improve your condition, plan three workouts each week, with at least one day of rest between workouts. After a few months of regular exercise, you may plan up to five workouts each week, if desired.

Caution: Be sure to progress at your own pace and avoid overdoing it. Incorrect or excessive training may result in injury to your health.

Remember, the key to success is make exercise a regular and enjoyable part of your everyday life.

SUGGESTED STRETCHES

The correct form for several basic stretches is shown at the right. Move slowly as you stretch—never bounce.

1. Toe Touch Stretch

Stand with your knees bent slightly and slowly bend forward from your hips. Allow your back and shoulders to relax as you reach down toward your toes as far as possible. Hold for 15 counts, then relax. Repeat 3 times. Stretches: Hamstrings, back of knees, and back.

2. Hamstring Stretch

Sit with one leg extended. Bring the sole of the opposite foot toward you and rest it against the inner thigh of your extended leg. Reach toward your toes as far as possible. Hold for 15 counts, then relax. Repeat 3 times for each leg. Stretches: Hamstrings, lower back, and groin.

3. Calf/Achilles Stretch

With one leg in front of the other, reach forward and place your hands against a wall. Keep your back leg straight and your back foot flat on the floor. Bend your front leg, lean forward and move your hips toward the wall. Hold for 15 counts, then relax. Repeat 3 times for each leg. To cause further stretching of the achilles tendons, bend your back leg as well. Stretches: Calves, achilles tendons, and ankles.

4. Quadriceps Stretch

With one hand against a wall for balance, reach back and grasp one foot with your other hand. Bring your heel as close to your buttocks as possible. Hold for 15 counts, then relax. Repeat 3 times for each leg. Stretches: Quadriceps and hip muscles.

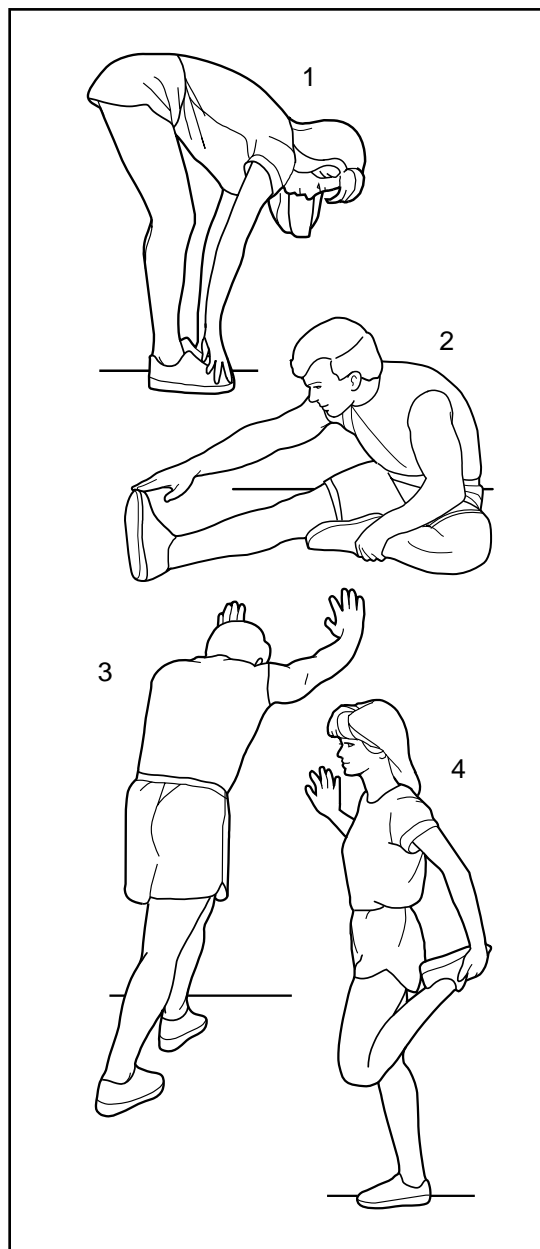

PART LIST—Model No. PFCCEL87078

R1299A

Key No.	Qty.	Description	Key No.	Qty.	Description
1	1	Frame	34	1	M4 x 16mm Screw
2	2	T-Handle Endcap	35	2	5/16" Zinc Bolt
3	1	Upright	36	2	Pulley Bearing
4	1	Right Side Shield	37	2	Pedal Disk
5	1	Left Side Shield	38	10	M4 x 16mm Round Head Screw
6	1	Console	39	2	Handlebar Spacer
7	2	Foam Handlebar Grip	40	1	Side Shield Bracket
8	1	Left Handlebar	41	2*	Pedal Arm Spacer
9	2	M8 Lock Washer	42	4	Pedal Arm Bushing
10	1	T-Handle	43	4*	3/4" Axle Cap
11	4	Rear Pedal Arm Bushing	44	1	M4 x 16mm Flat Head Screw
12	2	Pedal Arm	45	1	Right Pedal
13	14	M5 x 16mm Screw	46	4	#8 Flat Washer
14	1	Resistance Strap	47	1	Clamp Nut
15	1	Strap Buckle	48	1	Clamp Bolt
16	6	M4 x 19mm Round Head Screw	49	2	Weld Spacer
17	2	1/4" Nylon Locknut	50	1	Resistance Control Knob
18	2	Adjustment Bracket	51	4	M5 x 25mm Screw
19	2	M6 Eyebolt	52	1	Return Spring
20	2	M10 Nylon Jam Nut	53	2	M10 Washer
21	1	Flywheel Axle	54	2	M6 x 16mm Button Head Bolt
22	2	Flywheel Bearing	55	2	M6 Black Nylon Locknut
23	1	Flywheel	56	4*	Pivot Bushing
24	1	Magnet	57	2*	5/8" Axle Cap
25	1	Sensor Wire/Reed Switch	58	1	M4 x 64mm Screw
26	1	Resistance Control/Cable	59	2	Crank Arm
27	4	Stabilizer Endcap	60	1	3/4" Plastic Spacer
28	1	Tension Spring	61	2	5/16" Zinc Washer
29	4	M10 Nylon Locknut	62	1	Right Handlebar
30	1	Belt	#	1	User's Manual
31	1	Left Pedal	#	2	Side Shield Decal
32	1	Pulley w/Shaft	#	1	Warning Decal
33	2	Crank Arm Extension	#	1	Hardware Kit

Note: “#” indicates a non-illustrated part. “*” indicates that an extra part may be included. Specifications are subject to change without notice. See the back cover of this manual for information about ordering replacement parts.

CUSTOMER RECORD

Model No.: _____ Serial No.: _____

Retailer Name: _____ Purchase Date: _____

Retailer Address: _____

NOTES

NOTES

ORDERING REPLACEMENT PARTS

To order replacement parts, simply call our Customer Service Department toll-free at 1-888-936-4266, Monday through Friday, 8:00 a.m. 6:30 p.m. Eastern Standard Time (excluding holidays). To help us assist you, please be prepared to give the following information when calling:

- The MODEL NUMBER of the product (PCCEL87078)
- The NAME of the product (PROFORM® 485E elliptical exerciser)
- The SERIAL NUMBER of the product (see the front cover of this manual)
- The KEY NUMBER and the DESCRIPTION of the part(s) (see PART LIST on page 14 of this manual).

**PLACE
STAMP
HERE**

ICON of Canada Inc.
900 de l'Industrie
St-Jérôme, Québec
Canada, J7Y 4B8

LIMITED WARRANTY

ICON OF/DU CANADA INC., (ICON), warrants this product to be free from defects in workmanship and material, under normal use and service conditions, for a period of ninety (90) days from the date of purchase. This warranty extends only to the original purchaser. ICON's obligation under this warranty is limited to replacing or repairing, at ICON's option, the product at one of its authorized service centers. All products for which warranty claim is made must be received by ICON at one of its authorized service centers with all freight and other transportation charges prepaid, accompanied by sufficient proof of purchase. All returns must be pre-authorized by ICON. This warranty does not extend to any product or damage to a product caused by or attributable to freight damage, abuse, misuse, improper or abnormal usage or repairs not provided by an ICON authorized service center, to products used for commercial or rental purposes, or to products used as store display models. No other warranty beyond that specifically set forth above is authorized by ICON.

ICON is not responsible or liable for indirect, special or consequential damages arising out of or in connection with the use or performance of the product or damages with respect to any economic loss, loss of property, loss of revenues or profits, loss of enjoyment or use, costs of removal, installation or other consequential damages of whatsoever nature. Some provinces do not allow the exclusion or limitation of incidental or consequential damages. Accordingly, the above limitation may not apply to you. The warranty extended hereunder is in lieu of any and all other warranties and any implied warranties of merchantability or fitness for a particular purpose is limited in its scope and duration to the terms set forth herein. Some provinces do not allow limitations on how long an implied warranty lasts. Accordingly, the above limitation may not apply to you.

This warranty gives you specific legal rights. You may also have other rights which vary from province to province or so specified by the retailer of your equipment.

ICON OF/DU CANADA, 900 de l'Industrie, St. Jerôme, QC J7Y 4B8

 WEIDER PRO-FORM WESLO		PRODUCT WARRANTY REGISTRATION	
IMPORTANT: MAIL WITHIN 14 DAYS OF PURCHASE			
NAME: _____		PHONE: _____	
ADDRESS: _____			
COUNTY: _____		POSTCODE: _____	
MODEL NO.: _____		SERIAL NO.: _____	PURCHASE DATE: _____
RETAILER NAME: _____		RETAILER ADDRESS: _____	
1) Primary user(s) of product: <input type="checkbox"/> Male <input type="checkbox"/> Female <input type="checkbox"/> Family	2) Age of primary user: <input type="checkbox"/> 0-24 <input type="checkbox"/> 35-44 <input type="checkbox"/> 55-64 <input type="checkbox"/> 25-34 <input type="checkbox"/> 45-54 <input type="checkbox"/> 65 and over	8) Did you consider purchasing fitness equipment from another manufacturer? <input type="checkbox"/> No <input type="checkbox"/> Yes What other Manufacturer? _____	
3) Annual household income: <input type="checkbox"/> 0-9,999 <input type="checkbox"/> 15,000-19,999 <input type="checkbox"/> 10,000-14,999 <input type="checkbox"/> 20,000+	4) How many times a week do you exercise? <input type="checkbox"/> Less than 3 times <input type="checkbox"/> 3 times or more	9) Based on your impression of what you have purchased, would you buy another ICON product? <input type="checkbox"/> Yes <input type="checkbox"/> No <input type="checkbox"/> No Opinion If not, what other brand name equipment would you purchase? _____	
5) Have you ever purchased an ICON product before? <input type="checkbox"/> Yes <input type="checkbox"/> No	6) Where did you first see or hear about ICON products? <input type="checkbox"/> Magazine <input type="checkbox"/> Friend/relative <input type="checkbox"/> Newspaper Ad <input type="checkbox"/> Store <input type="checkbox"/> Other	10) What other type of exercise equipment do you own? <input type="checkbox"/> Bicycle <input type="checkbox"/> Exercise Cycle <input type="checkbox"/> Treadmill <input type="checkbox"/> Home Gym <input type="checkbox"/> Weight Bench <input type="checkbox"/> Stepper <input type="checkbox"/> Cardio Glide <input type="checkbox"/> Other	
7) What was the primary reason for purchasing this ICON product? <input type="checkbox"/> Store Employee <input type="checkbox"/> Television Ads <input type="checkbox"/> Colour <input type="checkbox"/> Electronic Features <input type="checkbox"/> Magazine Ads <input type="checkbox"/> Price <input type="checkbox"/> Product Design <input type="checkbox"/> Product Innovation <input type="checkbox"/> Other Features	11) Which type of magazines do you read regularly? <input type="checkbox"/> Sports <input type="checkbox"/> Fitness <input type="checkbox"/> Motoring <input type="checkbox"/> Business <input type="checkbox"/> Computer <input type="checkbox"/> General	12) Do you wish to be sent further bulletins about ICON products? <input type="checkbox"/> Yes <input type="checkbox"/> No	
THANK YOU FOR YOUR TIME			
© 1999 ICON of Canada, Inc. Printed in China			

PROFORM is a registered trademark of ICON Health & Fitness, Inc.

Free Manuals Download Website

<http://myh66.com>

<http://usermanuals.us>

<http://www.somanuals.com>

<http://www.4manuals.cc>

<http://www.manual-lib.com>

<http://www.404manual.com>

<http://www.luxmanual.com>

<http://aubethermostatmanual.com>

Golf course search by state

<http://golfingnear.com>

Email search by domain

<http://emailbydomain.com>

Auto manuals search

<http://auto.somanuals.com>

TV manuals search

<http://tv.somanuals.com>