

PRO-FORM® STRIDE SELECT 830

Model No. PFEL3926.0

Serial No. _____

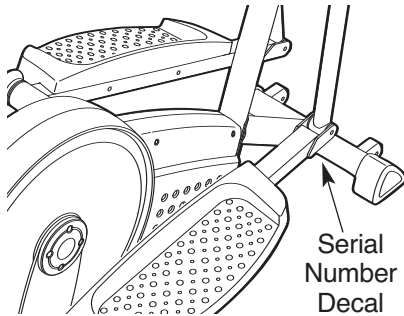

USER'S MANUAL

QUESTIONS?

As a manufacturer, we are committed to providing complete customer satisfaction. If you have questions, or if parts are damaged or missing, PLEASE CONTACT OUR CUSTOMER SERVICE DEPARTMENT DIRECTLY.

CALL TOLL-FREE:

1-888-533-1333

Mon.–Fri., 6 a.m.–6 p.m. MST

Sat. 8 a.m.–5 p.m. MST

ON THE WEB:

www.proformservice.com

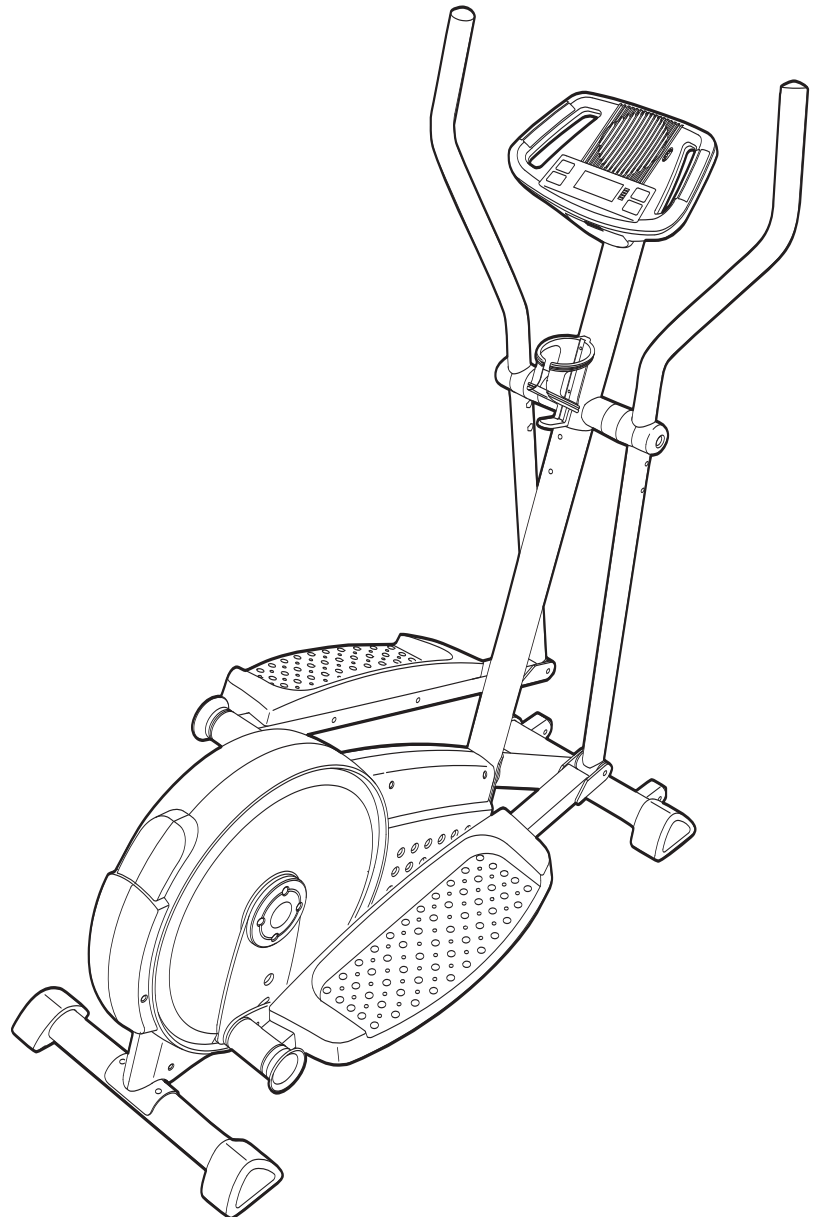

⚠ CAUTION

Read all precautions and instructions in this manual before using this equipment. Keep this manual for future reference.



Visit our website at

www.proform.com

new products, prizes,
fitness tips, and much more!

PRO-FORM[®]

STRIDE SELECT 830

TABLE OF CONTENTS

IMPORTANT PRECAUTIONS	3
BEFORE YOU BEGIN	4
ASSEMBLY	5
HOW TO USE THE ELLIPTICAL EXERCISER	11
MAINTENANCE AND TROUBLESHOOTING	17
CONDITIONING GUIDELINES	18
PART LIST	21
EXPLODED DRAWING	22
ORDERING REPLACEMENT PARTS	Back Cover
LIMITED WARRANTY	Back Cover

IMPORTANT PRECAUTIONS

⚠ WARNING: To reduce the risk of serious injury, read the following important precautions before using the elliptical exerciser.

1. Read all instructions in this manual and all warnings on the elliptical exerciser before using the elliptical exerciser. Use the elliptical exerciser only as described in this manual.
2. It is the responsibility of the owner to ensure that all users of the elliptical exerciser are adequately informed of all precautions.
3. The elliptical exerciser is intended for home use only. Do not use the elliptical exerciser in a commercial, rental, or institutional setting.
4. Keep the elliptical exerciser indoors, away from moisture and dust. Place the elliptical exerciser on a level surface, with a mat beneath it to protect the floor or carpet. Make sure that there is enough clearance around the elliptical exerciser to mount, dismount, and use it.
5. Inspect and properly tighten all parts regularly. Replace any worn parts immediately.
6. Keep children under age 12 and pets away from the elliptical exerciser at all times.
7. The elliptical exerciser should not be used by persons weighing more than 250 lbs. (113 kg).
8. Wear appropriate exercise clothes while using the elliptical exerciser. Always wear athletic shoes for foot protection while exercising.
9. Hold the handgrip pulse sensor or the handlebars when mounting, dismounting, or using the elliptical exerciser.
10. The pulse sensor is not a medical device. Various factors may affect the accuracy of heart rate readings. The pulse sensor is intended only as an exercise aid in determining heart rate trends in general.
11. Keep your back straight while using the elliptical exerciser; do not arch your back.
12. If you feel pain or dizziness while exercising, stop immediately and cool down.
13. When you stop exercising, allow the pedals to slowly come to a stop.
14. The decal shown below has been placed on the elliptical exerciser. If the decal is missing, or if it is not legible, call the toll-free telephone number on the front cover of this manual and order a free replacement decal. Apply the decal in the location shown.

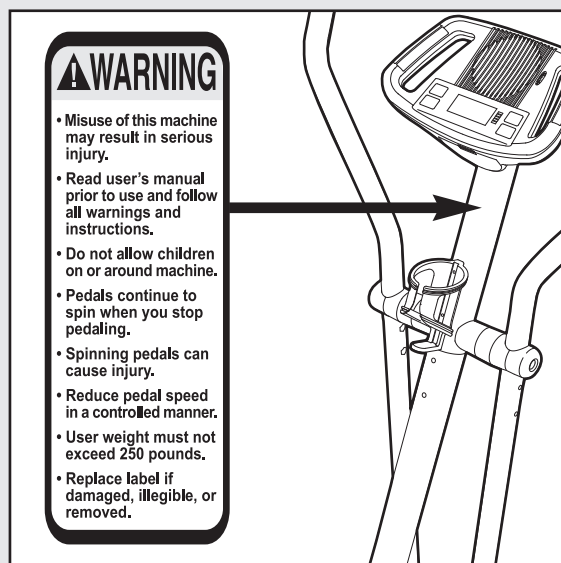

⚠ WARNING: Before beginning this or any exercise program, consult your physician. This is especially important for persons over the age of 35 or persons with pre-existing health problems. Read all instructions before using. ICON assumes no responsibility for personal injury or property damage sustained by or through the use of this product.

BEFORE YOU BEGIN

Congratulations for selecting the versatile new PROFORM® STRIDE SELECT 830 elliptical exerciser. The STRIDE SELECT 830 is an incredibly smooth exerciser that moves your feet in a natural elliptical path, minimizing the impact on your knees and ankles. And the unique STRIDE SELECT 830 offers an impressive array of features to help you achieve your fitness goals in the convenience of your home.

For your benefit, read this manual carefully before you use the elliptical exerciser. If you have questions after reading this manual, please see the front cover of this manual. To help us assist you, note the

product model number and serial number before contacting us. The model number is PFEL3926.0. The serial number can be found on a decal attached to the elliptical exerciser (see the front cover of this manual for the location of the decal).

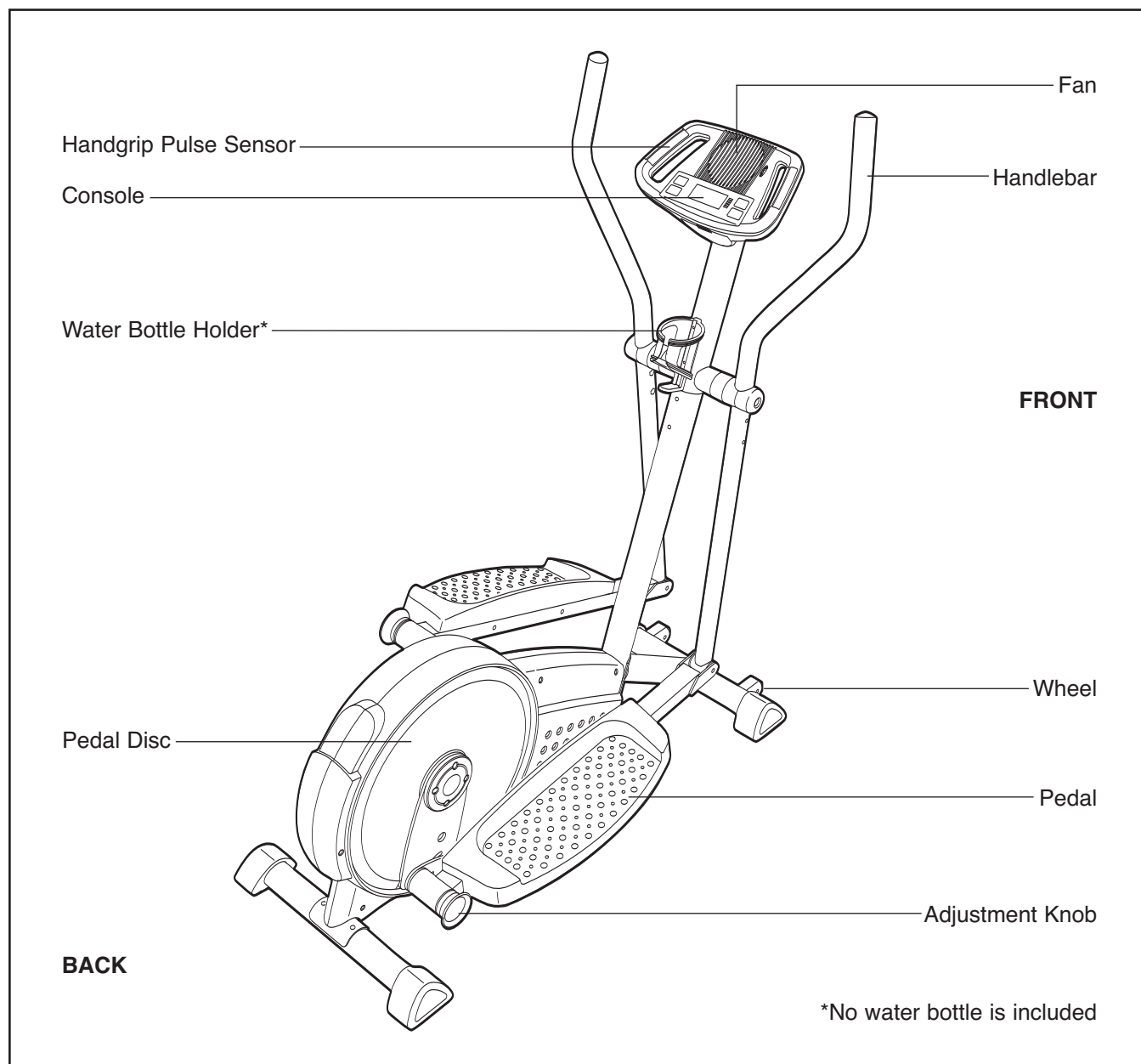

To avoid a registration fee for any service needed under warranty, you must register the elliptical exerciser at www.proformservice.com/registration.

Before reading further, please familiarize yourself with the parts that are labeled in the drawing below.



ASSEMBLY

To hire an authorized service technician to assemble the elliptical exerciser, call toll-free 1-800-445-2480.

Assembly requires two persons. Place all parts of the elliptical exerciser in a cleared area and remove the packing materials. Do not dispose of the packing materials until assembly is completed. **In addition to the included hex keys, assembly requires a phillips screwdriver** , **an adjustable wrench** , **and a rubber mallet** .

As you assemble the elliptical exerciser, use the drawings below to identify small parts. The number in parentheses below each drawing is the key number of the part, from the PART LIST on page 21. The number following the parentheses is the quantity needed for assembly. **Note: Some small parts may have been preassembled. If a part is not in the parts bag, check to see if it has been preassembled.**

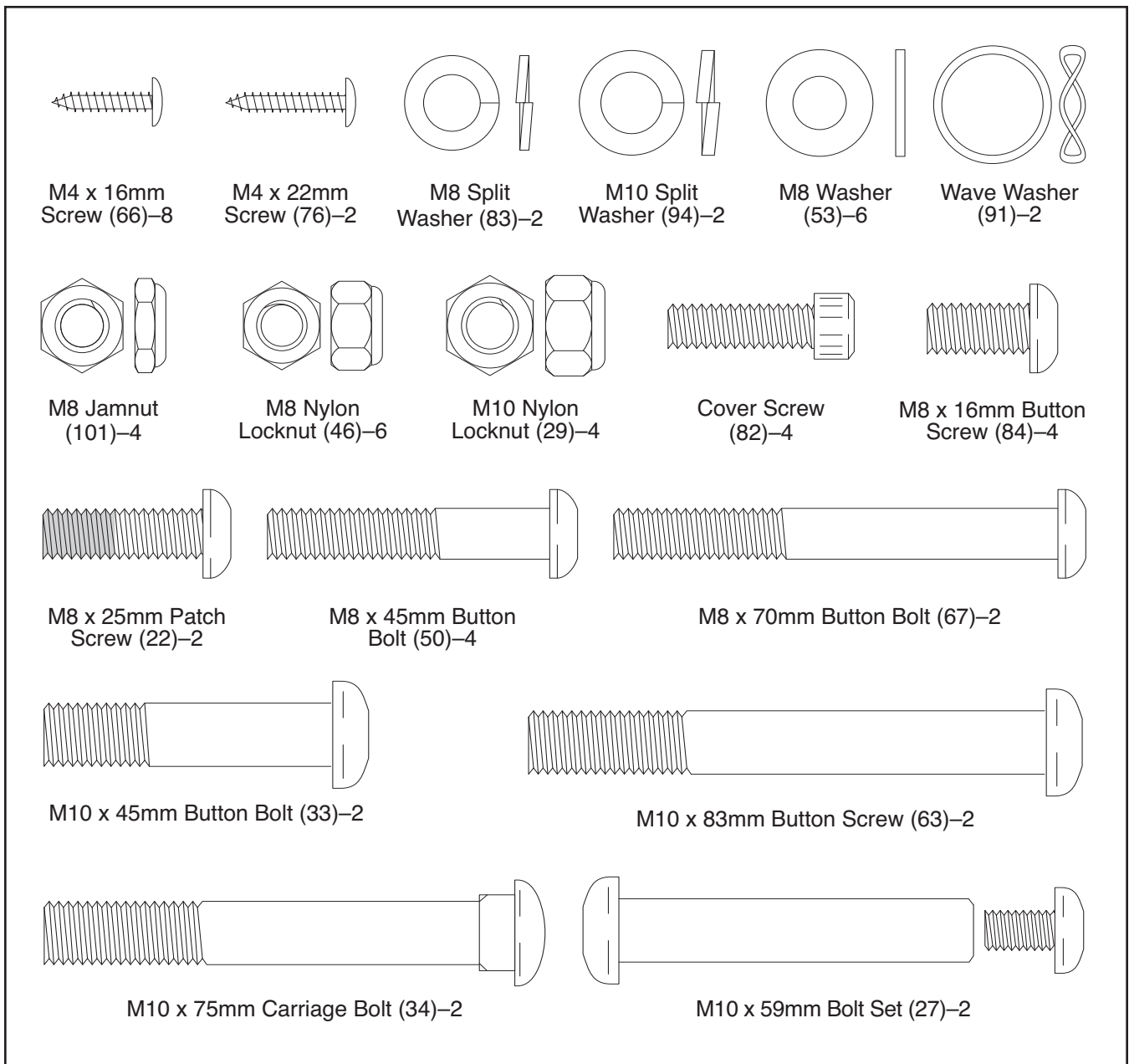

1.

To make assembly easier, read the information on page 5 before you begin assembling the elliptical exerciser.

Identify the Rear Stabilizer (4). While another person lifts the rear of the Frame (1), attach the Rear Stabilizer to the Frame with two M10 x 75mm Carriage Bolts (34) and two M10 Nylon Locknuts (29).

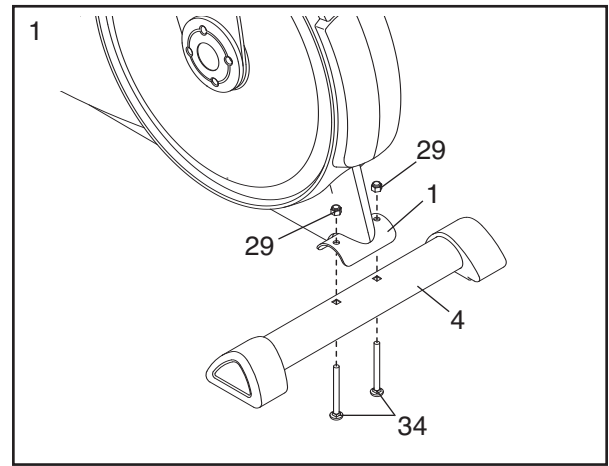

2. See the inset drawing. Remove the two M10 x 45mm Button Bolts (33) and the packing tubes from the front of the Frame (1). Remove the rubber band from the Lower Wire Harness (87). Discard the rubber band and the packing tubes.

Attach a Wheel (32) to the Front Stabilizer (3) with an M10 x 45mm Button Bolt (33) and an M10 Nylon Locknut (29). **Do not overtighten the Nylon Locknut; the Wheel should turn freely.**

Attach the other Wheel (32) to the Front Stabilizer (3) in the same way.

Press two Stabilizer Endcaps (35) onto the Front Stabilizer (3).

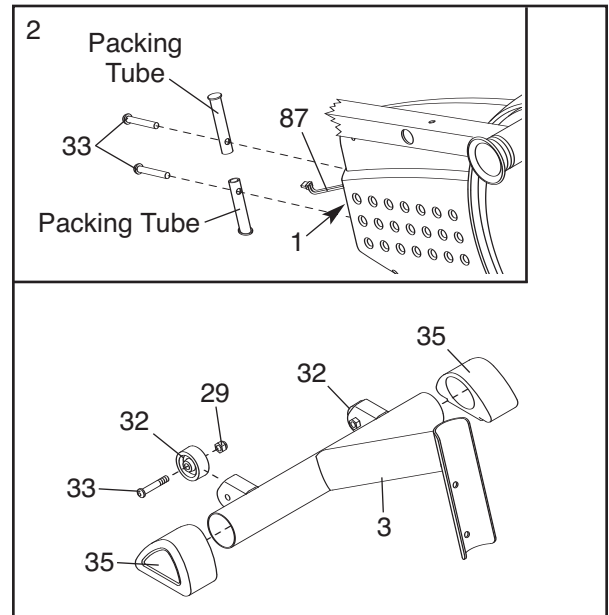

- Slide an M10 Split Washer (94) onto each of the two M10 x 83mm Button Screws (63). Insert the Button Screws into the Front Stabilizer (3). Next, slide the Mast (15) onto the Button Screws and against the Front Stabilizer. **Make sure that the Mast is oriented as shown.**

While another person holds the Mast (15) and the Front Stabilizer (3) near the Frame (1), connect the Extension Wire Harness (95) to the Lower Wire Harness (87). Insert the connectors on the Wire Harnesses into the Mast.

While the other person lifts the front of the Frame (1), **carefully pull the upper end of the Extension Wire Harness (95) to remove any slack. While holding the upper end of the Extension Wire Harness,** attach the Mast (15) and the Front Stabilizer (3) to the Frame with the two M10 x 83mm Button Screws (63). **Do not tighten the Button Screws yet.**

Be careful to avoid pinching the Wire Harnesses (87, 95) during this step.

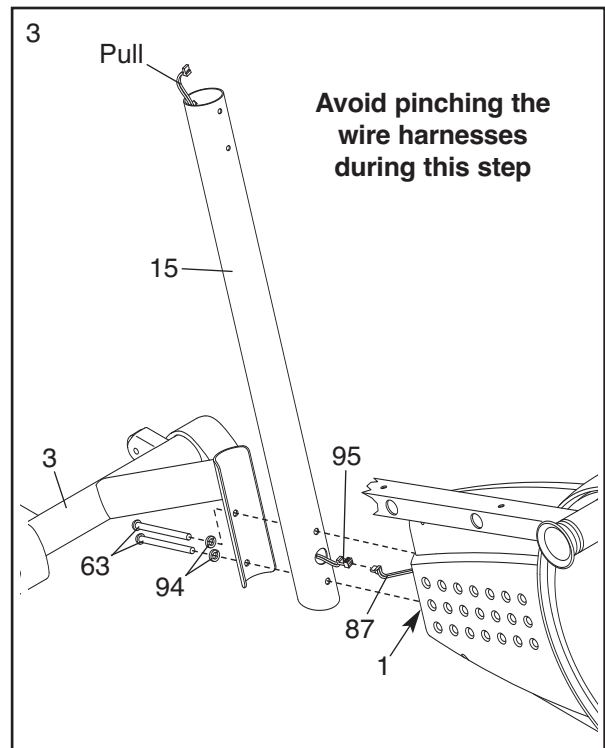

- While another person holds the Upright (2) in the position shown, connect the Upper Wire Harness (86) to the Extension Wire Harness (95).

Next, insert the Upright (2) into the Mast (15); **make sure that the Upright is oriented as shown.** Attach the Upright with two M8 x 70mm Button Bolts (67), two M8 Split Washers (83), and two M8 Nylon Locknuts (46). **Be careful to avoid pinching the Wire Harnesses (86, 95) during this step. Do not tighten the Button Bolts yet.**

Attach the Water Bottle Holder (72) to the Upright (2) with two M4 x 22mm Screws (76).

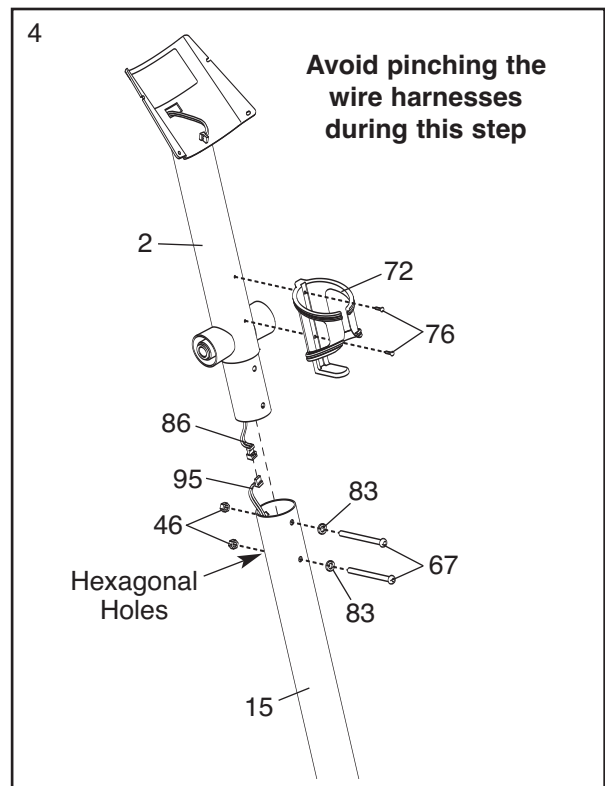

5. The Console (5) requires four “D” batteries (not included); alkaline batteries are recommended. **IMPORTANT: If the elliptical exerciser has been exposed to cold temperatures, allow it to warm to room temperature before inserting batteries into the Console. If you do not do this, the console displays or other electronic components may become damaged.** Press the tab on the battery cover and remove the battery cover. Insert four batteries into the Console as shown. **Make sure that the batteries are oriented as shown by the markings on the battery cover.** Reattach the battery door.

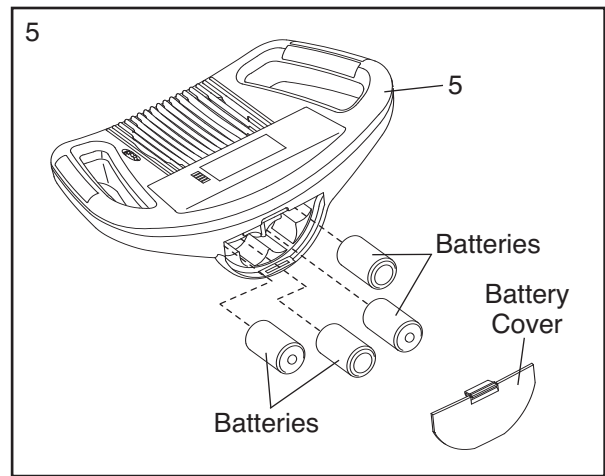

6. While another person holds the Console (5) near the Upright (2), connect the wire harness on the Console to the Upper Wire Harness (86). Insert the excess wire harness down into the Upright. Next, attach the Console to the Upright with four M4 x 16mm Screws (66). **Be careful to avoid pinching the wire harnesses.**

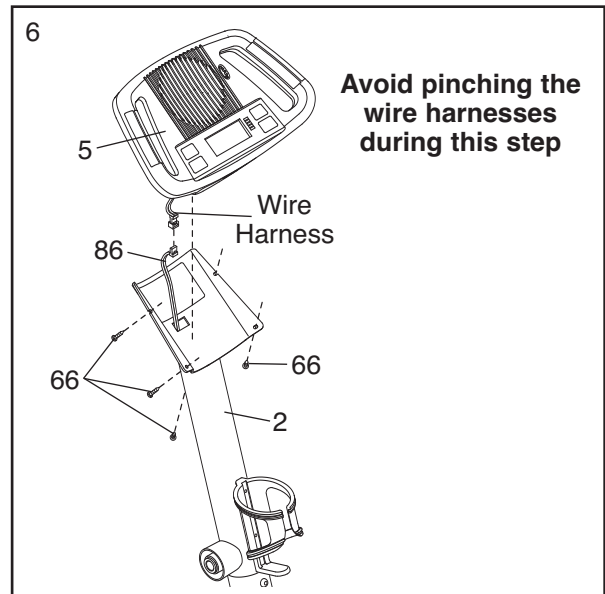

7. Slide the Right Crank Arm (38) onto the four indicated welded bolts; **make sure that the Right Crank Arm is in the indicated cutout in the Left Pedal Disc (8).** Next, finger tighten four M8 Jamnuts (101) onto the welded bolts. Then, fully tighten one of the Jamnuts, and then tighten the Jamnut farthest from the first Jamnut. Then, tighten the remaining two Jamnuts.

Attach a Hub Cover (48) to the Right Crank Arm (38) with four Cover Screws (82). Then, tighten an Adjustment Knob (45) onto the right Adjustment Pin (17).

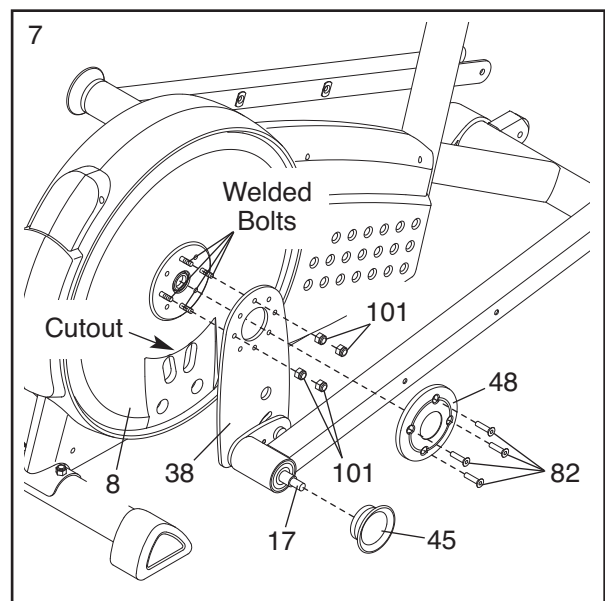

8. Attach two Pedal Posts (16) to the Left Pedal Arm (14) with two M8 x 16mm Button Screws (84) and two M8 Washers (53).

Attach the other Pedal Posts (not shown) to the Right Pedal Arm (75) in the same way.

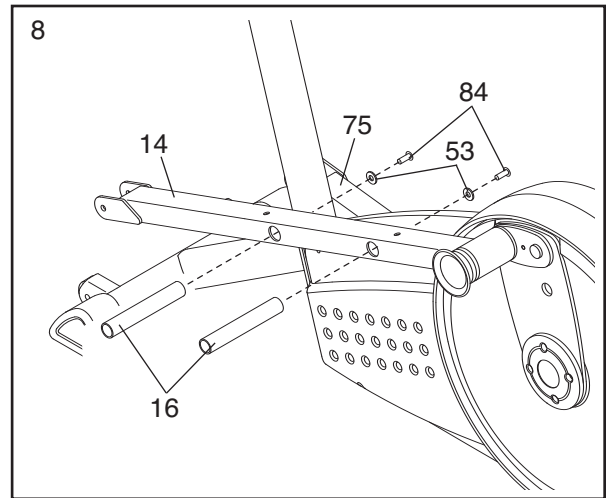

9. Attach one of the Pedals (12) to the Left Pedal Arm (14) with two M4 x 16mm Screws (66).

Attach the other Pedal (not shown) to the Right Pedal Arm (not shown) in the same way.

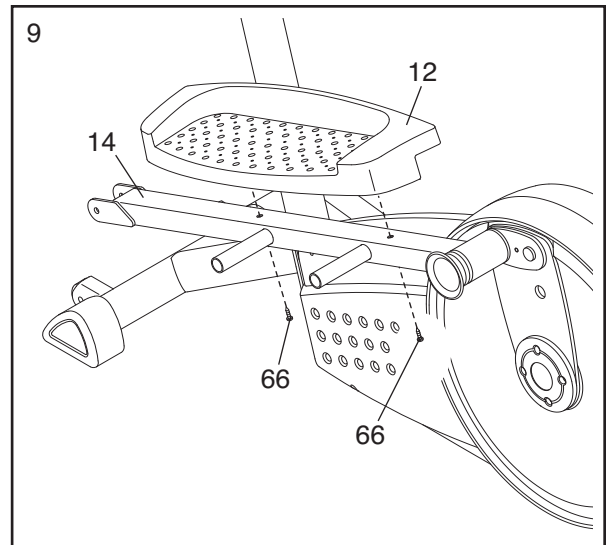

10. Identify the Left Handlebar (9), which is marked with a sticker. Insert the Left Handlebar into one of the Handlebar Legs (79); **make sure that the Handlebar Leg is turned so the hexagonal holes are on the indicated side.** Attach the Left Handlebar with two M8 x 45mm Button Bolts (50) and two M8 Nylon Locknuts (46). **Make sure that the Nylon Locknuts are inside of the hexagonal holes. Do not tighten the Button Bolts yet.**

Assemble the Right Handlebar (not shown) and the other Handlebar Leg (not shown) in the same way.

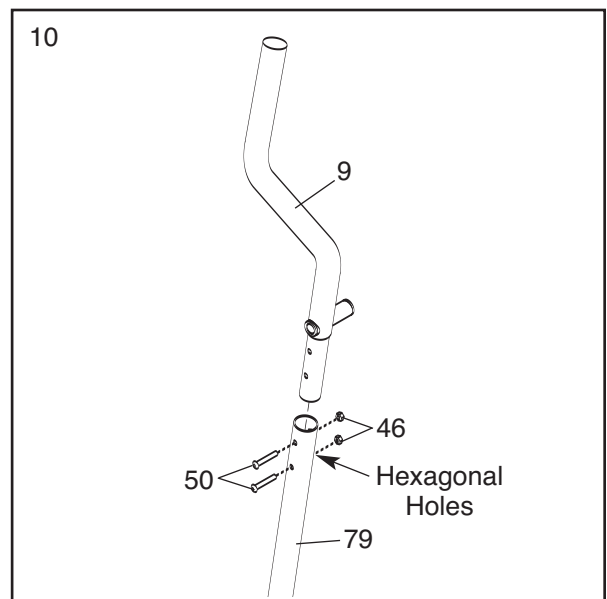

11. Apply a generous amount of the included grease to the Pivot Axle (81) and to two M8 Washers (53). Next, insert the Pivot Axle into the Upright (2) and center it. Reapply grease to both ends of the Pivot Axle.

Slide a Handlebar Spacer (25) onto the short tube on the Left Handlebar (9), and rotate the Handlebar Spacer so the small arrow is pointing toward the floor. Next, slide the Left Handlebar onto the left end of the Pivot Axle (81). Finger tighten an M8 x 25mm Patch Screw (22) with an M8 Washer (53) and a Wave Washer (91) into the end of the Pivot Axle. Then, press the small tabs on a Handlebar Cap (23) into the Handlebar Spacer.

Assemble the Right Handlebar (10) in the same way. Make sure that both Wave Washers (91) are on the Pivot Axle (81), and then tighten both M8 x 25mm Patch Screws (22) at the same time.

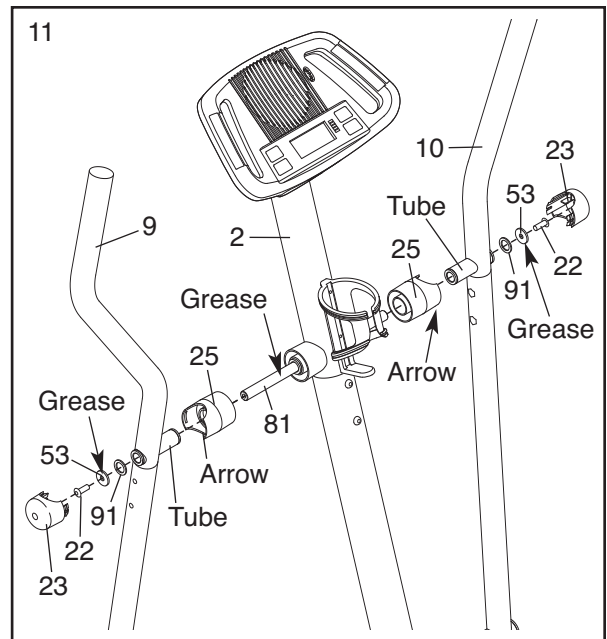

12. Apply a small amount of grease to an M10 x 59mm Bolt Set (27) and to the surfaces of the Leg Bushings (28) in the left Handlebar Leg (79). Attach the left Handlebar Leg to the Left Pedal Arm (14) with the Bolt Set. **Do not overtighten the Bolt Set; the left Handlebar Leg must pivot freely.**

Attach the right Handlebar Leg (79) to the Right Pedal Arm (75) in the same way.

See step 3. Tighten the two M10 x 83mm Button Screws (63). See step 4. Tighten the two M8 x 70mm Button Bolts (67). See step 10. Tighten the M8 x 45mm Button Bolts (50) in the Handlebar Legs (79).

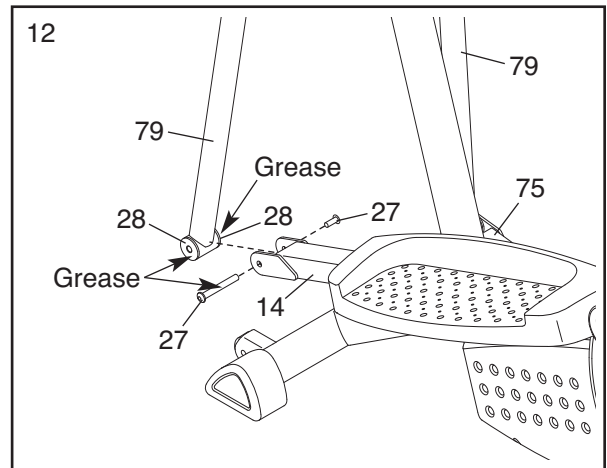

13. **Make sure that all parts of the elliptical exerciser are properly tightened.** Note: Some hardware may be left over after assembly is completed. To protect the floor or carpet from damage, place a mat under the elliptical exerciser.

HOW TO USE THE ELLIPTICAL EXERCISER

HOW TO EXERCISE ON THE ELLIPTICAL EXERCISER

To mount the elliptical exerciser, hold the handgrip pulse sensor and step onto the pedal that is in the lowest position. Next, step onto the other pedal. Push the pedals until they begin to move with a continuous motion. **Note: The pedal discs can turn in either direction. It is recommended that you move the pedal discs in the direction shown by the arrow below; however, for variety, you can turn the pedal discs in the opposite direction.**

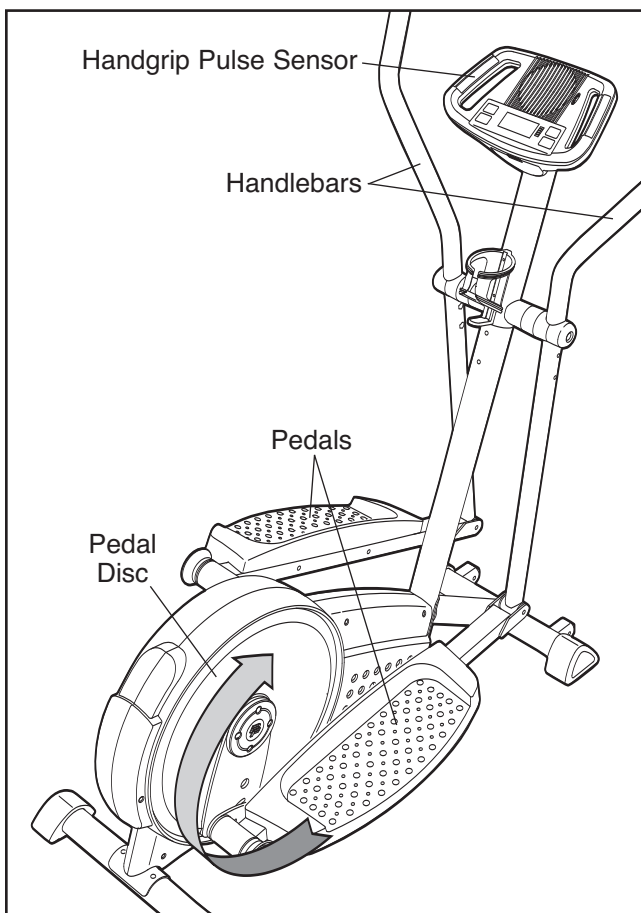

To dismount the elliptical exerciser, wait until the pedals come to a complete stop. **Note: The elliptical exerciser does not have a free wheel; the pedals will continue to move until the flywheel stops.** When the pedals are stationary, step off the highest pedal first. Then, step off the lower pedal.

HOW TO USE THE HANDLEBARS

The handlebars are designed to add upper-body exercise to your workouts. Push and pull the handlebars as you exercise to work your arms, shoulders, and back.

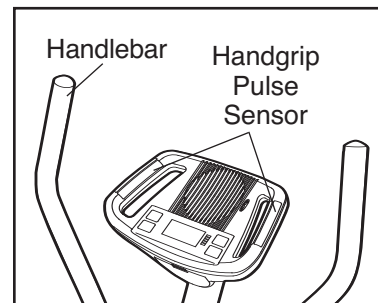

To exercise only your lower body, hold the handgrip pulse sensor as you exercise.

HOW TO ADJUST THE STRIDE OF THE ELLIPTICAL EXERCISER

To adjust the stride of the elliptical exerciser, first pull one of the adjustment knobs until the adjustment bracket can be pivoted freely. Then, pivot the adjustment bracket until the adjustment knob is aligned with either of the two holes in the crank arm, and gently release the knob. Pivot the adjustment bracket back and forth slightly to make sure that the adjustment pin is engaged in one of the holes. Adjust the other side of the elliptical exerciser in the same way.

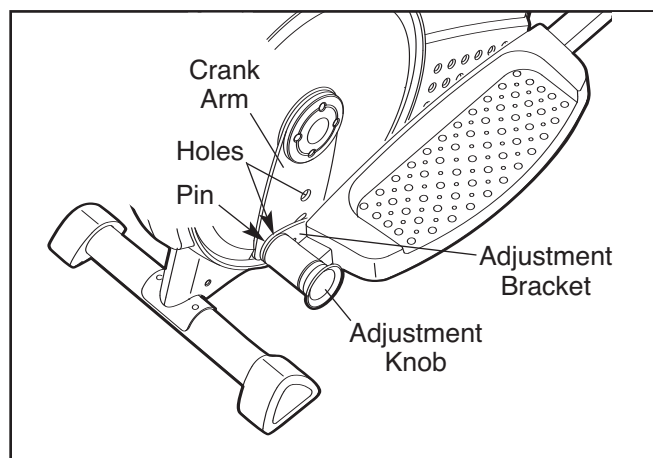
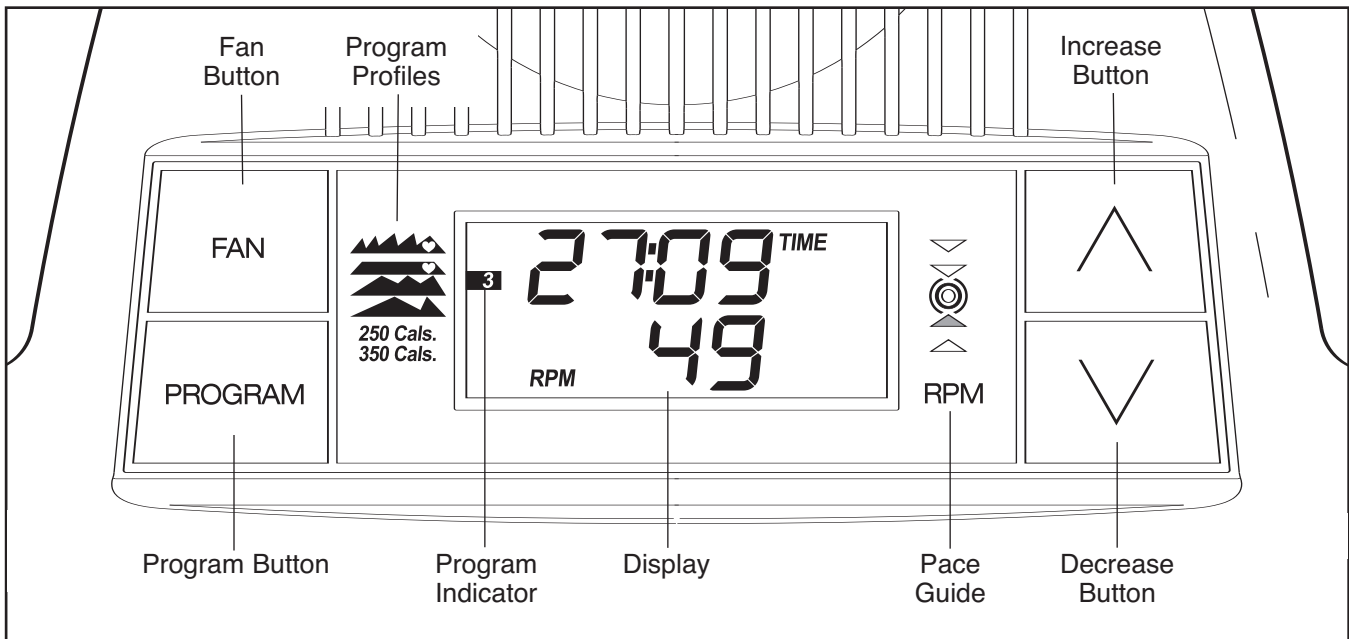

DIAGRAM OF THE CONSOLE



FEATURES OF THE CONSOLE

This advanced console offers a selection of features designed to make your workouts more effective. When you use the manual mode of the console, you can change the resistance of the pedals with the touch of a button. As you pedal, the console will provide continuous exercise feedback. You can even measure your heart rate using the built-in handgrip pulse sensor.

The console features two heart rate programs that allow you to enter target heart rate settings. The programs help you maintain the target heart rate by automatically changing the resistance of the pedals and prompting you to maintain your pedaling pace.

The console also offers two preset programs that automatically change the resistance of the pedals and

prompt you to vary your pedaling pace while guiding you through an effective workout.

Two calorie goal programs are designed to help you burn 250 or 350 calories. You can exercise at your desired pace and resistance level while the program counts down the calories you burn until you reach the goal.

To use the manual mode of the console, see page 13. **To use a heart rate program,** see page 14. **To use a preset program,** see page 15. **To use a calorie goal program,** see page 16.

Before using the console, make sure that batteries are installed (see assembly step 5 on page 8). If there is a sheet of clear plastic on the display, remove the plastic.

HOW TO USE THE MANUAL MODE

1 Turn on the console.

To turn on the console, press the Increase button or begin pedaling. The pace guide will light for a moment; the console will then be ready for use.

2 Select the manual mode.

When you turn on the console, the manual mode will be selected. If you have selected a program, reselect the manual mode by pressing the Program button repeatedly until no program indicators (see the drawing on page 12) appear along the left side of the display.

3 Change the resistance of the pedals as desired.

As you pedal, change the resistance of the pedals by pressing the Increase and Decrease buttons. There are ten resistance levels. Note: After you press the buttons, it will take a moment for the pedals to reach the selected resistance level.



4 Follow your progress with the display.

The upper half of the display will show the elapsed time, the distance (in total revolutions) you have pedaled, and the resistance level of the pedals. The display will change modes every few seconds. Note: When Program 1, 3, or 4 is selected, the display will show the time remaining in the program instead of the elapsed time.

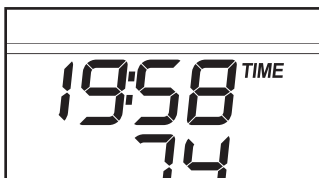

The lower half of the display will show your pedaling speed, in revolutions per minute (RPM), and the approximate number of calories you have burned. The display will change modes every few seconds. The lower half of the display will also show your heart rate when you use the handgrip pulse sensor (see step 5).

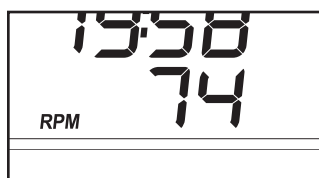

5 Measure your heart rate if desired.

If there are sheets of clear plastic on the metal contacts on the handgrip pulse sensor, remove the plastic.

Next, hold the handgrip pulse sensor with your palms resting on the contacts. When your pulse is detected, the heart-shaped indicator in the lower half of the display will flash each time your heart beats, and then your heart rate will appear in the display.

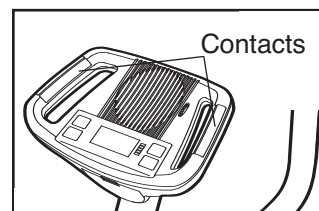

For the most accurate heart rate reading, continue to hold the handgrip pulse sensor for about 30 seconds. Note: If you continue to hold the handgrip pulse sensor, the display will show your heart rate for about 30 seconds. The display will then show your heart rate along with the other modes.

If your heart rate does not appear, make sure that your hands are positioned as described. Avoid moving your hands excessively or squeezing the metal contacts too tightly. For optimal performance, periodically clean the metal contacts using a soft cloth; **never use alcohol, abrasives, or chemicals to clean the contacts.**

6 Turn on the fan if desired.

To turn on the fan at low speed, press the Fan button. To turn on the fan at high speed, press the Fan button a second time. To turn off the fan, press the Fan button a third time. Note: If the fan is turned on but the pedals do not move for thirty seconds, the fan will automatically turn off to conserve the batteries.

Rotate the thumb tab on the right side of the fan to adjust the angle of the fan.

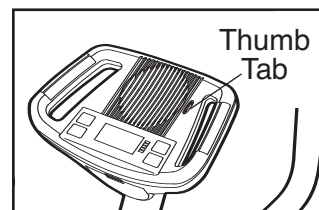

7 When you are finished exercising, the console will turn off automatically.

If the pedals do not move for a few seconds, the time will begin to flash in the display and the console will pause. If the pedals do not move for a few minutes, the console will turn off and the display will be reset.

HOW TO USE A HEART RATE PROGRAM

1 Turn on the console.

See step 1 on page 13.

2 Select a heart rate program.

To select a heart rate program, press the Program button repeatedly until the number 1 or 2 appears along the left side of the display. When you select a heart rate program, the target heart rate setting will flash in the display.

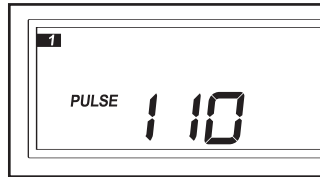

3 Enter a target heart rate.

If you select Program 1, the maximum target heart rate setting of the program will flash in the display. Use the Increase and Decrease buttons to change the maximum target heart rate setting, if desired. Note: If you change the maximum target heart rate setting, the intensity level of the entire program will change.

If you select Program 2, the target heart rate setting for the program will flash in the display. Use the Increase and Decrease buttons to change the target heart rate setting, if desired. Note: The same target heart rate setting will be programmed for the entire program.

4 Hold the handgrip pulse sensor.

It is not necessary to hold the handgrip pulse sensor continuously during a heart rate program; however, you should hold the handgrip pulse sensor frequently for the program to operate properly. **Each time you hold the handgrip pulse sensor, keep your hands on the metal contacts for at least 30 seconds.** When you are not holding the handgrip pulse sensor, the letters PLS will appear in the display instead of your heart rate.

5 Begin pedaling to start the program.

Program 1—This program is divided into 30 one-minute segments. One target heart rate setting is programmed for each segment. Note: The same target heart rate setting may be programmed for two or more consecutive segments.

Program 2—This program is divided into 30 one-minute segments. The same target heart rate is programmed for all segments of this program.

Both heart rate programs—As you pedal, the console will regularly compare your heart rate to the target heart rate setting. If your heart rate is too far below or above the target heart rate, the resistance of the pedals will automatically increase or decrease to bring your heart rate closer to the target heart rate.

During the program, the pace guide will also prompt you to maintain a steady pedaling pace. When one of the two lower indicators lights, increase your pace; when one of the two upper indicators lights, decrease your pace. When the center indicator lights, maintain your current pace. **Important: The pace guide is intended only to provide a goal. Make sure to pedal at a pace that is comfortable for you.**

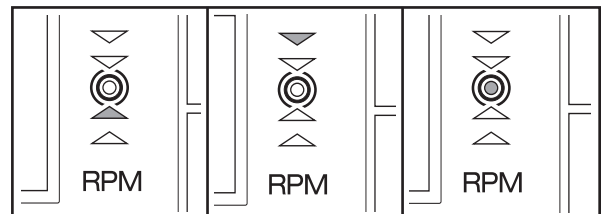

The display will show the time remaining in the program. If you stop pedaling for a few seconds, the program will pause and the time will flash in the display. To restart the program, simply resume pedaling.

6 Follow your progress with the display.

See step 4 on page 13.

7 Measure your heart rate if desired.

See step 5 on page 13.

8 Turn on the fan if desired.

See step 6 on page 13.

9 When you are finished exercising, the console will turn off automatically.

See step 7 on page 13.

HOW TO USE A PRESET PROGRAM

1 Turn on the console.

See step 1 on page 13.

2 Select a preset program.

To select a preset program, press the Program button repeatedly until the number 3 or 4 appears along the left side of the display. When you select a preset program, the display will show the length of the program.

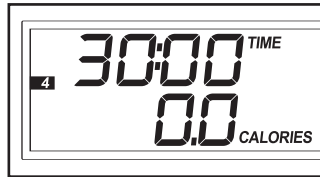

3 Begin pedaling to start the program.

Both preset programs consist of 30 one-minute segments. One resistance level and one target pace are programmed for each segment.

At the end of each segment, the resistance level will flash in the display for a few seconds. The resistance of the pedals will then automatically change to the resistance level programmed for the next segment. Note: If the resistance level is too low or too high, you can override it by pressing the Increase and Decrease buttons. However, when the current segment ends, the resistance will automatically change to the resistance level programmed for the next segment.

During the program, the pace guide will prompt you to increase or decrease your pedaling pace. When one of the two lower indicators lights, increase your pace; when one of the two upper indicators lights, decrease your pace. When the center indicator lights, maintain your current pace. **Important: The pace guide is intended only to provide a goal. Make sure to pedal at a pace that is comfortable for you.**

The display will show the time remaining in the program. If you stop pedaling for a few seconds, the program will pause and the time will flash in the display. To restart the program, simply resume pedaling.

4 Follow your progress with the display.

See step 4 on page 13.

5 Measure your heart rate if desired.

See step 5 on page 13.

6 Turn on the fan if desired.

See step 6 on page 13.

7 When you are finished exercising, the console will turn off automatically.

See step 7 on page 13.

HOW TO USE A CALORIE GOAL PROGRAM

1 Turn on the console.

See step 1 on page 13.

2 Select a calorie goal program.

Press the Programs button repeatedly until the number 5 or 6 appears along the left side of the display. When a calorie goal program is selected, the number of calories to be burned will appear in the display.



3 Begin pedaling to start the program.

Pedal at your desired pace and adjust the resistance level as desired. Both programs will count down the number of calories you have burned until you reach the calorie goal. Program 5 has a goal of 250 calories and Program 6 has a goal of 350 calories.

The display will show the elapsed time. If you stop pedaling for a few seconds, the program will pause and the time will flash in the display. To restart the program, simply resume pedaling.

4 Follow your progress with the display.

See step 4 on page 13.

5 Measure your heart rate if desired.

See step 5 on page 13.

6 Turn on the fan if desired.

See step 6 on page 13.

7 When you are finished exercising, the console will turn off automatically.

See step 7 on page 13.

MAINTENANCE AND TROUBLESHOOTING

Inspect and tighten all parts of the elliptical exerciser regularly. Replace any worn parts immediately.

To clean the elliptical exerciser, use a damp cloth and a small amount of mild soap. **Important: To avoid damage to the console, keep liquids away from the console and keep the console out of direct sunlight.**

BATTERY REPLACEMENT

If the console display becomes dim, the batteries should be replaced; most console problems are the result of low batteries. See assembly step 5 on page 8 for replacement instructions.

HANDGRIP PULSE SENSOR TROUBLESHOOTING

- Avoid moving your hands while using the handgrip pulse sensor. Excessive movement may interfere with heart rate readings.
- Do not hold the metal contacts too tightly; doing so may interfere with heart rate readings.
- For the most accurate heart rate reading, hold the metal contacts for about 30 seconds.
- For optimal performance of the handgrip pulse sensor, keep the metal contacts clean. The contacts can be cleaned with a soft cloth—**never use alcohol, abrasives, or chemicals.**

CONDITIONING GUIDELINES

WARNING:



Before beginning this or any exercise program, consult your physician. This is especially important for persons over the age of 35 or persons with pre-existing health problems.

The pulse sensor is not a medical device. Various factors may affect the accuracy of heart rate readings. The pulse sensor is intended only as an exercise aid in determining heart rate trends in general.

The following guidelines will help you to plan your exercise program. Remember that proper nutrition and adequate rest are essential for successful results.

EXERCISE INTENSITY

Whether your goal is to burn fat or to strengthen your cardiovascular system, the key to achieving the desired results is to exercise with the proper intensity. The proper intensity level can be found by using your heart rate as a guide. The chart below shows recommended heart rates for fat burning, maximum fat burning, and cardiovascular (aerobic) exercise.

165	155	145	140	130	125	115	
145	138	130	125	118	110	103	
125	120	115	110	105	95	90	
20	30	40	50	60	70	80	

To find the proper heart rate for you, first find your age at the bottom of the chart (ages are rounded off to the nearest ten years). Next, find the three numbers above your age. The three numbers are your “training zone.” The lower two numbers are recommended heart rates for fat burning; the highest number is the recommended heart rate for aerobic exercise.

Fat Burning

To burn fat effectively, you must exercise at a relatively low intensity level for a sustained period of time.

During the first few minutes of exercise, your body uses easily accessible *carbohydrate* calories for energy. Only after the first few minutes of exercise does your body begin to use stored *fat* calories for energy. If your goal is to burn fat, adjust the intensity of your exercise until your heart rate is near the lowest number in your training zone as you exercise.

For maximum fat burning, adjust the intensity of your exercise until your heart rate is near the middle number in your training zone as you exercise.

Aerobic Exercise

If your goal is to strengthen your cardiovascular system, your exercise must be “aerobic.” Aerobic exercise is activity that requires large amounts of oxygen for prolonged periods of time. This increases the demand on the heart to pump blood to the muscles, and on the lungs to oxygenate the blood. For aerobic exercise, adjust the intensity of your exercise until your heart rate is near the highest number in your training zone as you exercise.

WORKOUT GUIDELINES

Each workout should include the following three parts:

A warm-up, consisting of 5 to 10 minutes of stretching and light exercise. A proper warm-up increases your body temperature, heart rate, and circulation in preparation for exercise.

Training zone exercise, consisting of 20 to 30 minutes of exercising with your heart rate in your training zone. Note: During the first few weeks of your exercise program, do not keep your heart rate in your training zone for longer than 20 minutes.

A cool-down, with 5 to 10 minutes of stretching. This will increase the flexibility of your muscles and will help to prevent post-exercise problems.

EXERCISE FREQUENCY

To maintain or improve your condition, complete three workouts each week, with at least one day of rest between workouts. After a few months of regular exercise, you may complete up to five workouts each week if desired. The key to success is to make exercise a regular and enjoyable part of your everyday life.

SUGGESTED STRETCHES

The correct form for several basic stretches is shown at the right. Move slowly as you stretch—never bounce.

1. Toe Touch Stretch

Stand with your knees bent slightly and slowly bend forward from your hips. Allow your back and shoulders to relax as you reach down toward your toes as far as possible. Hold for 15 counts, then relax. Repeat 3 times. Stretches: Hamstrings, back of knees and back.

2. Hamstring Stretch

Sit with one leg extended. Bring the sole of the opposite foot toward you and rest it against the inner thigh of your extended leg. Reach toward your toes as far as possible. Hold for 15 counts, then relax. Repeat 3 times for each leg. Stretches: Hamstrings, lower back and groin.

3. Calf/Achilles Stretch

With one leg in front of the other, reach forward and place your hands against a wall. Keep your back leg straight and your back foot flat on the floor. Bend your front leg, lean forward and move your hips toward the wall. Hold for 15 counts, then relax. Repeat 3 times for each leg. To cause further stretching of the achilles tendons, bend your back leg as well. Stretches: Calves, achilles tendons and ankles.

4. Quadriceps Stretch

With one hand against a wall for balance, reach back and grasp one foot with your other hand. Bring your heel as close to your buttocks as possible. Hold for 15 counts, then relax. Repeat 3 times for each leg. Stretches: Quadriceps and hip muscles.

5. Inner Thigh Stretch

Sit with the soles of your feet together and your knees outward. Pull your feet toward your groin area as far as possible. Hold for 15 counts, then relax. Repeat 3 times. Stretches: Quadriceps and hip muscles.

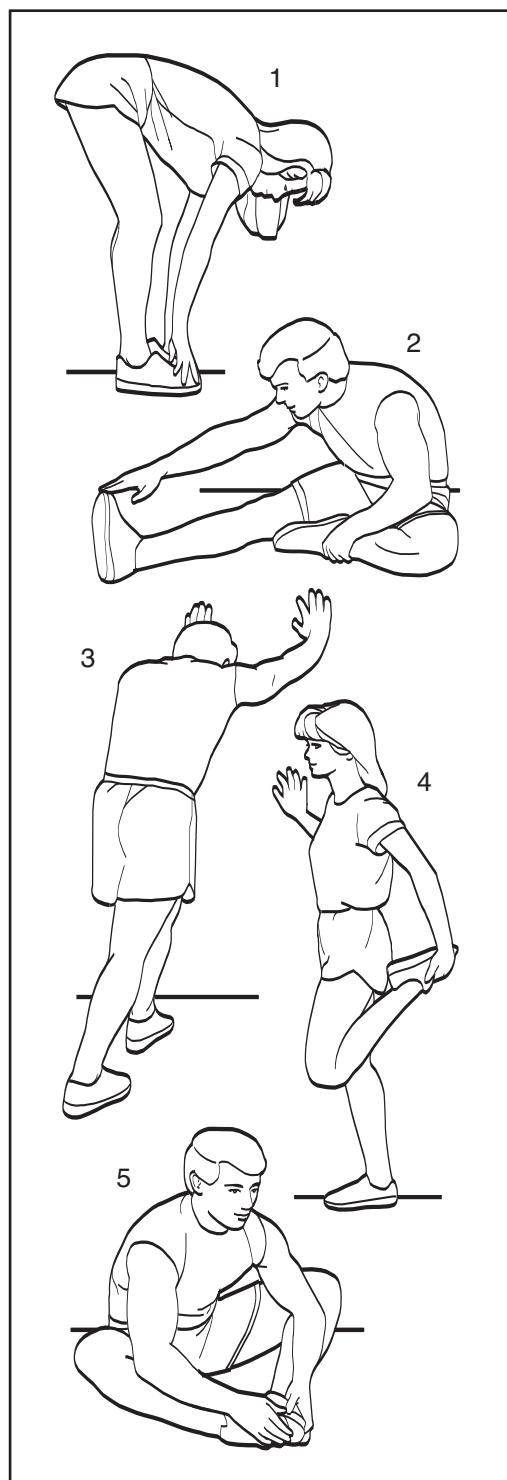

NOTES

PART LIST—Model No. PFEL3926.0

R0307A

Key No.	Qty.	Description	Key No.	Qty.	Description
1	1	Frame	54	1	“C” Magnet
2	1	Upright	55	1	Motor
3	1	Front Stabilizer	56	1	Belt
4	1	Rear Stabilizer	57	2	Hub
5	1	Console	58	1	Small Snap Ring
6	1	Left Side Shield	59	1	M5 x 40mm Screw
7	1	Right Side Shield	60	2	M6 Nut
8	1	Left Pedal Disc	61	4	M5 Nylon Locknut
9	1	Left Handlebar	62	4	M5 x 12mm Bolt
10	1	Right Handlebar	63	2	M10 x 83mm Button Screw
11	2	Foam Grip	64	1	M8 x 41mm Bolt
12	2	Pedal	65	2	Adjustment Bracket Screw
13	1	Upright Endcap	66	16	M4 x 16mm Screw
14	1	Left Pedal Arm	67	2	M8 x 70mm Button Bolt
15	1	Mast	68	3	Flywheel Screw
16	4	Pedal Post	69	1	Reed Switch Clamp
17	2	Adjustment Pin	70	1	Idler Screw
18	4	Pedal Arm Bushing	71	2	Handlebar Endcap
19	2	Adjustment Spring	72	1	Water Bottle Holder
20	2	Adjustment Bracket	73	1	M6 x 16mm Screw
21	2	Snap Ring	74	4	M4 x 38mm Screw
22	2	M8 x 25mm Patch Screw	75	1	Right Pedal Arm
23	2	Handlebar Cap	76	2	M4 x 22mm Screw
24	6	Handlebar Bushing	77	1	Reed Switch
25	2	Handlebar Spacer	78	1	Reed Switch Bracket
26	2	Upright Spacer	79	2	Handlebar Leg
27	2	M10 x 59mm Bolt Set	80	1	Return Spring
28	4	Leg Bushing	81	1	Pivot Axle
29	4	M10 Nylon Locknut	82	8	Cover Screw
30	1	Pillow Block	83	2	M8 Split Washer
31	1	Idler	84	4	M8 x 16mm Button Screw
32	2	Wheel	85	1	Resistance Cable
33	2	M10 x 45mm Button Bolt	86	1	Upper Wire Harness
34	2	M10 x 75mm Carriage Bolt	87	1	Lower Wire Harness
35	4	Stabilizer Endcap	88	2	Pedal Arm Sleeve
36	1	Left Crank Arm	89	2	M3 x 12mm Screw
37	1	Idler Bracket	90	4	Motor Washer
38	1	Right Crank Arm	91	2	Wave Washer
39	1	Crank	92	2	Inner Pedal Arm Sleeve
40	2	Crank Bearing	93	2	M6 Washer
41	1	Flywheel	94	2	M10 Split Washer
42	4	Large Snap Ring	95	1	Extension Wire Harness
43	1	Magnet	96	2	Pedal Arm Endcap
44	1	Flywheel Spacer	97	2	Pillow Block Retainer
45	2	Adjustment Knob	98	1	Idler Spacer
46	7	M8 Nylon Locknut	99	1	Idler Pulley
47	2	M10 Crank Nut	100	1	Idler Axle
48	2	Hub Cover	101	8	M8 Jamnut
49	1	M6 x 8mm Screw	102	1	Right Pedal Disc
50	4	M8 x 45mm Button Bolt	103	1	Flat Flywheel Screw
51	1	Tension Spring	#	2	Hex Key
52	1	Magnet Guide	#	1	Grease Packet
53	6	M8 Washer	#	1	User's Manual

Note: “#” indicates a non-illustrated part. Specifications are subject to change without notice. See the back cover of this manual for information about ordering replacement parts.

EXPLODED DRAWING A—Model No. PFEL3926.0

R0307A

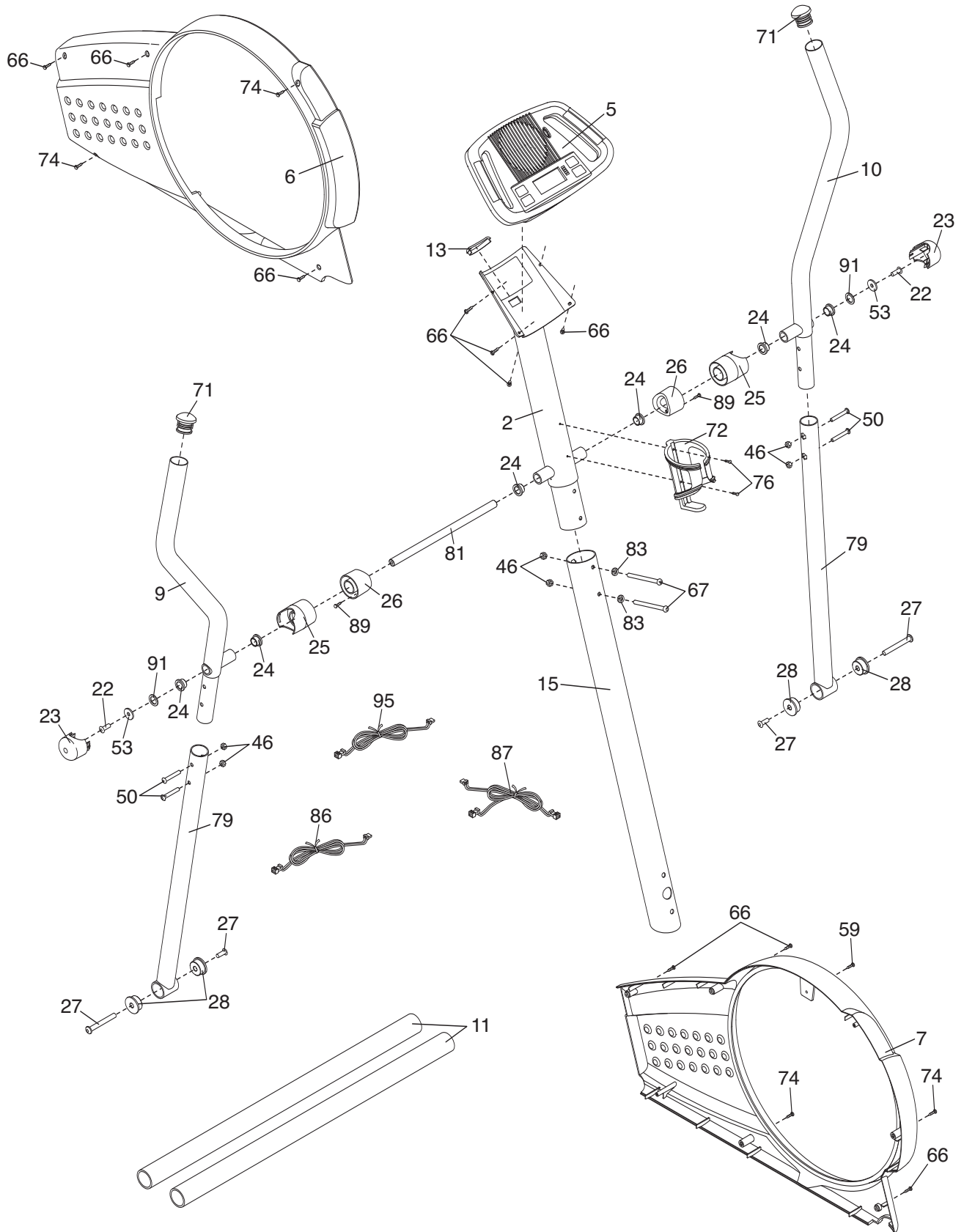

EXPLODED DRAWING B—Model No. PFEL3926.0

R0307A

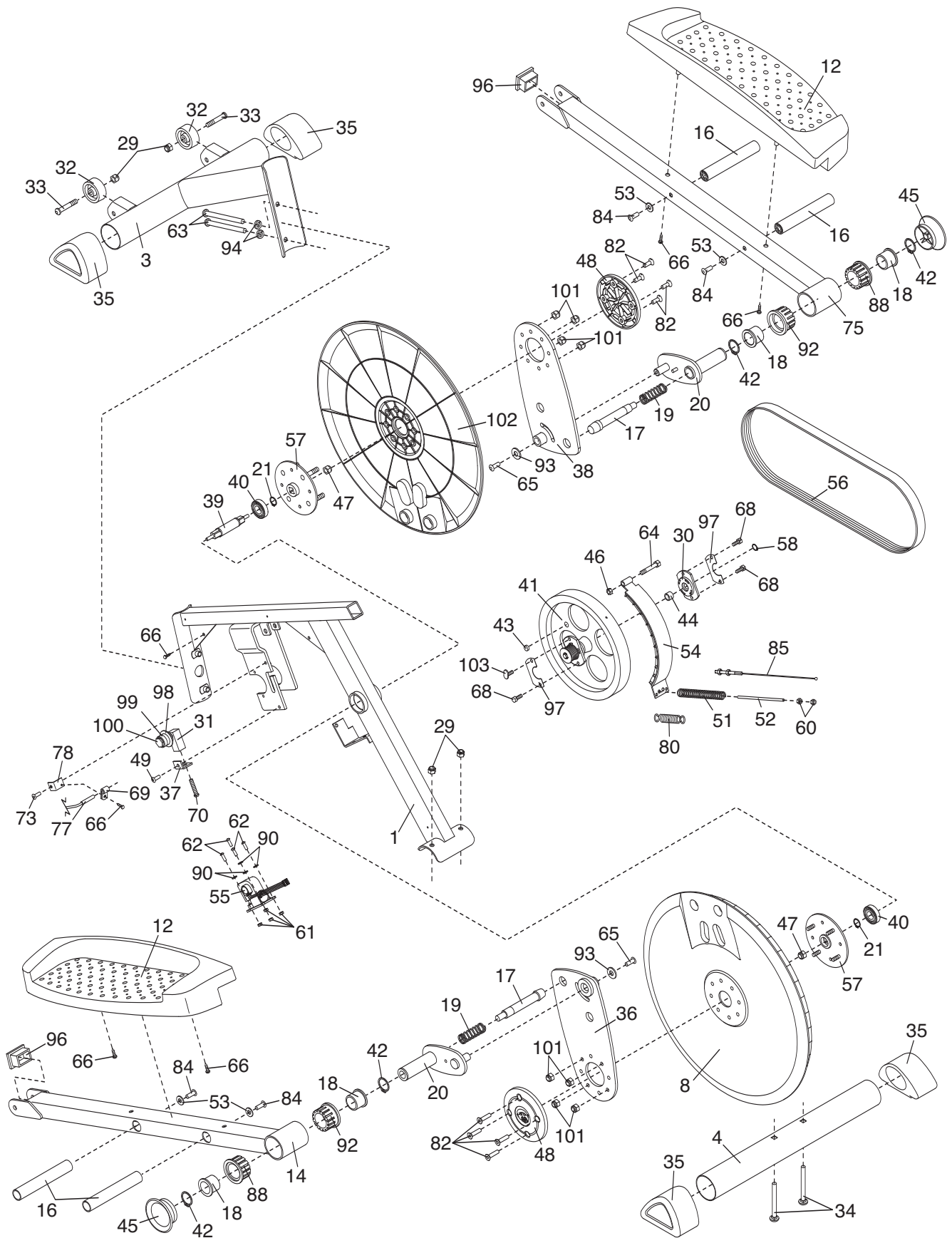

ORDERING REPLACEMENT PARTS

To order replacement parts, please see the front cover of this manual. To help us assist you, be prepared to give the following information when contacting us:

- the MODEL NUMBER of the product (PFEL3926.0)
- the NAME of the product (PROFORM STRIDE SELECT 830 elliptical exerciser)
- the SERIAL NUMBER of the product (see the front cover of this manual)
- the KEY NUMBER and DESCRIPTION of the part(s) (see pages 21 to 23)

LIMITED WARRANTY

ICON Health & Fitness, Inc. (ICON) warrants this product to be free from defects in workmanship and material, under normal use and service conditions, for a period of ninety (90) days from the date of purchase. This warranty extends only to the original purchaser. ICON's obligation under this warranty is limited to replacing or repairing, at ICON's option, the product through one of its authorized service centers. All repairs for which warranty claims are made must be pre-authorized by ICON. If the product is shipped to a service center, freight charges to and from the service center will be the customer's responsibility. For in-home service, the customer will be responsible for a minimal trip charge. This warranty does not extend to any product or damage to a product caused by or attributable to freight damage, abuse, misuse, improper or abnormal usage or repairs not provided by an ICON authorized service center; products used for commercial or rental purposes; or products used as store display models. No other warranty beyond that specifically set forth above is authorized by ICON.

ICON is not responsible or liable for indirect, special or consequential damages arising out of or in connection with the use or performance of the product or damages with respect to any economic loss, loss of property, loss of revenues or profits, loss of enjoyment or use, costs of removal or installation or other consequential damages of whatsoever nature. Some states do not allow the exclusion or limitation of incidental or consequential damages. Accordingly, the above limitation may not apply to you.

The warranty extended hereunder is in lieu of any and all other warranties and any implied warranties of merchantability or fitness for a particular purpose is limited in its scope and duration to the terms set forth herein. Some states do not allow limitations on how long an implied warranty lasts. Accordingly, the above limitation may not apply to you.

This warranty gives you specific legal rights. You may also have other rights which vary from state to state.

ICON HEALTH & FITNESS, INC., 1500 S. 1000 W., LOGAN, UT 84321-9813

Free Manuals Download Website

<http://myh66.com>

<http://usermanuals.us>

<http://www.somanuals.com>

<http://www.4manuals.cc>

<http://www.manual-lib.com>

<http://www.404manual.com>

<http://www.luxmanual.com>

<http://aubethermostatmanual.com>

Golf course search by state

<http://golfingnear.com>

Email search by domain

<http://emailbydomain.com>

Auto manuals search

<http://auto.somanuals.com>

TV manuals search

<http://tv.somanuals.com>