



INSTALLATION INSTRUCTIONS - INSTRUCCIONES PARA LA INSTALACIÓN CLAD WINDOWS WITH FLUSH FLANGE

Lea las instrucciones en español en el reverso

Installation Instructions for Replacement of Aluminum Windows in Hard Coat Stucco Applications in arid climates.

These instructions are designed for typical California hard coat stucco exterior applications. The installation must leave the existing aluminum window frame and weep system in place. **These instructions are not to be used with any other construction method and rely on the integrity of the existing aluminum window frame and flashing system.** Building designs, construction methods, building materials, and site conditions unique to your project may require an installation method different from these instructions and additional care. Determining the appropriate installation method is the responsibility of you, your architect, or construction professional. If you have questions, please contact your local Pella retailer.



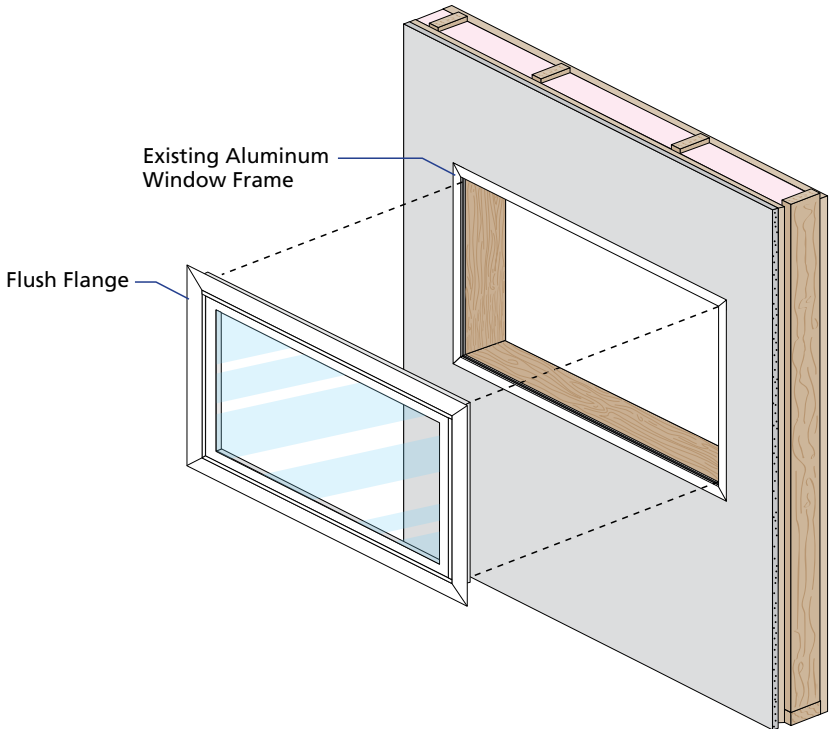

REMEMBER TO USE APPROPRIATE PERSONAL PROTECTIVE EQUIPMENT.



Always read the Pella® Limited Warranty before purchasing or installing Pella products. By installing this product, you are acknowledging that this Limited Warranty is part of the terms of the sale. Failure to comply with all Pella installation and maintenance instructions may void your Pella product warranty. See Limited Warranty for complete details at <http://warranty.pella.com>.

Download from www.Somanuals.com. All Manuals Search And Download.

YOU WILL NEED TO SUPPLY:

- Composite or Impervious shims/spacers (12 to 20) 
- Pressure-treated 2x4 (4-6 ft)
- 3-1/4" finish head screws (16-20)
- Wood blocking to support new window. (20-30 ft)
- Pella® SmartFlash™ foil backed butyl window and door flashing tape or equivalent 
- Pella Window and Door Installation Sealant or equivalent high quality, multi-purpose sealant (2 tubes per window) 
- Low expansion, low pressure polyurethane insulating window and door foam sealant - DO NOT use high pressure or latex foams 

TOOLS REQUIRED:

- Tape measure 
- Level 
- Sealant gun 
- Square 
- Screwdriver (Flat) 
- Utility knife 
- Hacksaw 
- 5/32" and 3/8" drill bit 
- 1/2" drill guide 
- Drill 
- Reciprocating saw 
- Electric shears, circular saw or table saw (optional) 

Installation will require two or more persons.

1 OPENING PREPARATION

- A. **Prior to removing the existing window sash and/or glass**, check that the frame size of the new window is 1/2" to 3/4" smaller than the inside of the existing frame or 1/2" to 3/4" smaller than the inside of the drywall return for the flush-cut method to make sure it will fit correctly.

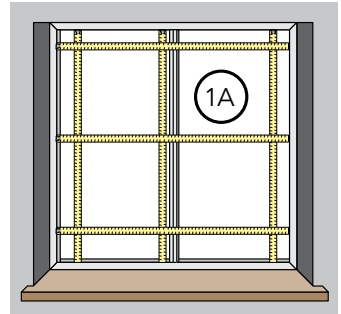

- B. **Prepare the window opening** by removing the sash and/or glass from the existing aluminum window frame.

Note: If a divider exists between vent and fixed glass areas it will be necessary to cut with a reciprocating saw or hacksaw and remove.

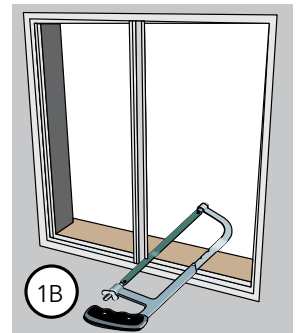

OPTIONAL FLUSH CUT METHOD

(Skip to step F for non flush cut installation)

- C. Using a reciprocating saw cut two passes 2" apart through the exiting window stop flanges. Do not cut into the drywall.

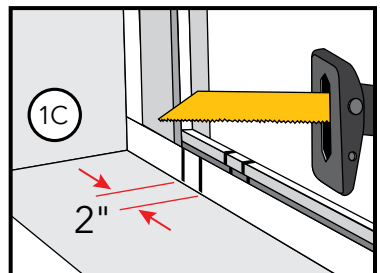

1 OPENING PREPARATION

- D. Use pliers to remove the 2" section(s) of frame.

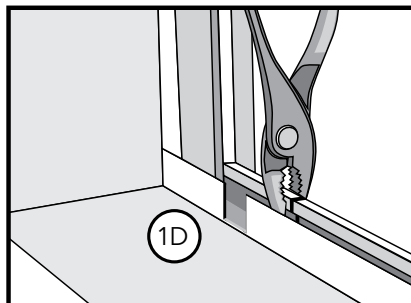

- E. Starting in the 2" frame notch, use a reciprocating saw to cut the frame legs flush with the drywall. Do not cut through the frame exposing the rough opening. Do not damage the drywall where it will remain exposed after the new window is in place.

Note: At the sill, ensure that 1/4" minimum height of frame leg remains to act as a sill dam.

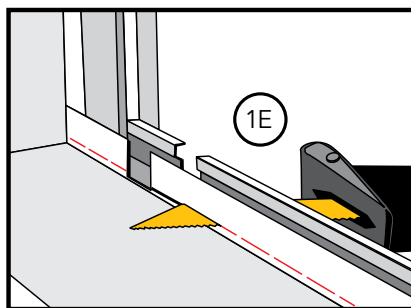

Repeat steps C - E for all four sides of the opening.

- F. **Remove any debris**, paint or stucco from the exterior face of the existing window frame that will interfere with the new window installation. Clean any dirt or debris from the existing sill and ensure the weep holes are open and clear.

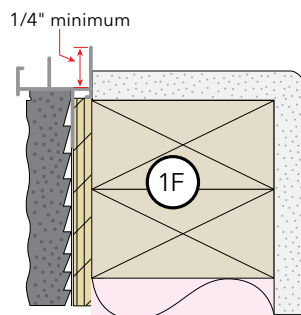

- G. **Seal the existing jamb frame joints** to the sill of the existing aluminum window frame with beads of sealant.
- H. **Seal any screw holes from the original divider** with sealant. DO NOT plug any weep holes in the existing frame.

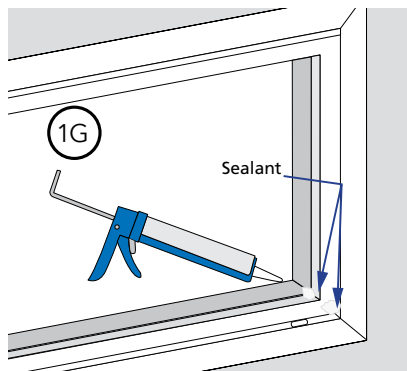

1 OPENING PREPARATION

I. Install wood blocking around the entire opening.

The blocking must be the same height as the existing aluminum window frame. The blocking must extend to the interior far enough to provide full support for the sill of the new window, however may extend as far to the interior as desired. Set blocking in sealant against drywall return to prevent air infiltration.

J. Apply sill flashing tape.

Cut a piece of flashing tape 6" longer than the existing aluminum frame width. Apply the tape bottom over the wood blocking so it overhangs 1" into the first sill cavity of the existing aluminum frame and goes up 3" each jamb.

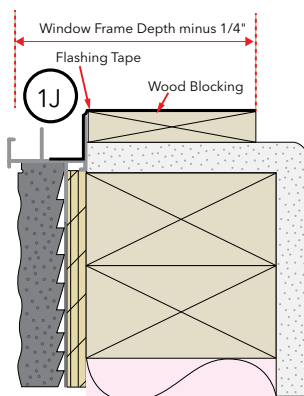

K. Cut treated wood or PVC filler to loosely fit the sill cavities in the existing aluminum frame.

This filler material will help support the weight of the new window, but should not prevent water drainage. The depth of the filler should be the same height as the tallest leg of the aluminum frame. Cut the sill filler to fill the entire length of the sill in both cavities. Cut notches in the sill filler to correspond with the weep holes of the existing aluminum window frame.

L. Install the wood filler into the existing aluminum frame.

Insert the sill filler with the notches over the existing window weep holes. DO NOT block any weep holes in the existing window.

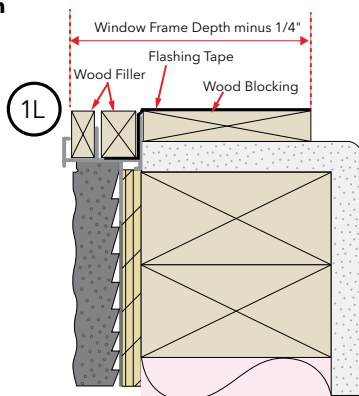
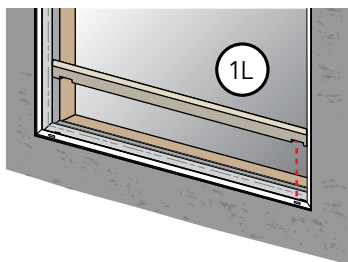

M. Install and level sill spacers.

Place 1" wide x 1/4-3/8" thick spacers on the bottom of the window opening 1/2" from each side and 1/2" back from the interior surface of where the new window will rest. Spacers are also required below mullions and at screw anchor locations.

Note: The depth of the shim should be equal to the window frame depth minus 1/2". Cut the shim to this dimension. Place the exterior edge of the shim flush with the exterior of the existing window. Improper placement of shims may result in bowing the bottom of the window.

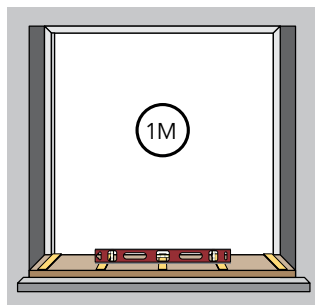

2 WINDOW PREPARATION

A. Casement:

On the room side of the window drill 1/8" diameter clearance holes through the head, jambs and sill of the frame. Space the holes a maximum of 6" from each end and a maximum of 16" on center.

Note: On vent casements, place the holes so they do not interfere with the roto operator and the latch points on the lock side of the window.

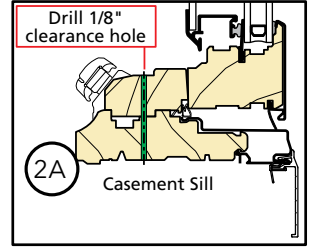
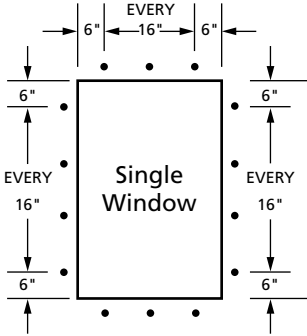

B. Double-hung and Clad Frame:

On the room side of the window, drill 1/8" diameter clearance holes through the frame at the locations shown. Space the holes a maximum of 6" from each end and a maximum of 16" on center.

Note: The lower sash must be raised to drill the holes in the sill of the double-hung window.

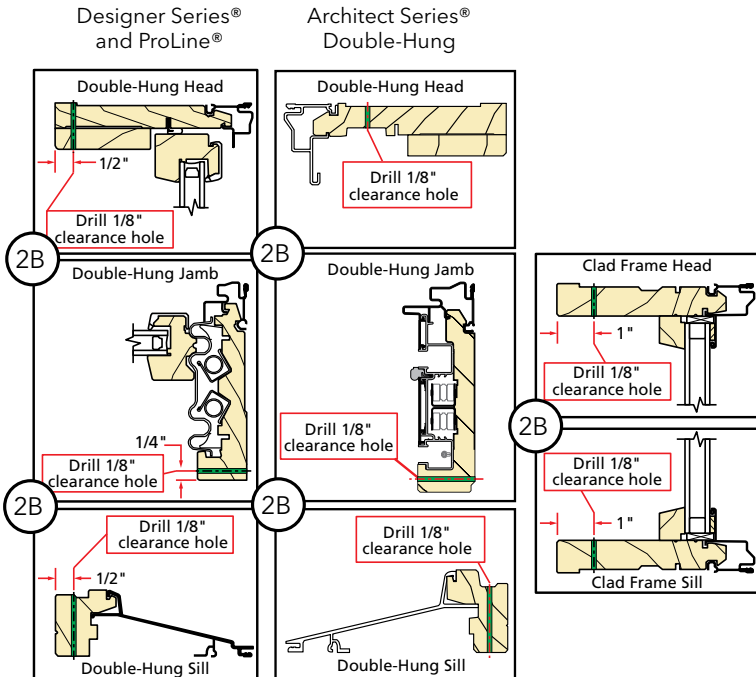

3 SETTING AND FASTENING THE WINDOW

- A. **Test fit the window** in the opening from the exterior. Insert shims around the window temporarily while you verify that the window will fit into the opening and the window flanges will overlap the stucco or existing aluminum window frame by a minimum of 3/4" on all (4) sides.

Note: Fix any problems with the opening before proceeding. If required, the exterior flush flange may be trimmed to fit inside exterior surround trim. Lay the window down on a flat surface. Use an electric shears, circular saw or table saw to cut the flange.

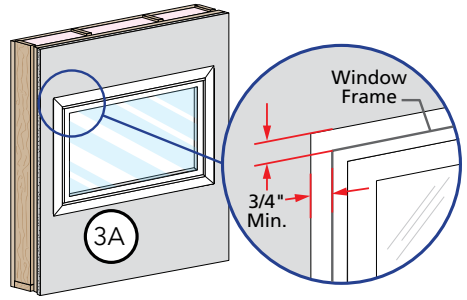

- B. **Apply Pella SmartFlash tape** across the head of the window extending 6" down each jamb. Place the tape starting on the aluminum cladding and extending onto the wood frame.

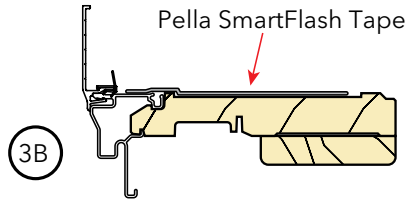
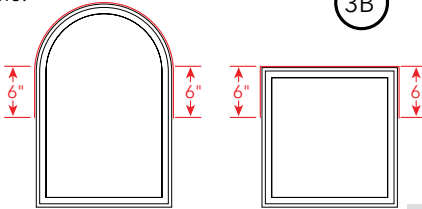

- C. **Place a 3/8" diameter (min.) line of sealant** around outside edge of the existing window frame where the frame meets the stucco. It is important to leave a 2" gap in the sealant line at each of the weep holes of the existing aluminum window frame.

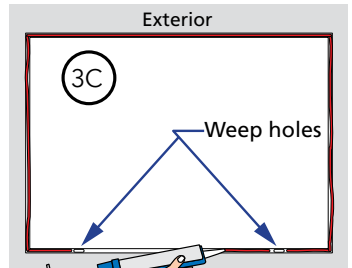

TWO OR MORE PERSONS WILL BE REQUIRED FOR THE FOLLOWING STEPS.

- D. **Insert the window from the exterior** of the building and center the window in the prepared opening.
- E. **Place a shim** aligned with the top pre-drilled hole in one jamb of the window frame. Trim all shims so they are recessed back 1/4" - 1/2" from the interior face of the window frame. Partially insert one 3-1/4" finish wood screw. Repeat on the other jamb.
- F. **Continue placing shims at each pre-drilled hole as needed** to plumb and square the window. Check the window for square by making sure the diagonal measurement from corner to corner of the replacement window is within 1/8" in both directions. Insert a 3-1/4" finish wood screw into each pre-drilled hole in the frame. Finish inserting the top screw in each jamb.

Note: DO NOT shim above the window. DO NOT over shim.

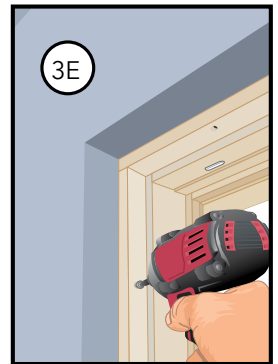

MAKE SURE THE FLANGE REMAINS PRESSED FIRMLY AGAINST THE WALL SURFACE WHILE PLACING SHIMS AND FRAME SCREWS

4 APPLY EXTERIOR PERIMETER SEALANT

- A. **Place a corner bead of sealant on the edge of the window flush flange** on top, sides and bottom to the stucco. Leave a 2" gap in the sealant bead at the bottom, corresponding to the weep hole locations in the existing aluminum window frame.

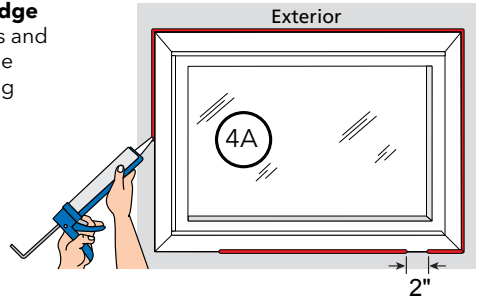

5 INTERIOR SEAL

CAUTION: Ensure use of low pressure polyurethane window and door insulating foams and strictly follow the foam manufacturer's recommendations for application. Use of high pressure foams or improper application of the foam may cause the window frame to bow and hinder operation.

- A. **Apply insulating foam sealant.** From the interior, insert the nozzle of the applicator approximately 1" deep into the space between the window frame (not jamb extension) and rough opening and apply a 1" deep bead of foam. This will allow room for expansion of the foam and will minimize squeeze-out. Apply sealant across the interior surface of shims to create a continuous seal. Follow manufacturer's instructions.

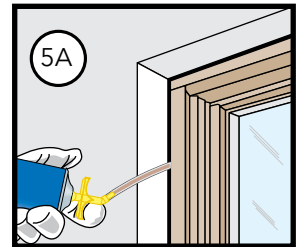

Note: It may be necessary to squeeze the end of the tube with pliers to be able to insert into the space between the window frame and the rough opening. DO NOT completely fill the space from the back of the flange to the interior face of the window

- B. **Check the window operation** (vent units only) by opening and closing the window.

Note: If the window does not operate correctly, check to make sure it is still plumb, level, square, and the jambs are not bowed. If adjustments are required, remove the foam with a serrated knife. Adjust the shims and reapply the insulating foam sealant.

Interior Finish or Trim:

The space between the new window and the existing window's frame will need to be covered with trim. There are many ways to accomplish this and each case can be unique. How this is done will be the decision of the homeowner or window installer. A few possibilities include using cove, quarter round, or a stop moulding.

EXTERIOR FINISH OF ALUMINUM CLAD WINDOWS

The exterior frame and sash are protected by aluminum cladding with our tough EnduraClad® or EnduraClad Plus baked-on factory finish that requires no painting. Clean this surface with mild soap and water. Stubborn stains and deposits may be removed with mineral spirits. DO NOT use abrasives. DO NOT scrape or use tools that might damage the surface.

Use of inappropriate solvents, brickwash or cleaning chemicals will cause adverse reactions with window and door materials and voids the Limited Warranty.

INTERIOR FINISH

If products cannot be finished immediately, cover with clear plastic to protect from dirt, damage and moisture. Remove any construction residue before finishing. Sand all wood surfaces lightly with 180 grit or finer sandpaper. DO NOT use steel wool. BE CAREFUL NOT TO SCRATCH THE GLASS. Remove sanding dust.

Pella products must be finished per the below instructions; failure to follow these instructions voids the Limited Warranty.

- On casement and awnings, it is optional to paint, stain or finish the vertical and horizontal sash edges.
- On single-hungs and double-hungs, do not paint, stain or finish the vertical sash edges; any finish on the vertical sash edges may cause the sash to stick. It is optional to paint, stain or finish the horizontal sash edges.
- On patio doors, it is optional to paint, stain or finish the vertical and horizontal panel edges.

Note: To maintain proper product performance do not paint, finish or remove the weather-stripping, mohair dust pads, gaskets or vinyl parts. Air and water leakage will result if these parts are removed. After finishing, allow venting windows and doors to dry completely before closing them.

Pella Corporation is not responsible for interior paint and stain finish imperfections for any product that is not factory-applied by Pella Corporation. Use of inappropriate finishes, solvents, brickwash, or cleaning chemicals will cause adverse reactions with the window and door materials and voids the Limited Warranty.

For additional information on finishing see Pella Owner's Manual or go to www.pella.com.

CARE AND MAINTENANCE

Care and maintenance information is available by contacting your local Pella retailer. This information is also available at www.pella.com.

IMPORTANT NOTICE

Because all construction must anticipate some water infiltration, it is important that the wall system be designed and constructed to properly manage moisture. Pella Corporation is not responsible for claims or damages caused by anticipated and unanticipated water infiltration; deficiencies in building design, construction and maintenance; failure to install Pella® products in accordance with Pella installation instructions; or the use of Pella products in wall systems which do not allow for proper management of moisture within the wall systems. The determination of the suitability of all building components, including the use of Pella products, as well as the design and installation of flashing and sealing systems are the responsibility of the Buyer or User, the architect, contractor, installer, or other construction professional and are not the responsibility of Pella.

Pella products should not be used in barrier wall systems which do not allow for proper management of moisture within the wall systems, such as barrier Exterior Insulation and Finish Systems, (EIFS) (also known as synthetic stucco) or other non-water managed systems. Except in the states of California, New Mexico, Arizona, Nevada, Utah, and Colorado, **Pella makes no warranty of any kind and assumes no responsibility for Pella windows and doors installed in barrier wall systems. In the states listed above, the installation of Pella products in barrier wall or similar systems must be in accordance with Pella installation instructions.**

Product modifications that are not approved by Pella Corporation will void the Limited Warranty.

Download from www.Somanuals.com. All Manuals Search And Download.

INSTALLING ROTO COVER AND CRANK

Note: Finish the interior of the window and allow the window to dry before proceeding with these instructions. (To open the window for finishing, partially insert the lock handle into the jamb, unlock the unit, temporarily attach the crank handle and turn to open.)

- A. **Place the cover over the operator stud** and snap into place. Position the pocket end of the cover into place.

Note: If the cover does not have the screw hole, apply pressure on the pocket end of the cover to snap the cover into place and proceed to step C.

- B. **Insert the provided screw into the hole in the bottom of the pocket.** Use a # 1 Phillips screwdriver to secure the pocket screw snug against the bottom of the pocket to avoid scratching the crank handle knob. **DO NOT** over tighten.

- C. **Use a medium size flat-blade screwdriver** to loosen the set screw in the crank handle.

- D. **Slide the crank handle onto the stud.** Unlock, open window, then close and lock window.

- E. **Fold the crank handle down** and check alignment of knob with the pocket.

Note: You may need to adjust the crank position on the stud until the correct alignment is achieved.

- F. **Open the crank** and tighten the set screw.

- G. **After the final installation,** fold the crank over and snap the knob into the pocket.

Note: Even with the window open the crank can be folded to avoid interfering with the window treatments.

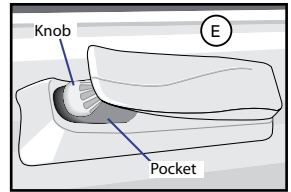
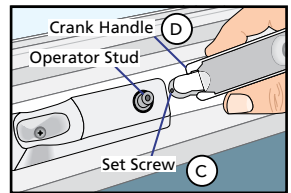
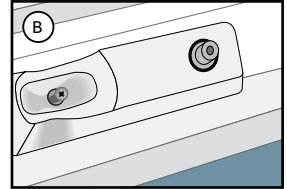
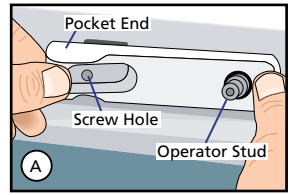

LOCK LEVER REMOVAL AND INSERTION

Note: You may want to remove the lock lever prior to finishing the window, or if it needs to be replaced with a lock lever in a different finish.

- A. **Unlock and open the window.**

- B. **Place the lock lever in the locked position.**

- C. **From the exterior of the window,** insert a small flat-blade screwdriver between the cam and lock lever near the bottom of the opening between the stop and frame gasket.

- D. **Push the screwdriver inwards** with a small amount of pressure; then turn the blade slightly clockwise for a left hand unit, counter-clockwise for a right hand units. **DO NOT** over-twist the screwdriver, this can damage the lock driver.

Note: This will release the hook in the lever from the cam hook.

- E. **Remove the lock lever** by pulling it toward the interior of the building.

- F. **To install a lock lever,** hold it in the lock position and insert it, from the interior, into the slot until it snaps into the cam.

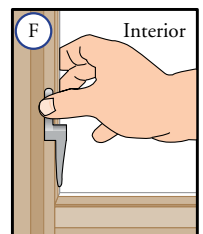
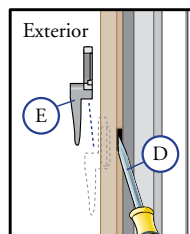
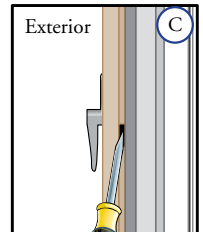
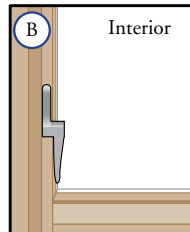

Free Manuals Download Website

<http://myh66.com>

<http://usermanuals.us>

<http://www.somanuals.com>

<http://www.4manuals.cc>

<http://www.manual-lib.com>

<http://www.404manual.com>

<http://www.luxmanual.com>

<http://aubethermostatmanual.com>

Golf course search by state

<http://golfingnear.com>

Email search by domain

<http://emailbydomain.com>

Auto manuals search

<http://auto.somanuals.com>

TV manuals search

<http://tv.somanuals.com>