

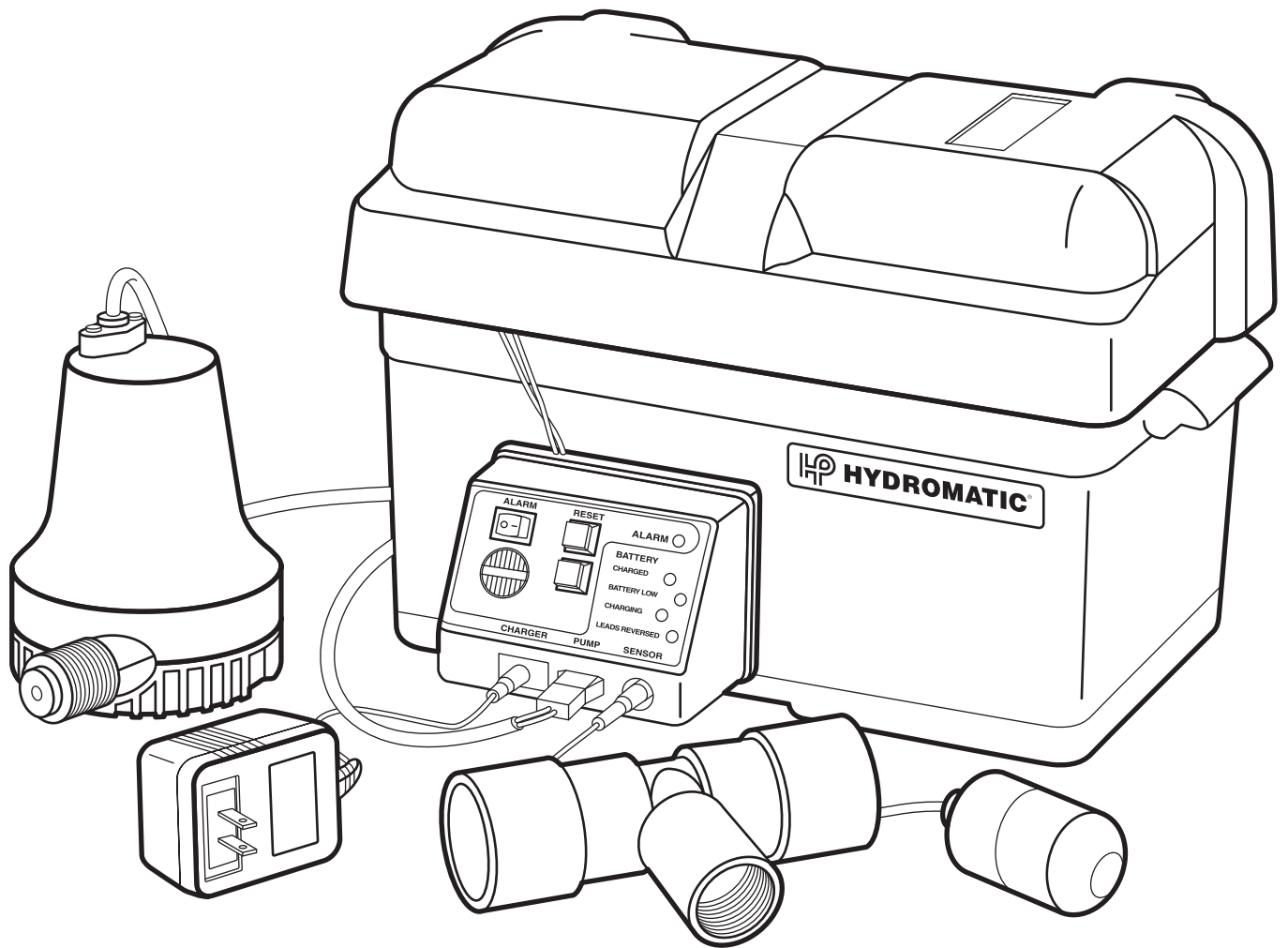

HYDROMATIC®

FG-A1

12 Volt Battery Back-Up Power Supply



NOTE! To the installer: Please make sure you provide this manual to the owner of the pumping equipment or to the responsible party who maintains the system.



**Pentair
Water™**

General Information

Before Operation:

Read the following instructions carefully. Reasonable care and safe methods should be practiced. Check local codes and requirements before installation.

Attention:

This manual contains important information for the safe use of this product. Read this manual completely before using this product and refer to it often for continued safe product use. **DO NOT THROW AWAY OR LOSE THIS MANUAL.** Keep it in a safe place so that you may refer to it often.

Warning:

Before handling these pumps and controls, always disconnect the power first. Do not smoke or use sparkable electrical devices or flames in a septic (gaseous) or possible septic sump.

FG-A1 and Pump Warning

CAUTION AND WARNING

Important Safety Instructions

Rules for Safe Installation and Operation

1. READ THESE RULES AND INSTRUCTIONS CAREFULLY. Failure to follow them could cause serious bodily injury and/or property damage.

2. Check local plumbing and electrical codes before installing. You must comply with those rules.
3. Battery box must be kept in a cool, dry, well ventilated area.
4. Battery must not be exposed to any sparks or flames. An explosion or fire could result.
5. Battery acid is very corrosive; avoid spilling on skin or clothing. Eye protection must be worn when handling the battery.
6. Battery Selection and Maintenance
Use a new 12 volt, fully charged battery with top terminals. For maximum performance and battery life, a deep cycle (marine, group 24, min. 105 AH) battery should be used.
 - The electrolyte level should be checked monthly and filled as required. Automotive batteries may be used but a slight decrease in performance and battery life will result.
 - Group 24 batteries will fit into the battery box with maximum battery dimensions of 12" long x 6-1/2" wide x 9" high to the top of the terminals.
 - Replace the battery if the back-up pump operated for an extended period of time and the battery is severely discharged. It is also recommended that the battery be replaced every three years even if the system is not used.
7. When service is required, proceed carefully:
Disconnect the power at the main electrical service box by turning the circuit breaker off or by removing the fuse.
Disconnect the battery charger from the wall after the power is disconnected.
DO NOT lift the pump by the cord.
8. To be used only as a back-up sump pump in residential waste water applications. **DO NOT** run the pump dry.

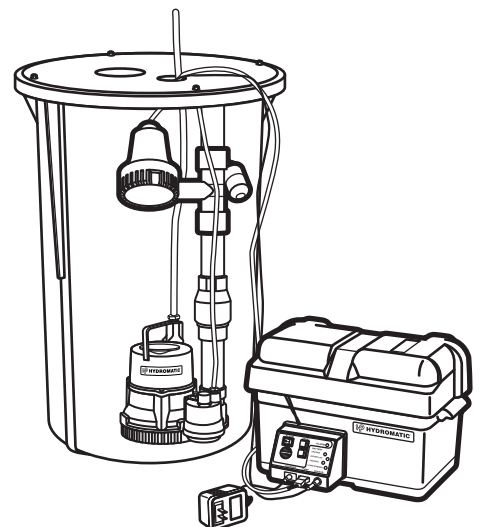

FG-A1 Installation

1. Disconnect power to the primary sump pump.
2. Assemble control panel to battery box with four screws included.
3. Position 12 volt battery (not provided) into battery box.
4. Assemble the two lead wires from control panel to the battery with the two battery clamps included per Fig. 2.

Note: Assemble RED wire to POSITIVE (+) battery terminal and BLACK wire to the NEGATIVE (-) battery terminal. The RED wire is supplied with an in-line fuse (10 amps, 250 volt rating) to protect the battery, pump and wiring should a short, over-current or ground fault occur.

If this fuse must be replaced for any reason, it must be replaced with one of the exact same rating. Failure to do so may result in a fire hazard. If the polarities are connected wrong, the REVERSE battery indicator light on the control panel will come on. Correct the battery wire connections (replace the 1 amp fuse on control panels equipped with fuse).

If voltage of the battery is lower than DC 11 volts, the LOW battery indicator light will

come on and the buzzer sounds for the ALARM function. Battery should be checked by a battery shop.

5. Assemble back-up pump a minimum of 1" above the primary pump and tilt 30° (per Figure 1 below).

The enclosed pump includes a built-in check valve and screws directly into the side of the tee included.

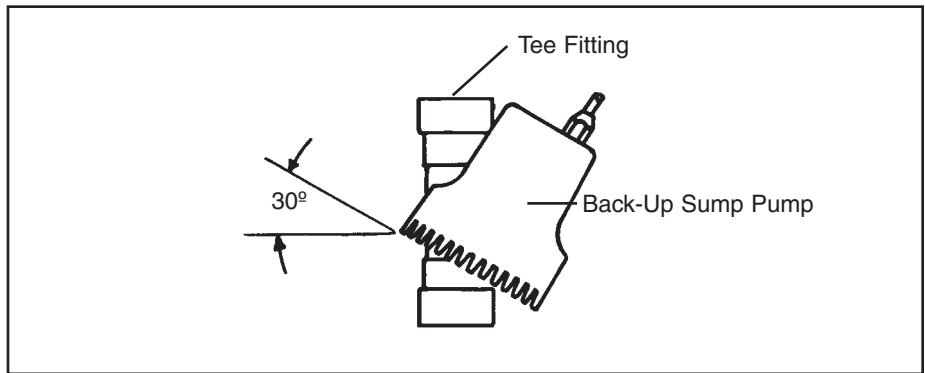

Figure 1 Tilting Pump

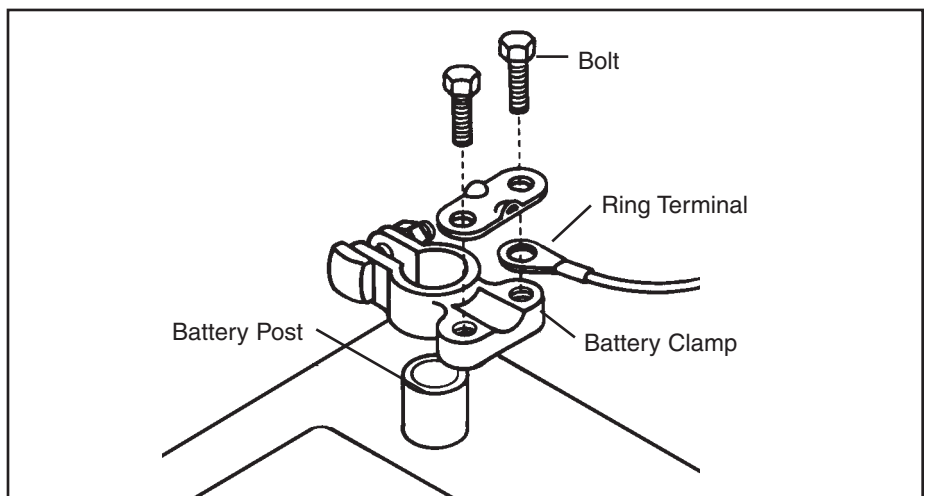

Figure 2 Attaching Ring Terminals and Battery Clamps

The other two ends of the tee will accept 1-1/4" or 1-1/2" PVC and ABS pipe. An additional check valve (not included) must be installed between the primary pump and this pump. (See page four.)

The nylon belt with buckle, two rigid nylon straps and four screws are not needed and can be discarded.

6. Attach the float switch to the discharge pipe with a wire tie. Be sure that the turn off or down position of the float is above the suction inlet of this pump. Tether at 1-1/4." Insert the plug of the float switch into the SENSOR socket of the control panel.
7. Insert the plug of the battery charger into the CHARGER socket of the control panel and plug the charger into an AC-115 volt power outlet (Figure 3 on page five).

FG-A1 Installation

8. Insert the plug of the pump into the PUMP socket of the control panel.
9. Push the RESET button and the unit is ready for operation.
10. The back-up sump pump should be checked by unplugging the primary sump pump and filling the sump basin with water. When the water level is slightly above the back-up sump pump it should turn on. As the water level drops, the back-up sump pump should turn off before the water level reaches the bottom of the back-up pump. If not, raise the float switch slightly. Press the RESET and plug the primary sump pump back in.

Note: Be sure that there is a 4" minimum from the top of the back-up pump to the top of the sump. The float switch should turn this pump ON near the top of the pump and at least 2" down from the top of the sump.

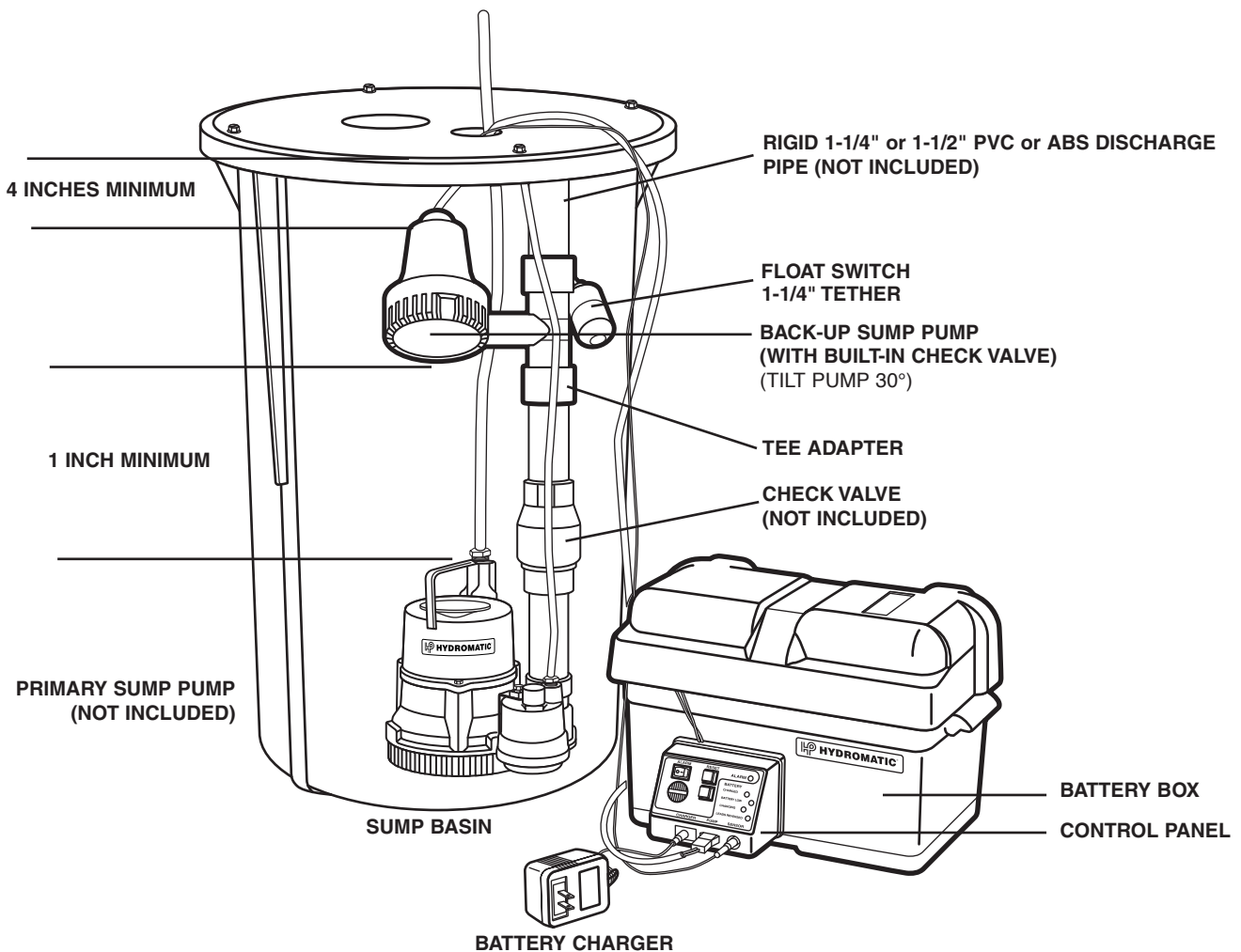

FG-A1 Testing and Operation

TESTING

After installation, unplug the primary sump pump and fill the sump with water. This is actually imitating the condition that would happen if the power went off or the primary pump failed for whatever reason. The back-up sump pump should begin operation as the water level rises just above it's top. If not, the float sensor may need to be re-positioned, review float installation instructions. Even after the back-up has pumped the excess water out and shut off, the alarm should continue sounding until the ALARM switch is set to the OFF position.

The alarm continues to sound until the ALARM switch is set to OFF to alert you that something is wrong with the primary sump pump.

If the back-up pump operates properly, plug in the primary sump pump and set the ALARM switch ON and press the RESET button. The back-up system is now in full readiness.

If the back-up pump does not operate as specified, refer to the most asked questions list.

OPERATION

When the FLOAT SWITCH turns the back-up pump ON, the alarm

buzzer will sound. When the FLOAT switch turns the backup OFF, the buzzer will continue to sound until the ALARM switch is pushed to the OFF position. Push the ALARM switch to the ON position. Press the RESET button for normal operation.

If the voltage of the battery drops lower than 11 volts DC, the LOW battery indicator will come on and the buzzer will sound if the ALARM switch is in the ON position. At this time, the battery should be checked and serviced or replaced. The only "real" test for a battery is when it is tested with a load meter. Take the battery back where it was purchased for the test. The CHARGING indicator will come ON when the battery is UNDERCHARGED.

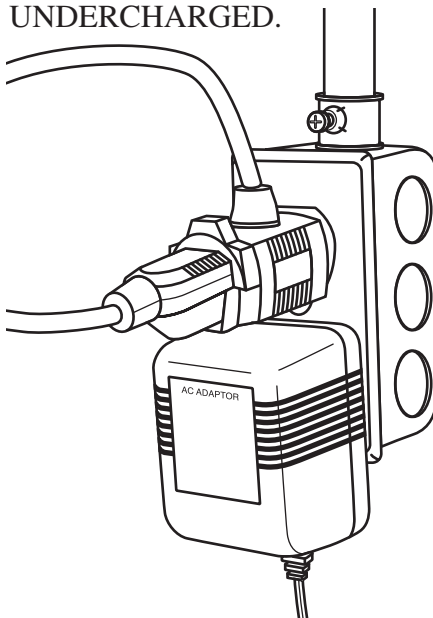

Figure 3 AC-115 V Outlet and Hydromatic piggyback switch plug

The CHARGING indicator will turn OFF when the DC voltage is over 13 volts, then the CHARGED indicator will come ON. At this time the battery is at FULL-CHARGED condition and will stop charging.

The CHARGED indicator will be ON until the DC voltage drops. The battery will start charging again and the CHARGING indicator will come ON. If either CHARGING indicator and CHARGED indicator are not ON, check the charger adaptor for proper connection.

Near the end of the CHARGING cycle, the CHARGING and CHARGED indicators may alternately blink. If the lights blink continuously, check the battery leads for proper polarity (Step 4) and replace the fuse.

Press PUMP TEST switch for pump function test: the pump comes ON and ALARM indicator comes ON and BUZZER sounds. Release the PUMP TEST switch, the pump turns OFF but the BUZZER continues to sound and ALARM indicator continues to be ON. Press the RESET switch, the BUZZER and ALARM indicator light will turn OFF.

Q & A FG-A1 Backup System

Q. The red and yellow LED's flash on my control panel. What's wrong?

A. Maybe nothing at all! A slow flash rate, (about 1 second, or less), indicates that the charging system has nearly charged the battery to its optimum charge level. The flashing LED's should slow and eventually stop when the battery is completely charged.

A fast LED flash rate (more than 2 per second) indicated the 1 A charging fuse has blown, the battery leads are reversed or the wall transformer is not supplying proper voltage to the control box. Check the battery connections, then replace the fuse. If the LED's continue to fast flash, check the 115V outlet for proper current and replace the plug-in wall transformer, if necessary. A severely discharged battery may also cause a surge in the system and blow the fuse if connected.

Q. When I hooked up the system, the yellow charging light came on. Why? The battery was supposed to be fully charged when I got it.

A. A new battery, although charged adequately to start most engines, will not be charged to its full/optimum level. The charging system supplied with your pump monitors the charge level and slowly charges the battery to its optimum level.

Q. OK, after 2 days, the LED's are blinking between "charged and charging." What's wrong now?

A. Probably nothing; see question 2 above. The system normally takes 2-3 days to fully charge a good battery from about 11.9 VDC to 14.4 VDC. As the battery approaches full charge, the

LED's will alternate between "CHARGED" & "CHARGING."

Q. Finally, the LED's quit alternating and the "CHARGED" LED came on, but every once in a while the "CHARGING" LED comes on for just a second or two, then goes out. Is my system OK?

A. Yes! No need to worry. It is normal for a battery to lose some of its charge (decay) when idle. Our charging system monitors the charge state and turns itself on to boost the battery backup to its optimum charge. This usually takes from a few seconds to a few minutes.

Q. We came home late one evening and heard our battery backup alarm sounding. The pump wasn't running. What's wrong?

A. It is possible that the primary pump failed to operate when needed and your backup pump activated and drained the tank. The alarm activates any time the pump is called to operate. It continues to operate until the alarm condition is manually acknowledged by pressing the reset switch.

Q. Pressing the reset switch didn't silence the alarm. Now what?

A. The alarm circuit is activated so long as the float switch is activated. Check to see if the backup float switch is tangled or caught in the sump or piping. Remember to disconnect all power before servicing.

Q. The float wasn't tangled, but the alarm continues to pulsate.

A. A pulsating alarm is different from a steady tone. The pulsing alarm indicated that the battery voltage has dipped below an acceptable level. As a precaution, the charging circuit is locked out when this occurs, just in case one or more cells have shorted. It will

be necessary to remove the battery and have it charged on a commercial automotive or marine battery charger, per the manufacturer's instructions. Once the battery voltage can be sustained above 11.9 VDC, the battery can be reinstalled in the system and the on-board charging circuit can again be used to maintain the battery charge.

Q. When I got my system home and prepared to install it, I found out that the pump cable, sensor and charging cord were too short to reach the control box. Can I splice the leads so that they will reach?

A. No! The cable lengths were all designed around optimum operating parameters and are at a maximum length for their given sizes. Since the charger and pump are microprocessor (computer) controlled, changing the cable lengths may affect critical computer inputs which could cause the system to malfunction and may even present a fire hazard.

Q. I couldn't install my battery backup pump above my primary pump per your instructions, because my sump is too shallow. Will it matter if it is installed BESIDE my primary pump?

A. Yes. Installing a backup pump in the sump beside the primary pump could spell disaster. Sediment will accumulate inside the backup pump and may cause it to fail when needed most. The backup pump must be installed above the normal turn-on level of the primary pump. You may need to modify or replace your sump if it is too small. A minimum 30" deep sump is recommended. Remember, the backup pump must also be tilted at a 30 degree angle to operate properly. (It may air bind if not tilted.)

Q & A FG-A1 Back-Up System

Q. Why is it necessary to install the pump at an angle?

A. Installing the pump at an angle prevents air from entering the system. If air were allowed to enter the system, the pump would not operate.

Q. What is a trickle charger?

A. A trickle charger is a device that allows the battery to charge the pump system constant until the battery is fully charged.

Q. Can a backup sump pump be used with a pedestal sump pump?

A. Yes. However, your sump basin must be at least 18" in diameter, and an additional piece of PVC pipe must be used to extend the pump tee so the backup pump will not interfere with the float rod of the pedestal pump.

Q. The pump is buzzing but not pumping. What's wrong?

A. There are several reasons why this situation might occur: A) The system is air locked. Make sure the pump is positioned at the recommended 30 degree angle. B) Your battery is low. If the low-battery light is lit on the control box, make sure your battery is properly charged. C) The system may be clogged with debris. Make sure pipes are not plugged, and that the pump openings are clear.

Q. What size fuse is required?

A. A 12 amp fuse for the RED (Positive) battery lead.

Q. What type of battery should be used?

A. We recommend a deep cycle (marine) battery 650 CCA with 105 AH rating.

FG-A1 Parts List

| Ref. No. | Description | Qty. Req'd. | Part No. |
|----------|---|-------------|-----------|
| 1 | Sump Pump | 1 | 149530001 |
| 2 | Battery Box | 1 | 149530041 |
| 3 | Panel Control | 1 | 149530031 |
| 4 | Tee Adapter | 1 | 149530011 |
| 5 | Battery Charger | 1 | 149530061 |
| 6 | Level Control | 1 | 149530021 |
| 7 | Battery Cable Clamp Assembly Not Shown | 1 | 149530051 |

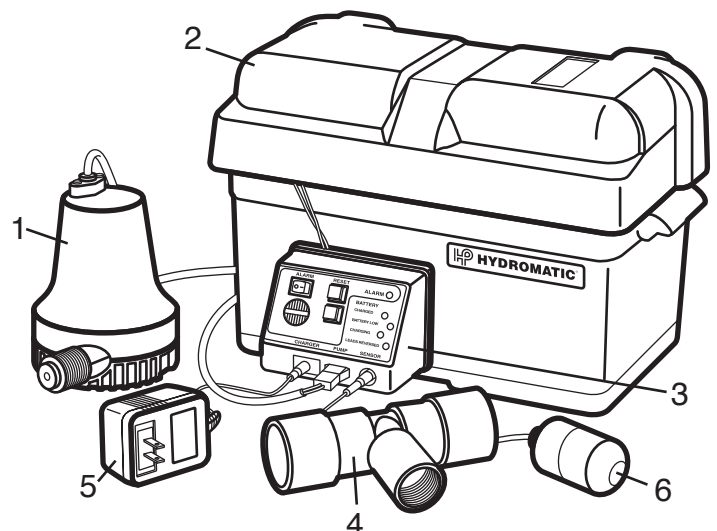

WARRANTY

Hydromatic® warrants to the original purchaser of each Hydromatic product(s) that any part thereof that proves to be defective in material or workmanship within one year from date of installation or 18 months from manufacture date, whichever comes first, will be replaced at no charge with a new or remanufactured part, F.O.B. factory. Purchaser shall assume all responsibility and expense from removal, reinstallation and freight. Any item(s) designated as manufactured by others shall be covered only by the express warranty of the manufacturer thereof. This warranty does not apply to damage resulting from accident, alteration, design, misuse or abuse. The pump must be installed, operated and maintained in accordance with the published instructions of the appropriate Installation & Service Manual.

All dual seal non-clogs and 3–5 HP grinders must have seal failure and heat sensors attached and functional for Warranty to be in effect. If a seal failure should occur, Hydromatic will cover only the lower seal and labor thereof. Labor is based on Authorized Service Center contract allowance. If the heat sensor is not attached and functional, Warranty is void. If the seal failure sensor is not attached and functional, Warranty is void.

If the material furnished to the Buyer shall fail to conform to this contract or to any of the terms of this written warranty, Hydromatic shall replace such nonconforming material at the original point of delivery and shall furnish instruction for its disposition. Any transportation charges involved in such disposition shall be for the Buyer's account. The Buyer's exclusive and sole remedy on account or in respect of the furnishing of material that does not conform to this contract or to this written warranty, shall be to secure replacement thereof as aforesaid. Hydromatic shall not in any event be liable for the cost of any labor expended on any such material or for any incidental or consequential damages to anyone by reason of the fact that such material does not conform to this contract or to this written warranty.

ALL IMPLIED WARRANTIES, INCLUDING THE IMPLIED WARRANTY OF MERCHANTABILITY AND THE IMPLIED WARRANTY OF FITNESS FOR A PARTICULAR PURPOSE, ARE DISCLAIMED TO THE SAME EXTENT AS THE EXPRESS WARRANTY CONTAINED HEREIN. Some states do not allow limitations on how long an implied warranty lasts, so the above limitation may not apply to you.

MANUFACTURER EXPRESSLY DISCLAIMS AND EXCLUDES ANY LIABILITY FOR CONSEQUENTIAL OR INCIDENTAL DAMAGES FOR BREACH OF ANY EXPRESS OR IMPLIED WARRANTY ARISING IN CONNECTION WITH THIS PRODUCT, INCLUDING WITHOUT LIMITATION, WHETHER IN TORT, NEGLIGENCE, STRICT LIABILITY CONTRACT OR OTHERWISE. Some states do not allow the exclusion or limitation of incidental or consequential damages, so the above limitation or exclusion may not apply to you. This warranty gives you specific legal rights, and you may also have other rights which vary from state to state.



USA

740 East 9th Street, Ashland, Ohio 44805
Tel: 419-289-3042 Fax: 419-281-4087

www.hydromatic.com

– Your Authorized Local Distributor –

CANADA

269 Trillium Drive, Kitchener, Ontario, Canada N2G 4W5
Tel: 519-896-2163 Fax: 519-896-6337

Free Manuals Download Website

<http://myh66.com>

<http://usermanuals.us>

<http://www.somanuals.com>

<http://www.4manuals.cc>

<http://www.manual-lib.com>

<http://www.404manual.com>

<http://www.luxmanual.com>

<http://aubethermostatmanual.com>

Golf course search by state

<http://golfingnear.com>

Email search by domain

<http://emailbydomain.com>

Auto manuals search

<http://auto.somanuals.com>

TV manuals search

<http://tv.somanuals.com>