

PENTAX™

Digital Camera

Optio 33*L*

Operating Manual

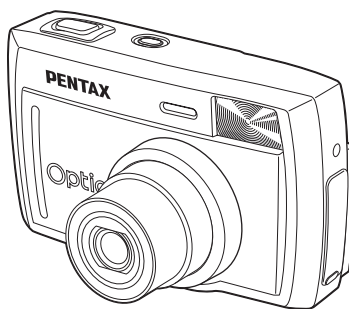

For optimum camera performance,
please read the Operating Manual
before using the camera.

Thank you for buying the PENTAX Optio 33L Digital Camera. Please read this manual before using the camera in order to get the most out of all the features and functions. Keep this manual safe, as it can be a valuable tool in helping you to understand all the camera's capabilities.

Regarding copyrights

Images taken using the Optio 33L that are for anything other than personal enjoyment cannot be used without permission according to the rights as specified in the Copyright Act. Please take care, as there are even cases where limitations are placed on taking pictures even for personal enjoyment during demonstrations, industrial enterprise or as items for display. Images taken with the purpose of obtaining copyrights also cannot be used outside the scope of use of the copyright as laid out in the Copyright Act, and care should be taken here also.

Regarding trademarks

- CompactFlash and CF are trademarks of SanDisk Corporation.
- PENTAX is a trademark of PENTAX Corporation.
- Optio is a trademark of PENTAX Corporation.
- All other brands or product names are trademarks of registered trademarks of their respective companies.
- The USB driver uses software developed by inSilicon Corporation.
Copyright © 2002 inSilicon Corporation. All rights reserved.
- This product supports PRINT Image Matching II.
When used in combination, PRINT Image Matching II enabled digital still cameras, printers and software help photographers to produce images more faithful to their intentions.
Copyright 2001 Seiko Epson Corporation. All Rights Reserved.
PRINT Image Matching is a trademark of Seiko Epson Corporation.

To users of this camera

- There is a possibility that recorded data may be erased or that the camera may not function correctly when used in surroundings such as installations generating strong electromagnetic radiation or magnetic fields.
- The liquid crystal panel used in the LCD display is manufactured using extremely high precision technology. Although the level of functioning pixels is 99.99% or better, you should be aware that 0.01% or fewer of the pixels may not illuminate or may illuminate when they should not. However, this has no effect on the recorded image.
- There is a possibility that the illustrations and the display screen of the LCD monitor in this manual are different from the actual product.

FOR YOUR SAFETY

We have paid close attention to the safety of this product. When using this product, we request your special attention regarding items marked with the following symbols.



Warning

This symbol indicates that violating this item could cause serious personal injury.



Caution

This symbol indicates that violating this item could cause minor or medium personal injury, or material loss.



Warning

- Do not disassemble or modify the camera. High voltage areas are present inside the camera, with the risk of electric shock.
- If the camera interior is exposed due to dropping or otherwise damaging the camera, never touch the exposed portion. There is the risk of electric shock.
- Wrapping the strap around your neck is dangerous. Take care that small children do not hang the strap over their necks.
- Always use the AC adapter specified exclusively for this product, with the specified power and voltage. Using an AC adapter not exclusive to this product, or using the exclusive AC adapter with an unspecified power or voltage can cause a fire, electric shock, or camera breakdown.
- If any irregularities occur during use, such as smoke or a strange odor, stop use immediately, remove the batteries or the AC adapter, and contact your nearest PENTAX service center. Continued use could cause a fire or electric shock.
- During thunderstorms, unplug and discontinue use of the AC adapter. Continued use could cause equipment failure, a fire, or electric shock.



Caution

- Do not short the battery or dispose of the battery in fire. Do not disassemble the battery. The battery could explode or catch fire.
- Do not charge any batteries other than rechargeable Ni-MH batteries. The battery could explode or catch fire. Of the batteries that can be used in this camera, only the Ni-MH battery can be recharged.
- Remove the battery from the camera immediately if it becomes hot or begins to smoke. Be careful not to burn yourself during removal.
- Some portions of the camera heat up during use. There is the risk of low temperature burns when holding such portions for long periods.

Handling the Camera

- Always confirm that the camera is working properly when the camera has not been used for a long time, or before important occasions (weddings, trips, etc.). PENTAX is not responsible for consequential damages (costs incurred for photography, lost profits, etc.) arising from failure of this product.
- The lens on this camera is not exchangeable. The lens is not removable.
- Do not clean the product with organic solvents such as thinner, alcohol, or benzene.
- Do not subject to high temperatures or high humidity. Do not leave the camera in a vehicle, as the temperature can get very high.
- Do not store the camera with preservatives and chemicals. Storage in high temperatures and high humidity can cause molding. Remove from case and store in a dry and well-ventilated location.
- This camera is not waterproof, and cannot be used in the rain or where the camera could get wet.
- Do not subject the camera to strong vibrations, shocks, or pressure. Use a cushion to protect the camera from vibrations of motorcycles, automobiles, or ships.
- The temperature range for camera use is 0°C to 40°C.
- The LCD display may appear black under high temperatures, but will return to normal as temperatures normalize.
- The LCD display may respond more slowly at low temperatures. This is due to liquid crystal properties, and is not a fault.
- Periodic inspections are recommended every one to two years to maintain high performance.
- Sudden temperature changes will cause condensation on the inside and outside of the camera. Place the camera in your bag or a plastic bag, retrieving the camera after decreasing the temperature difference.
- Avoid contact with garbage, mud, sand, dust, water, toxic gases, or salts. These could cause a camera breakdown. Wipe dry any rain or water drops on the camera.
- See "Precautions When Using a CF Card" (p.16) for details on the compact flash memory card (CF Card).
- Please do not press forcefully on the LCD monitor. This could cause breakage or malfunction.
- When you rotate the LCD monitor, please rotate it carefully in the correct direction, and do not apply excessive force. This could damage your camera.

Contents

FOR YOUR SAFETY	3
Handling the Camera	4
Contents	5
Contents of This Manual	7
Checking Package Contents	8
Names of Parts	9
Names of Operating Parts	10
Getting Started	11
Attaching the Strap	11
Powering the Camera	12
Installing the Batteries	12
Using the AC Adapter	14
Installing/Removing the CF Card	15
Rotating the LCD Monitor (Rotate LCD)	17
Initial Settings	18
Setting the Display Language	18
Setting the Home Town	18
Setting the D.S.T. Mode	19
Setting the Video Output Format	19
Setting the Date and Time	20
Quick Start	22
Taking Still Pictures	22
Playing Back Still Pictures	24
Playing Back Images	24
Playing Back Previous or Next Images	24
Using Your CF Card	26
Common Operations	29
Turning the Camera On and Off	29
Playback Only Mode	29
Using Button Functions	30
Capture Mode	30
Playback Mode	31
Setting the Menus	32
How to Set the Menus	32
Menu List	34
Taking Pictures	36
Setting the Capture Functions	36
Changing Focus Settings	36
Selecting the Flash Mode	38
Selecting the Recorded Pixels	39
Selecting the Quality Level	40
Adjusting the White Balance	41
Setting the Focusing Area	43
Setting the Light Metering Range	44
Setting Sensitivity	45
Setting the Instant Review Time	46
Setting Image Sharpness	46
Setting Color Saturation	47
Setting the Image Contrast	47
Switching Between Modes	48

Switching Between Capture Mode and Playback Mode	48
Selecting the Capture Mode	48
Taking Pictures.....	49
Program Mode	49
Picture Mode	50
Taking Self-Portraits	52
Taking Dark Scenes (Night-Scene Mode)	53
Taking Movie Pictures (Movie Picture Mode)	54
Taking Panorama Pictures (Panorama Assist Mode)	56
Taking 3D Pictures (3D Image Mode).....	58
Taking Pictures with Digital Filters (Digital Filter Mode).....	63
Automatically Change Capture Conditions (Auto Bracket Mode)	64
Continuous Shooting (Continuous Shooting/High-Speed Shooting).....	66
Using the Self-Timer	67
Using the Zoom.....	68
EV Compensation.....	70
Saving the Settings.....	72
Saving the Menu Items (Memory).....	72
Playback/Deleting	74
<hr/>	
Playing Back Images.....	74
Playing Back Still Pictures	74
Zoom Playback	74
Playing Back Movie Pictures.....	75
Nine Image Display.....	76
Slideshow.....	77
Deleting Images.....	78
Deleting a Single Image.....	78
Deleting All Images.....	78
Protecting Images from Deletion (Protect).....	79
Viewing Images on a TV	80
Printing Service Settings (DPOF)	81
Single Image Settings.....	81
Settings for All Images	83
Settings	84
<hr/>	
Camera Settings.....	84
Formatting a CF card	84
Changing the Display Language	85
Changing the Date Style and Date/Time	85
Selecting the Video Output Format.....	86
Turning the Operation Sound On and Off	86
Setting World Time	87
Setting the Display Mode.....	88
Screen Effect	90
Setting the Background Color.....	90
Setting Auto Power Off	91
Setting LCD Monitor Brightness.....	91
Resetting to Default Settings [Reset]	91
Appendix	92
<hr/>	
List of City Names.....	92
Messages	93
Troubleshooting.....	94
Optional Accessories.....	96
Main Specifications.....	97
WARRANTY POLICY	99

Contents of This Manual

This operating manual contains the following chapters.

1 Getting Started

Explains your first steps, from purchasing the camera to taking pictures. Be sure to read it and follow the instructions.

2 Quick Start

Explains the simplest way to take pictures and play back images. Use it if you want to get started right away. It also explains how to use the CF card.

3 Common Operations

Explains common operations such as button functions and using the menus. See "Taking Pictures", "Playback/Deleting", and "Settings" chapters for more details.

4 Taking Pictures

Explains various ways to capture images, and how to set the relevant functions, such as setting the virtual mode dial to change capture modes, and selecting the right picture mode for the current scene.

5 Playback/Deleting

Explains how to play back images on the camera or a TV, and how to delete.













6 Settings

Explains setting camera functions.

7 Appendix

Explains troubleshooting, and introduces accessories sold separately.

The symbols used in this operating manual are explained below.

	Shows reference page number explaining a related operation.
	Shows information useful to know.
	Shows precautions to take when operating the camera.
 , Picture Mode,  ,  ,  ,  ,  ,  ,  , 	Icons for functions available in a capture mode are shown at the beginning of a section.

Checking Package Contents



Camera
Optio 33L

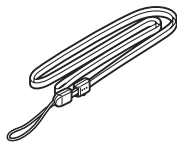

Strap
O-ST5(*)

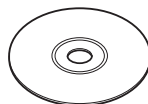

Software
(CD-ROM)
S-SW8



Video cable
I-VC2(*)

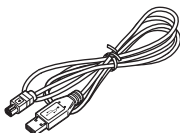

USB cable
I-USB2(*)

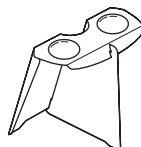

3D image viewer
O-3DV1

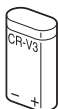

Lithium battery
CR-V3

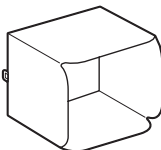

LCD monitor hood



Operating Manual
(this manual)

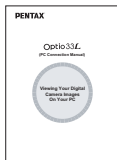

Operating Manual
(PC Connecting Manual)

* Items marked with an asterisk are also available as optional accessories. For other optional accessories, see "Optional Accessories" (p.96).

Names of Parts

Front

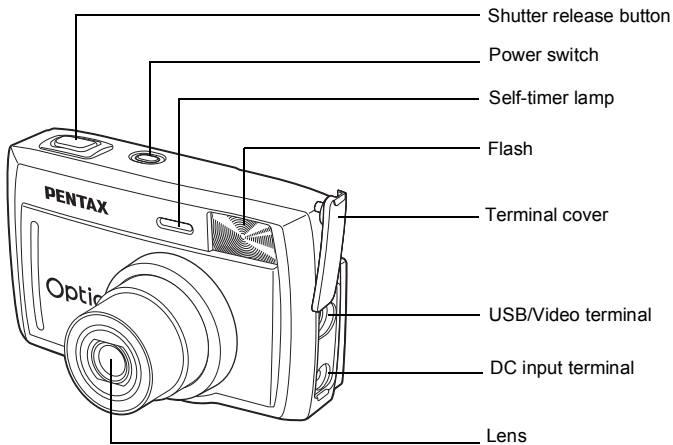

Back

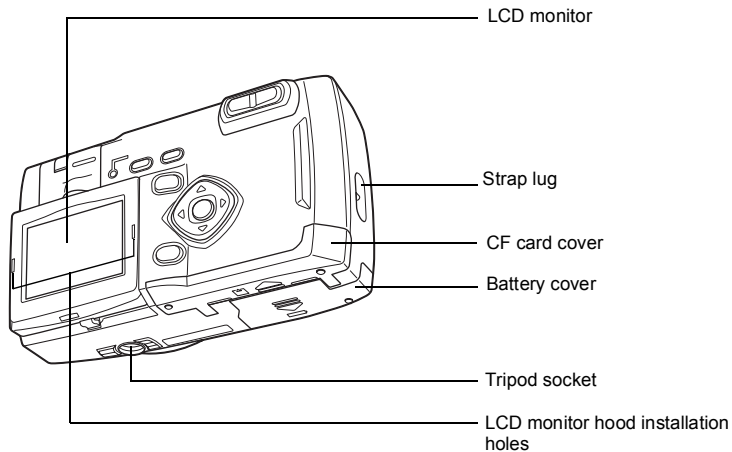

Names of Operating Parts

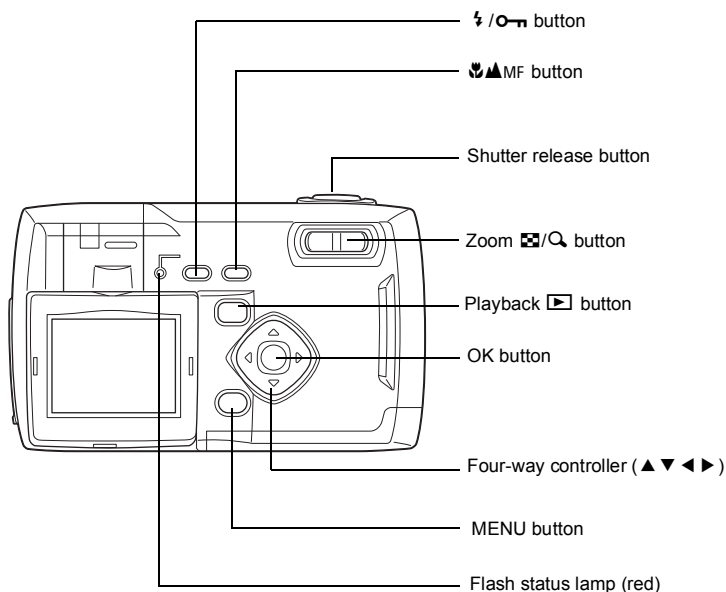

Guide display

A button operation guide is displayed on the LCD monitor during operation.

The buttons are indicated as shown below.

Four-way controller ()		MENU button	
Four-way controller ()		Zoom / button (Digital zoom and magnified playback only)	
Four-way controller ()		button	
Four-way controller ()		button	
OK button			

Attaching the Strap

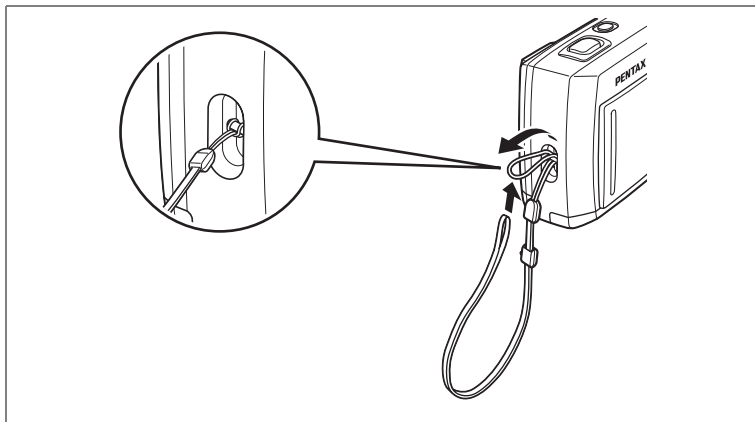

Pass the narrow end of the strap through the strap lug, and attach as shown.

Powering the Camera

1

Getting Started

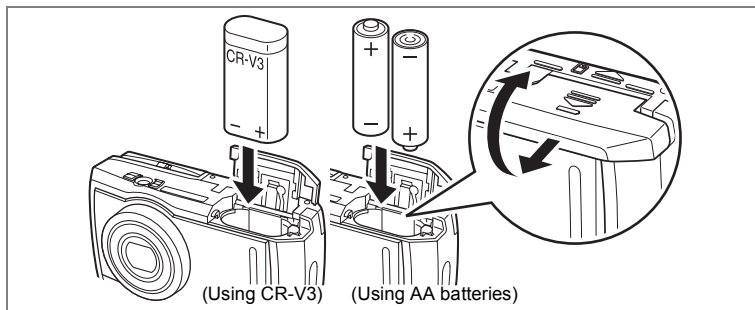

Installing the Batteries

Install batteries in the camera. Use one CR-V3, or use two AA lithium batteries, AA Ni-MH batteries, or AA alkaline batteries.

- 1 Slide the battery cover in the direction indicated, and flip open.**
- 2 Insert the batteries according to the +/- indicator in the battery chamber.**
- 3 Close the battery cover and push horizontally to lock.**



When using for a prolonged period, please use the AC adapter kit D-AC5. (p.14).



- CR-V3 (battery included), AA lithium batteries, and AA alkaline batteries are not rechargeable.
- Do not open the battery cover or remove the batteries when the power switch is on.
- When you will not use the camera for a long while, remove the batteries. Otherwise, the battery may leak.
- If the date and time settings have been reset when you insert new batteries after a long while, follow the procedure for "Setting the Date and Time" (p.20).
- Insert batteries correctly. Batteries inserted backwards can cause a camera breakdown.

Number of Captures and Playback Time (room temperature, new batteries)

		Number of recordable images	Playback time
With the flash fired for 50% of the shots	CR-V3	Approx. 650	Approx. 450
	AA lithium	Approx. 400	Approx. 300
	AA Ni-MH	Approx. 270	Approx. 200
	AA alkaline	Approx. 70	Approx. 70

- These figures are based on PENTAX measuring conditions. May vary by capture mode or shooting conditions.



- Battery performance temporarily decreases as the temperature decreases. When using the camera in cold climates, have extra batteries on hand, keeping them warm in your pocket. Battery performance will return to normal when returned to room temperature.
- AA alkaline batteries may not adequately handle all the camera functions. We do not recommend their use except in emergencies.
- When traveling overseas, taking pictures in cold climates, or when you will be taking a lot of pictures, please have extra batteries ready.

Battery Level Indicator

You can check the battery level on the LCD monitor.

	(lit green)	: Plenty of battery power
↓		
	(lit yellow)	: Battery running low
↓		
	(lit red)	: Battery almost gone
↓		
[Battery Depleted]		: After displaying this message, the camera turns off.

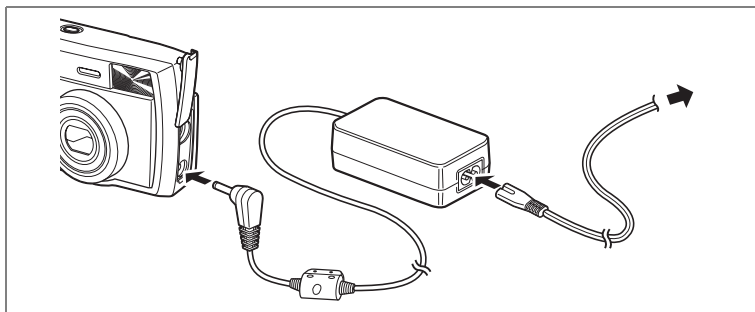

Using the AC Adapter

When using the LCD monitor for a long time or when connecting to your PC, we recommend using the AC adapter kit D-AC5 (sold separately).

- 1 Make sure the camera is turned off before opening the terminal cover.**
- 2 Connect the DC terminal on the AC adapter to the DC input terminal on the camera.**
- 3 Connect the AC plug cord to the AC adapter.**
- 4 Plug into the power outlet.**

Caution

- Make sure the camera is turned off before connecting or disconnecting the AC adapter.
- Make sure connections are secure between the camera, AC adapter, AC plug cord terminal, and the power outlet. Disconnections while the camera is recording or reading data on the CF card will corrupt your data.
- When using the AC adapter, be sure to read the AC adapter D-AC5 operating manual.
- Connecting the AC adapter will not charge the rechargeable batteries in your camera.

Installing/Removing the CF Card

1

Getting Started

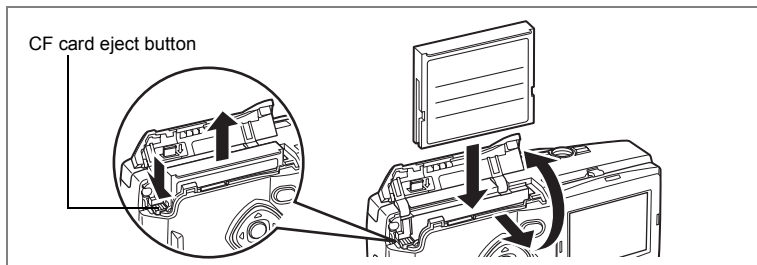

Captured images are recorded on the compact flash (CF) card. Make sure the camera is turned off before installing or removing a CF card (market product).

Installing

- 1 Slide the CF card cover in the ↘ direction, and flip open.
- 2 Insert the card all the way with the CF card label (or ▲ symbol) toward the lens.
- 3 Close the CF card cover.

Removing

- 1 Slide the CF card cover in the ↘ direction, and flip open.
- 2 Press the CF card eject button and remove the card.
- 3 Close the CF card cover.



- If the CF card cover is opened with the power on, a warning will sound and the camera will automatically be turned off.
- If the CF card cover is opened while saving an image, the save is interrupted (the image is not saved).

15

• Approximate Number of Shots, Recorded Pixels, and Quality Levels

Quality Level \ Recorded Pixels	Best ★★★	Better ★★	Good ★	Movie images (320 × 240)
2048 × 1536	8	16	33	30 sec × 2 sets
1600 × 1200	13	27	60	
1024 × 768	24	50	89	
640 × 480	50	89	128	

- These figures show the number of shots when using a 16MB CF card.
- These figures are based on PENTAX standard shooting conditions, and may vary depending on the subject, shooting conditions, capture mode, and CF card used.

Precautions When Using a CF Card

- Make sure the camera is turned off before opening the CF card cover.
- The CF card may be hot when removed immediately after camera use. Please be careful.
- Never open the CF card cover or turn off the camera while recording data on the CF card, during image playback, or while connected to a PC with a USB cable. This could cause data loss or card damage.
- Do not bend the CF card or subject it to violent impact. Do not get it wet or leave it in a high temperature location.
- New cards or cards used in another camera must be formatted before use. See "Formatting a CF card" (p.84) for formatting.
- Never open the CF card cover while formatting a CF card. The card may be damaged beyond use.
- Data saved on a CF card may be erased under the following conditions. PENTAX does not accept any liability regarding erased data.
 - When the user mishandles the CF card
 - When the CF card is placed in a location with static electricity or electrical interference
 - When the card is not used for a long time
 - When the card, the AC adapter, or battery is removed while recording or reading data on the CF card
- The CF card has a limited life. The stored data may become unreadable after long periods of disuse. Please periodically backup important data onto your PC.
- Please avoid using or storing your card where static electricity or electrical interference can occur.
- Do not use or store your card where it may be exposed to sudden temperature changes, condensation, or direct sunlight.

Rotating the LCD Monitor (Rotate LCD)

1

You can rotate the LCD monitor 180° vertically or horizontally. The screen display will change with the rotation of the LCD monitor. When taking your self-portrait, you can check the screen while you take the picture. The screen display changes with the rotation of the LCD monitor (mirror image).

- Pull the LCD monitor upward.

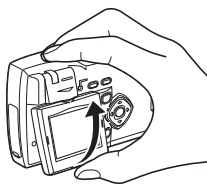

- You can rotate the monitor 180° horizontally.

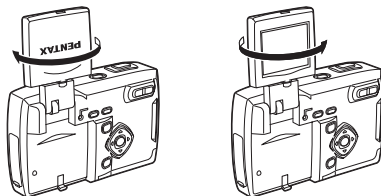

- When the LCD monitor is hard to see, such as in bright sunlight, install the supplied LCD monitor hood.

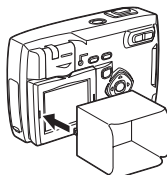

When your digital camera is not in use, protect your LCD monitor by rotating it to the back (PENTAX logo is on the front) for storage.



- When attaching or removing the LCD monitor hood, please return the LCD monitor to its stowed position, to prevent undue force on the LCD monitor rotation hinge.
- When rotating the LCD monitor, do not apply excessive force.

Initial Settings

1

Getting Started

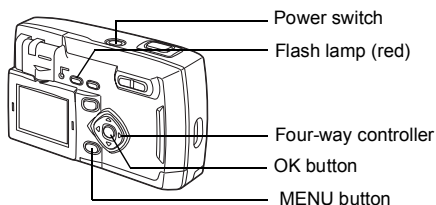

Setting the Display Language

You can choose the language in which the menus, error messages, etc. are displayed from the following: English, French, German, Spanish, Italian and Japanese.

- 1 Turn the camera on.**
- 2 Use the four-way controller (◀▶) to select the display language.**

The default setting is English.

- 3 Press the four-way controller (▼).**

The screen for setting the next item will be displayed.

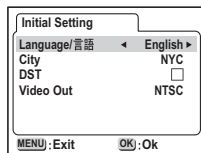

- You can change the setting after it has been made. Refer to “Changing the Display Language” (p.85).

Setting the Home Town

You can choose the city (Home Town) in which you will use the camera.

- 1 Press the four-way controller (◀▶) to select the desired city (Home Town).**

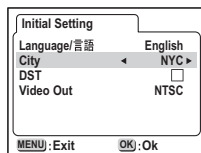

2 Press the four-way controller (▼).

The screen for setting the next item will be displayed.



- See p.92 for the list of cities and corresponding code names.
- You can change the setting after it has been made. Refer to “Setting World Time” (p.87).

Setting the D.S.T. Mode

You can choose whether or not to display the D.S.T (Daylight Saving Time) mode.

1 Use the four-way controller (◀▶) to select (On) or (Off).

The default setting is (Off).

2 Press the four-way controller (▼).

The screen for setting the next item will be displayed.

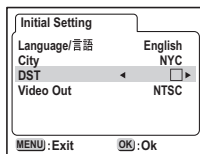

- You can change the setting after it has been made. Refer to “Setting World Time” (p.87).

Setting the Video Output Format

You can choose the output format (NTSC or PAL) for taking or playing back pictures using a TV monitor.

1 Use the four-way controller (◀▶) to select the video output format.

The default setting is NTSC.

2 Press the Playback/OK button.

The screen for setting the date and time will be displayed.

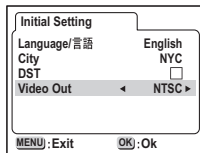

- You can change the setting after it has been made. Refer to “Selecting the Video Output Format” (p.86).

Setting the Date and Time

Set the current date and time, and the display style.

- 1 Press the four-way controller (▲▼) to select the date and time display style.**

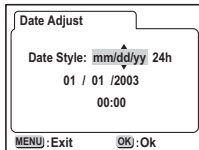

- 2 Press the four-way controller (▶).**

▲▼ are displayed above and below "24h".

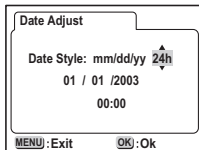

- 3 Press the four-way controller (▲▼) to select 24h (24-hour display) or 12h (12-hour display).**

- 4 Press the four-way controller (▶).**

▲▼ is displayed above and below the month.

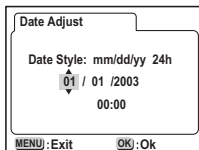

- 5 Press the four-way controller (▲▼) to change the month.**

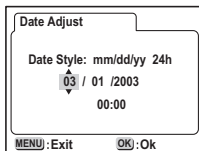

- 6 Press the four-way controller (▶).**

▲▼ are displayed above and below the date.

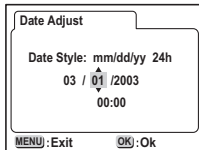

7 Press the four-way controller (▲▼) to set the date and press the four-way controller (▶) again.

▲▼ are displayed above and below the year.

8 Repeat step 7 to set the year, hour, and minutes.

9 Press the OK button.

The camera is ready to take a picture. When you set the date and time using the MENU button, you will return to the Menu screen. Press the Playback/OK button again.



- If you press the MENU button before initial settings are complete, your settings will be cancelled, but you can take pictures. If this happens, the Initial Settings screen is displayed the next time the camera is turned on.
- Your settings can be changed later from the Menu screen. To access the menu, see “Changing the Date Style and Date/Time” (p.85)

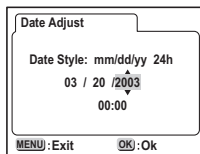

Taking Still Pictures

2

Quick Start

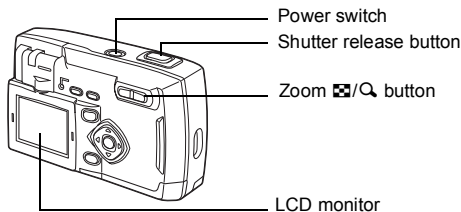

This is the simplest way to take still pictures. The flash discharges automatically based on light conditions by the default setting.

1 Press the power switch.

The camera will turn on.

2 Confirm the subject and shooting information on the LCD monitor.

The focus frame at the center of the LCD screen indicates the zone of automatic focusing. Press the Zoom button to change the size of the subject.

- ⬆ Subject becomes bigger.
- ⬇ Subject becomes smaller.

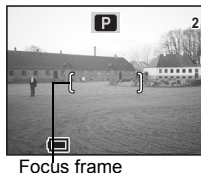

3 Press the shutter release button.

The captured image is displayed on the LCD monitor for 0.5 seconds (instant review). The image is saved on the CF card (The red lamp blinks while saving).

Pressing the Shutter Release Button

The shutter release button works in two steps.

• Press halfway

Lightly press (halfway) the shutter release button to lock the focus position, exposure, and white balance.

- The shutter speed and aperture settings are only displayed when pressing the shutter release button halfway.
- The following information is shown on the LCD monitor and flash status lamp.

1. Focus frame

The frame lights green when focused. It is not displayed when out of focus.

2. Flash lamp status

	Flash status lamp (red)
Lit	Flash is ready
Blink	Charging

You cannot take a picture while the flash is charging.

• Press down fully

Press the shutter release button all the way down (fully) to take a picture.

Instant Review

The Instant Review default setting is 0.5 sec.

- Pressing the  button during Instant Review displays the Delete menu.
- Select [Delete] and press the OK button to delete the image.

Setting the Instant Review Time  p.46
--

Playing Back Still Pictures

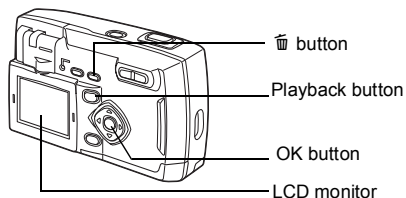

2

Quick Start

Playing Back Images

To play back still pictures:

- 1 Press the playback button after taking a picture.**

The captured image is displayed on the LCD monitor.

Pressing the four-way controller (▼) will rotate the image 90°, 180°, and 270°.

You can display images taken vertically for easy viewing.



Playing Back Previous or Next Images

You can play back still pictures, cycling through one at a time.

- 1 Press the playback button after taking a picture.**

The captured image is displayed on the LCD monitor.

- 2 Press the four-way controller (◀▶).**





Displays the previous image.



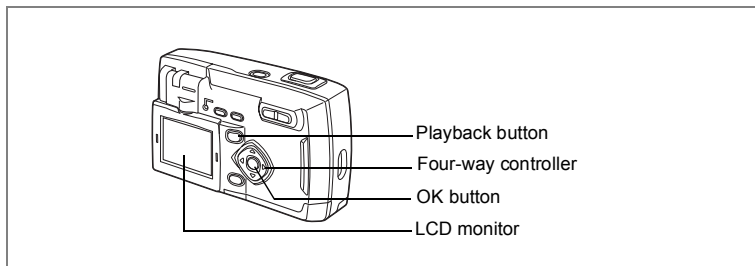

Displays the next image.

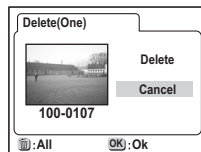

Deleting a Displayed Image

While the image is displayed, press the  button to display the Delete screen. Press the four-way controller () to select Delete, and press OK. The image is deleted. Press the Playback button again, or press the shutter release button halfway to return to capture mode.



- When you switch to the playback screen, the image with the highest file number is shown first.
- You can enlarge the image displayed on the LCD monitor by pressing the zoom// button.
- For movie pictures, the first frame is displayed.
- If no images are stored, the "No Image" message is displayed.

Zoom Playback  p.74

Using Your CF Card

Pictures taken with this camera are recorded on the compact flash (CF) card. You can view the pictures recorded on the CF card on the camera itself, transfer them to your PC, or print them.



Viewing Images on the Camera

One advantage of a digital camera is that you can check the picture as soon as you take it. You can check the composition and brightness, and take a picture again if you are not satisfied.

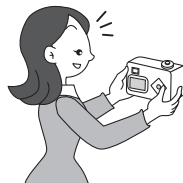

Playing Back Still Pictures  p.74

Viewing Images on a TV

Displaying your pictures on a TV is handy for those group occasions. To view the images, connect your camera to the TV with the video cable.

Viewing Images on a TV  p.80



Viewing Images on a PC

You only install the USB driver the very first time. After that, you simply connect the camera with the USB cable and read the images into your PC. You can view your pictures on you PC, or transfer the data and edit it. Or you can remove the CF card from the camera and transfer the data with a card reader. On a laptop, you can put a CF card in a card adapter and insert it into your card slot to transfer the image data. (When using other equipment to transfer your images from your CF card, please read the operating manual for your equipment.)

☞ Booklet: Viewing Your Digital Camera Images On Your PC



Printing Images at a Printing Service

You can order conventional photograph prints by taking the CF card with recorded images to a store with a printing service. DPOF (Digital Print Order Format) settings allow you to specify the number of copies or to include the date. Set these before taking your card to a store providing DPOF printing.

☞ Printing Service Settings (DPOF) ☞ p.81

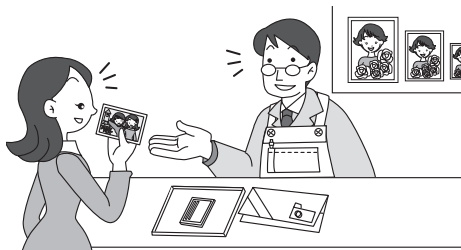

Turning the Camera On and Off

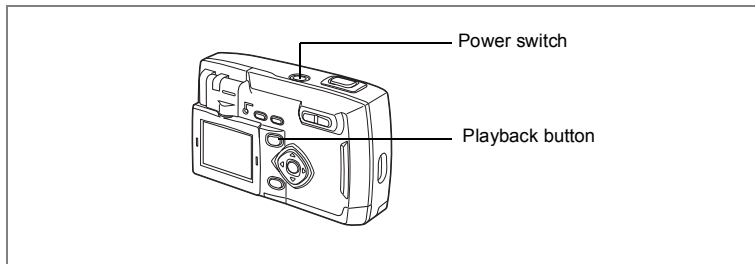

1 Press the power switch.

The camera will turn on. The lens cover opens and the lens extends. Press the power switch again to turn the camera off.

Playback Only Mode

Turning the camera on while pressing the Playback button activates the Playback Only mode.

- When the camera is started in Playback Only mode, the lens cover remains closed and the lens does not extend.
- To switch from Playback Only mode to Capture mode, turn the camera off and then turn it on again.

Playing Back Still Pictures  p.24

Using Button Functions

3

Common Operations

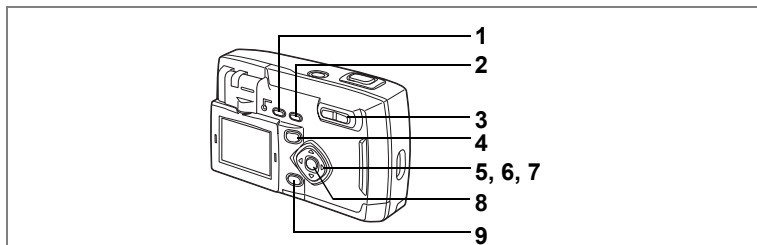

Capture Mode

1 **⚡ button**

Changes the flash mode. (☞ p.38)

2 **🌸▲MF button**

Changes the capture mode as follows. (☞ p.36)

Macro mode (☞ p.36)

Infinity-landscape mode (☞ p.36)

Manual focus mode (☞ p.36)

3 **Zoom button**

Changes the size of the subject. (☞ p.68)

4 **Playback button**

Switches to Playback mode. (☞ p.48)

5 **Four-way controller (◀▶)**

Changes the EV compensation. (☞ p.70)

6 **Four-way controller (▲)**

Selects continuous shooting mode or self-timer mode. (☞ p.66, 67)

7 **Four-way controller (▼)**

Displays the virtual mode dial and changes the capture mode. (☞ p.48)

8 **OK button**

Selects a menu item.

9 **MENU button**

Displays [Rec. Mode] and [Set-up] menus. (☞ p.32)

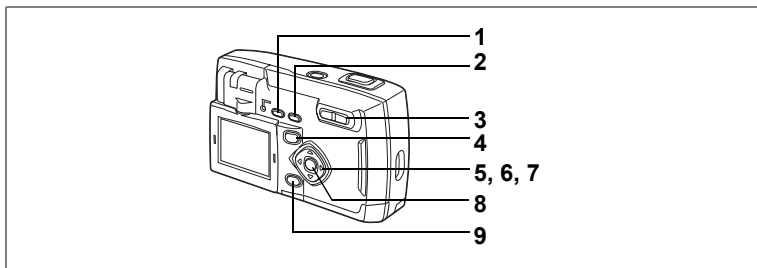

Playback Mode

- 1 Lock button**
Protects the image from deletion. (☞ p.79)
- 2 Delete button**
Deletes the image. (☞ p.78)
- 3 Zoom/☒/Q button**
Displays nine images at once when pressed in standard Playback mode.
Changes the image size on the LCD monitor in Zoom Display mode. (☞ p.74)
- 4 Playback/☒ button**
Switches to Capture mode.
- 5 Four-way controller (◀▶)**
Plays back previous or next image. (☞ p.24)
- 6 Four-way controller (▲)**
Sets DPOF settings. (☞ p.81)
- 7 Four-way controller (▼)**
Rotates the displayed image clockwise 90°, 180°, and 270°. (☞ p.24)
- 8 OK button**
Selects a menu item.
- 9 MENU button**
Displays Playback and Set-up menus. (☞ p.32)

Setting the Menu

Press the MENU button to display the menus on the LCD screen. With these you can set functions, save the settings, and change the camera settings.

How to Set the Menu

A button operation guide is displayed on the LCD monitor during menu operation.

3

Common Operations

1 Press the MENU button.

The menu screen is displayed. The current selection is displayed in a frame.

2 Press the four-way controller (◀▶).

Use the four-way controller (◀▶) to select the menu screen.

3 Press the four-way controller (▲▼) to select an item.

This ▲▼ moves the selection frame up and down.

4 Press the four-way controller (◀▶) to change the setting. Press the four-way controller (▶) to move to a Select screen if available.

When finished, press the OK button to return to the menu.

5 Press the OK button.

This saves the settings and returns to Capture or Playback mode.



Even after you press the OK button and close the menu screen, if the camera is turned off improperly (such as removing the batteries while the camera is on), your settings will not be saved.

Example of menu operation (Pressing the MENU button in Capture mode)

1 MENU button

[CAMERA] [Rec. Mode] Menu

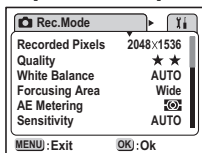

[Y] [i] [Set-Up] Menu

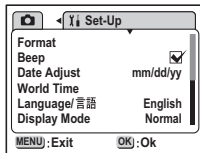

2

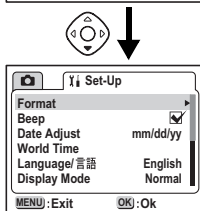
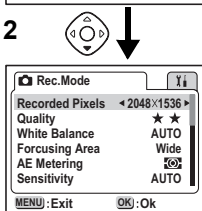

3

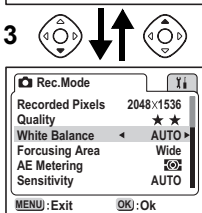

4

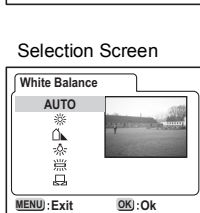

3

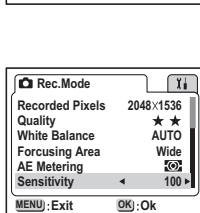
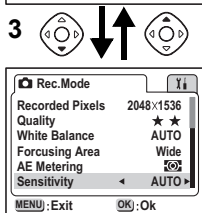

3



Next menu screen



If you press the shutter release button halfway or press the Zoom button to leave a menu screen, your settings will be saved and the camera returns to Capture mode (or the playback screen in Playback Only mode).

Menu List

[Rec. Mode] Menu

○...All changes are valid.

×...Setting changes are invalid.

Item	Description	Default Setting	Picture Mode  		Reference
Recorded Pixels	Selects the number of recorded pixels.	2048×1536		Set to 320×240	p.39
Quality Level	Selects the image compression rate.	★★		×	p.40
White Balance	Adjusts color balance according to lighting.	AUTO		○	p.41
Focusing Area	Changes the area for autofocus.	Wide		×	p.43
AE Metering	Sets the metering method to determine exposure.			○	p.44
Sensitivity	Sets sensitivity.	AUTO		×	p.45
Digital Zoom	For taking digital zoom pictures.	<input checked="" type="checkbox"/> (on)		○	p.69
Instant Review	Sets the Instant Review display time.	0.5s (0.5 sec)		○	p.46
Soft Setting	Adjusts the softness for soft mode in Picture mode.	 (normal)		×	p.51
EX. Bracket Step	Adjusts the bracket amount for Exposure Auto Bracket.	± 0.3 (EV)		×	p.65
WB Bracket Step	Adjusts the bracket amount for the White Balance Auto Bracket.	± 1		×	p.65
3D Mode	Sets 3D picture viewing method.	Parallel (Mode)		×	p.58
Memory	Saves the Rec. Mode settings when the camera is turned off.			×	p.72
Sharpness	Sets the sharpness.	 (normal)		×	p.46
Saturation	Sets the saturation.	 (normal)		×	p.47
Contrast	Sets the contrast.	 (normal)		×	p.47



Items marked with × can be changed on the menu screen, but are not reflected in actual operation.

[▶ Playback] Menu

Item	Description	Default Setting	Reference
Slide Show	Plays recorded images successively.	3s (3 sec. interval)	p.77

[ⓘ Set-up] Menu

Item	Description	Default Setting	Reference
Format	Formats a CF card	Cancel	p.84
Beep	Sets the button operation sound.	<input checked="" type="checkbox"/> (on)	p.86
Date Adjust	Sets the date and time.	mm/dd/yy	p.85
World Time	Sets world time.	<input type="checkbox"/> (off)	p.87
Language/言語	Switches the language for displaying menus and messages.	English	p.85
Display Mode	Switches the display mode in Capture Mode and Playback Mode.	Normal	p.88
Screen Effect	Displays on the LCD screen will transition smoothly.	<input checked="" type="checkbox"/> (on)	p.90
Video Out	Sets the video output format.	NTSC	p.86
Background Color	Sets the background color of the LCD screen.	Blue	p.90
Auto Power Off	Sets power conservation mode.	3m (3 minute)	p.91
Brightness Level	Sets brightness of LCD monitor.	Normal	p.91
Reset	Returns settings to defaults.	Cancel	p.91

Setting the Capture Functions

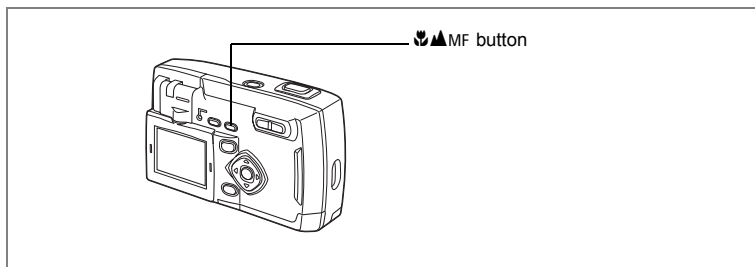

4 Changing Focus Settings

Focus Mode

(No icon)	Autofocus mode	Focuses on object in the focusing area when the shutter release button is pressed halfway. Use when the distance to the subject is more than 40cm.
⬇	Macro mode	Use when the distance to the subject is 10cm to 50cm. Focuses on object in the focusing area when the shutter release button is pressed halfway.
⬆	Infinity-landscape mode	Use for taking pictures of distant objects.
MF	Manual focus mode	Adjust focus manually.

1 Pressing **⬇⬆MF** in Capture mode will switch focus modes, and the current setting is displayed on the LCD monitor.

The camera is ready to take a picture in the set focus mode.



- The focus mode default setting is the Autofocus mode.
- In Movie Picture mode (see p.54), only Autofocus mode is available.
- In Picture mode (see p.50), Panorama Assist mode (see p.56), and 3D image mode (see p.58), Manual Focus mode cannot be set.

Manual Focus

On the MF setting, press the four-way controller (◀▶) to enlarge the central portion of the screen to full screen on the LCD monitor. Adjust the focus with the four-way controller while watching the image on the monitor.



For distant focus



For closer focus

Once the focus is set, press any button other than the four-way controller (◀▶), or take your finger off of the four-way controller for about 2 seconds. The camera will switch to the standard Capture screen.



- When focusing, hold down the four-way controller (◀▶) to focus quickly.
- Enlarged display is not available near maximum magnification in digital zoom.

Saving the Focus Mode  p.72

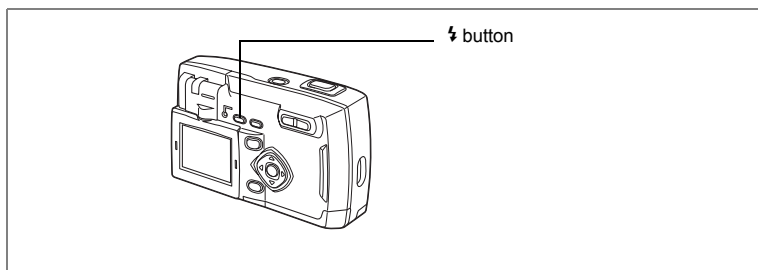

Selecting the Flash Mode

(No icon)	Automatic flash	The flash discharges automatically based on light conditions.
☺	Flash Off	The flash never discharges regardless of light conditions.
⚡	Flash On	The flash always discharges regardless of light conditions.
⚡ A	Auto flash + red-eye reduction	Reduces red-eye in the picture, caused by the flash reflecting from the subject's eyes. The flash discharges automatically.
⚡ ⊗	Flash On + red-eye reduction	Reduces red-eye in the picture, caused by the flash reflecting from the subject's eyes. The flash discharges regardless of lighting conditions.





- The flash is always off when the Capture mode is set on , Continuous shooting, or Infinity-Landscape.
- When using the flash, it always discharges once before taking the picture, to assist with metering.
- In Auto + red-eye reduction or Flash On + red-eye reduction, the flash discharges once before taking the picture to make the iris of the subject's eyes contract, shortly before firing again to take the picture.

1 Press the ⚡ button in Capture mode.

This will switch focus modes, and the current icon is displayed on the LCD monitor.

The camera is ready to take a picture in the selected flash mode.

Flash Lamp  p.23
Saving the Flash Mode  p.72

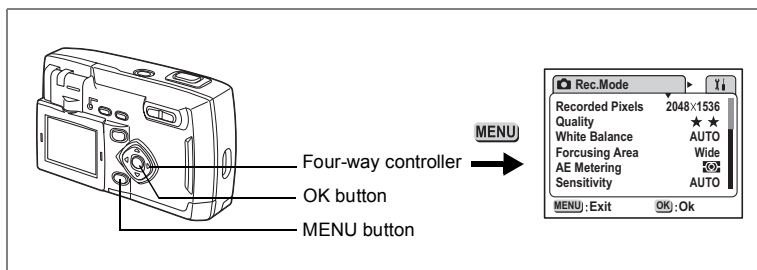

P Picture Mode     

Selecting the Recorded Pixels

Select the number of recorded pixels from 2048×1536, 1600×1200, 1024×768, 640×480.

The more pixels there are, the larger the image size and file size.

The image file size will also differ according to quality level settings.

2048×1536	Suited for printing on A4 paper.
1600×1200	Suited for printing on A5 paper.
1024×768	Suited for printing on postcards.
640×480	Suited for attaching to e-mail, or for creating websites.

- 1** Select [Recorded Pixels] on the [Rec. Mode] menu.
- 2** Press the four-way controller (◀▶) to change the recorded pixels.
- 3** Press the OK button.

The camera is ready to take a picture.

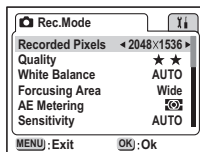

- The recorded pixels is fixed at 320×240 in Movie Picture mode.
- Selecting a large number of recorded pixels will result in a clearer image when printed.

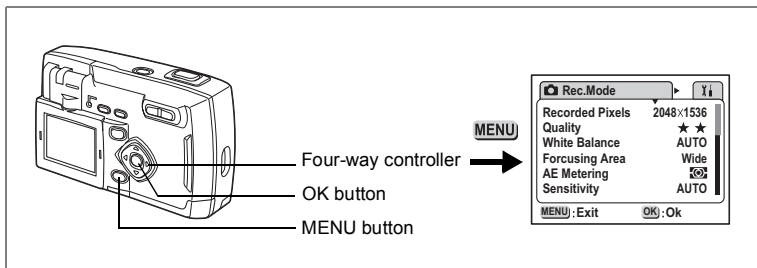

P Picture Mode      

Selecting the Quality Level

4 Select the image compression rate.

The more ★ there are, the better the quality and the larger the file.
The image file size will also differ according to Recorded Pixels settings.

★★★	Best	This has the lowest compression rate, and is suited for printing large pictures on A4 paper.
★★	Better	This has a standard compression rate, and is suited for viewing as standard photographs or on your computer screen.
★	Good	Highest compression rate. Suited for attaching to e-mail, or for creating websites.

1 Select [Quality Level] on the [ Rec. Mode] menu.

2 Press the four-way controller (◀▶) to change the quality level.

3 Press the OK button.

The camera is ready to take a picture.

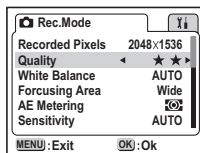

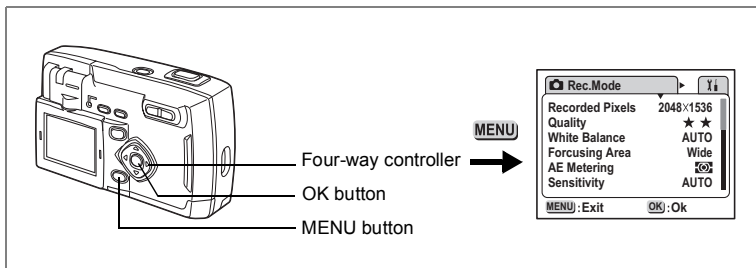











P Picture Mode     

Adjusting the White Balance

Adjusts for natural coloring in your picture, according to the lighting.

	AUTO	Auto	The camera makes the adjustment automatically.
		Daylight	For taking pictures outside in sunlight.
		Shade	For taking pictures outside in the shade.
		Tungsten Light	For taking pictures under standard light bulbs or other tungsten light.
		Fluorescent Light	For taking pictures under fluorescent light.
		Manual	For taking pictures by manually adjusting the white balance.

- 1 Select [White Balance] on the [Rec. Mode] menu.**
- 2 Press the four-way controller (▶).**
The White Balance selection screen is displayed.
- 3 Press the four-way controller (▲▼) to change the setting.**
- 4 Press the OK button twice.**
The camera is ready to take a picture.

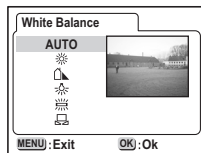

Saving the White Balance  p.72

4

Setting Manually

- 1 Select [Manual] (Manual) on the White Balance selection screen.**
- 2 Point your camera at white paper to fill the screen.**
- 3 Press the OK button.**

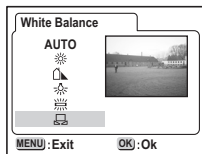

The LCD monitor will display "Adjusting", and return to the menu screen when the white balance is adjusted.

- 4 Press the OK button.**

The camera is ready to take a picture.

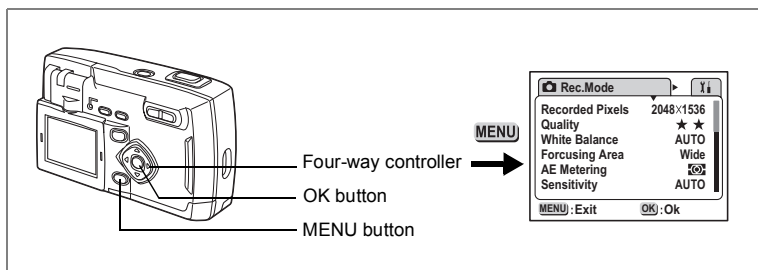

P Picture Mode      

Setting the Focusing Area

You can change the area for autofocus (Focusing Area).

Wide	Normal range
Spot	The autofocus range becomes smaller

- 1** Select **[Focusing Area]** on the **[Rec. Mode]** menu.
- 2** Press the four-way controller (**◀ ▶**) to change the focusing area.
- 3** Press the OK button.

The camera is ready to take a picture.

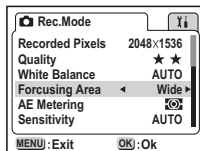

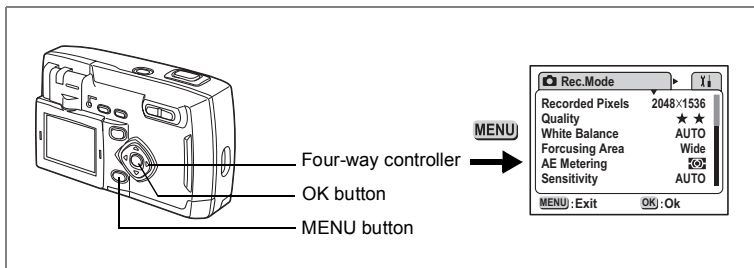

Saving the Focusing Area Setting  p.72



P Picture Mode     

Setting the Light Metering Range

You can choose the part of the screen to use for measuring brightness and determining exposure.

	Multi-segment	Detailed measurement of entire screen to determine exposure.
	Center-weighted	Measures mainly the center of the screen to determine exposure.
	Spot	Measures only the very center of the screen to determine exposure.

- 1 Select [AE Metering] on the [Rec. Mode] menu.**
- 2 Press the four-way controller (◀▶) to change the metering mode.**
- 3 Press the OK button.**

The camera is ready to take a picture.

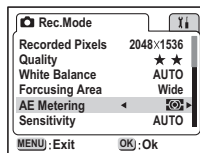

Saving the AE Metering Method  p.72

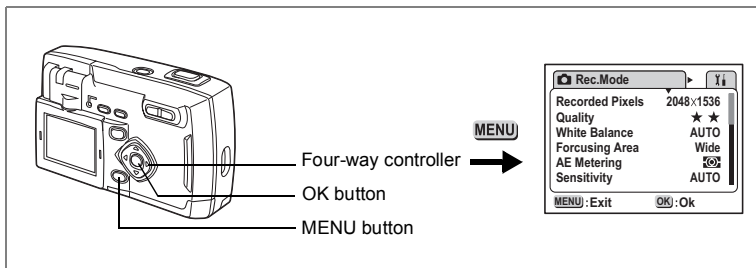

P Picture Mode     

Setting Sensitivity

You can set the Sensitivity to match the brightness of the surroundings.

AUTO	The camera makes the adjustment automatically.
100	<ul style="list-style-type: none"> The lower the Sensitivity (smaller number), the sharper the image with less noise. The shutter speed will be slower in low light conditions. The higher the Sensitivity (larger number), the faster the shutter speed in low light conditions. The image will have more noise.
200	
400	

- 1 Select [Sensitivity] on the [Rec. Mode] menu.**
- 2 Press the four-way controller (◀▶) to change the sensitivity.**
- 3 Press the OK button.**

The camera is ready to take a picture.

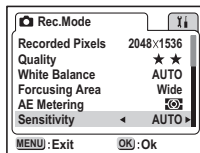

The only available AUTO settings are 100 and 200.

Saving the Sensitivity  p.72

4

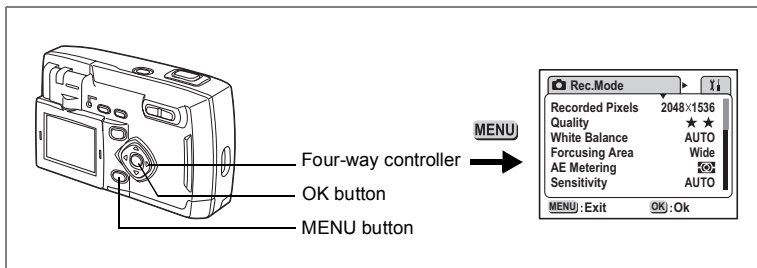

P Picture Mode

Setting the Instant Review Time

You can select the Instant Review display time from 0.5 sec, 1 sec, 2 sec, 3 sec, 5 sec, or OFF (no display).

- 1 Select [Instant Review] on the [Rec. Mode] menu.**
- 2 Press the four-way controller (◀▶) to change the display time.**
- 3 Press the OK button.**

The camera is ready to take a picture.

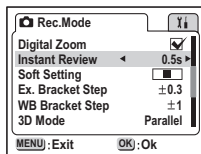

The Instant Review setting stays the same even after the camera is turned off.

P Picture Mode

Setting Image Sharpness

You can make the image outlines sharp or soft.

- 1 Select [Sharpness] on the [Rec. Mode] menu.**
- 2 Press the four-way controller (◀▶) to select [Normal], [Hard], or [Soft].**
- 3 Press the OK button.**

The camera is ready to take a picture.

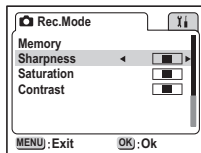

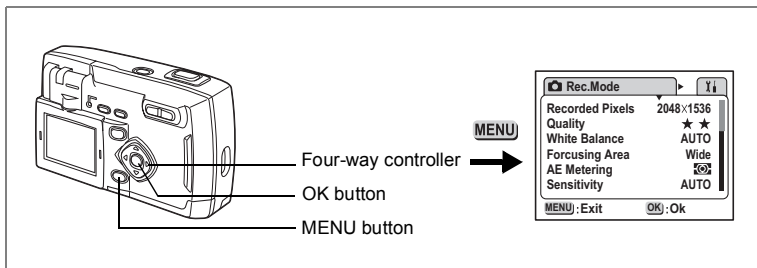

P Picture Mode     

Setting Color Saturation

This sets the color saturation.

- 1** Select [Saturation] on the [**Rec. Mode**] menu.
- 2** Press the four-way controller (◀▶) to select (High), (Normal), or (Low).
- 3** Press the OK button.

The camera is ready to take a picture.

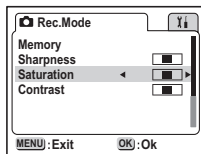

P Picture Mode     

Setting the Image Contrast

You can set the image contrast level.

- 1** Select [Contrast] on the [**Rec. Mode**] menu.
- 2** Press the four-way controller (◀▶) to select (High), (Normal), or (Low).
- 3** Press the OK button.

The camera is ready to take a picture.

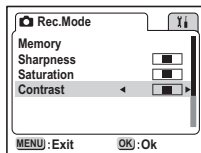

Switching Between Modes

Capture mode is for taking pictures, and Playback mode is for playing back or erasing images.











Switching Between Capture Mode and Playback Mode

- Press the Playback button to switch from Capture mode to Playback mode.
- Press the Playback button or press the shutter release button halfway to switch from Playback mode to Capture mode.

Selecting the Capture Mode

Display the virtual mode dial to select the Capture mode. There are eight Capture modes available.

4

	Program Mode	Lets you set all the functions.	p.49
 (Default Setting)	Picture Mode	You can match the settings to the shooting situation. There are eight picture modes available. (The default setting is  .)	p.50
	Night-Scene Mode	Lets you take dark scenes.	p.53
	Movie Picture Mode	Lets you take movie pictures.	p.54
	Panorama Assist Mode	Lets you take panorama pictures.	p.56
	3D Image Mode	Lets you take 3D pictures.	p.58
	Digital Filter Mode	Lets you set a color filter. (The default setting is B&W.)	p.63
 (Default Setting)	Auto Bracket Mode	Lets you use auto brackets. (The default setting is  .)	p.64

1 Press the four-way controller (▼) in Capture Mode.

The virtual mode dial is displayed.

2 Press the four-way controller (▲▼) to select the desired mode.

The icon will be magnified.

In Digital Filter Mode or Auto Bracket Mode, press the four-way controller (▶) again for detailed settings.

3 Press the OK button.

The icon for the selected Capture mode is displayed. The camera is ready to take the picture.

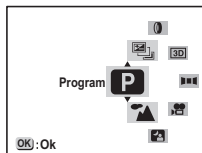

Taking Pictures

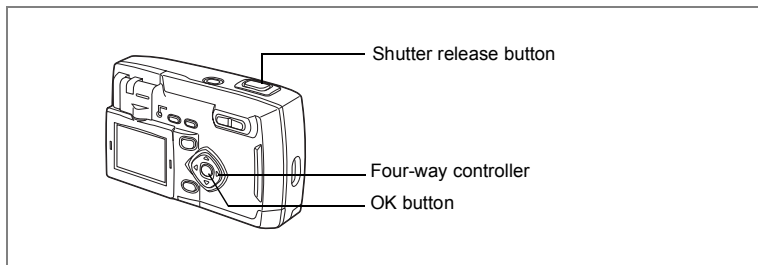

Program Mode

In Program Mode (P), you can set all the functions and take pictures.

1 Press the four-way controller (▼) in Capture Mode.

The virtual mode dial is displayed.

2 Press the four-way controller (▲▼) to select the [Program P].

3 Press the OK button.

The camera is ready to take a picture.

4 Set the functions you want to use.

See “Setting the Capture Functions” (p.36~p.47) for instructions.

5 Press the shutter release button.

The picture will be taken.

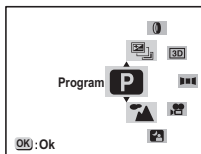

Taking Still Pictures p.22

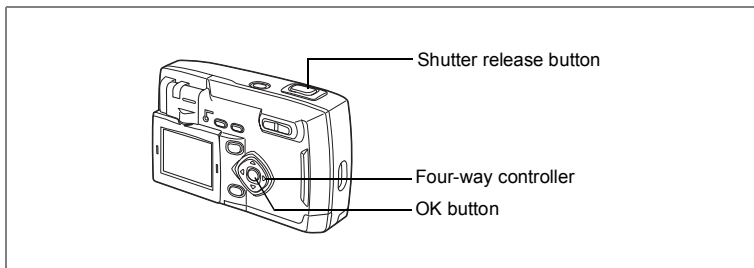

Picture Mode

You can match your settings to the situation.

Picture Mode

There are eight modes available.

	Landscape (Default Setting)	Enhances your landscape photos.
	Flower	Enhances your flower photos.
	Portrait	Enhances your portrait photos.
	Self-Portrait	Enhances self-portraits or pictures including yourself.
SOFT	Soft	Provides a softened effect for your pictures. Softness can be set at seven levels.
	Surf and Snow	Enhances pictures taken against dazzling backgrounds such as beaches or snow.
	Sunset	Beautiful results on pictures of sunsets or sunrises.
	Illustration	Makes the photograph look like a sketch.

1 Press the four-way controller (▼) in Capture Mode.

The virtual mode dial is displayed.

2 Press the four-way controller (▲▼) to select the [Picture Mode (📷)] dial, and press the four-way controller (▶).

The picture mode dial is displayed.

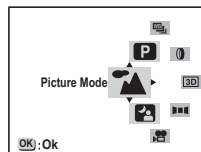

3 Press the four-way controller (▲▼) to select the icon for the desired picture mode.

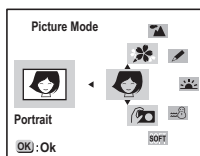

4 Press the OK button.

The Picture mode is selected.

5 Press the shutter release button.

The picture will be taken.



- In Picture mode, your selection is confirmed by pressing the shutter release button half-way or by pressing the four-way controller, or by doing nothing for more than five seconds.
- In Picture mode, the EV compensation, saturation, contrast, sharpness, and white balance are automatically set to the optimum values for each mode. (You can change the settings.)

Setting the Softness

You can set the softness for soft mode in Picture mode.

1 Select [Soft setting] on the [Rec. Mode] menu.

2 Press the four-way controller (◀▶) to set the degree of softness.

Moving the (◻◻) to the right will increase the softening effect. Move it to the left to decrease softness.

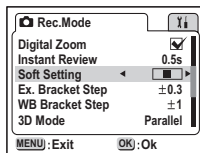

3 Press the OK button.

The camera is ready to take a picture.

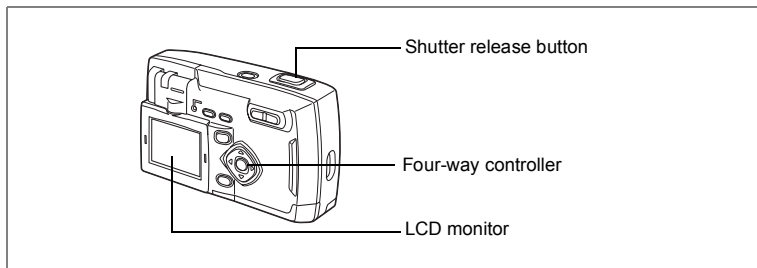

Taking Self-Portraits

You can reverse the LCD monitor while you take a self-portrait or a couple-shot, checking yourself in the LCD monitor while you take the picture.

1 Press the four-way controller (▼) to select [Picture Mode] on the virtual mode dial, and set it to [Self-portrait (Ⓜ)].

2 Rotate the LCD Monitor.

You can see yourself in the LCD monitor. When you rotate the LCD monitor, the image on the monitor rotates (mirror image).

3 Press the shutter release button.

The picture will be taken.



When pressing the shutter release button causes the camera to shake, particularly for taking pictures in low light conditions, secure the camera to a tripod or on another surface and use the self-timer.

Rotating the LCD Monitor ⇨ p.17
 Matching the Picture to the Scene (Picture Mode)
 ⇨ p.50

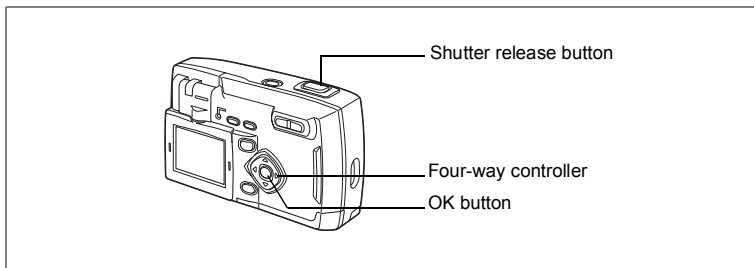

Taking Dark Scenes (Night-Scene Mode)

The settings in this mode are appropriate for taking dark scenes.

1 Press the four-way controller (▼) in Capture Mode.

The virtual mode dial is displayed.

2 Press the four-way controller (▲▼) to select the [Night Scene Mode(☾)].

3 Press the OK button.

The camera is ready to take a picture.

4 Press the shutter release button.

The picture will be taken.

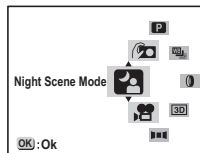

Pressing the Shutter Release Button ⇨ p.23
 Playing Back Still Pictures ⇨ p.24



When taking night-scenes and other pictures with a slow shutter speed, the capture time is nearly doubled, because of a function that removes noise from the image after capture.



Because the shutter speed is slow when taking dark scenes, please stabilize the camera on a tripod or other surface to prevent shaking the camera.

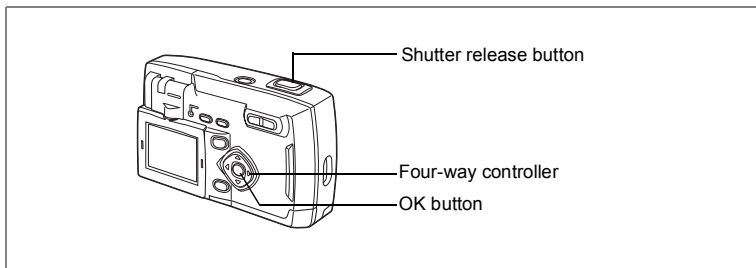

Taking Movie Pictures (Movie Picture Mode)

You can take movie pictures. The maximum length of one recording (1 set) is about 30 seconds. Sound cannot be recorded.

1 Press the four-way controller (▼) in Capture Mode.

The virtual mode dial is displayed.

2 Press the four-way controller (▲▼) to select the [Movie (🎥)].

3 Press the OK button.

- 1 Flash OFF icon
- 2 Movie Picture icon
- 3 Recording time remaining for next set
- 4 Sets remaining

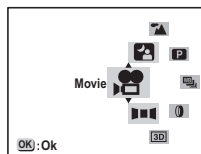

4 Press the shutter release button.

Recording will begin. You can switch the image size using the Zoom button.

- 👆 Subject becomes bigger.
- 👇 Subject becomes smaller.

5 Press the shutter release button.

Playback will end. The remaining available recording time is displayed.

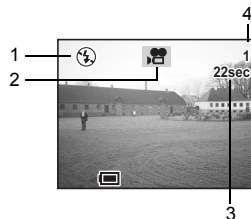

Recording by holding down the shutter release button

If you hold down the shutter release button for one second or more, the camera will record while you hold down the button. Recording stops when you release the shutter release button.

Playing Back Movie Pictures  p.75



- The flash will not fire in Movie Picture mode.
- Continuous shooting is not available in Movie Picture mode.
- The only focus mode available in Movie Picture mode is Autofocus.

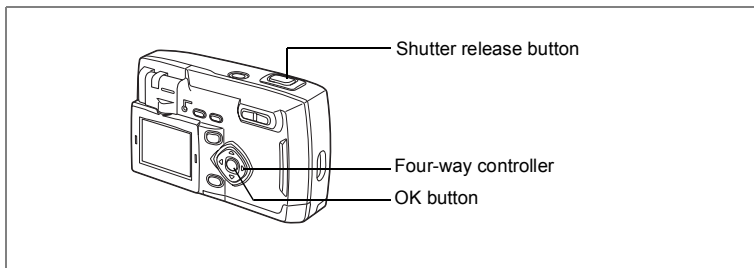

Taking Panorama Pictures (Panorama Assist Mode)

4 ACD photostitcher is only for the English version and the Japanese version.

You can join several images together to form one panorama picture. Use a Windows PC and the provided software to join the images.

1 Press the four-way controller (▼) in Capture Mode.

The virtual mode dial is displayed.

2 Press the four-way controller (▲▼) to select [Panorama Assist (P)].

3 Press the OK button.

4 Press the four-way controller to choose the joining direction.

- ◀ Joins the images at the left.
- ▶ Joins the images at the right.
- ▲ Joins the images at the top.
- ▼ Joins the images at the bottom.

The explanation below will assume that ▶ is selected.



5 Take the first picture.

Press the shutter release button to take the first image. The right edge of the image is displayed in transparent form at the left of the LCD monitor.



6 Move the camera to the right, and take the second picture.

Repeat this procedure for the third and following pictures.

7 Press the OK button.

The screen returns to step 4.



To cancel Panorama Assist mode, switch to any other mode.



- The camera cannot join the images. Use the software provided. For details on joining panorama images, see the separate booklet “Viewing Your Digital Camera Images On Your PC”.
- Continuous shooting is not available in Panorama Assist mode.
- You need a Windows PC for joining panorama pictures. (The provided software is not Macintosh-compatible.)

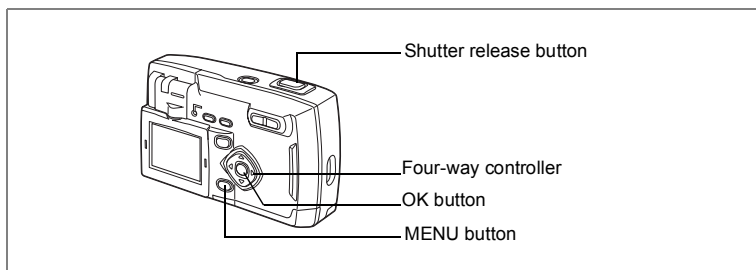

Taking 3D Pictures (3D Image Mode)

Using the LCD monitor, you can take 3D pictures to be viewed by the parallel method or cross method (p.60). Print out the 3D picture and look at it through the 3D image viewer provided. It will appear in three dimensions.

Selecting the viewing method

The default setting is Parallel to view with the 3D Image Viewer. If you do not need to switch to Cross, proceed to step 5.

- 1 Press the MENU button.**
The [Rec. Mode] menu will be displayed.
- 2 Press the four-way controller (▲▼) to select [3D Mode].**
- 3 Press the four-way controller (◀▶) to select Cross.**

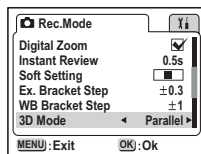

You can also view it without the image viewer.

- 4 Press the OK button.**
The screen returns to the 3D image mode.

Taking Pictures

- 5 Press the four-way controller (▼) in Capture Mode.**
The virtual mode dial is displayed.
- 6 Press the four-way controller (▲▼) to select the 3D Image mode (3D).**

7 Press the OK button.

The screen for taking the first image appears on the left side of the LCD monitor.

8 Take the first image.

Position the subject at the center of the left side of the screen, and press the shutter release button. The image is displayed on the left side of the LCD monitor. The right side of the screen is for taking the second image.



9 Move the camera to the right without changing your stance.

10 Overlap the images.

The first image appears opaque on the right of the screen, overlapping the second. Match the opaque image with the actual image to make the layout match.



11 Press the shutter release button.

The second image is taken, and the display returns to step 7. To take more 3D pictures, repeat the operations from step 8.



- Check the images in Playback mode.
- To cancel 3D Image mode, press the four-way controller (▼) to switch to a different mode.
- Taking pictures of a moving subject will not provide a three-dimensional effect, because two images are required for each subject. If taking a picture of a person, ask your model to stay still, and take the second picture quickly. Shifting the camera horizontally is much easier when using a tripod or other support.
- The camera should be moved about $\frac{1}{40}$ of the distance to the subject. For example, if the distance is 3m, the movement amount would be $3\text{m} \div 40 = 7.5\text{cm}$. Each individual sees 3D images differently, so do not be too concerned. Use the chart below as a guide, and experiment with different movement distances.

Distance to subject	0.1m	0.3m	0.5m	1m	3m	5m
Camera movement	0.5cm	1cm	1.5cm	2.5cm	7.5cm	13cm

Viewing 3D Pictures with the Parallel method and Cross method

Because our eyes are positioned about 6 to 7cm apart, each eye sees at a slightly different angle. The brain processes this difference to produce a three-dimensional image. This principle is applied to taking and viewing 3D pictures.

3D pictures can be viewed by the Parallel method, where the left and right lines of sight are parallel (like looking far away), or by the Cross method, crossing the lines of sight. Viewing a 3D picture without the viewer may take some practice.

Assembling the 3D Image Viewer

Assemble the supplied 3D Image Viewer as shown below.

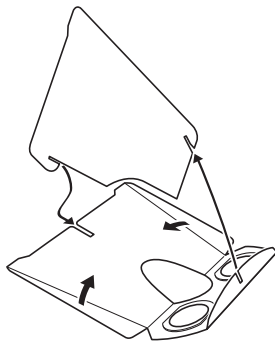

How to view 3D pictures with the 3D Image Viewer

Print out the pictures so they are 11cm to 12cm wide. Place the 3D Image Viewer divider between the two images.

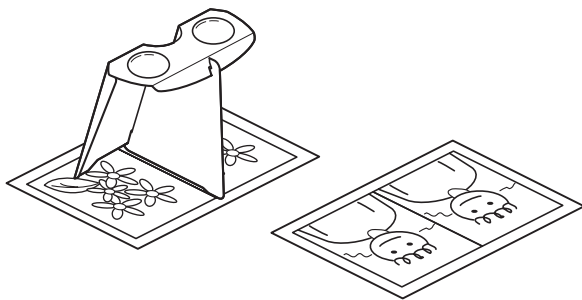

The distance between the eyes differ from person to person. Some may not see a three-dimensional effect even with the same size print. Pictures too large or too small make seeing the three-dimensional effect very difficult. Try different size prints until the right effect is achieved.



- Never look at the sun through the 3D Image Viewer.
- Do not leave the 3D Image Viewer in direct sunlight, as this may cause a fire.

Example of a 3D Picture



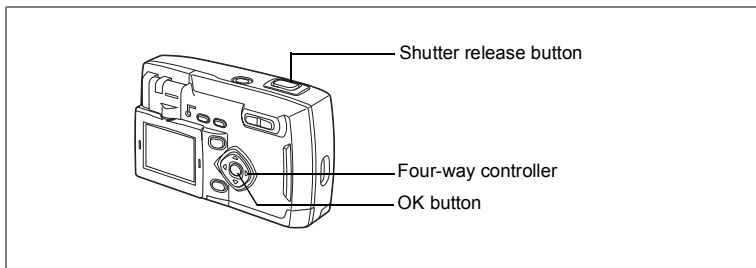

Taking Pictures with Digital Filters (Digital Filter Mode)

You can take pictures with digital filters with a variety of colors, such as red, blue, and green.

Filters

Eight color filters are provided: black-and-white, sepia, red, green, blue, black-and-white+red, black-and-white+green, and black-and-white+blue. When you select a filter in Digital Filter Mode, the display on the LCD monitor is filtered with the selected color, and the pictures are taken in that color.

1 Press the four-way controller (▼) in Capture Mode.

The virtual mode dial is displayed.

2 Press the four-way controller (▲▼) to select the [Digital Filter (0)].

3 Press the four-way controller (▶).

The filter selection screen is displayed.

4 Press the four-way controller (▲▼) to select the filter.

5 Press the OK button.

The camera is ready to take a picture.

6 Press the shutter release button.

The picture is taken.

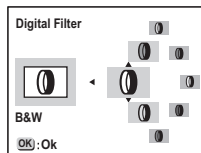
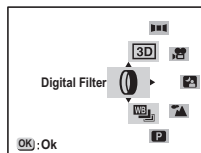

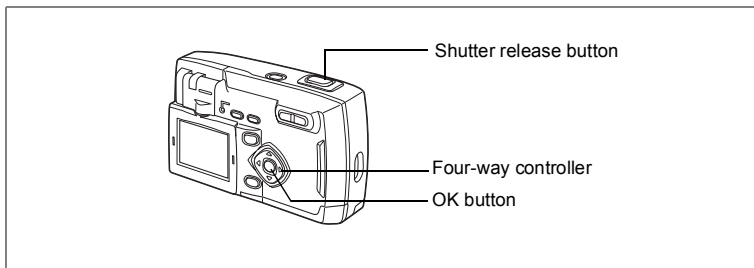

Automatically Change Capture Conditions (Auto Bracket Mode)

You can automatically take three pictures in a row with different settings for exposure, saturation, sharpness, and contrast. For exposure and white balance, the bracket step must be set in advance.

1 Press the four-way controller (▼) in Capture Mode.

The virtual mode dial is displayed.

2 Press the four-way controller (▲▼) to select [Auto Bracket (☰)].

3 Press the four-way controller (▶).

The bracket type selection screen is displayed.

4 Press the four-way controller (▲▼) to select the bracket type.

5 Press the OK button.

The camera is in Bracket Capture Mode.

6 Press the shutter release button.

The pictures are taken in Auto Bracket mode.

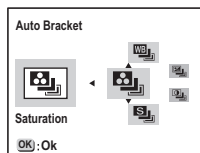

- Check the images in Playback mode.
- Setting the Auto Bracket Mode will cancel the Continuous Shooting mode.
- To exit auto bracket capture mode, switch to another mode.

Playing Back Still Pictures p.24

Setting the Exposure Bracket

You can set the bracket step to use when selecting Ex. Bracketing in Auto Bracket Mode. Select from ± 0.3 , ± 0.7 , ± 1.0 , ± 1.3 , ± 1.7 , or ± 2.0

- 1 Select [Ex. Bracket Step] on the [Rec. Mode] menu.**
- 2 Press the four-way controller (◀▶) to set the step.**
- 3 Press the OK button.**

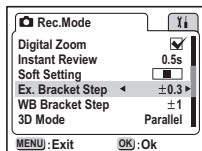

The camera is ready to take a picture.

Three images will be taken; one with standard exposure, one with a positive (+) step, and one with a negative (-) step.

Setting the White Balance Bracket

You can set the bracket step to use when selecting White Balance in Auto Bracket Mode. Select from ± 1 , ± 2 , ± 3 , ± 4 , or ± 5 .

- 1 Select [WB Bracket Step] on the [Rec. Mode] menu.**
- 2 Press the four-way controller (◀▶) to set the step.**
- 3 Press the OK button.**

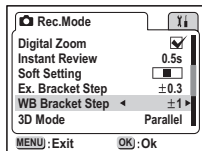

The camera is ready to take a picture.

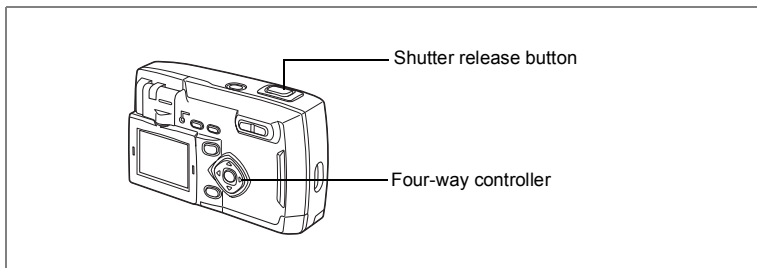

Three images will be taken; one with standard white balance, one with a positive (+) step, and one with a negative (-) step.



P Picture Mode   

Continuous Shooting (Continuous Shooting/ High-Speed Shooting)

Pictures are taken continually while the shutter release button is pressed. There is Continuous Shooting and High-Speed Shooting available.

	Continuous Shooting	Images are captured, processed, and saved one by one.
	High-Speed Shooting	Three frames are taken in a row, followed by image processing and saving.

1 Press the four-way controller (▲) to display  or  on the LCD monitor.

2 Press the shutter release button.

Pictures are taken continually while the shutter release button is pressed.

Recording stops when you release the shutter release button.



Playing Back Still Pictures  p.24



- You can continue shooting until the CF card is full.
- The interval between continuous shots differs according to recorded pixels and quality level settings.



- The flash will not fire in Continuous Shooting mode.
- Continuous shooting and High-speed shooting are not available in 3D Image mode, Movie Picture mode, Panorama Assist mode, or Auto Bracket mode.
- High-speed shooting is not available in night-scene mode, or when using black-and-white+red, black-and-white+green, or black-and-white+blue digital filters.

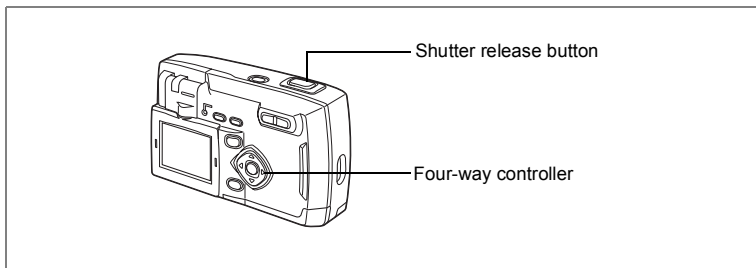

P Picture Mode

Using the Self-Timer

The picture will be taken either 10 seconds or 2 seconds after the shutter release button is pressed.

1 Press the four-way controller (▲) to display or on the LCD monitor.

2 Press the shutter release button.

The self-timer is engaged, and the self-timer lamp lights for about 7 seconds. The picture is taken about 3 seconds after the self-timer lamp begins to blink.

The self-timer is engaged, and the picture is taken about 2 seconds after the self-timer lamp begins to blink.

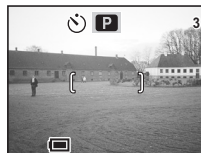

Pressing the four-way controller or the MENU button during count-down display will cancel the self-timer.

Playing Back Still Pictures p.24

Taking a Self-Portraits p.52

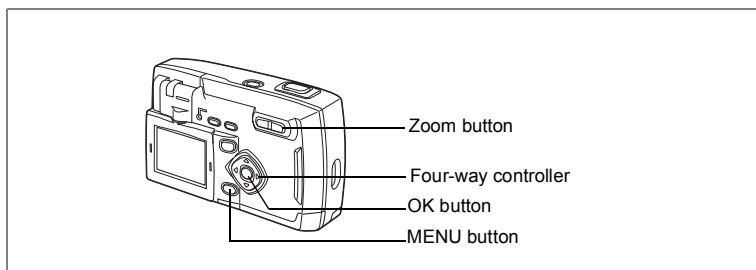

P Picture Mode

Using the Zoom

You can use the Zoom to take pictures in Tele or Wide mode.

1 Press the Zoom button in Capture mode.

- ⬆ Tele: Subject becomes larger.
- ⬆⬆⬆ Wide: Subject becomes smaller.

When the digital zoom function is disabled, there is an optical zoom available up to 3 times. When the digital zoom function is enabled, you can further enlarge the subject up to 8 times.

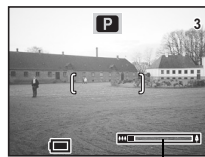

Zoom bar



Digital zoom range

Saving the Zoom Position p.72

Enabling the Digital Zoom Function

1 Press the MENU button in Capture mode.

The [Rec. Mode] menu will be displayed.

2 Press the four-way controller (▼) to select [Digital Zoom].

3 Press the four-way controller (▶) to select (on).

4 Press the OK button.

The camera is ready to take a picture.

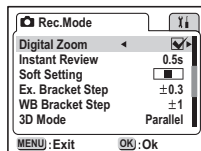

Saving the Digital Zoom Function Setting  p.72

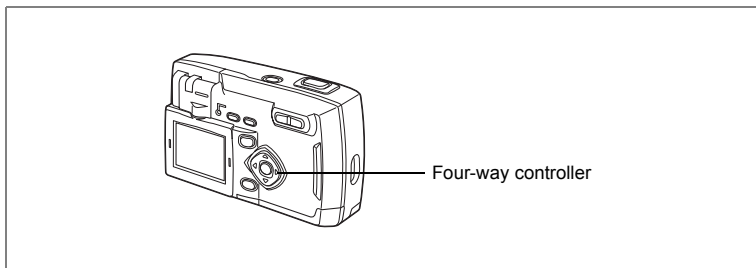

P Picture Mode

EV Compensation

Use EV Compensation when you want to intentionally over expose (brighten) or under expose (darken) your picture.

1 Press the four-way controller (◀▶) in Capture Mode.

- ▶ Adjusts the exposure to over-expose (+ side).
- ◀ Adjusts the exposure to under-expose (- side).



The EV Compensation setting is displayed on the LCD monitor.



When you press the four-way controller (◀▶) once, or when you set this to ± 0 , the display will disappear in two seconds.

Saving the EV Compensation Setting p.72

Saving the Settings

Saving the Menu Items (Memory)

You can choose whether to save the set values when the camera is turned off. If you select On, the camera saves the settings in effect just before the camera is turned off. If you select Off, the settings return to default settings when the camera is turned off.

Item	Description	Default Setting
Flash	Saves the Flash mode setting selected with the button.	<input checked="" type="checkbox"/>
EV compensation	Saves the EV compensation settings.	<input type="checkbox"/>
White Balance	Saves the White Balance settings on the Rec. Mode menu.	<input type="checkbox"/>
Focusing Area	Saves the Focusing Area settings on the Rec. Mode menu.	<input type="checkbox"/>
AE Metering	Saves the AE Metering settings on the Rec. Mode menu.	<input type="checkbox"/>
Sensitivity	Saves the Sensitivity settings on the Rec. Mode menu.	<input type="checkbox"/>
Digital Zoom	Saves the Digital Zoom settings on the Rec. Mode menu.	<input checked="" type="checkbox"/>
Focus Mode	Saves the Focus Mode settings.	<input type="checkbox"/>
Zoom Position	Saves the Zoom Position settings.	<input type="checkbox"/>
Display Mode	Saves the LCD monitor display mode.	<input type="checkbox"/>
File No.	Saves the file numbers. File numbers will continue to have sequential numbers even after changing the CF card.	<input checked="" type="checkbox"/>



- Menu items not included in Memory will also be saved with the settings selected on the menus for each function.
- Zoom positions set within the digital zoom range will not be saved even when Zoom Position is set to On in Memory.

- 1 Press the MENU button in Capture mode.**
- 2 Press the four-way controller (▲▼) to select [Memory].**
- 3 Press the four-way controller (▶).**
The Memory menu is displayed.

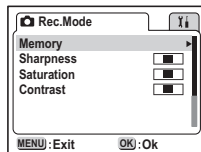

- 4 Press the four-way controller (▲▼) to select the item.**
- 5 Press the four-way controller (◀▶) to select (on) or (off).**
- 6 Press the OK button twice.**

The camera is ready to take a picture.

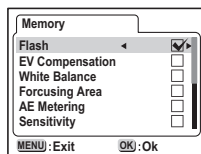

Playing Back Images

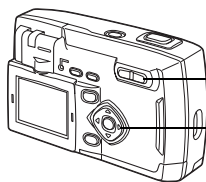

Zoom/Matrix/Quick button

Four-way controller

Playing Back Still Pictures

See “Playing Back Images” (p.24), or “Playing Back Previous or Next Images” (p.24).

5

Zoom Playback

You can play back images magnified up to 12 times. A button operation guide is displayed on the LCD monitor during magnification.

1 In Playback mode, use the four-way controller (◀▶) to select the image to magnify.

2 Press ▲/Q on the Zoom/Matrix/Quick button.

The image is magnified. (1×-12×) Keep pressing to continuously change the magnification.

• **Operations available during Zoom Playback:**

- | | |
|------------------------------|---------------------|
| Four-way controller (▲▼◀▶) | Moves zoom position |
| Zoom/Matrix/Quick button (▲) | Makes image larger |
| Zoom/Matrix/Quick button (▼) | Makes image smaller |

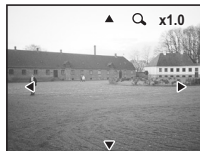

3 Press the shutter release button halfway.

The camera is ready to take a picture.



Zoom Display is not available for movie pictures.

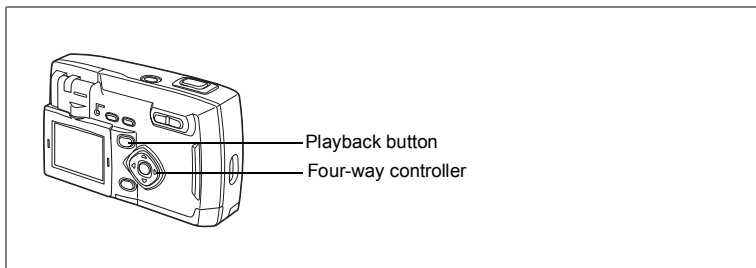

Playing Back Movie Pictures

To play back movie pictures: A button operation guide is displayed on the LCD monitor during playback.

1 In Playback mode, use the four-way controller (◀▶) to select the image to play back.

2 Press the four-way controller (▲).

Playback will start.

• **Operations available during Playback:**

- Four-way controller (◀) Reverse playback
- Four-way controller (▶) Forward playback
- Four-way controller (▲) Pause

• **Operations available while paused:**

- Four-way controller (◀) Frame reverse
- Four-way controller (▶) Frame forward
- Four-way controller (▲) Cancels pause (Playback resumes)

3 Press the four-way controller (▼).

Playback will stop.

4 Press the Playback button.

The camera returns to Capture mode.

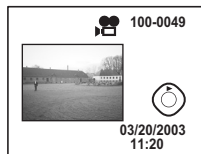

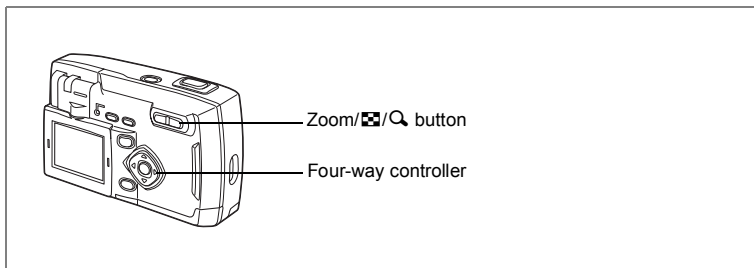

Nine Image Display

You can display nine images at the same time.

1 In Playback mode, use the four-way controller (◀▶) to select the image.

2 Press  on the Zoom  button.

Up to nine small images will be displayed at once.

Press the four-way controller (▲▼◀▶) to select the image. If there are 10 or more images recorded, a scroll bar appears at the right of the screen. With an image selected in the bottom row, pressing the four-way controller (▼) displays the next nine images.

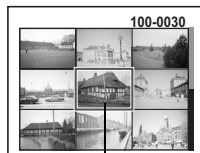

Selected image



With the very last image selected, press the four-way controller (▼) to display the first nine images.

3 Press  on the Zoom  button.

The selected image is displayed by itself.

* For movie pictures, the first frame is displayed.

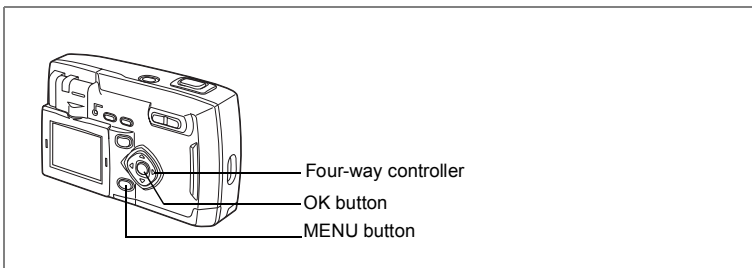

Slideshow

You can play back all recorded images on your CF card successively.

- 1 In Playback mode, use the four-way controller (◀▶) to select the images for the slideshow.**
- 2 Press the MENU button.**
The Playback Mode menu is displayed.
- 3 Press the four-way controller (▼) to select [Slideshow].**
- 4 Press the four-way controller (◀▶) to change the playback interval.**
Select from 3s (3 sec), 5s (5 sec), 10s (10sec), 15s (15 sec), 20s (20 sec), and 30s (30 sec).
- 5 Press the OK button.**
Playback will start at the specified interval.

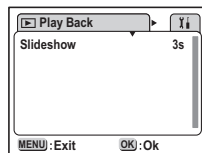

- Pressing the four-way controller or the MENU button during continuous playback will stop the slideshow.
- The slideshow will repeat until you press a button to stop it.
- Movie pictures will be played through to the end and move to the next image, regardless of the playback interval.

Deleting Images

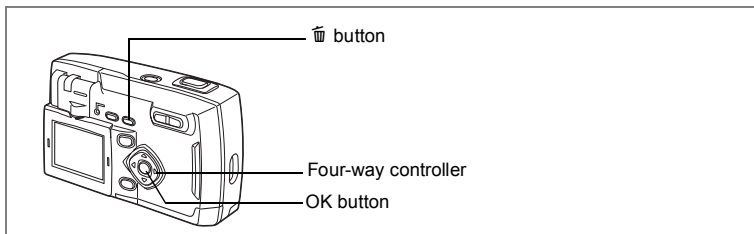

Deleting a Single Image

- 1 In Playback mode, use the four-way controller (◀▶) to select the image to delete.**
- 2 Press the trash button.**
The Delete screen will be displayed.
- 3 Press the four-way controller (▲) to select [Delete].**
- 4 Press the OK button.**

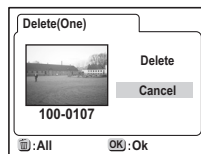

- You can also delete displayed images in Instant Review (p.23).
- You cannot delete protected (Ⓜ) images.

Deleting All Images

You can erase all saved images at once.



- Once deleted, images cannot be restored.
- Protected images cannot be deleted.

- 1 In Playback mode, press the trash button twice.**
The Delete All screen is displayed.
- 2 Select [Delete] with the four-way controller (▲).**
- 3 Press the OK button.**

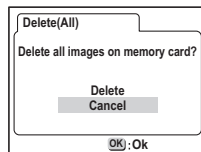

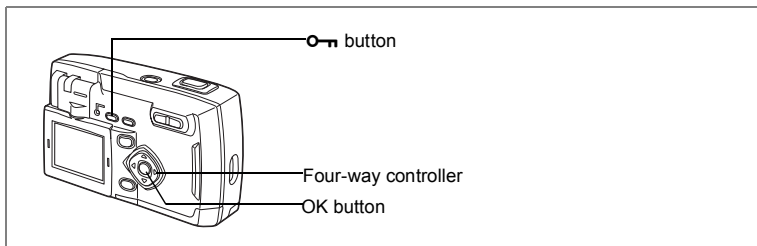

Protecting Images from Deletion (Protect)

You can protect images from being accidentally erased.

- 1 In Playback mode, select the image to protect with the four-way controller (◀▶).**
- 2 Press the On button.**
The Protect screen is displayed.
- 3 Select [Protect] with the four-way controller (▲).**
- 4 Press the OK button.**

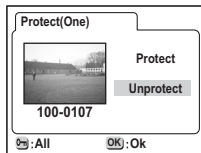

- Select Unprotect in step 3 to cancel the Protect setting.
- The On symbol is displayed when playing back protected images.

Protecting All Images

You can protect all of the images.

- 1 Enter the Playback mode.**
- 2 Press the On button twice.**
The Protect All screen is displayed.
- 3 Select [Protect] with the four-way controller (▲).**
- 4 Press the OK button.**



- Select Unprotect in step 3 to cancel the Protect setting on all of the images.



- Even protected images are deleted by formatting the CF card.

Viewing Images on a TV

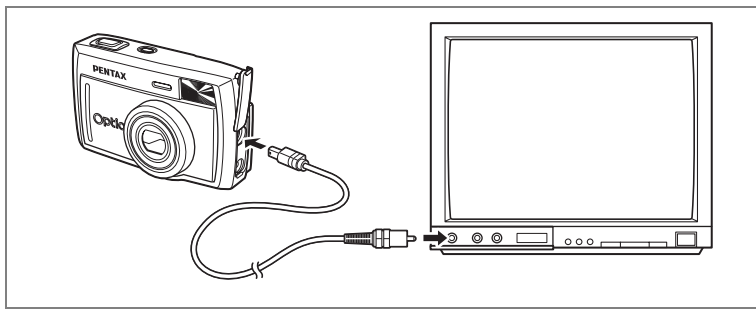

By using the video cable, you can capture and play back images using a TV or other equipment with a video IN jack as your monitor. Make sure that both the TV and the camera are turned off before connecting the cable.

5

Playback/Deleting

- 1** Open the terminal cover and connect the video cable.
- 2** Connect the other end of the video cable to the video IN jack on the TV.
- 3** Turn on the TV and the camera.

Selecting the Video Output Format  p.86



The LCD monitor is always off when the camera is connected to a TV. When using the camera for a long time, use of the AC adapter (optional) is recommended. Please refer to the operating manual of the TV or other connected equipment.

Printing Service Settings (DPOF)

You can print the images on the CF card using a DPOF (Digital Print Order Format) compatible printer, or at a printing service.

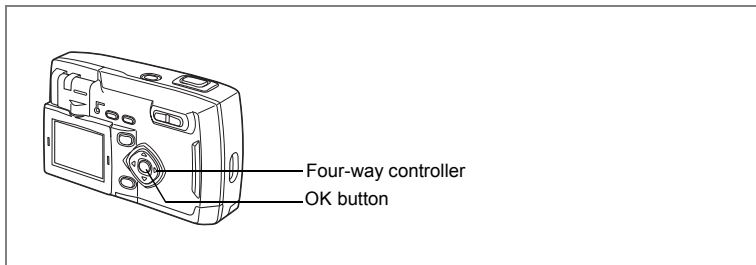

Single Image Settings

Set the following items for each image.

- Copies: Set the number of prints up to 99.
- Date: Specify whether or not to imprint the date on the image.

1 In Playback mode, use the four-way controller (◀▶) to select the image for DPOF settings.

2 Press the four-way controller (▲).

The DPOF screen is displayed.

3 Use the four-way controller (◀▶) to select [ONE], and press the four-way controller (▼).

The frame will move to Number of Prints.

4 Press the four-way controller (◀▶) to select the number of prints, and press the four-way controller (▼).

The frame will move to Date.

5 Press the four-way controller (◀▶) to select or .

- The date will be printed.
- The date will not be printed.

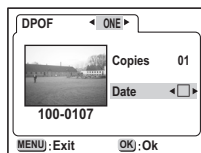
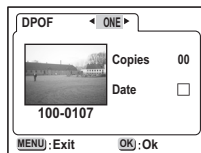

6 Press the OK button.

Prints can be made according to the settings.



- If DPOF settings already exist for an image, the number of prints and the on/off date setting will be displayed.
- To cancel DPOF settings, set the number of prints to 0 and press the OK button.



- DPOF settings are not available for movie pictures.
- Some printers or printing equipment at the photo processing lab may not imprint the date even when the DPOF setting is set.

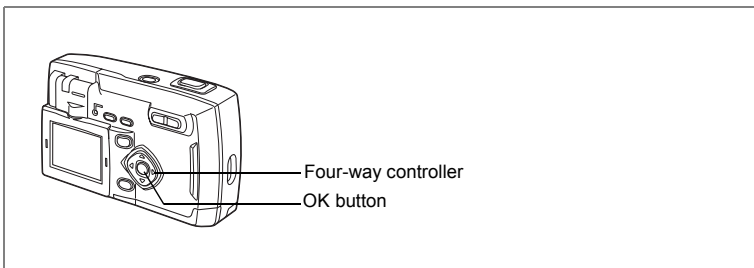

Settings for All Images

- 1 Press the four-way controller (▲) in Playback Mode.**
The DPOF screen is displayed.
- 2 Press the four-way controller (◀▶) to select [All] and press the four-way controller (▼).**
The frame will move to Number of Copies.
- 3 Press the four-way controller (◀▶) to set the number of prints.**
The maximum setting is 99.
- 4 Press the four-way controller (▼).**
- 5 Press the four-way controller (◀▶) to select or for the date.**
 - The date will be printed.
 - The date will not be printed.
- 6 Press the OK button.**
Prints can be made according to the settings.

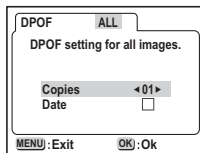

- Settings for all images will cancel settings for single images.
- When you specify the number of prints for all images, the number of prints applies to all images. Before printing, always check that the number is correct.
- DPOF settings are not available for movie pictures.
- To cancel DPOF settings, with "All Images" selected, set the number of prints to 00.

Camera Settings

How to recall the [Y] Set-up menu

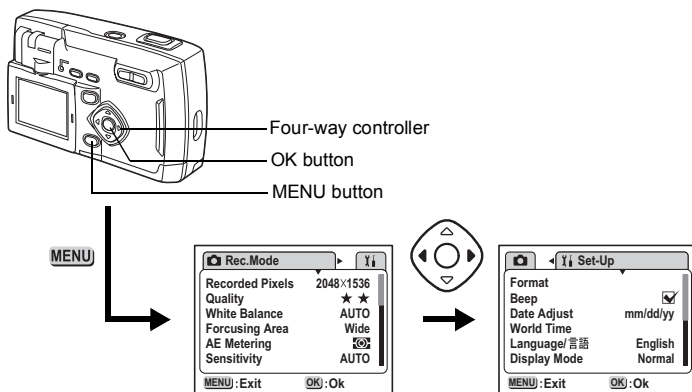

6 Formatting a CF card

Formatting will delete all the data on the CF card.



- Do not open the CF card cover while formatting a CF card. The card may be damaged beyond use.
- Please note that formatting will delete protected images as well.

- 1 Select [Format] on the [Y] Set-up] menu.**
- 2 Press the four-way controller (▶).**
The format screen is displayed.
- 3 Select [Format] with the four-way controller (▲).**
- 4 Press the OK button.**

Formatting begins. When formatting is complete, the camera is ready to take a picture.

Changing the Date Style and Date/Time

You can change the initial date and time settings. You can also set the date display style. Choose from y/m/d, m/d/y, and d/m/y.

- 1 Select [Date Adjust] on the [ⓧi Set-up] menu.**
- 2 Press the four-way controller (▶).**

The Date Adjust screen is displayed.

See “Initial Settings” (p.18) for instructions on setting the date and time.

Changing the Display Language

You can change the language of the menus and error messages.

- 1 Select [Language] on the [ⓧi Set-up] menu.**
- 2 Press the four-way controller (▶).**
The Language setting screen is displayed.
- 3 Select your language with the four-way controller (▲▼).**
- 4 Press the OK button.**
Menus are displayed in the language of your choice.
- 5 Press the OK button.**

The camera is ready for capture or playback.

How to recall the [Y] Set-up] menu

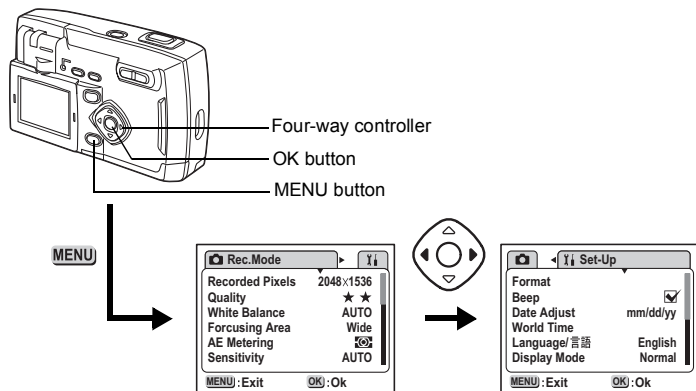

Selecting the Video Output Format

You can select the output format (NTSC or PAL) for capturing or playing back images on a TV monitor.

- 1 Select [Video Out] on the [Y] Set-up] menu.
- 2 Press the four-way controller (◀▶) to select NTSC or PAL, to match your TV output format.
- 3 Press the OK button.

The camera is ready for capture or playback.

Turning the Operation Sound On and Off

You can turn the operation sounds on and off.

- 1 Select [Beep] on the [Y] Set-up] menu.
- 2 Press the four-way controller (◀▶) to select (on) or (off).
- 3 Press the OK button.

The camera is ready for capture or playback.

Setting World Time

The date and time set in “Initial Settings” (p.18) are the Home Time (your usual time zone) setting.

Setting World Time enables you to display the local date and time on the monitor when traveling overseas.

1 Select [World Time] on the [Yi Set-up] menu.

2 Press the four-way controller (▶).

The World time setting screen is displayed.

3 Press the four-way controller (◀▶) to switch between and .

Displays the time in the country selected in World time.

Displays the time in the country selected as Home Time.

4 Press the four-way controller (▼).

This sets world time city.

If New York is selected as the world time city, New York's position blinks on the world map, and the ✈ will display the code for New York (NYC) and the local time.

5 Press the four-way controller (◀▶) to select the World Time city, and press the four-way controller (▼).

6 Press the four-way controller (◀▶) to select DST (on) or (off), and press the four-way controller (▼).

This sets home time city.

If New York is selected for home time city, press the four-way controller (◀▶) to select your Home time city, or turn DST on and off.

7 Press the OK button 2 times.

The camera is ready to capture or play back images with the correct date and time.

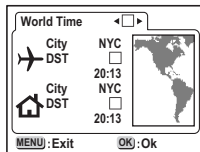

See the list on p.92 for available cities and their codes.

How to recall the [i] Set-up] menu

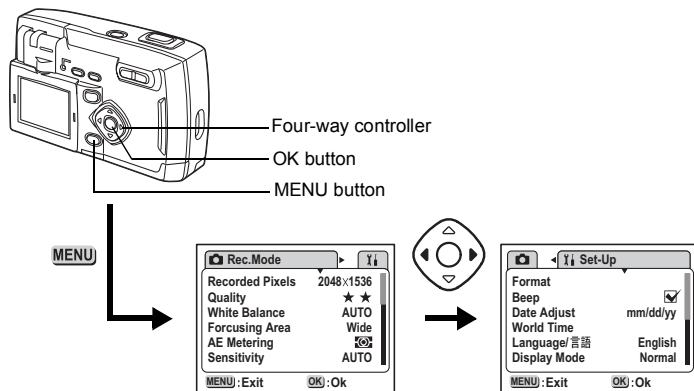

Setting the Display Mode

This determines the content displayed on the LCD monitor. You can choose Normal, Histogram, Grid, or No Information. Capture mode and Playback mode display different information on the screen.

Normal

Capture information is displayed.

- 1 Flash
- 2 Focus Mode
- 3 Capture method
- 4 Capture mode
- 5 Autofocus frame
- 6 Capacity remaining
- 7 Battery symbol
- 8 Date and Time
- 9 Shutter speed · Aperture value
- 10 Folder name · File name

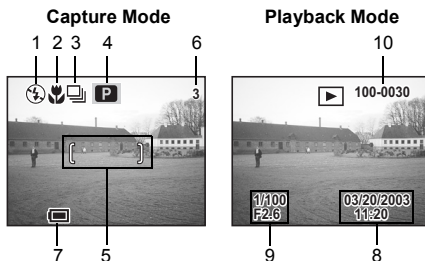

Histogram

Brightness distribution is displayed. The horizontal axis shows brightness (dark to bright left to right), and the vertical axis shows the pixels.

Capture Mode

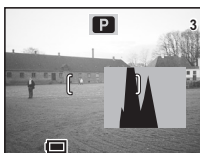

Playback Mode



Grid

The grid is not displayed in Playback mode.

Capture Mode

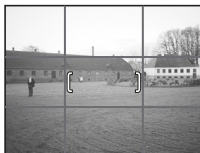

Capture Mode



No Information

Capture information is not displayed.

- During Autofocus, the Autofocus frame and battery icon are displayed.
- Settings are displayed for several seconds when changed.

- 1 Select [Display Mode] on the [Yi Set-up] menu.**
- 2 Press the four-way controller (◀▶) to select your desired display mode.**
- 3 Press the OK button.**

The camera is ready for capture or playback.

How to recall the [Yi Set-up] menu

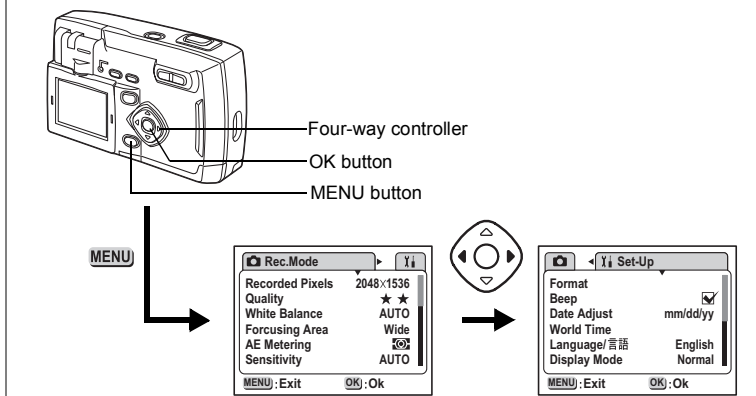

Screen Effect

You can use various animated effects when switching display screens on the LCD monitor.

- 1 Select [Screen Effect] on the [Yi Set-up] menu.**
- 2 Press the four-way controller (◀▶) to select (on) or (off).**
- 3 Press the OK button.**
The camera is ready for capture or playback.

Setting the Background Color

This sets the background design and color displayed on the LCD monitor.

- 1 Select [Background Color] on the [Yi Set-up] menu.**
- 2 Press the four-way controller (▶).**
The Background color screen is displayed.
- 3 Press the four-way controller (◀▶▶▼) to select the background color.**
- 4 Press the OK button twice.**
The camera is ready for capture or playback.

Setting Auto Power Off

You can set the camera to turn off automatically after a certain length of inactivity.

- 1 Select [Auto Power Off] on the [Yi Set-up] menu.**
- 2 Press the four-way controller (◀▶) to select 3 min, 5 min, or OFF.**
- 3 Press the OK button.**

The camera is ready for capture or playback.



Auto Power Off will not work during slideshow playback or a USB connection.

Setting LCD Monitor Brightness

You can set the brightness for your LCD monitor.

- 1 Select [Brightness Level] on the [Yi Set-up] menu.**
- 2 Press the four-way controller (◀▶) to adjust the brightness while you watch the LCD monitor.**

Press the four-way controller (◀) to darken the display, and the four-way controller (▶) to brighten it.

- 3 Press the OK button twice.**

The camera is ready for capture or playback.

Resetting to Default Settings [Reset]

This resets all settings other than Date/Time, Language, Video Out, Date Style, and World Time.

- 1 Select [Reset] on the [Yi Set-up] menu.**
 - 2 Press the four-way controller (▶).**
- The Reset screen is displayed.
- 3 Press the four-way controller (▲) to select [Reset].**
 - 4 Press the OK button.**

The camera is ready for capture or playback.

Appendix

List of City Names

There are the cities and code numbers available for setting the world time.

PPG	Pagopago	THR	Tehran
HNL	Honolulu	DXB	Dubai
ANC	Anchorage	KHI	Karachi
YVR	Vancouver	KBL	Kabul
SFO	San Francisco	MLE	Male
LAX	Los Angeles	DEL	Delhi
YYC	Calgary	CMB	Colombo
DEN	Denver	KTM	Kathmandu
MEX	Mexico City	DAC	Dacca
CHI	Chicago	RGN	Rangoon
MIA	Miami	BKK	Bangkok
YTO	Toronto	KUL	Kuala Lumpur
NYC	New York	VTE	Vientiane
SCL	Santiago	SIN	Singapore
CCS	Caracas	PNH	Phnom Penh
YHZ	Halifax	SGN	Ho chi Minh
BUE	Buenos Aires	JKT	Jakarta
SAO	Sao Paulo	HKG	Hong Kong
RIO	Rio de Janeiro	PER	Perth
MAD	Madrid	BJS	Beijing
LON	London	SHA	Shanghai
PAR	Paris	MNL	Manila
MIL	Milano	TPE	Taipei
ROM	Rome	SEL	Seoul
BER	Berlin	ADL	Adelaide
JNB	Johannesburg	TYO	Tokyo
IST	Istanbul	GUM	Guam
CAI	Cairo	SYD	Sydney
JRS	Jerusalem	NOU	Noumea
MOW	Moscow	WLG	Wellington
JED	Jeddah	AKL	Auckland







Messages

The following messages may be displayed on the LCD monitor during camera operation.

Memory full	The CF card memory is full, and no more images can be saved. Insert a new CF card or delete unwanted images. (p.15, p.78) You may be able to save the image by changing the quality level or recorded pixels. (p.39, p.40)
No image	There are no images for playback on the CF card.
Camera cannot display this image	You are trying to play back an image not supported by this camera. You may be able to display this on a PC or another brand of camera.
No card in camera	The CF card is not inserted in the camera. (p.15)
Battery depleted	The battery is exhausted. Charge the battery if it is an rechargeable battery. Otherwise, replace with new batteries. (p.12)
Memory card error	The CF card has a problem, and image capture and playback are impossible. Try displaying it on a PC.
Card not formatted	The CF card inserted is not formatted, or has been formatted on a PC or other device. (p.84)
Data being recorded	The image is being recorded onto the CF card.
Changing the settings	The image protect settings or DPOF settings are being changed.
Formatting	The CF card is being formatted.
Deleting	The image is being deleted.
Image folder could not be created	The maximum file number has been used, and no more images can be saved. Insert a new CF card or format the CF card. (p.84)
Settings not stored	The CF card memory is full, and no more DPOF settings can be made.
Could not save image	The image could not be saved because of a CF card error.

Troubleshooting

Problem	Cause	Remedy
The camera will not turn on.	No batteries are installed	Check whether battery is installed. If not, install battery.
	CF card cover is open	Close the CF card cover.
	Battery is installed incorrectly	Check orientation of battery. Reinsert battery according to the (-) and (+) symbols in the battery compartment. (p.12)
	Battery is exhausted	Install new batteries in the camera. Or, use the AC Adapter.
No image on the LCD monitor	Connected to a TV	The LCD monitor is always off when the camera is connected to a TV. (The LCD monitor is also off when the video cable I-VC2 is connected to the camera.)
	Image is displayed but hard to see	Images on the LCD monitor may be hard to see when taking pictures outside in sunlight. Change the brightness settings on your LCD monitor. (p.91) Or, use the LCD monitor hood.(p.17)
Shutter release button will not work	Flash is charging	While the flash status lamp is flashing red, the flash is being charged and a picture cannot be taken. The lamp lights red when charging is complete.
	The CF card is full	Insert a CF card with some space, or delete unwanted images. (p.15, p.78)
	Recording	Please wait until recording is finished.

Problem	Cause	Remedy
Out of focus	Subject is difficult for Autofocus to handle	Subjects difficult for Autofocus include those with low contrast (blue skies, white walls), dark objects, fine-patterned objects, fast-moving objects, and landscapes seen through a window or net. Focus on something at the same distance as your subject, secure the focus (by pressing shutter release button halfway), aim at your subject, and press shutter release button fully.
	Subject is not in Focusing Area	Position focusing target within the frame (Focusing Area) at the center of the LCD screen. If your subject is not within the Focusing area, first focus on your subject within the AF area, secure the focus (by pressing shutter release button halfway), then reframe your picture as desired, and press shutter release button fully.
	Subject is too close	Set the focus mode on  . (p.36)
	The focus mode is on 	When the focusing mode is on  , normal pictures will be out of focus.
Picture is dark	Subject is too far away in a dark environment (night-scenes, etc.)	If the subject is too far away, the image will be dark. Take the picture within the flash range.
	Background is dark	When taking a picture of a person against a dark background, the person may appear clearly while the background appears dark, because the flash does not reach it. If you select the  mode on the virtual dial screen, both the person and the night-scene will be clear. (p.53)
Flash does not fire	The Flash Mode is set to Off	Set to Auto or  . (p.38)
	The Capture mode is set on  , Continuous Capture, or  .	The flash will not fire in these modes.

Optional Accessories

The following optional accessories are available for this camera.

AC Adapter D-AC5

USB Cable I-USB2 (included)

Video cable I-VC2 (included)

Camera Case O-CC5

Strap O-ST5 (included)

3D Image Viewer O-3DV1

Main Specifications

Model	Fully automatic compact-type digital still camera with built-in zoom	
Effective Pixels	3.2 megapixels	
Sensor	3.34 megapixels (total pixels), 1/2.7 inch interline transfer CCD with a primary color filter	
Recorded Pixels	Still	2048×1536 pixels, 1600×1200 pixels, 1024×768 pixels, 640×480 pixels
	Movie picture	320×240 pixels
Sensitivity	Auto, Manual (Equivalent to ISO100, ISO200, and ISO400)	
File Format	Still	JPEG (Exif2.2), DCF, DPOF, PRINT Image Matching II
	Movie picture	AVI (Open DML Motion JPEG), about 15fps
Quality Level	"Best", "Better", "Good"	
Storage Medium	Compact Flash (CF) Type I	

Image Storage Capacity

Quality Level Recorded Pixels	Best	Better	Good	Movie picture (320×240)
2048×1536	8	16	33	30 sec × 2 sets
1600×1200	13	27	60	
1024×768	24	50	89	
640×480	50	89	128	

- These figures show the number of shots when using a 16MB CF card.

White Balance	Auto, Daylight, Shade, Tungsten Light, Fluorescent light, Manual	
Lens	Focal Length	5.8mm - 17.4mm (Equivalent to 38 - 114mm in 35mm format)
	Aperture	f/2.6 - f/5.0
	Lens Composition	6 elements in 5 groups (one lens aspherical on both sides)
	Zoom type	Electrically driven
	Capture Range	38.4mm×28.5mm (full screen) (Using macro mode or manual focus at max. WIDE position)
	Lens Barrier	Electrically driven
Digital Zoom	Capture Mode	Max 2.7× (Combines with 3× optical zoom to provide zoom equivalent to 8× max.)
LCD monitor	1.5 TFT color LCD monitor (with backlight and brightness control) 180-degree rotation mechanism included	
Playback Functions	Single-frame, 9-frame index, enlargement (max. 12×), scroll, slideshow, movie playback	
Autofocus system	Type	TTL contrast detection by sensor
	Capture Range (From lens front)	Normal: 0.4m ~ ∞ (full zoom range) Macro: 0.1m ~ 0.5m (full zoom range) Infinity-landscape: ∞ (full zoom range)
	Focus Lock	By pressing the shutter release button halfway

Manual Focus	0.1m ~ ∞	
Exposure Mechanism	AE Metering	TTL metering by sensor (multi-segment, center-weighted, spot)
	Exposure modes	Standard, PICT, Night-scene, Movie, 3D
	EV compensation	±2EV (Can be set in 1/3EV steps)
	Movie Picture	Recording time approx. 1 sec - 30 sec.
	Auto Bracket available	
Shutter	Model	Electronic/Mechanical shutter
	Speed	Approx. 1/1500 sec - 4 sec.
Flash	Model	Automatic flash with red-eye reduction function
	Flash Modes	Auto, Flash Off, Flash On, Auto+Red-eye reduction, Flash On+Red-eye reduction
	Capture Range	Wide Approx. 0.2m-5.0m w/Sensitivity AUTO Tele Approx. 0.1m-2.7m w/Sensitivity AUTO
Drive Modes	Single-frame, Continuous, Self-timer	
Self-timer	Electronic control, operation time: approx. 10 sec.	
Time function	World Time settings for 62 cities (28 time zones)	
Power Supply	Lithium battery CR-V3, two AA batteries (Alkaline, nickel, Ni-MH, Lithium), AC Adapter Kit (optional)	
Battery Life	Approx. 650 images	(with 50% of shooting using flash, and using lithium battery CR-V3) * Based on PENTAX measuring conditions.
I/O Port	USB/AV terminal (PC communication USB1.1), external power supply terminal	
Video Output format	NTSC/PAL	
Size	105 (W) × 63 (H) × 41.5 (D) mm (excludes operating members)	
Mass	180g (excludes battery and CF card)	
Mass when shooting	230g (Includes battery and CF card)	
Accessories	Lithium battery CR-V3, 3D image viewer, USB cable, software (CD-ROM), video cable, strap, LCD monitor hood, operating manual	

WARRANTY POLICY

All PENTAX cameras purchased through authorized bona fide photographic distribution channels are guaranteed against defects of material or workmanship for a period of twelve months from date of purchase. Service will be rendered, and defective parts will be replaced without cost to you within that period, provided the equipment does not show evidence of impact, sand or liquid damage, mishandling, tampering, battery or chemical corrosion, operation contrary to operating instructions, or modification by an unauthorized repair shop. The manufacturer or its authorized representatives shall not be liable for any repair or alterations except those made with its written consent and shall not be liable for damages from delay or loss of use or from other indirect or consequential damages of any kind, whether caused by defective material or workmanship or otherwise; and it is expressly agreed that the liability of the manufacturer or its representatives under all guarantees or warranties, whether expressed or implied, is strictly limited to the replacement of parts as hereinbefore provided. No refunds will be made on repairs by nonauthorized PENTAX service facilities.

Procedure During 12-month Warranty Period

Any PENTAX which proves defective during the 12-month warranty period should be returned to the dealer from whom you purchased the equipment or to the manufacturer. If there are no representatives of the manufacturer in your country, send the equipment to the manufacturer, with postage prepaid. In this case, it will take a considerable length of time before the equipment can be returned to you owing to the complicated customs procedures required. If the equipment is covered by warranty, repairs will be made and parts replaced free of charge, and the equipment will be returned to you upon completion of servicing. If the equipment is not covered by warranty, regular charges of the manufacturer or of its representatives will apply. Shipping charges are to be borne by the owner. If your PENTAX was purchased outside of the country where you wish to have it serviced during the warranty period, regular handling and servicing fees may be charged by the manufacturer's representatives in that country. Notwithstanding this, your PENTAX returned to the manufacturer will be serviced free of charge according to this procedure and warranty policy. In any case, however, shipping charges and customs clearance fees to be borne by the sender. To prove the date of your purchase when required, please keep the receipt or bills covering the purchase of your equipment for at least a year. Before sending your equipment for servicing, please make sure that you are sending it to the manufacturer's authorized representatives or their approved repair shops, unless you are sending it directly to the manufacturer. Always obtain a quotation for the service charge, and only after you accept the quoted service charge, instruct the service station to proceed with the servicing.

- This warranty policy does not affect the customer's statutory rights.
- The local warranty policies available from PENTAX distributors in some countries can supersede this warranty policy. Therefore, we recommend that you review the warranty card supplied with your product at the time of purchase, or contact the PENTAX distributor in your country for more information and to receive a copy of the warranty policy.



The CE Mark is a Directive conformity mark of the European Community.

For customers in USA

STATEMENT OF FCC COMPLIANCE

This device complies with Part 15 of the FCC Rules. Operation is subject to the following two conditions: (1) This device may not cause harmful interference, and (2) this device must accept any interference received, including interference that may cause undesired operation. Changes or modifications not approved by the party responsible for compliance could void the user's authority to operate the equipment. This equipment has been tested and found to comply with the limits for a Class B digital device, pursuant to part 15 of the FCC Rules.

These limits are designed to provide reasonable protection against harmful interference in a residential installation. This equipment generates, uses and can radiate frequency energy and, if not installed and used in accordance with the instructions, may cause harmful interference to radio communications. However, there is no guarantee that interference will not occur in a particular installation.

If this equipment does cause harmful interference to radio or television reception, which can be determined by turning the equipment off and on, the user is encouraged to try to correct the interference by one or more of the following measures:

- Reorient or relocate the receiving antenna.
 - Increase the separation between the equipment and receiver.
 - Connect the equipment into an outlet on a circuit different from that to which the receiver is connected.
- * Consult the dealer or an experienced radio/TV technician for help.

For customers in Canada

This Class B digital apparatus meets all requirements of the Canadian Interference - Causing Equipment Regulations.

Pour les utilisateurs au Canada

Cet appareil numérique de la classe B respecte toutes les exigences du Règlement sur le matériel brouilleur du Canada.

The CE Mark is a Directive conformity mark of the European Community.

Declaration of Conformity

According to 47CFR, Parts 2 and 15 for
Class B Personal Computers and Peripherals

We: PENTAX U.S.A., Inc.

Located at: 35 Inverness Drive East
Englewood, Colorado 80112 USA
Phone: 303-799-8000 FAX: 303-790-1131

Declare under sole responsibility that the product identified herein, complies with 47CFR Parts 2 and 15 of the FCC rules as a Class B digital device. Each product marketed, is identical to the representative unit tested and found to be compliant with the standards. Records maintained continue to reflect the equipment being produced can be expected to be within the variation accepted, due to quantity production and testing on the statistical basis as required by 47CFR §2.909. Operation is subject to the following two conditions: (1) This device may not cause harmful interference, and (2) This device must accept any interference received, including interference that may cause undesired operation. The above named party is responsible for ensuring that the equipment complies with the standards of 47CFR §15.101 to §15.109.

Product Name: PENTAX Digital Still Camera

Model Number: Optio 33L

Contact person: Customer Service Manager

Date and Place: February, 2003, Colorado

Memo

- PENTAX Corporation** 2-36-9, Maeno-cho, Itabashi-ku, Tokyo 174-8639,
JAPAN
(<http://www.pentax.co.jp/>)
- PENTAX Europe GmbH (European Headquarters)**
Julius-Vosseler-Strasse, 104, 22527 Hamburg,
GERMANY
(HQ - <http://www.pentaxeurope.com>)
(Germany - <http://www.pentax.de>)
- PENTAX U.K. Limited** PENTAX House, Heron Drive, Langley, Slough, Berks
SL3 8PN, U.K.
(<http://www.pentax.co.uk>)
- PENTAX France S.A.S.** 12/14, rue Jean Poulmarch, 95106 Argenteuil Cedex,
FRANCE
- PENTAX Benelux B.V.** (for Netherlands)
Spinveld 25, 4815 HR Breda, NETHERLANDS
(<http://www.pentax.nl>)
(for Belgium & Luxembourg)
Weiveldlaan 3-5, 1930 Zaventem, BELGIUM
(<http://www.pentax.be>)
- PENTAX (Schweiz) AG** Widenholzstrasse 1 Postfach 367 8305 Dietlikon,
SWITZERLAND (<http://www.pentax.ch>)
- PENTAX Scandinavia AB** P.O. Box 650, 75127 Uppsala, SWEDEN
(<http://www.pentax.se>)
- PENTAX U.S.A., Inc** 35 Inverness Drive East, Englewood, Colorado 80112,
U.S.A.
(<http://www.pentax.com>)
- PENTAX Canada Inc.** 3131 Universal Drive, Mississauga, Ontario L4X 2E5,
CANADA
(<http://www.pentaxcanada.ca>)

<http://www.digital.pentax.co.jp>



- Printed on recycled paper
- Specifications and external dimensions are subject to change without notice.

57255

Copyright © PENTAX Corporation 2003
01-200305 Printed in Japan

Free Manuals Download Website

<http://myh66.com>

<http://usermanuals.us>

<http://www.somanuals.com>

<http://www.4manuals.cc>

<http://www.manual-lib.com>

<http://www.404manual.com>

<http://www.luxmanual.com>

<http://aubethermostatmanual.com>

Golf course search by state

<http://golfingnear.com>

Email search by domain

<http://emailbydomain.com>

Auto manuals search

<http://auto.somanuals.com>

TV manuals search

<http://tv.somanuals.com>