



Specifications: RS800i

Mounting hardware included

System Type	8" Coax, open-ceiling, ported (64 Watt transformer for 25/70.7/100 Volt or voice coil/8 Ohm direct)
Frequency Response (-3 dB) ¹	65 Hz - 22 kHz
Low Frequency (-10 dB) ¹	48 Hz - 22 kHz
Max. Program Power	250 Watts
Max. Continuous Power RMS ²	125 Watts
Max. SPL dB @ 1 M RMS	112.0 dB
Sensitivity dB @ 1W/1M ³	92.5 dB
Impedance (nominal)	8 Ohm (nominal value)
Coverage Angle (-6 dB @ 2 kHz)	100°
Coverage Angle (-6 dB @ 10 kHz)	135°
Directivity Factor (Q)	4.26 (Averaged 100 Hz - 10 kHz); 7.10 @ 2 kHz
Directivity Index (DI)	5.29 dB (Averaged 100 Hz - 10 kHz); 8.51 dB @ 2 kHz
Tap Selector	6-Position rotary switch with voice coil/8 Ohm direct

Transformer Taps

70.7 V	Output	100 V	Output	25 V	Output
64 W	110.5 dB	64 W	110.5 dB	4 W	98.5 dB
32 W	107.5 dB	32 W	107.5 dB	2 W	95.5 dB
16 W	104.5 dB	16 W	104.5 dB	1 W	92.5 dB
8 W	101.5 dB	8 W	101.5 dB	.5 W	89.5 dB
4 W	98.5 dB				

Transducer	
Low Frequency Driver	1 x 203 mm (8.0 in) Polypropylene cone, butyl rubber surround
High Frequency Driver	25 mm (1.0 in) Convex aluminum tweeter with waveguide
Low Frequency Voice Coil	30.4 mm (1.2 in)
Crossover Frequency	3 kHz
Network Type	
Low Pass	12 dB per octave, 2nd order
High Pass	12 dB per octave, 2nd order
Enclosure Material	Injection molded ABS, glass fiber reinforced
Motor Board	Cast aluminum
Grille	Iridite-plated steel with powder-coat finish
Inputs	4 Pin, 5 mm Euroblock for individual or daisy chain connection
Colors	Black or white
Height	437.7 mm / 17.23 in
Diameter	376.5 mm / 14.82 in
Weight	9.2 kg / 20.5 lbs
Shipping Weight	11.5 kg / 25.5 lbs
Accessories	
Included	Hanging hardware, Euroblock connector & terminal weather boot
Optional	Surface-Mount Bracket (AC-RS-SM8)
Packaging	1 per box

¹ Frequency response is measured in half & full space and includes a low-frequency peak > +3 dB.

² Continuous power rating, EIA-426-B test.

³ 2.83 Volts at a distance of 1 meter.

SoundTube continually develops new product innovations and improvements. Updates to existing products without prior notice are an example of SoundTube's drive for constant improvement.

Key Features

- BroadBeam11[®] waveguide technology delivers a consistent dispersion pattern up to 10 kHz for maximum coverage area per speaker (EASE[™] documented).
- One 203 mm (8.0 in) polypropylene woofer and one 25 mm (1.0 in) convex aluminum tweeter with FerroFluid[™] cooling mounted to a proprietary cast-aluminum M8[™] baffle and heat sink.
- Weatherized components for indoor & outdoor applications.
- Includes hanging hardware with aircraft cables and integrated SpeedClamp[™] self-locking cable grip for fast, easy & secure installation. Also includes Euroblock connector & terminal weather boot.
- Patented ZeroReflection[™] enclosure technology for optimal sound reproduction & cabinet rigidity.
- Easy access 6-position selectable tap switch for 25, 70.7 and 100 Volt applications with voice coil/8 Ohm direct simplifies ordering and inventory tracking.
- Iridite-plated steel grille with protective powder-coated finish for lasting durability.
- 92.5 dB Sensitivity offers high-output capabilities & reduced amplification costs.
- UL 1480 listing, CE approval (EMC Directive 89/366/EEC, EN55020, EN55013), Mil-spec 810 & IEC529 pending.
- Also includes Euroblock connector & terminal weather boot.
- Optional accessory: AC-RS-SM8 bracket for surface-mount applications.
- High-quality black or white paint finish. Custom paint colors optional.

Description

The RS800i is an 8" 2-way ported speaker with an open-ceiling enclosure design that delivers extended low-end response (48 Hz) and optimal off-axis performance (up to 10 kHz, EASE[™] documented). SoundTube's proprietary BroadBeam11[®] waveguide tweeter system delivers consistent high-performance audio across the operating bandwidth. The RS800i speaker design incorporates a low-profile grille, proprietary M8[™] motor-board and 6-position tap switch with voice coil/8 Ohm direct. Hanging hardware is included & features SpeedClamp[™] self-locking cable grip for fast, easy & secure installation.

Frequency Response

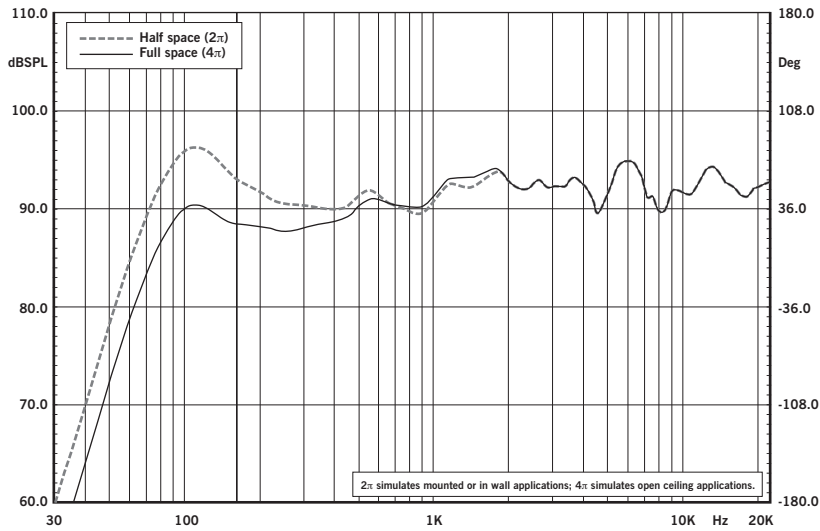

Phase/Impedance Reponse

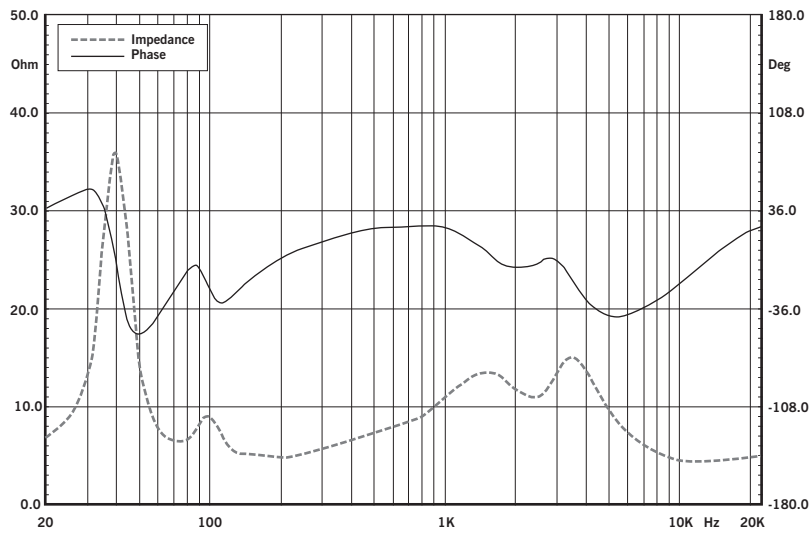

Beamwidth (-6dB)

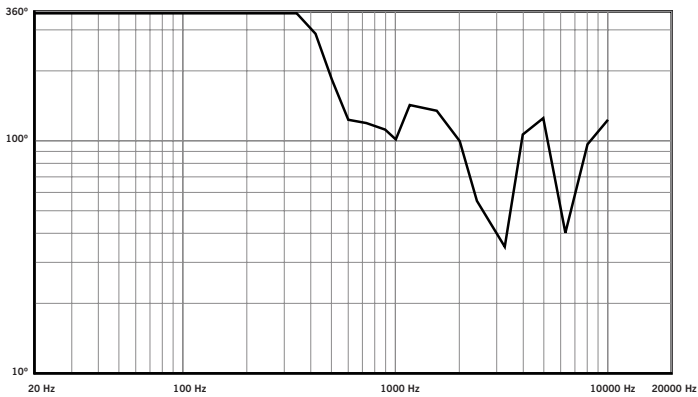

Directivity Index (DI)

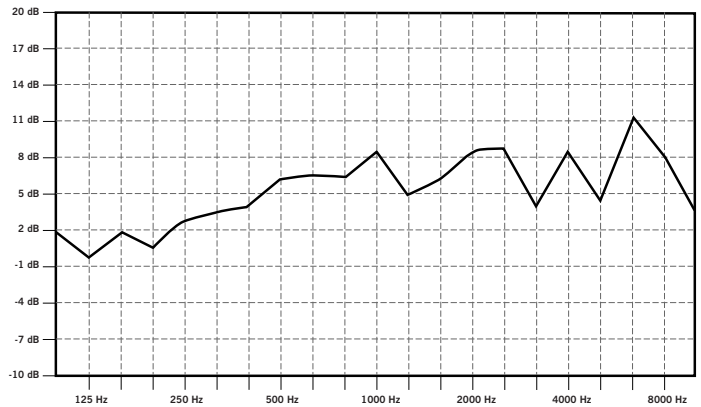

Applications

Designed for indoor & outdoor background to foreground SPL applications, the RS800i includes a single point mounting system for rapid open-ceiling installations. The 100° broad dispersion pattern (1 kHz – 10 kHz, EASE™ documented), true low-end response (48 Hz, -10 dB) and high sensitivity (92.5 dB 1W/1M) make the RS800i ideal for big box stores, fitness centers, sports bars, multi-purpose rooms, churches, airports, theme parks, ball-rooms, convention centers, casinos and other open-ceiling applications requiring background to foreground SPL. For applications where additional bass is required, SoundTube’s RS801i 8” subwoofer provides bass down to 40 Hz.

BroadBeam11® Wide Dispersion Technology

More than 3 years in development, SoundTube’s proprietary BroadBeam11® technology incorporates a high-frequency waveguide mated to a 1” convex aluminum tweeter. The BroadBeam11® high-frequency waveguide delivers a consistent dispersion

pattern across the upper registers of the frequency spectrum (up to 10 kHz, EASE™ documented). The result is an audio system with fewer speakers, reduced power needs, shorter installation time and cost savings on shipping & labor.

Patented SoundTube Technologies

SoundTube Entertainment is constantly developing new technologies that enhance audio product performance. SoundTube Entertainment innovations are protected by multiple U.S. & international patents, which explicitly cover SoundTube dispersion, enclosure & dome technologies. SoundTube Entertainment actively defends its patents in order to protect SoundTube resellers and end users.

Technical Data and Specification Tools

Technical Data

SoundTube Entertainment strives to provide complete and effective technical information and data to dealers, engineers and designers. All data are available from SoundTube Entertainment or at www.soundtube.com

Data Acquisition

All performance data acquired at SoundTube’s Technical Measurement Center (TMC) are analyzed using a variety of standard measurement techniques, including Measured Length Sequence (MLS) and Time Delay Spectrometry (TDS). Performance, development and data acquisition tools include: Gold Line TEF 20, CLIO, LMS, LEAP, and proprietary modeling software. EASE™ data are acquired through an automated TEF 20/Outline/EASE™ interface.

EASE™ Data – 3-D polar plots.

SoundTubeSPEC™ – Proprietary SoundTube speaker placement software.

Architectural Specifications

The loudspeaker shall consist of a 203 mm (8.0 in) low-frequency transducer and a 25 mm (1.0 in) high-frequency transducer with a crossover network installed in the ported enclosure. The low-frequency voice coil diameter shall be 30.4 mm (1.2 in).

Performance specifications of a typical production unit shall be as follows: Use-

Polar Plots

125 Hz

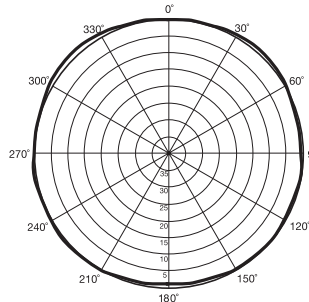

250 Hz

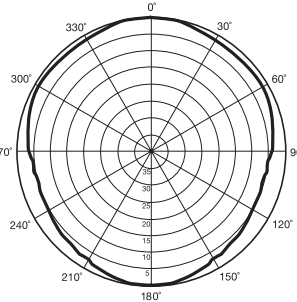

500 Hz

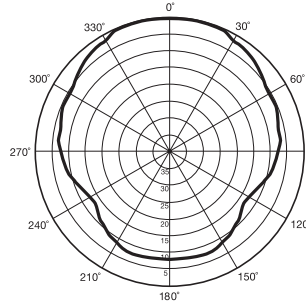

1000 Hz

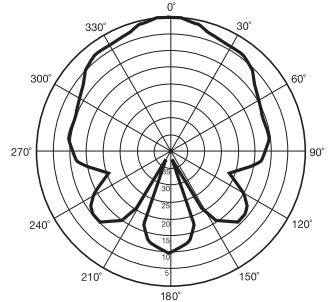

2000 Hz

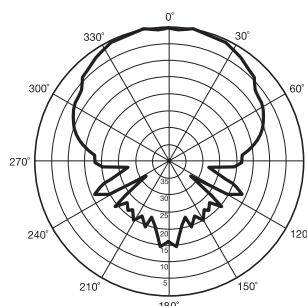

4000 Hz

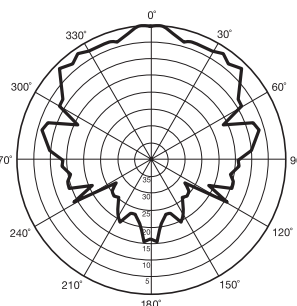

8000 Hz

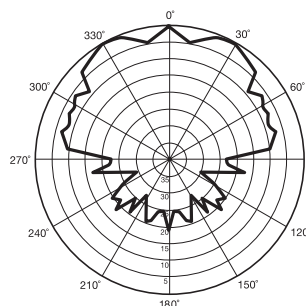

10000 Hz

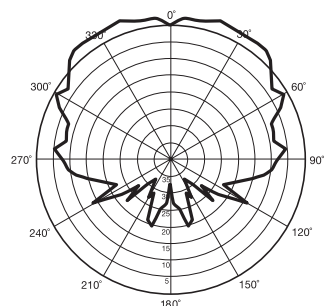

Mechanical Drawings

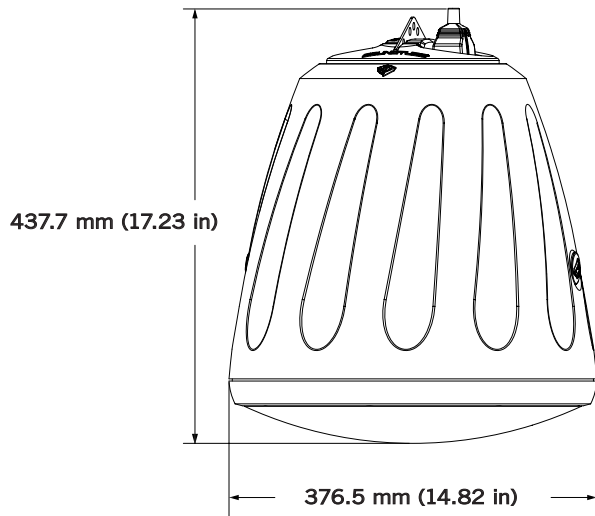

Included Accessories

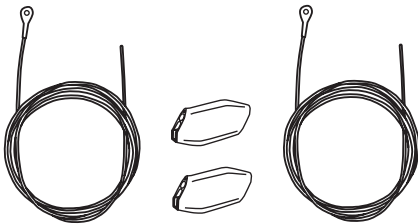

Hanging Hardware: Main & Safety Cables w/ SpeedClamp™

SoundTube's hanging cable kit incorporates hanging & safety cables & fasteners for an integrated and easy-to-install system. All cables are infinitely adjustable up to 2.74 M (9.0 ft).

Optional Accessory

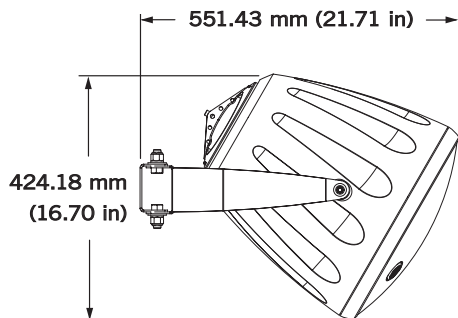

Surface-Mount Bracket (AC-RS-SM8)

able frequency response shall extend from 48 Hz – 22 kHz (-10 dB, half space, no external equalization). Measured sensitivity (2.83 Volt input, 1 meter) shall be at least 92.5 dB. The speaker shall have a nominal impedance of 8 Ohms and be available for 25, 70.7 & 100 Volt modes with voice coil/8 Ohm direct. The frequency-dividing network shall have a crossover frequency of 3 kHz with slopes of 12 dB per octave (2nd order) for both low & high pass filters. Rated power capacity shall be at least 125 Watts continuous power (RMS) and conform to EIA-426-B testing. Maximum continuous output at 1 meter shall be 112.5 dB.

The low-frequency transducer shall have a polypropylene cone with butyl rubber surround. The high-frequency transducer shall be constructed of aluminum with a proprietary BroadBeam11® waveguide.

Installation for the RS800i shall be by aircraft cable affixed to the speaker chassis via a carabiner. For seismic & safety redundancy, a secondary aircraft cable shall be included and attach to the speaker chassis via #10 bolt. The external wiring input connector shall be a 4-pin, 5 mm Euroblock for 8 Ohm or distributed systems and shall accept from 10 – 22 gauge wire. The system shall be for indoor & outdoor applications and shall have a weather-resistant terminal boot covering all wire connectors.

The enclosure shall be constructed of injection-molded, mineral-filled, glass-reinforced ABS. The grille shall be constructed of iridite-plated, powder-coated steel for lasting performance in the elements. Overall cabinet dimensions shall be no more than 437.7 mm (17.23 in) in height by 376.5 mm (14.82 in) in diameter. The RS800i shall include hanging hardware, Euroblock connector and weather-resistant terminal boot.

The system shall be the SoundTube RS800i with hanging hardware for both low & high impedance applications.

SoundTube Entertainment

6430 North Business Park Loop
 Park City, Utah 84098
 Phone 435.647.9555
 Fax 435.647.9666
 Toll Free 800.647.TUBE
 www.soundtube.com

All SoundTube products come with a 5-year limited warranty.

SoundTube Entertainment manufactures a complete line of speakers for:
Open-Ceiling • In-Ceiling • Surface-Mount • Outdoor • Sound-Focusing

All SoundTube products are designed and engineered in the USA.

Free Manuals Download Website

<http://myh66.com>

<http://usermanuals.us>

<http://www.somanuals.com>

<http://www.4manuals.cc>

<http://www.manual-lib.com>

<http://www.404manual.com>

<http://www.luxmanual.com>

<http://aubethermostatmanual.com>

Golf course search by state

<http://golfingnear.com>

Email search by domain

<http://emailbydomain.com>

Auto manuals search

<http://auto.somanuals.com>

TV manuals search

<http://tv.somanuals.com>