

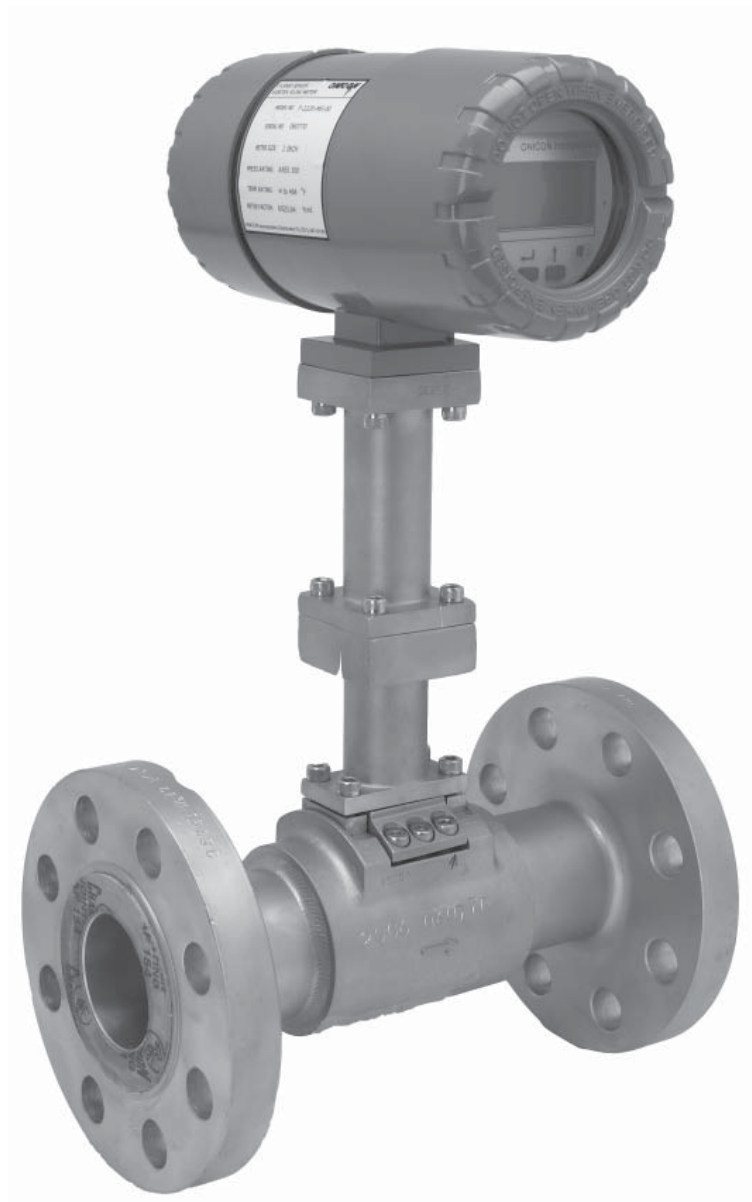

F-2200 Series Vortex Flow Meter Installation and Operation Guide



12-15-08

1500 North Belcher Road • Clearwater, FL 33765 • Tel (727) 447-6140 • Fax (727) 442-5699
www.onicon.com • sales@onicon.com

SAFETY INFORMATION

This meter was calibrated at the factory before shipment. To ensure correct use of the meter, please read this manual thoroughly.

Regarding This Manual:

- This manual should be passed on to the end user.
- Before use, read this manual thoroughly to comprehend its contents.
- The contents of this manual may be changed without prior notice.
- All rights reserved. No part of this manual may be reproduced in any form without ONICON's written permission.
- ONICON makes no warranty of any kind with regard to this material, including, but not limited to, implied warranties of merchantability and suitability for a particular purpose.
- All reasonable effort has been made to ensure the accuracy of the contents of this manual. However, if any errors are found, please inform ONICON.
- ONICON assumes no responsibilities for this product except as stated in the warranty.
- If the customer or any third party is harmed by the use of this product, ONICON assumes no responsibility for any such harm owing to any defects in the product which were not predictable, or for any indirect damages.

Safety Precautions:

The following general safety precautions must be observed during all phases of installation, operation, service, and repair of this product. Failure to comply with these precautions or with specific WARNINGS given elsewhere in this manual violates safety standards of design, manufacture, and intended use of the product. ONICON Incorporated assumes no liability for the customer's failure to comply with these requirements. If this product is used in a manner not specified in this manual, the protection provided by this product may be impaired.

The following symbols are used in this manual:



WARNING

Messages identified as WARNING contain information regarding the personal safety of individuals involved in the installation, operation or service of this product.



CAUTION

Messages identified as CAUTION contain information regarding the potential damage to the product or other ancillary products.



IMPORTANT NOTICE

Messages identified as IMPORTANT NOTICE contain information critical to the proper operation of the product.

F-2200 Series Vortex Flow Meter Installation and Operation Guide

Addendum

December 12, 2008

The drawing below illustrates the proper method for insulating the flow meter.



CAUTION

Insulating the entire neck of the flow meter will increase heat transfer to the electronics enclosure and may in some cases cause premature failure of the electronics.

F-2000 SERIES STEAM FLOW METER WITH INSULATION DETAIL

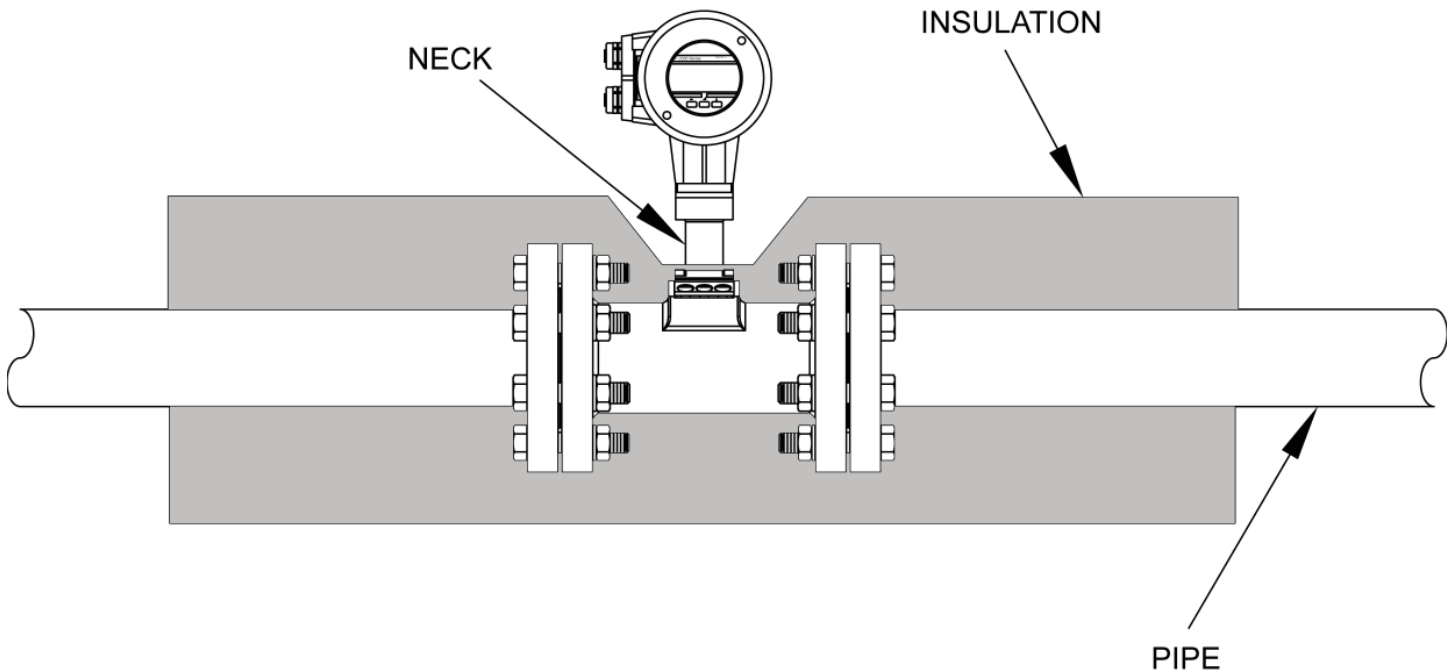

TABLE OF CONTENTS

1.0	INTRODUCTION	7
1.1	Purpose of This Guide	7
1.2	Principal of Operation	7
1.3	Features and Specifications	7
1.4	Additional Required Materials	9
1.5	Working Environment.....	9
1.6	Serial Number	9
2.0	UNPACKING.....	10
2.1	Checking That You Have Received Everything	10
3.0	INSTALLATION INFORMATION.....	11
3.1	Site Selection.....	11
3.1.1	Flow direction and meter position	11
3.1.2	Maximum allowable difference between inside of meter body and the connecting pipe.....	12
3.1.3	Straight, unimpeded inlet and outlet runs.....	13
3.1.4	Minimizing pipe vibration.....	14
3.1.5	Locating the meter in a pipeline that runs parallel to a wall	14
3.1.6	State of medium	14
3.1.6.1	Liquid Applications	14
3.1.6.2	Steam or compressed gas applications.....	14
3.2	Mechanical Installation	15
3.2.1	Orient the display for convenient viewing	15
3.2.1.1	Liquid applications	15
3.2.1.2	Steam or compressed gas applications.....	16
3.2.2	Flanged type connections to ANSI B16.5 (Schedule 40).....	16
3.2.3	Temperature Measurements.....	17
3.3	Wiring Terminations	17
4.0	START-UP & TROUBLESHOOTING	18
4.1	Start Up.....	18
4.2	Measurement Mode.....	18
4.3	Operating the Display	19
4.4	Error Handling.....	20
4.5	Troubleshooting Hints.....	21
5.0	FLOW STRAIGHTENER CATALOG SHEET	22

SECTION 1.0: INTRODUCTION

We, at ONICON INCORPORATED, would like to thank you for purchasing our F-2200 Series Vortex Flow Meter. As our valued customer, our commitment to you is to provide fast reliable service and assistance, while continuing to offer you new products to meet your growing flow measurement needs.

1.1 PURPOSE OF THIS GUIDE

The purpose of this guide is to provide installation and commissioning procedures and basic operating and servicing instructions for ONICON F-2200 Series Vortex Flow Meters.



WARNING

Only qualified service personnel should attempt to install or service this equipment. Serious injury may result from the improper installation or use of this equipment.

1.2 PRINCIPAL OF OPERATION

ONICON F-2000 series vortex flow meters utilize Karman's vortex street principal to detect changes in velocity in the medium flowing around the titanium shedder bar and through the meter body. A volumetric flow rate is then derived by utilizing the known cross-sectional area of the meter body and the average velocity of the medium. When provided with optional temperature and/or pressure compensation the F-2000 series flow meters are capable of calculating the required density corrections necessary to provide direct mass flow measurement of liquids, steam or gases.

1.3 FEATURES AND SPECIFICATIONS

CONSTRUCTION

Meter body:

Casting: 316 stainless steel for diameters up to 4"
304 stainless steel for 6" and 8" diameters

Shedder bar: Unalloyed titanium

Shedder bar seal: Ni plated Inconel

Damper pin o-ring:

Viton for, non-steam, -4° to 356° F
Kalrez 4079 for, non-steam, -4° to 428° F
Parofluor for steam, -4° to 464° F

Electronics enclosure:

Enclosure material: Die-cast aluminum
Enclosure viewing window: Tempered glass,
UV blocking

CALIBRATION

Each meter undergoes a 5 point velocity calibration from 0-250 ft/sec

PROGRAMMING

Each meter is programmed at the factory based on application specific data provided by the customer. Field re-programmable via keypad, with coded access for security.

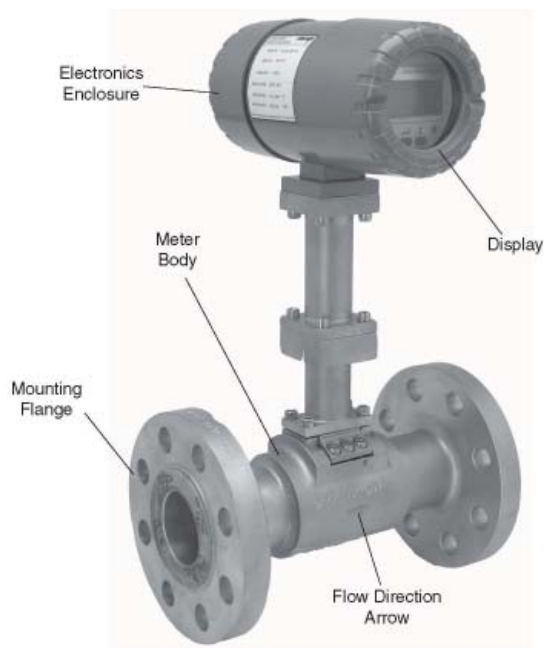

ACCURACY

Volumetric flow

±1% of reading accuracy (±2% for ¾" & smaller sizes)

Mass flow

±1.5% of reading accuracy (±2.5% for ¾" & smaller sizes)

OPERATING TEMPERATURE RANGE

Media temperature

25° to 464° F

Ambient temperature

0° to 132° F

DISPLAY / USER INTERFACE

16x64 dot matrix LCD with 3 button keypad and magnetic pin programming

OUTPUT SIGNALS

Rate: 4-20mA, loop-powered

Supply voltage range: 14-36 VDC

Minimum load resistance: 100 ohms

Maximum load resistance is calculated as follows:

$$\text{Max load} = \frac{V_s - 12V}{0.020A} \quad \text{Where } V_s = \text{supply voltage}$$

Total: Scaled output pulse, programmable

Optically isolated open collector, 0.5 hz maximum

Rating: 5-36 VDC, 100mA maximum

SUPPLY VOLTAGE:

14-36 VDC

PROCESS CONNECTIONS:

Standard: ANSI #300 flanges

Optional: ANSI #600 flanges

APPROVALS

Safety: Conforms to CE mark as per LVD, PED and EMC Directive

Enclosure: Conforms to IP 65 and IP 67

1.4 ADDITIONAL REQUIRED MATERIALS

Installer is responsible for providing suitable flanges and fasteners to connect the meter to the process piping. In addition, most installations will also require one reducer, one expander, pipe supports and a sufficient length of straight pipe (pipe diameter = meter size) to meet the installation requirements outlined in this manual. Use of an optional flow rectifier may be required in cases where the available space is not sufficient to allow for proper upstream straight pipe run.

1.5 WORKING ENVIRONMENT

ONICON F-2000 series vortex flow meters are designed for use in industrial environments that are free of corrosive liquids, fumes and excessive vibration. Do not expose the flow meter electronics enclosure to direct sunlight. Install a sunshade if necessary. Do not expose the flow meter to intense vibration. If necessary, provide additional support to the pipeline, at the meter location, to minimize vibration. The rotating design of the electronics enclosure makes it easier to connect the power and signal cables to the terminals in the rear of the enclosure. Rotate the enclosures as necessary before installing the meter.

The ambient operating temperature range is 0° to 132° F.

1.6 SERIAL NUMBER

The serial number for your F-2000 series vortex flow meter is located on the metal identification plate mounted on the side of the electronics enclosure. Please have this number available whenever you contact ONICON for assistance.

SECTION 2.0: UNPACKING

F-2000 series vortex flow meters are shipped in one package. Additional items, if ordered, will be shipped in separate packaging. All shipments are insured for damage in transit. Carefully inspect each package and notify the freight carrier and ONICON immediately if any items arrive damaged.

2.1 ENSURING THAT YOU HAVE RECEIVED EVERYTHING

Standard Documentation

Each ONICON flow meter is serialized and supplied with a comprehensive documentation package specifically prepared for this meter. It includes the following items. Please notify ONICON immediately if any discrepancies are found.

- Flow Meter
- The F-2000 Vortex Flow Meter Installation and Operation Guide
- The Flow Meter Calibration Data Sheet
- Magnetic programming pin

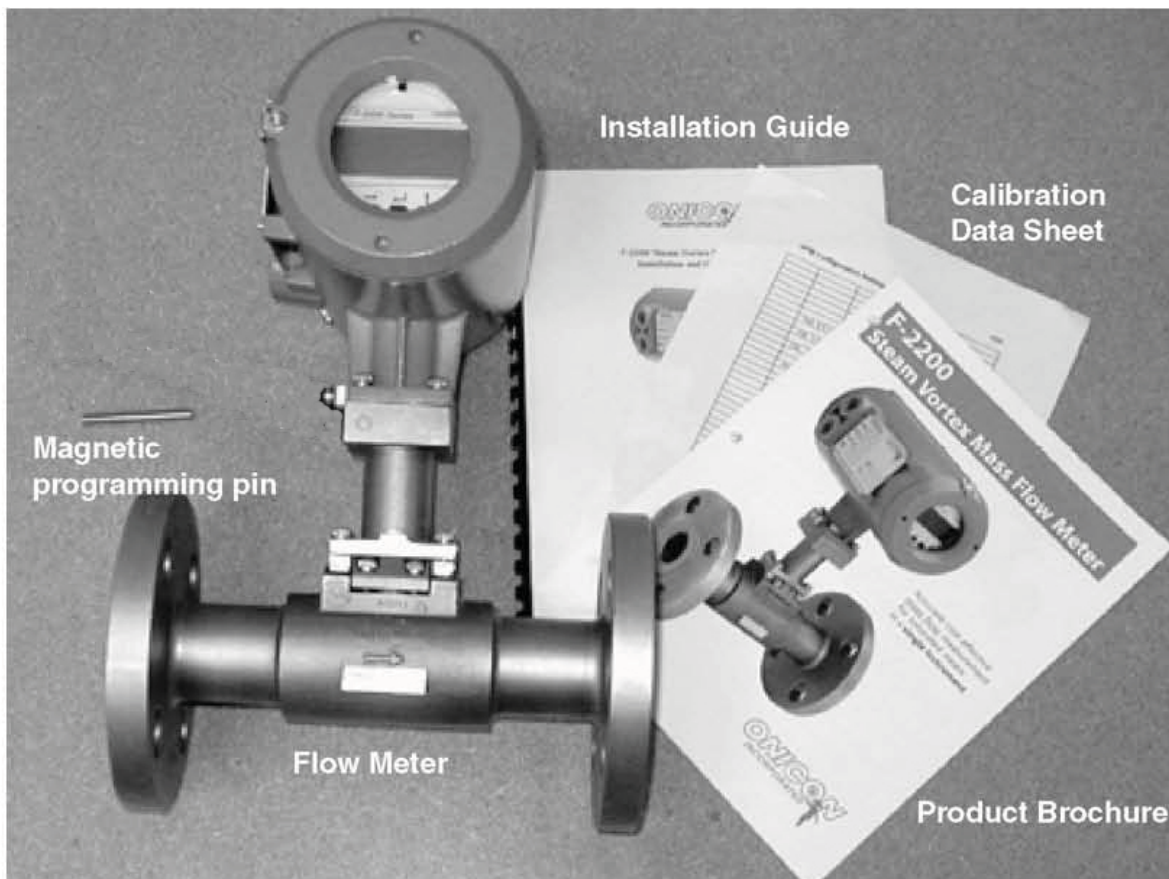

SECTION 3.0: INSTALLATION INFORMATION

The F-2000 series vortex flow meter must be installed by a technician qualified to work with pressurized liquid, steam and/or gas flow and must conform to all federal, state and local building codes. ONICON will be happy to assist with technical recommendations and to provide guidance via telephone or mail. On-site engineering, installation and service are also available, at additional cost.

3.1 SITE SELECTION

Careful attention in locating the point in the piping system where the flow meter will be installed will ensure accurate and reliable operation. When selecting an installation site, consider the criteria contained in Section 1.5 WORKING ENVIRONMENT, as well as the following:



CAUTION

The installation guidelines presented below are minimum requirements for the proper operation of this flow meter.

3.1.1 Flow Direction And Meter Position

The flow must always be in the direction of the arrow located on the meter body. This will orient the bluff side of the vortex shedder bar so that it faces the incoming flow (i.e. the upstream side).

For vertical pipe runs, flow must always be in the upward direction. Consult the factory in the event that a downward flowing pipe is the only available location.



The diagrams shown below illustrate the correct meter orientation for vertical and horizontal pipe.

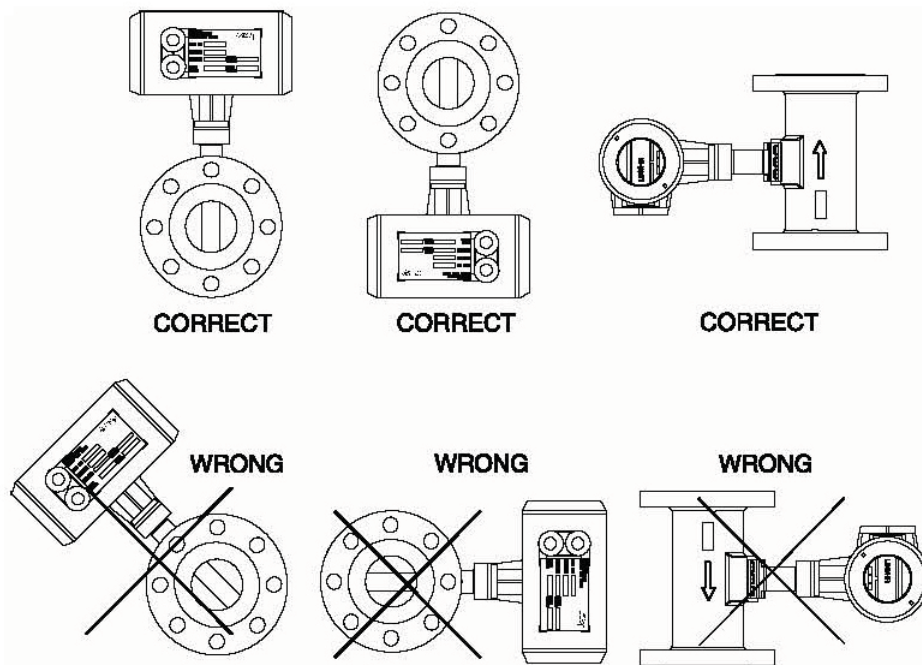

3.1.2 Maximum Allowable Difference Between Inside Diameter Of Meter Body And The Connecting Pipe

The table below provides the maximum allowable difference between the diameter of the flow meter body and the connecting pipe.

Nominal Meter Size (in.)	Meter Body Diameter (in.)	Maximum Pipe ID Difference (in.)
1"	1.05	0.016
1 1/2"	1.61	0.016
2"	2.07	0.024
3"	3.07	0.024
4"	4.03	0.024
6"	6.07	0.031
8"	7.98	0.039

Ensure that the bore of the locating pipes are smooth and without deposits, scaling, or welding beads.

3.1.3 Straight, Unimpeded Inlet And Outlet Runs

D = Meter Size (Nominal diameter in inches)

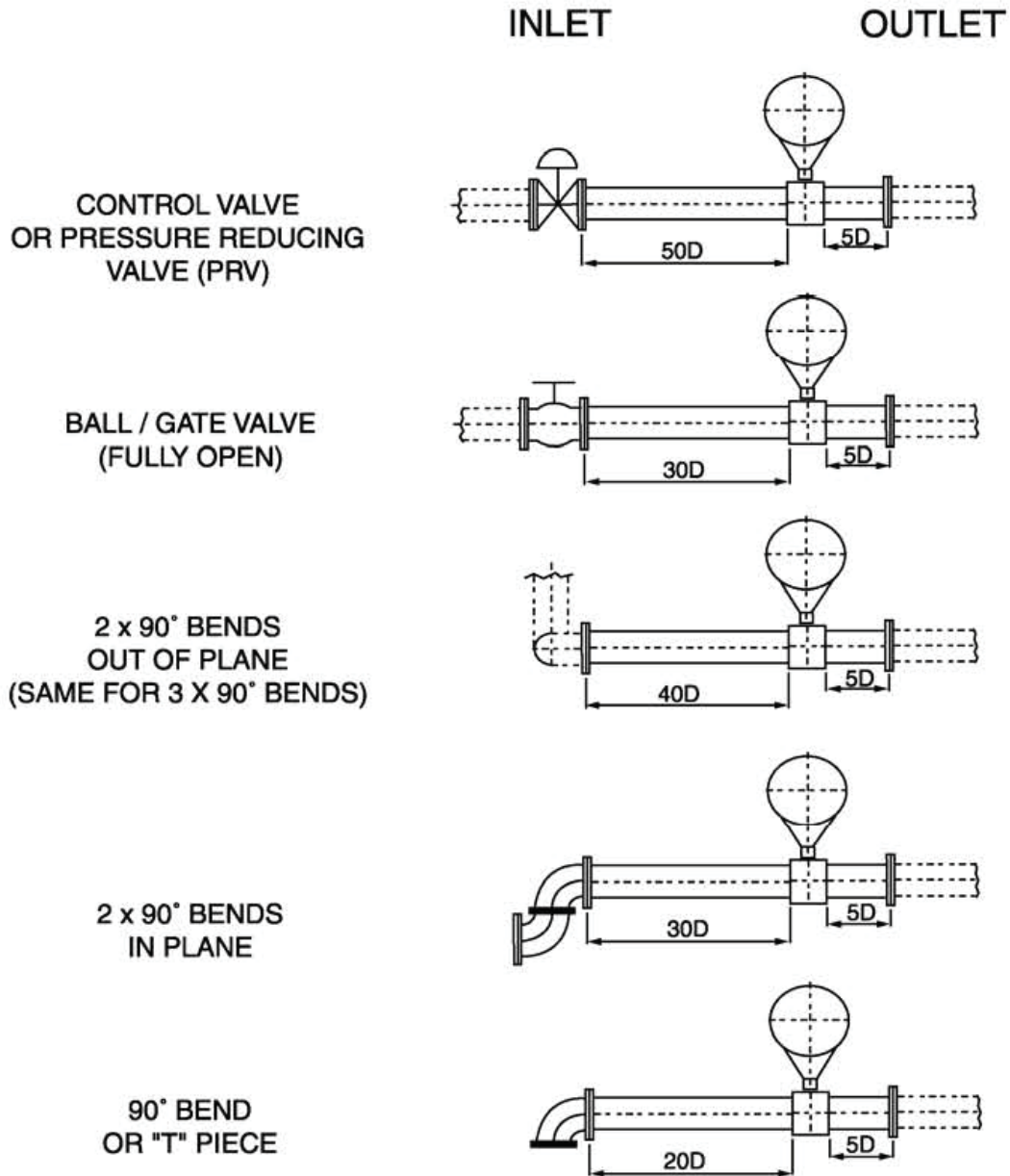

With a flow straightener, the inlet pipe length may be reduced by 50%. For example, with a control valve upstream, the inlet length is 25D instead of 50D. The minimum inlet pipe length including the flow straightener must always be at least 12D.

3.1.4 Minimizing Pipe Vibration

Pipe vibration caused, for example, by the action of pumps, valves, etc. will distort flow measurements, particularly at low flow velocities. To minimize the effects of vibration, support the pipeline on both sides of the meter in a direction perpendicular to both the pipeline and the shedder bar axis.

3.1.5 Locating The Meter In A Pipeline That Runs Parallel To A Wall

Wherever possible, the distance between the pipe centerline and the wall should be greater than 20". This will allow for access to the electronics enclosure compartment where wire terminations are made. If adequate space is not available, first connect all the cables to the terminals in the connection compartment (power supply and outputs) and then run the wires to an intermediate junction box (also see Section 3.2) before installing the meter.

3.1.6 State Of Medium

In all cases the meter requires a single-phase flow for proper operation. Liquid droplets in the gas or vapor, solid particles in the gas or liquid and gas bubbles in the liquid are not permitted.

3.1.6.1 Liquid Applications

When operating with liquids, the meter requires a minimum downstream pressure to prevent cavitation. The formula used to determine the minimum downstream pressure is as follows:

$$P_{ds}(\text{bar}_g) > = (2.9 * DP) + (1.3 * P_s) - 1.013$$

Where DP=pressure drop of the meter, in Bar, as determined by the ONICON sizing program and Ps=saturation pressure, in Bar, at the operating temperature.

For any fluid, a filter or strainer may be used to remove the solid particles. This is especially important for meter sizes below 1" where a filter or a strainer is required.

3.1.6.2 Steam Or Compressed Gas Applications

In case of steam or compressed gas, a moisture separator should be used 50D upstream of the meter if the dryness fraction is less than 95%.



IMPORTANT NOTE

Steam quality will affect the accuracy of the measurement. It is strongly recommended that a moisture separator be installed upstream of the inlet straight pipe run for anything less than 95% dry steam.

3.2 MECHANICAL INSTALLATION

3.2.1 Orient The Display For Convenient Viewing

Both the electronics enclosure and the display itself can be rotated to four different orientations to change the viewing angle for the display. If necessary, this should be done before the meter is installed.

3.2.1.1 Rotating the electronics enclosure

The electronics enclosure is attached to the meter body with (4) 5mm Allen head screws. To rotate the enclosure, you must first remove the screws and then carefully rotate the enclosure as needed. The interconnecting stem assembly is a conduit for wires that connect the sensors to the circuitry contained in the enclosure. Care must be taken to prevent these wires from being damaged when rotating the enclosure.

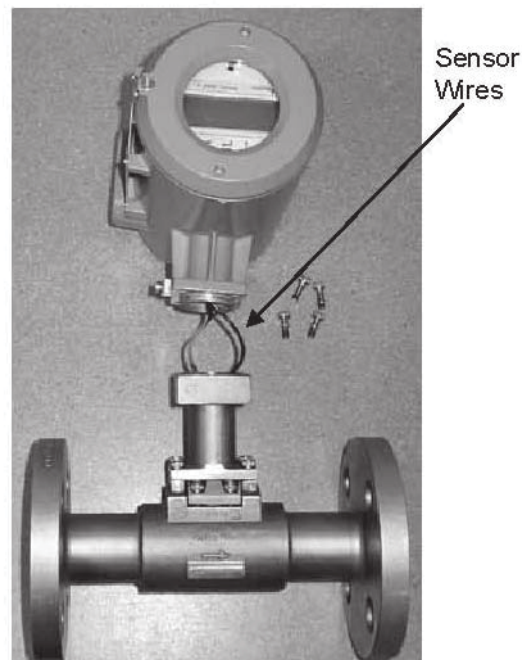
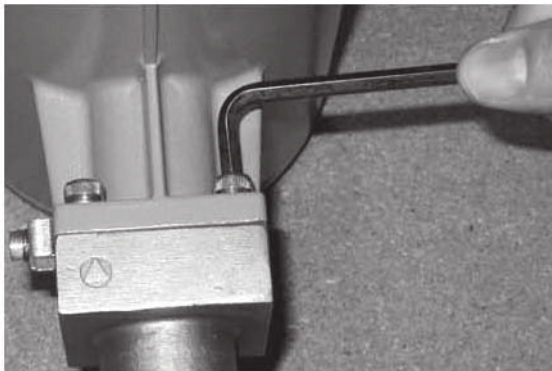

CAUTION

Make certain the sensor wires are not damaged when re-attaching the enclosure.

3.2.1.2 Rotating the display

To rotate the display, first unscrew the cover using the special tool provided for this purpose. Once the cover is removed, the (4) Philips head screws that secure the display are exposed. To rotate the display, remove these screws and carefully move it to the desired position making certain that the interconnecting cable is not damaged in the process.



CAUTION

- Do not remove enclosure covers in any wet environment
- Keep dirt and debris out of electronics enclosure
- Keep threads lubricated (silicone based lubricant)
- Do not over tighten covers. Use special tool for removal only.



Philips screws

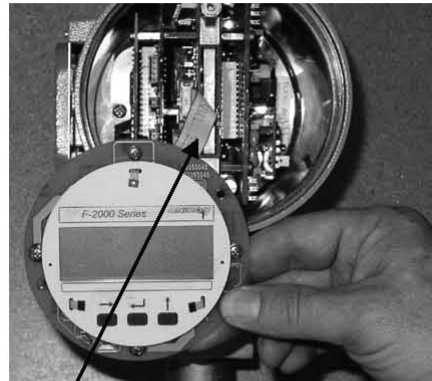

Interconnecting cable

3.2.2 Flanged-Type Connection To Ansi B16.5 (Schedule 40)

Meter sizes

3/8", 1/2", 3/4", 1", 1 1/2", 2", 3", 4", 6", 8"

Pipe flanges

To ANSI: #300 standard,
#600 optional

Gaskets are supplied with flanged units.

Center the flow meter by sight.

Check the flange connections for leak-tightness after the flow meter installation.



3.3.2 Temperature Measurements

ONICON F-2000 series vortex meters are supplied with an internal PT 1000 type RTD temperature sensor located within the shedder bar. This sensor provides an accurate temperature measurement at the point where the flow rate is being measured. Flow meters supplied with this option will display the medium temperature and deliver an output signal that is temperature compensated for mass and/or normalized flow.

3.3 WIRING TERMINATIONS

The standard F-2000 series vortex meter is a 2-wire loop powered device. Wiring connections are shown below.



CAUTION

- Do not remove enclosure covers in any wet environment
- Keep dirt and debris out of electronics enclosure
- Keep threads lubricated (silicone based lubricant)
- Do not over tighten covers. Use special tool for removal only.

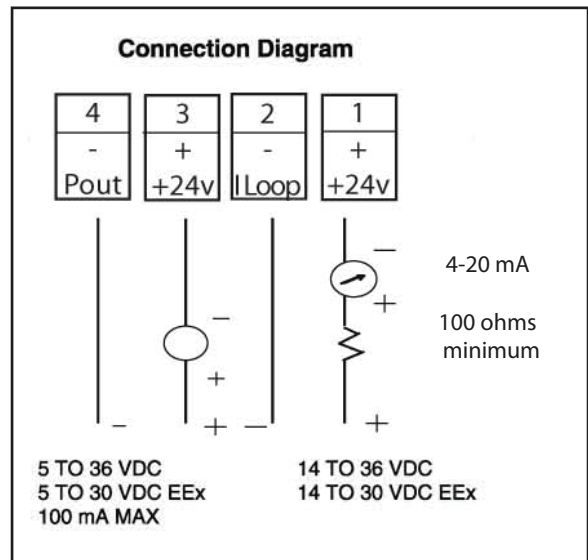
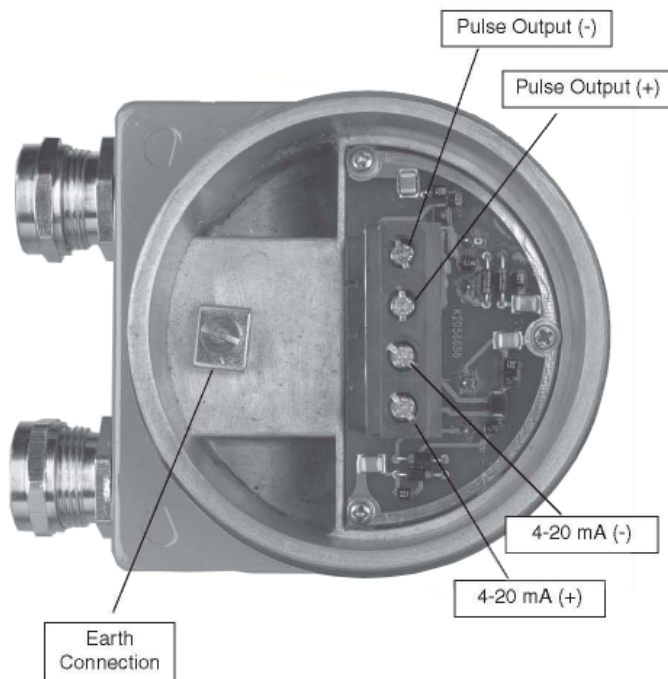

SECTION 4.0: START UP AND TROUBLESHOOTING

4.1 START UP

When the power is applied to the F-2000 series vortex meter, alphanumeric characters will appear on the display. Initially, the meter will operate in a “TEST” mode where self diagnostic checks are performed on the pre-amplifier and sensor circuits. Following this, configuration data is loaded from the non-volatile memory and the program advances to the measurement mode.



IMPORTANT NOTE

The meter should be installed and powered for at least 15 minutes before media is allowed to flow through the meter.



CAUTION

Flow velocity through the meter should be increased gradually until full flow is achieved.

4.2 MEASUREMENT MODE

In the measurement mode, the display indicates real-time flow, temperature and/or pressure data in the appropriate units. The top line of the display indicates the current measured value. The second line of the display indicates the programmed units of measurement.

There are two options for displaying data in the measurement mode. The display may be set to automatically scroll through each menu page or it may be set to manually step through the menu pages using the up arrow key to advance each page. Displays operating in the cyclic mode will advance through each page every 6 seconds.



IMPORTANT NOTE

When measuring steam flow, condensate may form on the cool surfaces of the meter and piping system when the system is started up for the first time (causing faulty measurement).

4.3 OPERATING THE DISPLAY

Please read the entire procedure before proceeding. Wiring diagrams are located in the Appendix. A worksheet for checking off the following steps and recording measured values is located on the next page.

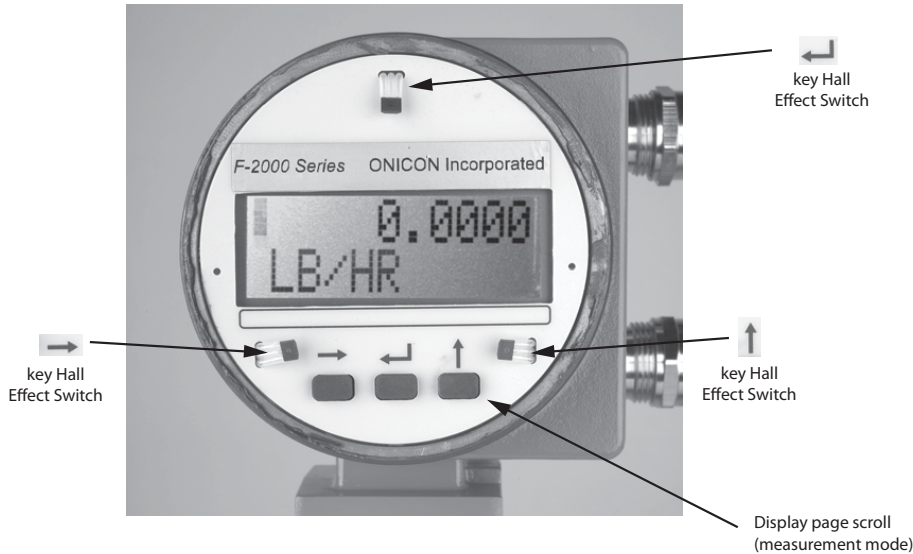

IMPORTANT NOTE

Do not attempt to enter the program mode without first contacting ONICON service.

There are 3 user interface switches located immediately below the display. Each switch performs a separate function. The table below describes the function of each switch. There are also 3 corresponding Hall Effect switches that perform the same functions. The Hall Effect switches may be activated without removing the display cover, using the magnet provided with the meter. Place the magnet against the cover in proximity to the Hall Effect switch to activate.

Interface Switch		Switch Function
	Scroll/Increment	Scroll through measurement mode menu pages.
PROGRAM MODE ONLY	Mode/Select	Enter programming mode - Contact ONICON for assistance in programming.
	Enter	Used in programming mode.



CAUTION

- Do not remove enclosure covers in any wet environment.
- Keep dirt and debris out of electronics enclosure.
- Keep threads lubricated (silicone based lubricant).
- Do not over tighten covers. Use special tool for removal only.

4.4 ERROR HANDLING

The meter can detect errors in either the test or the measurement modes. When in the measurement mode, a blinking vertical bar will appear in the top left corner of the display indicating an error has been detected. If the error reporting function is enabled, error messages will be displayed as separate menu pages. The first line of the error menu page indicates the total number of errors and the second line displays the error message. Measurement mode error messages are listed below.

Error Message (display second line)		Type Description	Corrective Action Required
NO SIGNAL		No signal from the vortex sensor	No flow. Also check for any other errors during power-on diagnostics. If there is a sensor problem, contact ONICON.
LOW FREQ.		Vortex frequency is too low	Check for flow rate lower than specified minimum. Contact ONICON.
HIGH FREQ.		Vortex frequency is too high	Check for flow rate higher than specified maximum. Contact ONICON.
LOW FLOW		Flow rate lower than specified range	Converter will continue to display actual flow rate. However, accuracy of measurement may suffer.
HIGH FLOW		Actual flow rate higher than specified range	Corrective action depends on application process. If the flow rate exceeds the maximum value it may damage the sensor physically.
INV. CONFIG.		Configuration data in non-volatile memory is not valid	Contact ONICON.
ISO FAIL	Checked during power-on only	Sensor isolation has failed	Contact ONICON.
AMP FAIL		Pre-amplifier section has failed	Contact ONICON.
PIEZO FAIL		Piezo wires broken	Contact ONICON.
CHECK INST		Flow signal quality is bad	Check: 1) Flow rate, if OK; 2) Check for excessive pipe vibration and upstream flow disturbances; 3) Contact ONICON.
LOW SIGNAL		Vortex signal amplitude too low	Check: 1) Flow rate, if OK; 2) Contact ONICON.
HIGH SIGNAL		Vortex sensor signal amplitude too high	This occurs in cases of high density medium. Check 1) Flow rate, if OK 2) Contact ONICON.
LOW.TEMP.PHY.		Operating temperature is lower than the physical limit	Take corrective action depending on the process.
HIGH.TEMP.PHY.		Operating temperature is higher than the physical limit	Take corrective action immediately. This will cause damage to the shedder bar as well as to the electronics.
T.SENS.SHORT		Temperature sensor/wires short circuit	Indicates a fault in the temperature sensor. Contact ONICON.
T.SENS.OPEN		Temperature sensor open circuit	

4.5 TROUBLESHOOTING HINTS

REPORTED PROBLEM	POSSIBLE SOLUTIONS
<p>A non-zero flow indicated when no actual flow is in the pipe.</p>	<ul style="list-style-type: none"> • Mains interference due to improper Earth ground connection. The protective Earth PE terminal should be properly grounded (see page 17). • Excessive mechanical vibration in the pipe. If so, support the pipeline near the meter perpendicular to both the axis of the pipe and the axis of the shedder bar. • This problem may also be solved by reducing the factory set gain. (Contact ONICON for assistance.) <p>NOTE: By reducing the gain, the minimum measurable flow rate will go up by the factor which is approximately equal to the square root of the gains (odd gains new gain). If the minimum flow with reduced gain is above the minimum flow which is required to be measured, then reducing the gain is not the permanent solution. Then the installaion should be corrected and also the vibrations should be eliminated.</p>
<p>“CHECK INST.” error is displayed when no flow is in the pipe.</p>	<p>The display should normally indicate 0.0 flow rate, LOW FLOW or LOW SIGNAL when there is no flow in the pipe. The additional CHECK INSTALL error (flow rate = 0.0 or some steady or fluctuating value) is an indication of:</p> <ul style="list-style-type: none"> • Improper/inadequate earthing • Excessive pipe vibration
<p>Flow rate indicated is 0.0 even with flow in the pipe.</p>	<ul style="list-style-type: none"> • The vortex sensor cable is disconnected or is not properly connected. • Flow sensor is faulty. Contact ONICON for assistance.
<p>The flow indicated responds to changes in the flow but the indicated value does not correspond to the actual flow rate. Also “CHECK INST.” Error may appear intermittently.</p>	<ul style="list-style-type: none"> • The meter is not properly centered on the pipeline. The axis of the meter bore should be aligned with that of the pipe. • Gaskets at the meter are protruding into the pipe bore. The gaskets must not project into the effective cross-section of the pipe. • Irregularities on the surface of the pipe bore. The pipe bore should be free from irregularities at the welded joints, dirt, deposits and excessive surface roughness. • The Vortex signal is distorted due to a bi-phase medium. Bi-phase media are not permitted. Use a moisture separator for wet steam applications to remove the moisture droplets from the steam. Use suitable filters in gas applications to remove solid particles from the flowing gas. • Incorrect angular position of the meter. Refer to Section 3.1.1 for the allowable mounting positions. • Insufficient upstream/downstream pipe lengths. Check that the upstream/downstream pipe lengths are of the correct minimum length as given in Section 3.1.3. • Error in meter factor K-Factor programming. Contact ONICON for assistance. • Check that the flow direction and the direction arrow on the meter body agree.

SECTION 5.0: FLOW STRAIGHTENER FOR VORTEX FLOW METERS



DESCRIPTION

The optional flow straightener accessory for ONICON F-2000 Series Vortex Flow Meters is a wafer-style flow conditioner that is designed to be installed between two recessed flanges (provided by installer) that are located a specified distance upstream of the flow meter.

Use of a flow straightener significantly reduces the upstream straight pipe length requirement for ONICON Vortex Flow Meters.

The size of the straightener should always match the meter size (as opposed to the original pipe size).

The flow straightener is made of 304/A 351 CF8 stainless steel.

TABLE 1 - ALL DIMENSIONS SHOWN IN INCHES

SIZE	DIM A	DIM B	DIM C	DIM D	NUMBER OF HOLES
2"	3.93	1.0625	.28	2.14	35
3"	5.31	1.0625	.43	3.24	35
4"	6.26	1.0625	.55	4.22	35
6"	8.50	1.0625	.78	6.07	35
8"	10.62	1.0625	1.02	7.98	35

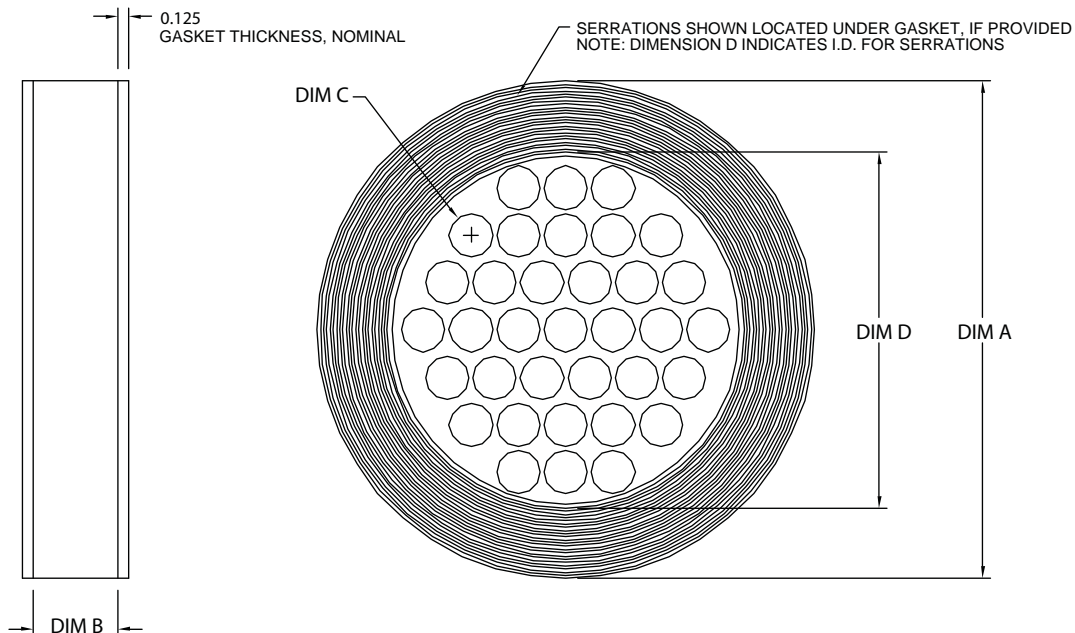

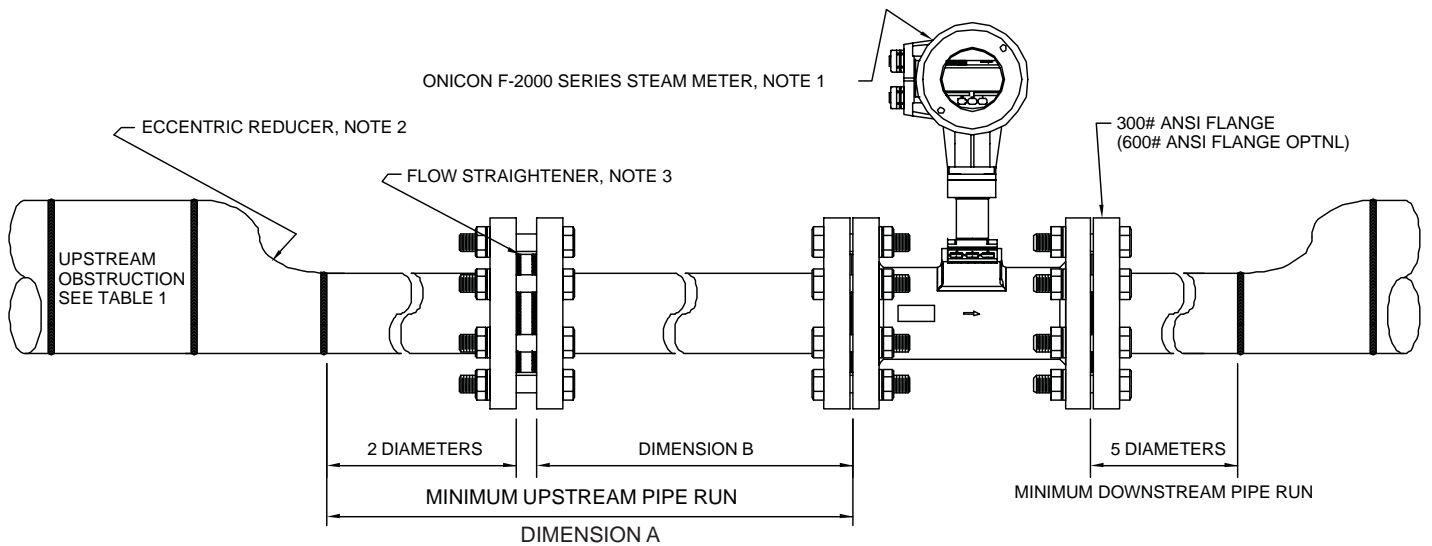

REQUIRED DIMENSIONS FOR INSTALLATIONS WITH FLOW STRAIGHTENER		
UPSTREAM OBSTRUCTION	DIMENSION A	DIMENSION B
	TOTAL UPSTREAM PIPE RUN	DISTANCE BETWEEN FLOW METER AND STRAIGHTENER
SINGLE 90	12 DIA	10 DIA
TEE	12 DIA	10 DIA
RDCR/EXPNDR	12 DIA	10 DIA
TWO 90'S SAME PLANE	17 DIA	15 DIA
BALL/GATE VALVE FULLY OPEN	17 DIA	15 DIA
TWO 90'S OUT OF PLANE	22 DIA	20 DIA
CONTROL VALVE	27 DIA	25 DIA
PRV	27 DIA	25 DIA

NOTES

1. Consult ONICON for meter size and applicable meter pipe run for each application. Install according to manufacturer's recommendations.
2. Provide eccentric reducer and expander when required.
3. Provide flow straightener when required to meet recommended minimum upstream pipe run requirements.
4. Flanges provided by contractor. Recessed flanges are required for wafer flow straightener installation.

Free Manuals Download Website

<http://myh66.com>

<http://usermanuals.us>

<http://www.somanuals.com>

<http://www.4manuals.cc>

<http://www.manual-lib.com>

<http://www.404manual.com>

<http://www.luxmanual.com>

<http://aubethermostatmanual.com>

Golf course search by state

<http://golfingnear.com>

Email search by domain

<http://emailbydomain.com>

Auto manuals search

<http://auto.somanuals.com>

TV manuals search

<http://tv.somanuals.com>