

# PHILIPS

AQ 4010 Radio Cassetterecorder

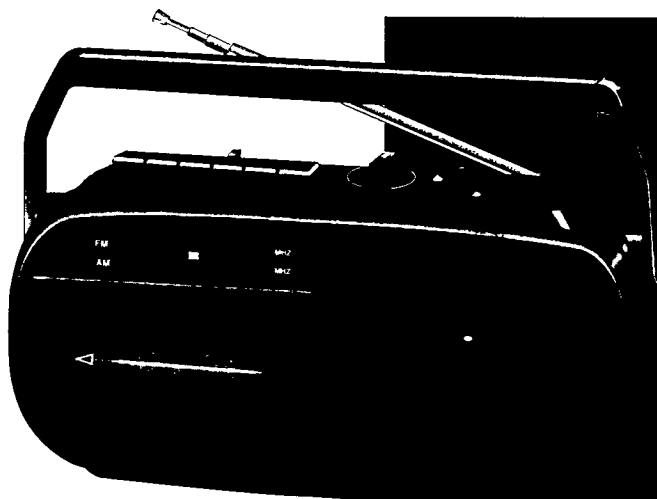

## (E) España

### Declaración de conformidad con normas

El que suscribe, en nombre y representación de  
**ACT Hong Kong, Division of  
 Philips China Hong Kong Group Company Ltd.**

declara, bajo su propia responsabilidad, que el

equipo : **Radiocasete**  
 fabricado por : **ACTeam Hong Kong**  
 en : **Far East**  
 marca : **Philips**  
 modelos : **AQ 4010**

objeto de esta declaración, cumple con la normativa  
 siguiente. Reglamento sobre Perturbaciones  
 Radioeléctricas, Real Decreto 138/1989, Anexo V.

Hecho en: Hong Kong, 11-1992

Firma:



Nombre: C. S. Lau  
 Cargo: Quality Assurance Manager

## (MEX) Mexico

NOM



NOM

Es necesario que lea cuidadosamente su instruccio-  
 nario de manejo.

Garantía y seguridad ..... página 30

## (DK) Danmark

Typeskiltet findes på undersiden af apparaten.  
 Dette produkt overholder kravene til radio-  
 interferens af Europæisk Fælleskab.

**Bemærk:** Netafbryderen er sekundært  
 indkoblet og afbryder ikke strømmen fra nettet.  
 Den indbyggede netdel er derfor tilsluttet til  
 lysnettet så længe netstikket sidder i  
 stikkontakten.

**Advarsel:** Usynlig laserudstråling ved åbning  
 når sikkerhedsafbrydere er ude af funktion.  
 Undgå udsættelse for stråling.

## (N) Norge

Typeskilt finnes på apparatets underside.

**Observer:** Nettbryteren er sekundært innkoplet.  
 Den innebygde nettdelen er derfor ikke frakoplet  
 nettet så lenge apparatet er tilsluttet nettkontakten.

## (GB) English

page 4

English

Illustrations

page 3

## (F) Français

page 7

Français

Illustrations

page 3

## (D) Deutsch

Seite 10

Deutsch

Abbildungen

Seite 3

## (NL) Nederlands

pagina 14

Nederlands

Afbeeldingen

pagina 3

## (E) Español

página 17

Español

Ilustraciones

página 3

## (I) Italiano

pagina 20

Italiano

Illustrazioni

pagina 3

## (S) Svenska

sida 23

Svenska

Figurer

sida 3

## (SF) Suomi

sivu 26

Suomi

Kuvat

sivu 3

## (AUS) Australia

Guarantee ..... page 29

## (NZ) New Zealand

Guarantee ..... page 29

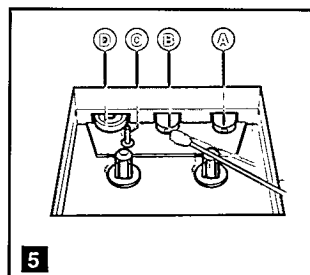
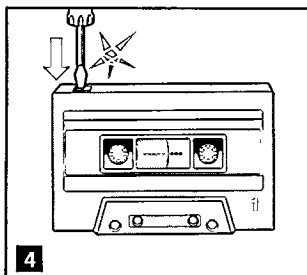
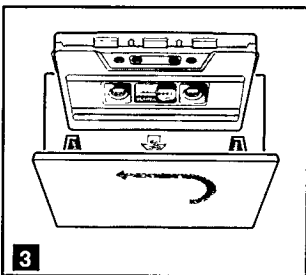
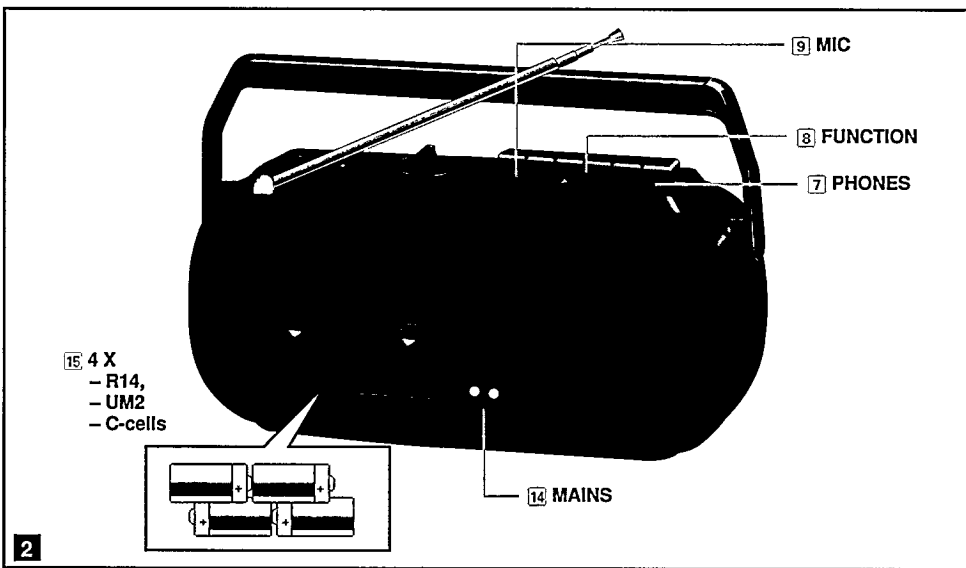
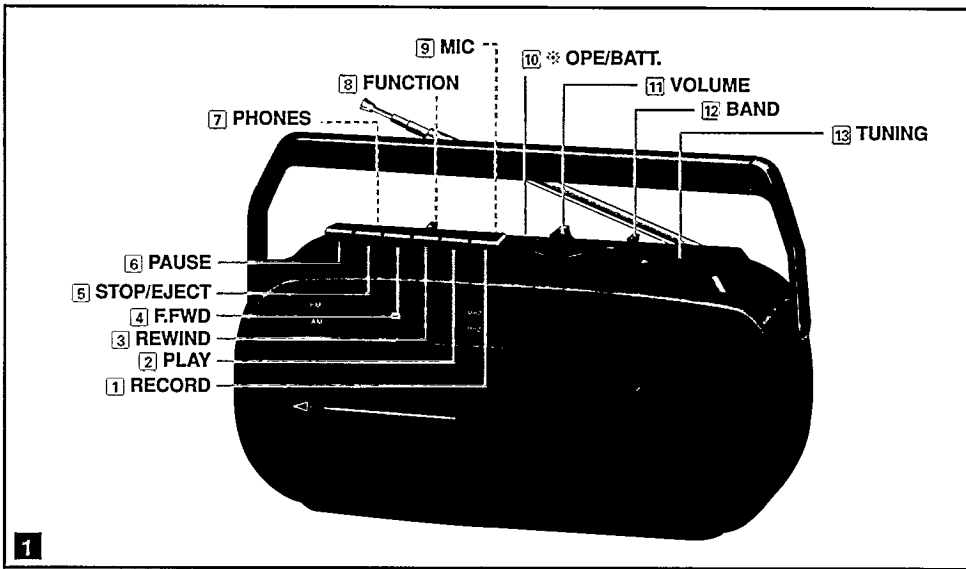

## TOP AND FRONT PANEL – Fig. 1

- ① **RECORD** ● button
- ② **PLAY** ◀ button
- ③ **REWIND** ▶▶ button
- ④ **F. FWD** ◀◀ button
- ⑤ **STOP/EJECT** ■ button
- ⑥ **PAUSE** || button
- ⑦ **PHONES** stereo headphone socket  
Connection for headphones (impedance 8–32 ohms)
- ⑧ **FUNCTION** switch  
To select the sound source:
  - **TAPE**: to switch to Tape mode
  - **RADIO**: to switch to Radio mode
- ⑨ **MIC**
- ⑩ **⊙ OPE/BATT** – lights up when power supply is on
- ⑪ **VOLUME** control – to adjust the volume level
- ⑫ **BAND** switch  
To select between FM and MW, and LW (not all versions).
- ⑬ **TUNING** control – to tune to radio stations

## SIDE AND BACK PANEL – Fig. 2

- ⑭ **AC MAINS** – socket for mains lead
- ⑮ **BATTERY** Compartment

## SUPPLY

### Battery supply

- Whenever convenient, use AC mains supply if you want to conserve battery life.
- Open the battery compartment (fig. 2).
- Insert as indicated four batteries, type R14, UM2 or C-cells (batteries not included).
- Remove the batteries if exhausted or if the unit is not to be used for a long period. The battery supply is switched off when the set is connected to the mains. To change over to battery supply, remove the plug from the MAINS socket ⑭.

### Mains supply

- Check that the mains voltage as shown on the type plate (at the back of the set) corresponds to your local mains supply. If it does

### *Important notes for users in the U.K.*

#### Mains Plug

This apparatus is fitted with an approved moulded 13 Amp plug.

To change a fuse in this type of plug proceed as follows:

- Remove fuse cover and fuse
- Fit new fuse which should be a BS1362 5 A, A.S.T.A. or BSI approved type
- Refit the fuse cover

If the fitted plug is not suitable for your socket outlets, it should be cut off and an appropriate plug fitted in its place.

If the mains plug contains a fuse, this should have a value of 5 A. If a plug without a fuse is used, the fuse at the distribution board should not be greater than 5 A.

**Note:** The severed plug must be destroyed to avoid a possible shock hazard should it be inserted into a 13 A socket elsewhere.

#### How to connect a plug

The wires in the mains lead are coloured with the following code: blue = neutral (N), brown = live (L). As these colours may not correspond with the colour markings identifying the terminals in your plug, proceed as follows:

- Connect the blue wire to the terminal marked N or coloured black.
- Connect the brown wire to the terminal marked L or coloured red.
- Do not connect either wire to the earth terminal in the plug, marked E (or +) or coloured green (or green and yellow).

Before replacing the plug cover, make certain that the cord grip is clamped over the sheath of the lead – not simply over the two wires.

**Copyright:** Recording and playback of material may require consent. See Copyright Act 1956 and The Performer's Protection Acts 1958 to 1972.

not, consult your dealer or service organisation.

- Connect the mains lead to the MAINS socket ⑭ and the wall socket. The mains supply is now connected.
- To disconnect the set from the mains, withdraw the mains plug from the wall socket.

## RADIO RECEPTION

- Set the FUNCTION switch ⑧ to RADIO.
- Adjust the sound with the VOLUME control ⑪. You may connect headphones with 3.5 mm plug to the socket ⑦ PHONES ⑦.
- Select the wave band using BAND selector ⑫ (LW not all versions).
- Tune to a desired radio station using TUNING control knob ⑬.
  - For FM, pull out the telescopic aerial. To improve FM-reception, incline and turn the aerial. Reduce its length if the FM-signal is too strong (very close to a transmitter).
  - For AM/MW and LW (LW not on all versions), the set is provided with a built-in aerial, so there is no need to use the telescopic aerial. The aerial can be directed by turning the whole set.
- The set is switched off if FUNCTION switch ⑧ is in the TAPE position and no buttons are pressed.

## CASSETTE PLAYBACK

- Set FUNCTION switch ⑧ to TAPE.
- Press STOP/EJECT ■ ⑤ and insert a cassette. For playback, any cassette type can be inserted (fig. 3).
- Adjust the sound with the VOLUME control ⑪ knob.
- Press PLAY ◀ ② and playback will start.
  - Playback stops when the tape in the deck reaches the end.
- To interrupt playback, press PAUSE II ⑥.
- To continue playback, press PAUSE II ⑥ again.
- Press STOP/EJECT ■ ⑤ if you want to stop the playback before the end of the tape.
  - When the end of the tape is reached, PLAY ◀ ② buttons are released.
- The set is switched off if FUNCTION switch ⑧ is in the TAPE position and no buttons are pressed.

### Winding the tape

- Press F.FWD ◀◀ button ④ to fast-forward the tape.
- Press REWIND ▶▶ button ③ to fast-rewind the tape.
- Press STOP/EJECT ■ ⑤ to stop fast-forward or fast rewind, or before the end of the tape..

## RECORDING

### Copyright

Recording is permissible insofar as copyright or other rights of third parties are not infringed.

### For U.K. only

Recording and Playback of material may require consent. See Copyright Act 1956 and The Performer's Protection Acts 1958 to 1972.

### Safeguarding a cassette against erasure

Accidental erasure can be prevented by breaking the small tab in the top left-hand corner of the back of the cassette. (See fig, 4). This protection can be reversed with a piece of adhesive tape placed over the same corner.

English

Français

Deutsch

Nederlands

Español

Italiano

Svenska

Suomi

**Recording**

- Press STOP/EJECT ■ ⑤ to open the cassette holder.
- Insert the cassette. For recording you must use a NORMAL cassette (IEC type I) on which the tabs have not been broken. The tape in the cassette is secured at both ends with leader tape. At the very beginning of the tape, no recording will take place during the first 7 seconds when the leader tape passes the recording heads.
- When monitoring during recording, adjust the sound with the VOLUME control ①. This control does not affect the recording.

**Recording from the radio**

- Set the FUNCTION switch ⑧ to RADIO.

**Recording from the built-in microphone**

- Set the FUNCTION switch ⑧ to TAPE.
- Set the VOLUME control ① to the minimum volume level.

**Starting and stopping**

- To start recording, press RECORD ● ① and PLAY ◀ ② simultaneously.
  - When the end of the tape is reached, the recording buttons are released.
- To interrupt recording, press PAUSE || ⑥.
- To continue recording, press PAUSE || ⑥ again.
- Press STOP/EJECT ■ ⑤ if you want to stop the recording before the end of the tape.
- The set is switched off if FUNCTION switch ⑧ is in the TAPE position and no buttons are pressed.

**MAINTENANCE****Cassette deck**

- To ensure good recording and playback quality, clean the parts A B C D indicated in fig. 5 after every 50 hours of operation or, on average, once a month.
- Open the cassette holder by pressing STOP/EJECT ■ ⑤.
- Use a cotton bud slightly moistened with alcohol or a special head cleaning fluid.
- Press PLAY ◀ ② and clean the rubber pressure roller D (fig. 5).
- Press PAUSE || ⑥ and clean the magnetic heads A B and the capstan C.
- After cleaning, press STOP/EJECT ■ ⑤.

**Remarks:**

- Fingerprints, dust and dirt on the set can be removed by using a soft, clean, and slightly damp leather cloth. Do not use any cleaning agents, since they may damage the cabinet.
- Do not expose the set and cassettes to rain, moisture, sand, or excessive heat from e.g. heating equipment or in motor cars parked in the sun.

*The type plate is located on the rear of the set.*

This product complies with the radio interference requirements of the European Community.

#### GUARANTEE AND SERVICE VALID FOR AUSTRALIA

The benefits given to the purchaser by this warranty are in addition to all other rights and remedies, which, under the Trade Practices Act or other Commonwealth or State law, the purchaser or owner has in respect of the product.

The Philips product carries the following warranties: C-series HiFi-systems: 12 months. Compact Disc Players: 12 months. Home Audio Systems: 6 months. Clock radios, portable radios, cassette recorders, cassette players and radio recorders: 90 days.

Any defect in materials or workmanship occurring within the specified period from the date of delivery, will be rectified free of charge by the retailer from whom this product was purchased.

*Note:* Please retain your purchase docket to assist prompt service.

#### Conditions of this warranty

1. All claims for warranty service must be made to the retailer from whom this product was purchased. All transport charges incurred in connection with warranty service or replacement will be paid by the purchaser.
2. These warranties do not cover batteries and extend only to defects in materials or workmanship occurring under normal use of the product where operated in accordance with our instructions.

**Philips Consumer Products Division,  
Technology Park  
Figtree Drive, Australia Centre  
Homebush 2140, New South Wales**

#### GUARANTEE AND SERVICE FOR NEW ZEALAND

Thank-you for purchasing this quality Philips product. The document you are now reading is your guarantee card.

#### Guarantee

Philips New Zealand Ltd guarantees this product against defective components and faulty workmanship for a period of 12 months. Any defect in materials or workmanship occurring within 12 months from the date of purchase subject to the following conditions will be rectified free of charge by the retailer from whom this product was purchased.

#### Conditions.

1. The product must have been purchased in New Zealand, and this guarantee card completed at time of purchase (this is your proof of the date of purchase).
2. The guarantee applies only to faults caused by defective components, or faulty workmanship on the part of the manufacturer.
3. The guarantee does not cover failures caused by misuse, neglect, normal wear and tear, accidental breakage, use on the incorrect voltage, use contrary to operating instructions, or unauthorised modification to the product or repair by an unauthorised technician.
4. Reasonable evidence (in the form of a sales docket or completed guarantee card) must be supplied to indicate that the product was purchased no more than 12 months prior to the date of your claim.
5. In the event of a failure, Philips shall be under no liability for any injury, or any loss or damage caused to property or products other than the product under guarantee.

*This guarantee does not prejudice your rights under common law and statute, and is in addition to the normal responsibilities of the retailer and Philips.*

#### How to claim.

Should your Philips product fail within the guarantee period, please return it to the retailer from whom it was purchased. In most cases the retailer will be able to satisfactorily repair or replace the product. However, should the retailer not be able to conclude the matter satisfactorily, or if you have other difficulties claiming under this guarantee, please contact

**The Guarantee Controller,  
Philips New Zealand Ltd.**

✉ P.O. Box 41.021

Auckland

☎ (09) 84 44 160

## GARANTIA PARA MEXICO

Este aparato está fabricado con materiales de alta calidad y ha sido cuidadosamente verificado. Philips, por lo tanto, da a usted una garantía de 12 meses a partir de su fecha de compra.

La garantía ampara la reposición de las piezas defectuosas debidas a fallas en su montaje o en los materiales, incluyendo la mano de obra necesaria para su reemplazo en nuestras Sucursales o talleres autorizados.

En caso de fallas en su aparato le rogamos se sirva poner en contacto con su distribuidor.

Esta garantía no cubrirá las averías que resulten como consecuencia de una instalación incorrecta del aparato, manifiesto maltrato o uso inadecuado del mismo.

Philips se obliga a reparar y devolver a usted su aparato en un plazo no mayor de 30 días hábiles contados a partir de la fecha de haber ingresado su aparato a uno de nuestros talleres.

Para que esta garantía sea válida, es necesario que el certificado que figura en la parte posterior de este instructivo haya sido debidamente llenado en el momento de la compra del aparato.

En caso de extravío del certificado con la presentación de la factura o remisión de su aparato podrá hacer efectiva la garantía correspondiente.

Si usted tiene alguna duda o pregunta que no le pueda solucionar su distribuidor, por favor ponerse en contacto con

**Oficinas Centrales de Servicio,  
Av. Coyoacán No. 1051, Col. del Valle,  
03100 MÉXICO, D.F.**

**☎ 5-75-20-22 o 5-75-01-00**



This sign on the packaging  
is only meant for Germany

Dieses Zeichen auf der Verpackung  
gilt nur für Deutschland

Le symbole sur l'emballage  
n'a que d'usage en Allemagne

Det symbol op de verpakking  
is alleen van toepassing in Duitsland

Esta señal en el paquete  
es válida sólo para Alemania

Questo simbolo sull'imballaggio  
è destinato solo alla Germania

Þetta merki þá innverkið er  
gælda: kun for Tyskland

Þetta merki þá embællið er  
endast ævsett for Tyskland

Tämä pakkausissa oleva merkki on  
tarkoitettu ainoastaan saksaa varten





# AQ 4010

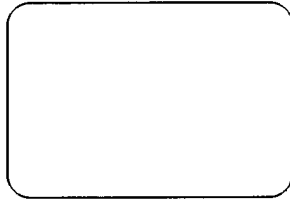

## Free Manuals Download Website

<http://myh66.com>

<http://usermanuals.us>

<http://www.somanuals.com>

<http://www.4manuals.cc>

<http://www.manual-lib.com>

<http://www.404manual.com>

<http://www.luxmanual.com>

<http://aubethermostatmanual.com>

Golf course search by state

<http://golfingnear.com>

Email search by domain

<http://emailbydomain.com>

Auto manuals search

<http://auto.somanuals.com>

TV manuals search

<http://tv.somanuals.com>