

CD Soundmachine

AZ 1500 · AZ 1505

Audio



Read this manual first!

Congratulations on purchasing this Philips product. We've included everything you need to get started. If you have any problems, Philips Representatives can help you get the most from your new product by explaining:

- Hookups,
- First Time Setup, and
- Feature Operation.

Do not attempt to return this product to the store.

For fast help, call us first!

1-800-531-0039

Thank you for making Philips a part of your home!



**Remote Control for
AZ1505 model only**

Let's make things better

Download from www.Softmanuals.com. All Manuals Search And Download.



PHILIPS

English

Français

Español

PHILIPS CONSUMER ELECTRONICS COMPANY

A Division of Philips Electronics North America Corporation
Knoxville, Tennessee 37914-1810, U.S.A.

Meet Philips at the Internet

<http://www.philipsusa.com>

AZ 1500
AZ 1505



3140 115 2895.1



1

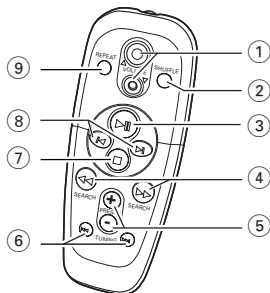
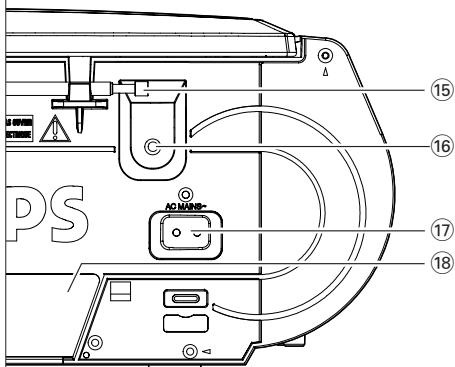
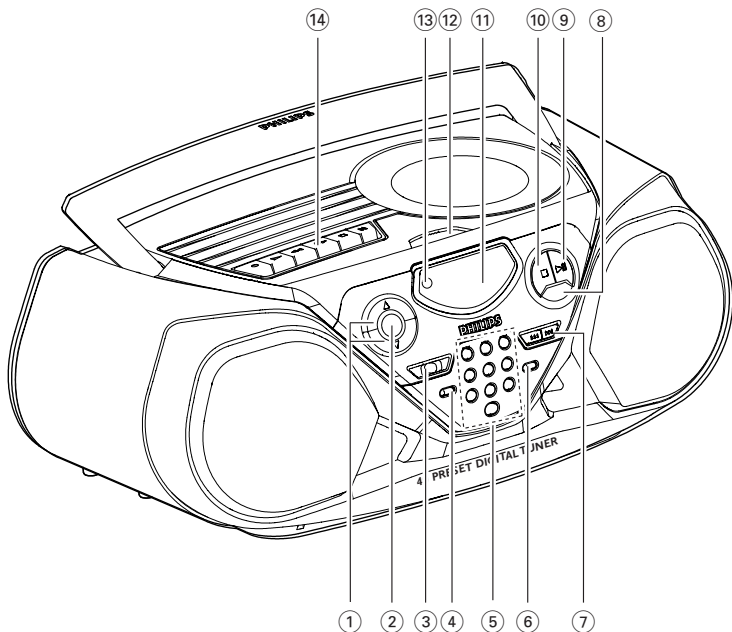

**Remote Control for
AZ1505 model only**

2



3

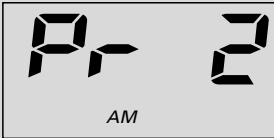

4

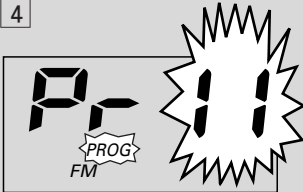

5



6

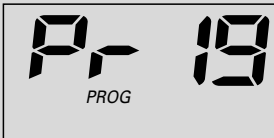

7

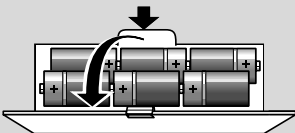

8

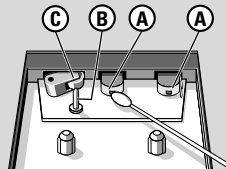
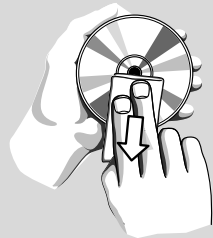
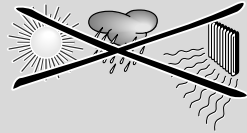

9

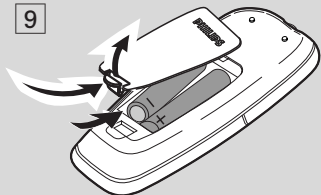

English: This digital apparatus does not exceed the Class B limits for radio noise emissions from digital apparatus as set out in the Radio Interference Regulations of the Canadian Department of Communications.

Français: Cet appareil numérique n'émet pas de bruits radioélectriques dépassant les limites applicables aux appareils numériques de Classe B prescrites dans le Règlement sur le Brouillage Radioélectrique édicté par le Ministère des Communications du Canada.

The set complies with the FCC-Rules, Part 15 and with 21 CFR 1040.10.

Operation is subject to the following two conditions:

- 1. This device may not cause harmful interference, and*
- 2. This device must accept any interference received, including interference that may cause undesired operation.*

L'appareil répond aux normes FCC, Part 15 et 21 CFR 1040.10.

Fonctionnement soumis aux deux conditions suivantes :

- 1. Cet appareil ne doit pas provoquer d'interférences nuisibles, et*
- 2. Cet appareil doit accepter toute interférence reçue, y compris les interférences susceptibles de provoquer un fonctionnement peu satisfaisant.*

El aparato cumple las normas FCC, Parte 15 y 21 CFR 1040.10.

Funcionamiento dependiente de dos condiciones siguientes:

- 1. Este aparato no puede provocar interferencia dañina, y*
- 2. Este aparato debe aceptar cualquier interferencia recibida, incluyendo las interferencias que pueden provocar un funcionamiento insuficiente.*

Return your Warranty Registration card today to ensure you receive all the benefits you're entitled to.

- Once your Philips purchase is registered, you're eligible to receive all the privileges of owning a Philips product.
- So complete and return the Warranty Registration Card enclosed with your purchase at once, and take advantage of these important benefits.

Warranty Verification

Registering your product within 10 days confirms your right to maximum protection under the terms and conditions of your Philips warranty.

Owner Confirmation

Your completed Warranty Registration Card serves as verification of ownership in the event of product theft or loss.

Model Registration

Returning your Warranty Registration Card right away guarantees you'll receive all the information and special offers which you qualify for as the owner of your model.

Know these
safety symbols



 This “bolt of lightning” indicates uninsulated material within your unit which may cause an electrical shock. For the safety of everyone in your household, please do not remove product covering.

 The “exclamation point” calls attention to features for which you should read the enclosed literature closely to prevent operating and maintenance problems.

For Customer Use

Enter below the Serial No. which is located on the rear of the cabinet. Retain this information for future reference.

Model No. _____

Serial No. _____

WARNING: TO PREVENT FIRE OR SHOCK HAZARD, DO NOT EXPOSE THIS EQUIPMENT TO RAIN OR MOISTURE.

CAUTION: To prevent electric shock, match wide blade of plug to wide slot, and fully insert.

IMPORTANT SAFETY INSTRUCTIONS

1. Read these instructions.
2. Keep these instructions.
3. Heed all warnings.
4. Follow all instructions.
5. Do not use this apparatus near water.
6. Clean only with a dry cloth.
7. Do not block any of the ventilation openings. Install in accordance with the manufacturers instructions.
8. Do not install near any heat sources such as radiators, heat registers, stoves, or other apparatus (including amplifiers) that produce heat.

9. Do not defeat the safety purpose of the polarized or grounding-type plug.

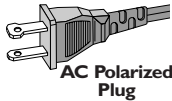

A polarized plug has two blades with one wider than the other. A grounding type plug has two blades and a third grounding prong. The wide blade or the third prong are provided for your safety. If the provided plug does not fit into your outlet, consult an electrician for replacement of the obsolete outlet.

10. Protect the power cord from being walked on or pinched, particularly at plugs, convenience receptacles, and the point where they exit from the apparatus.
11. Only use attachments/accessories specified by the manufacturer:

12.  Use only with a cart, stand, tripod, bracket, or table specified by the manufacturer or sold with the apparatus. When a cart is used, use caution when moving the cart/apparatus combination to avoid injury from tip-over.

13. Unplug this apparatus during lightning storms or when unused for long periods of time.
14. Refer all servicing to qualified service personnel. Servicing is required when the apparatus has been damaged in any way, such as if the power-supply cord or plug is damaged, liquid has been spilled or objects have fallen into the apparatus, or when the apparatus has been exposed to rain or moisture, does not operate normally, or has been dropped.

15. Battery usage **CAUTION** – To prevent battery leakage which may result in bodily injury or damage to the unit:

- Install **all** batteries correctly, + and - as marked on the unit.
- Do not mix batteries (**old** and **new** or **carbon** and **alkaline**, etc.).
- Remove batteries when the unit is not used for a long time.

EL 6475-E002: 01/3

Class II equipment symbol



This symbol indicates that the unit has a double insulation system.
Download from www.Somanuals.com. All Manuals Search And Download.

LIMITED WARRANTY

PORTABLE AUDIO

One Year Free Exchange

This product must be carried in for an exchange.

WHO IS COVERED?

You must have proof of purchase to exchange the product. A sales receipt or other document showing that you purchased the product is considered proof of purchase. Attach it to this owner's manual and keep both nearby.

WHAT IS COVERED?

Warranty coverage begins the day you buy your product. For one year thereafter, a defective or inoperative product will be replaced with a new, renewed or comparable product at no charge to you. A replacement product is covered only for the original warranty period. When the warranty on the original product expires, the warranty on the replacement product also expires.

WHAT IS EXCLUDED?

Your warranty does not cover:

- labor charges for installation or setup of the product, adjustment of customer controls on the product, and installation or repair of antenna systems outside of the product.
- product repair and/or part replacement because of misuse, accident, unauthorized repair or other cause not within the control of Philips Consumer Electronics Company.
- reception problems caused by signal conditions or cable or antenna systems outside the unit.
- a product that requires modification or adaptation to enable it to operate in any country other than the country for which it was designed, manufactured, approved and/or authorized, or repair of products damaged by these modifications.
- incidental or consequential damages resulting from the product. (Some states do not allow the exclusion of incidental or consequential damages, so the above exclusion may not apply to you. This includes, but is not limited to, prerecorded material, whether copyrighted or not copyrighted.)
- a product used for commercial or institutional purposes.

WHERE IS EXCHANGE AVAILABLE?

You may exchange the product in all countries where the product is officially distributed by Philips Consumer Electronics Company. In countries where Philips Consumer Electronics Company does not distribute the product, the local Philips service organization will attempt to provide a replacement product (although there may be a delay if the appropriate product is not readily available).

BEFORE REQUESTING EXCHANGE...

Please check your owner's manual before requesting an exchange. Adjustments of the controls discussed there may save you a trip.

EXCHANGING A PRODUCT IN U.S.A., PUERTO RICO OR U.S. VIRGIN ISLANDS...

Contact your dealer to arrange an exchange. Or, ship the product, insured and freight prepaid, and with proof of purchase enclosed, to the address listed below.

Small Product Service Center

Philips Service Company

907 Snapps Ferry Road, Plant 2, Building 6

Greenville, TN 37743

(In U.S.A., Puerto Rico and U.S. Virgin Islands, all implied warranties, including implied warranties of merchantability and fitness for a particular purpose, are limited in duration to the duration of this express warranty. But, because some states do not allow limitations on how long an implied warranty may last, this limitation may not apply to you.)

EXCHANGING A PRODUCT IN CANADA...

Please contact Philips at:

1-800-661-6162 (French Speaking)

1-800-363-7278 (English Speaking)

(In Canada, this warranty is given in lieu of all other warranties. No other warranties are expressed or implied, including any implied warranties of merchantability or fitness for a particular purpose. Philips is not liable under any circumstances for any direct, indirect, special, incidental or consequential damages, howsoever incurred, even if notified of the possibility of such damages.)

TO GET OUT-OF-WARRANTY EXCHANGE...

In U.S.A., Puerto Rico or U.S. Virgin Islands, contact Philips Service Company at (800) 531-0039 to obtain the cost of out-of-warranty exchange. Then carefully pack the product and ship it to the Small Product Service Center (address listed above). In Canada, call the phone number listed above under "Exchanging a Product in Canada" to obtain the cost of out-of-warranty exchange.

REMEMBER...

Please record the model and serial numbers found on the product below. Also, please fill out and mail your warranty registration card promptly. It will be easier for us to notify you if necessary.

MODEL # _____

SERIAL # _____

This warranty gives you specific legal rights. You may have other rights which vary from state/province to state/province.

Philips Service Solutions Group, P.O. Box 2976, Longview, Texas 75606, (903) 242-4800

EL6095T002 / MAC5433 / 1-97

ACCESSORIES

- 1 x AC power cord
- 1 x Remote Control (for **AZ1505** model only)

TOP AND FRONT PANEL (See [1])

- VOLUME ▲, ▼** - to adjust volume level.
- DBB (Dynamic Bass Boost)** - activates a more vivid bass response.
- POWER slider** - selects **TAPE/ RADIO/ CD** function and also the power off switch (**TAPE/ OFF**).
- BAND** - selects waveband.
- 0-9:** - digit panel
CD: - track selection and direct playback;
RADIO: - selecting a preset station.
- PROGRAM**
CD: - programs tracks and reviews the program;
Tuner: - programs preset radio stations.
- SEARCH ◀◀, ▶▶**
CD: - searches backward and forward within a track;
- skips to the beginning of a current track/ previous/ later track.
RADIO: - (down, up) tunes to radio stations.
- MODE** - selects different play modes: e.g. **REPEAT** or **SHUFFLE** (random) order.
- ▶II** - starts or pauses CD playback.
- - to stop playback;
- erases a CD program.
- Display** - shows the status of the set.
- LIFT TO OPEN** - lift here to open CD-tape door.
- REMOTE SENSOR** - (for **AZ1505** model only) infrared sensor for remote control.
- CASSETTE RECORDER keys:**
RECORD ● - to start recording.
PLAY ▶ - to start playback.
SEARCH ◀◀ / ▶▶ - fast rewinds/ winds tape.
STOP ■ - stops tape.
PAUSE II - pauses playback or recording.

BACK PANEL

- Telescopic antenna** - improves FM reception.
- 🎧** - 3.5 mm stereo headphone jack.
Note: The speakers will be muted when headphones are connected to the set.
- AC MAINS** - inlet for power cord.
- Battery compartment** - for 6 batteries, type **R-14, UM2** or **C-cells**.

REMOTE CONTROL (for AZ1505 model only)

- VOLUME ▲, ▼** - adjusts volume level.
- SHUFFLE** - plays all CD tracks in random order.
- ▶II** - starts or pauses CD playback.
- SEARCH ◀◀, ▶▶** - searches backwards/ forwards within a track.
- PRESET +, -** (up, down) - selects a preset radio station.
- TUNING ◀◀, ▶▶** (down, up) - tunes to tuner stations.
- - to stop playback;
- erases a CD program.
- ◀, ▶** - skips to the beginning of a current track previous/ subsequent track.
- REPEAT** - repeats a track /program/ entire CD.

CAUTION

Use of controls or adjustments or performance of procedures other than herein may result in hazardous radiation exposure or other unsafe operation.

POWER SUPPLY

Whenever convenient, use the AC power supply to conserve battery life. Make sure you remove the power plug from the set and wall outlet before inserting batteries.

Batteries (not included)

- Insert 6 batteries, type **R-14, UM-2** or **C-cells**, (preferably alkaline) with the correct polarity. (See [7])
- Remote control (AZ1505 model only)**
Insert 2 batteries, type **AAA, R03** or **UM4** (preferably alkaline). (See [9])

IMPORTANT!

- Incorrect use of batteries can cause electrolyte leakage and will corrode the compartment or cause the batteries to burst.
- Do not mix battery types: e.g. alkaline with carbon zinc. Only use batteries of the same type for the set.
- When inserting new batteries, do not try to mix old batteries with the new ones.
- **Batteries contain chemical substances, so they should be disposed of properly.**

Using AC Power

1. Check if the AC power supply, as shown on the **type plate located on the bottom of the set**, corresponds to your local power supply. If it does not, consult your dealer or service center.
2. Connect the power cord to the wall outlet.
3. To disconnect the power supply, unplug the set from the wall outlet.

The type plate is located on the bottom of the set.

BASIC FUNCTIONS

Switching on and off and selecting function

1. To switch on, adjust the **POWER slider** to select: **CD**, **RADIO** or **TAPE** function, and operate the respective function controls.
2. To switch off, adjust the **POWER slider** to select **TAPE/OFF** and make sure all the cassette keys are released.

Note : The DBB setting, tuner presets and the volume will be retained in the set's memory.

Adjusting volume and sound (See [2])

1. Press the **VOLUME** ▲ or ▼ controls to adjust the volume.
2. Press **DBB** once or more to select dynamic bass boost on or off.

DIGITAL TUNER

Tuning to radio stations

1. Adjust the **POWER slider** to **RADIO**.
→ FM is displayed briefly and then the radio station frequency, waveband and, if programmed, a preset number are shown. (See [3])
2. Press **BAND** once or more to select your waveband.
3. Press and hold **SEARCH** ◀◀ or ▶▶ until the frequency in the display starts running.
→ The radio automatically tunes to a station of sufficient reception. Display shows SRCH during automatic tuning.
4. Repeat step 3 if necessary until you find the desired station.

To tune to a weak station, press ◀◀ or ▶▶ briefly and repeatedly until you have found optimal reception.

To improve radio reception:

- For **FM**, extend, incline and turn the telescopic antenna. Reduce its length if the signal is too strong.
- For **AM**, the set uses a built-in antenna. Direct this antenna by turning the whole set.

Programming radio stations

You can store up to a total of 40 radio stations in the memory, manually or automatically (Autostore).

Manual programming

1. Tune to your desired station (see Tuning to radio stations).
2. Press **PROGRAM** to activate programming.
→ Display: PR -- and **PROG** flashes.
3. Use the digit panel on the set to key in a number, 1-40, to select a preset station. E.g. press 1,1 if you want to store your station as preset 11. (See [4])
- **Remote control (AZ1505 models only):** Press **PRESET + / -** once or more to select a preset station.
4. Press **PROGRAM** to confirm.
5. Repeat steps 1-4 to store other stations.

Note : You can erase a preset station by storing another frequency in its place.

Autostore

Autostore automatically starts programming radio stations from preset 1. Available stations are programmed in order of waveband reception strength: FM, followed by AM. Any previous presets e.g. manually programmed will be erased.

- Press **PROGRAM** for 4 seconds or more to activate autostore programming.
 - The display shows *RLT*, **PROG** blinks, followed by the radio station details when stored.

After all stations are stored, the first preset station will then automatically play.

To listen to a preset station

- Direct Easy Access: use the digit panel on the set to key in a number, 1-40, to select a preset station.
- Remote control (**AZ1505** models only): optionally, press **PRESET +**, **-** to select your preset station.

CD PLAYER

Playing a CD

This CD player plays Audio Discs including CD-Recordables and CD-Rewritables.

1. Adjust the **POWER slider** to **CD**.
2. Insert a CD with the printed side facing up and close the door.
 - *no CD* if no CD inserted/ CD dirty, incorrectly inserted or damaged.
 - *no FCD* if you have inserted a non-finalized CD-R(W).
3. Press **▶II** to start playback.
 - *dRtR* if your CD contains non-audio i.e. data files.
4. To pause playback press **▶II**. Press **▶II** again to resume play.
 - Display: **▶** flashes during pause.
5. To stop CD playback, press the **■** button.

Note : CD play will also stop when:

- the CD-tape door is opened
- the CD has reached the end
- you select **TAPE** or **RADIO** function.

Selecting a different track

There are 2 ways:

Direct Easy Access

- Key in the number of the track using the digit panel on the set.

SEARCH ◀◀ or ▶▶

- Press **SEARCH** ◀◀ or ▶▶ once or repeatedly to select your track.

Finding a passage within a track

1. Press and hold **SEARCH** ◀◀ or ▶▶.
 - The CD is played at high speed and low volume.
2. When you recognize the passage you want, release ◀◀ or ▶▶ to resume normal playback.

Note : During a CD program or if **SHUFFLE/ REPEAT** active, searching is only possible within a track.

Different play modes: SHUFFLE and REPEAT

You can select and change the various play modes before or during playback, and combine the modes with PROGRAM. (See [5])

SHUFFLE - tracks of the entire CD/ program are played in random order

SHUFFLE REPEAT ALL - to repeat the entire CD/ program continuously in random order

REPEAT ALL - repeats the entire CD/ program

REPEAT - plays the current track continuously

1. To select play mode, press **MODE** once or more.
2. Press **▶II** to start playback if in the stop position.
3. To select normal playback, press **MODE** repeatedly until the various modes are no longer displayed.
 - You can also press the **■** button to cancel your play mode.

Programming track numbers

In the stop position, select and store your CD tracks in the desired sequence. Up to 20 tracks can be stored in the memory.

1. Press **SEARCH** ◀◀ or ▶▶ on the set to select your desired track number.
2. Press **PROGRAM**.
 - Display: **PROG, PR** and your selected track number. (See [6])
 - If you attempt to program without first selecting a track number, *no SE* is shown.

CD PLAYER

3. Repeat steps 1-2 to select and store all desired tracks.

→ Display: *FULL* if you try to program more than 20 tracks.

Reviewing the program

In the stop position, press and hold **PROGRAM** until the display shows all your stored track numbers in sequence.

Erasing a program

You can erase the program by:

- pressing **■** twice
→ *ELL* is displayed briefly and **PROG** disappears.
- You select **TAPE** or **RADIO** function.

CASSETTE RECORDER

Cassette playback

1. Adjust the **POWER slider** to **TAPE**.
2. Insert a cassette as shown and close the door.
3. Press **▶** to start playback.
→ Display: shows *TRPE* throughout tape operation.
4. To pause playback press **PAUSE II**. Press again to resume.
5. Press **SEARCH ◀◀** or **▶▶** to fast wind the tape.
6. To stop the tape, press **STOP ■**.

The keys are automatically released at the end of a tape and the set switched off, except if **PAUSE II** has been activated.

General information on recording

- Recording is permissible insofar as copyright or other rights of third parties are not infringed.
- For recording, use only NORMAL type cassettes (IEC type I) on which the tabs have not yet been broken. This deck is not suited for recording on CHROME (IEC II) or METAL (IEC IV) type cassettes.
- The best recording level is set automatically. Altering the **VOLUME** or **DBB** controls will not affect the recording.

CASSETTE RECORDER

- To protect a tape from accidental erasure, break out the tabs. If you wish to record again, cover the tabs with a piece of adhesive tape.

CD Synchro Start Recording

1. Adjust the **POWER slider** to **CD**.
 2. Insert a CD and if desired, program track numbers.
 3. Insert a suitable tape into the cassette deck and close the door.
 4. Press **RECORD ●** to start recording.
– Playing of the CD program starts automatically from the beginning of the program. You don't need to start the CD player separately.
→ To select and record a particular passage within a CD track:
 - Press **SEARCH ◀◀** or **▶▶**. Release the control when you recognize the passage you want.
 - To pause CD playback, press **▶II**.
 - Recording starts from this exact point in the track when you press **RECORD ●**.
 5. To pause recording, press **PAUSE II**. Press **PAUSE II** again to resume recording.
 6. To stop recording, press **STOP ■**.
- ### Recording from the Radio
1. Tune to the desired radio station (see **Tuning to radio stations**).
 2. Follow steps 3-6, under **CD Synchro Start Recording**.

CASSETTE RECORDER

SAFETY AND MAINTENANCE

SAFETY & MAINTENANCE INFORMATION

(See 8)

- Don't expose the set, batteries, CDs or cassettes to humidity, rain, sand or excessive heat.
- Clean the set with a dry cloth. Don't use any cleaning agents containing alcohol, ammonia, benzene or abrasives as these may harm the set.
- Place the set on a hard and flat surface so that the system does not tilt. Make sure there is good ventilation to prevent the set overheating.
- The mechanical parts of the set contain self-lubricating bearings and must not be oiled or lubricated.

CD player and CD handling

- If the CD player cannot read CDs correctly, use a cleaning CD to clean the lens before taking the set to repair.
- The lens of the CD player should never be touched!
- Sudden changes in the surrounding temperature can cause condensation on the lens of your CD player. Playing a CD is then not possible. Do not attempt to clean the lens but leave the set in a warm environment until the moisture evaporates.
- Always close the CD-tape door to avoid dust on the lens.

- To clean the CD, wipe in a straight line from the center towards the edge using a soft, lint-free cloth. Do not use cleaning agents as they may damage the disc.
- Never write on a CD or attach any stickers to it.

Tape deck maintenance

To ensure quality recording and playback of the tape deck, clean parts (A), (B) and (C) as shown, once a month. Use a cotton bud slightly moistened with alcohol or a special head cleaning fluid to clean the deck.

1. Open the CD-tape door.
2. Press **PLAY** ► and clean the roller (C).
3. Press **PAUSE** II and clean the heads (A), and the capstan (B).
4. After cleaning, press **STOP** ■.

Environmental information

We have done our best to reduce the packaging and make it easy to separate into 3 materials: cardboard, expandable polystyrene, polyethylene.

Your set consists of materials which can be recycled if disassembled by a specialized company. Please observe the local regulations regarding the disposal of packaging, head batteries and other equipment.

TROUBLESHOOTING

If a fault occurs, first check the points listed below before taking the set for repair.

If you are unable to remedy a problem by following these hints, consult your dealer or service centre.

WARNING: *Do not open the set as there is a risk of electric shock. Under no circumstances should you try to repair the set yourself, as this will invalidate the warranty.*

No sound /power

- *Volume not adjusted*
- Adjust the VOLUME
- *Power cord not securely connected*
- Connect the AC power cord properly
- *Batteries dead/ incorrectly inserted*
- Insert (fresh) batteries correctly
- *Headphones connected to the set*
- Disconnect headphones

Severe radio hum or noise

- *Electrical interference: set too close to TV, VCR or computer*
- Move the set to increase the distance

Poor radio reception

- *Weak radio signal*
- FM: Adjust the FM telescopic aerial

ⓂⓅⓇ indication

- *During programming radio preset stations, you have keyed in a preset number that exceeds the maximum preset number i.e. 40*
- Key in a preset number from 1-40

ⓂⓅⓈ indication

- *CD badly scratched or dirty*
- Replace/ clean CD, see Maintenance
- *Laser lens steamed up*
- Wait until lens has cleared

ⓂⓇⓈ indication

- *CD-R(W) is blank/ not finalized*
- Use a finalized CD-R(W)

ⓂⓇⓈ indication

- *CD contains non-audio files*
- Press **SEARCH** ◀◀ or ▶▶ once or more to skip to a CD audio track, instead of the data file

The CD skips tracks

- *CD damaged or dirty*
- Replace or clean CD
- *SHUFFLE or PROGRAM is active*
- Switch off SHUFFLE / PROGRAM

Poor cassette sound quality

- *Dust and dirt on the heads, etc.*
- Clean deck parts, see Maintenance
- *Use of incompatible cassette types (METAL or CHROME)*
- Only use NORMAL (IEC I) for recording

Recording does not work

- *Cassette tab(s) may be broken*
- Apply adhesive tape over the missing tab space

Remote control does not function properly (for AZ1505 model only)

- *Batteries dead/ incorrectly inserted*
- Insert (fresh) batteries correctly
- *Distance/ angle between the set too large*
- Reduce the distance/ angle

Free Manuals Download Website

<http://myh66.com>

<http://usermanuals.us>

<http://www.somanuals.com>

<http://www.4manuals.cc>

<http://www.manual-lib.com>

<http://www.404manual.com>

<http://www.luxmanual.com>

<http://aubethermostatmanual.com>

Golf course search by state

<http://golfingnear.com>

Email search by domain

<http://emailbydomain.com>

Auto manuals search

<http://auto.somanuals.com>

TV manuals search

<http://tv.somanuals.com>