

CD Soundmachine

AZ1021
AZ1021C
AZ1021N

Register your product and get support at
www.philips.com/welcome

User Manual



PHILIPS

Download from Www.Somanuals.com. All Manuals Search And Download.

1

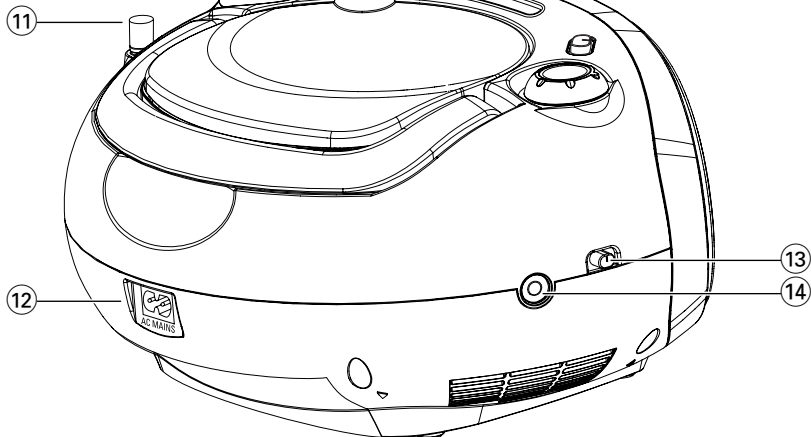
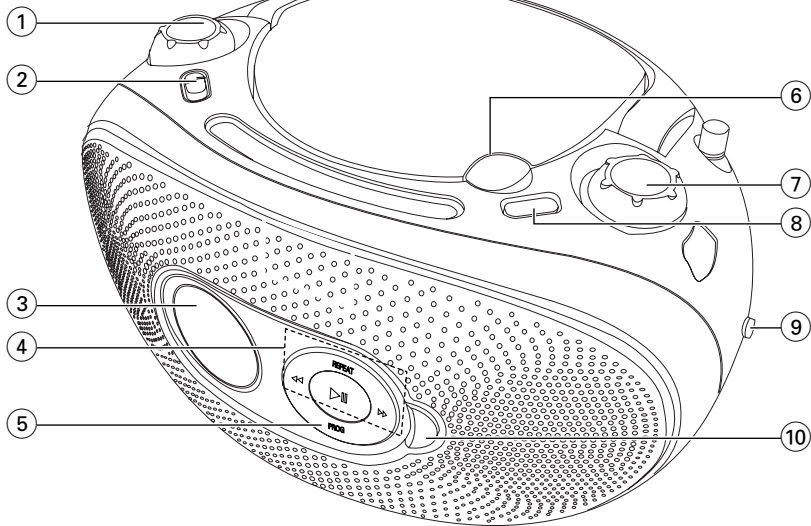

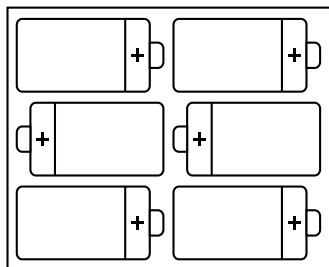

6 x R14 · UM-2 · C-CELLS

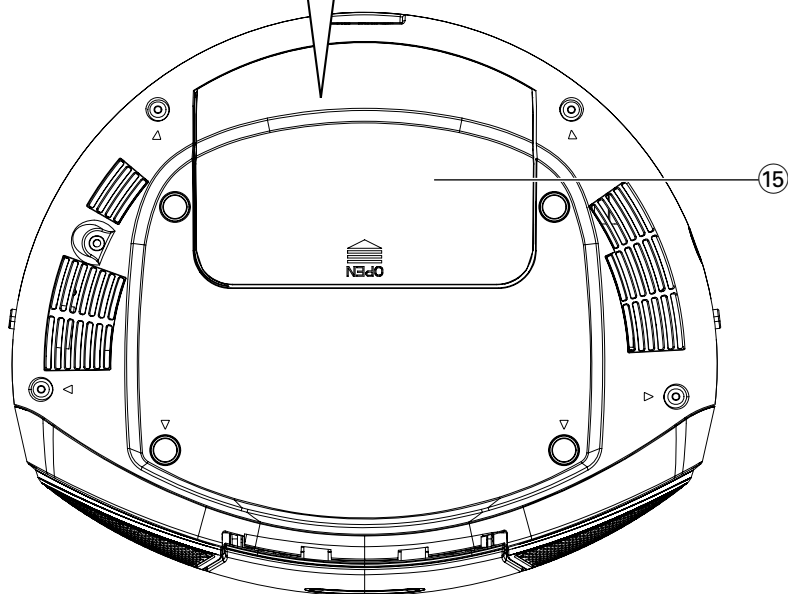

3



8



4

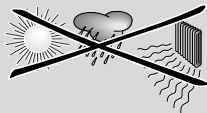

5

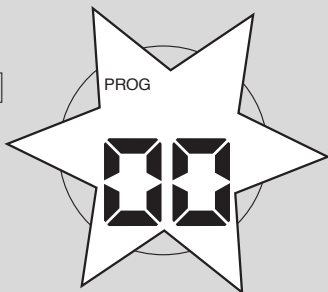

6

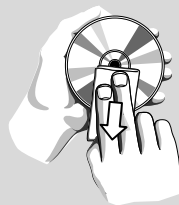

7



Supplied Accessories

- Australian power cord
- VDE power cord

Top/front panels (See 1)

- VOLUME** – adjusts volume level.
 - Source selector: CD, TUNER, OFF**
 - selects CD or radio source of sound
 - power off switch
 - Display** – shows the CD functions
 - ▶ II** – starts or pauses CD playback
▶▶ ◀◀
 - selects the next/previous track
 - searches forward/backward (press and hold the button) within the current track
- REPEAT** – repeats a track/
CD program/entire CD.
- PROG** – programs tracks and reviews the program
 - LIFT TO OPEN** – opens/closes the CD door.
 - TUNING** – tunes to radio stations
 - SHUFFLE** – plays all tracks in random order
 - BAND** – selects waveband
 - STOP** – stops CD playback;
– erases a CD program

Back/bottom panel (See 2 and 3)

- Telescopic antenna** - improves FM reception.
- AC MAINS~** - inlet for power cord.
- DBB** – turns the bass enhancement on/off.
- 🎧** – 3.5 mm stereo headphone socket

Helpful hints:

The speaker is muted when you connect headphones to the set.

Battery door – open to insert 6 x 1.5V R-14/ UM-2/ C-cells

CAUTION

- **Visible and invisible laser radiation. If the cover is open, do not look at the beam.**

- **High voltage! Do not open. You run the risk of getting an electric shock. The machine does not contain any user-serviceable parts.**

- **Modification of the product could result in hazardous radiation of EMC or other unsafe operation.**

Power Supply

Whenever convenient, use the power supply cord if you want to conserve battery life. Make sure you remove the plug from the set and wall outlet before inserting batteries.

Batteries (not included)

- Open the battery door and insert 6 batteries, type **R-14, UM-2** or **C-cells**, (preferably alkaline) with the correct polarity as indicated by the "+" and "-" symbols inside the compartment. (See 2)
- Replace the battery door, making sure the batteries are firmly and correctly in place. The set is now ready to operate.

Batteries contain chemical substances, so they should be disposed of properly.

- Incorrect use of batteries can cause electrolyte leakage and corrode the compartment or cause the batteries to burst:*
- Do not mix battery types: e.g. alkaline with carbon zinc. Only use batteries of the same type for the set.*
- When inserting new batteries, do not try to mix old batteries with the new ones.*
- Remove the batteries if the set is not to be used for a long time.*

Using AC power

WARNING: Always ensure that you have completely switched off the set, before you change or disconnect power supply.

- 1 Check if the power voltage, as shown on the type plate located on the bottom of the set, corresponds to your local power supply. If it does not, consult your dealer or service center.
 - 2 Connect the power cord to the **AC MAINS~** inlet and the wall socket. The set is now connected and ready for use.
 - 3 To switch the set off completely, withdraw the power cord from the wall socket.
 - 4 Install the unit near the AC outlet and where the AC power plug can be easily reached.
- Disconnect the power cord from the wall socket to protect your set during heavy thunderstorms. Children could seriously injure themselves as the free end of the cable may still be live if only the connector is removed from the MAINS socket at the back of the unit.

The type plate is located on the bottom of the set.

Helpful hints:

- To avoid unnecessary energy consumption, always adjust the **Source selector** to **OFF** after using the set.

General operation

Switching on and off and selecting the function

- 1 To select your sound source, adjust the **Source selector** to: **CD**, or **TUNER**.
- 2 To switch off the set, adjust the **Source selector** to **OFF** position.

Adjusting volume and sound

- 1 Adjust volume by using the **VOLUME** control.
- 2 Adjust sound effect by using the **DBB** control.

Radio reception

- 1 Adjust the **Source selector** to **TUNER**.
- 2 Adjust **BAND** to select your desired waveband, **MW** or **FM**.
- 3 Turn **TUNING** to tune to a station.

Helpful hints:

To improve radio reception

- For **FM**, extend, incline and turn the telescopic antenna for best reception and reduce its length if the signal is too strong.
- For **MW**, the set uses a built-in antenna. Direct this antenna for best reception by turning the whole set.

CD Player

Playing a CD

- This CD player plays Audio Discs including CD-Recordables (CD-R) and CD-Rewritables (CD-RW).
- MP3, CD-ROM, CD-I, CDV, VCD, DVD or computer CDs are not possible for playback.

IMPORTANT!

CDs encoded with **copyright protection technologies** by some record companies may be unplayable by this product.

- 1 Adjust the **Source selector** to **CD**.
- 2 Open the CD door, and insert a CD with the printed side facing up, then press the CD door gently to close.
 - Display shows - -, and later the total number of tracks. (See [3])
- 3 Press ►|| to start playback.
- 4 To pause playback, press ►||.
 - Display: ► flashes. (See [4])
- 5 To resume, press ►|| again.
- 6 To stop CD playback, press ■

Helpful hints:

CD play also stops when:

- you open the CD door;
- you select **TUNER** or **OFF** sound source;
- the CD has reached the end.

Selecting a different track

- Press ◀◀/ ▶▶ once or repeatedly until the desired track number appears in the display.
- In the pause/stop position, press ►|| to start playback.

Finding a passage within a track

- 1 During playback, press and hold ◀◀ or ▶▶.
 - The CD is played at high speed and with reduced volume.
- 2 When you recognize the passage you want, release ◀◀ or ▶▶ to resume normal playback.



Helpful hints:

- When your searching reaches the end of the last track, the CD goes to stop mode.

CD Player

Programming track numbers

You may store up to 20 tracks in the desired sequence. If you like, store any track more than once.

- 1 In the stop position, press **PROG** to activate programming.
→ Display: **PROG** and  flash. (See [5](#))
- 2 Press **◀** or **▶** to select your desired track number.
- 3 Press **PROG** to store the desired track number.
→ Display: **PROG** and  flash for you to program the next track.
- 4 Repeat steps **2** to **3** to select and store all desired tracks in this way.
→ If you attempt to store more than 20 tracks, no track can be selected and the display shows --.
- 5 To play your program, press **▶/II**

Helpful hints :

- **When playback of your program comes to the stop position, your set returns to normal playback. To re-enter program mode, press PROG in the stop position.**

Reviewing the program

In the stop position, press **PROG** repeatedly to see your stored tracks.

Erasing a program

You can erase the contents of the memory by:

- in the stop position, press **PROG** to enter program mode, and then press **■**.
- selecting **TUNER** or **OFF**;
- opening the CD door;

Different play modes: REPEAT and SHUFFLE (See [6](#), [7](#))

REPEAT

You can play the current track or the whole disc repeatedly, and combine **REPEAT** modes with **PROG** (PROGRAM).

REP – plays the current track continuously.

REP ALL – repeats the entire CD/program

- 1 To select play mode, press **REPEAT** once or more.
→ The display shows **REP** icon or **REP ALL** icon.
- 2 Press **▶II** to start playback in the stop/pause position.
- 3 To return to normal playback, press **REPEAT** repeatedly until the modes are no longer displayed.
– You can also press **■** to cancel your play mode.

SHUFFLE

You can play all the tracks in random order:

- 1 In the stop position, press **SHUFFLE** to switch on shuffle play.
→ Display shows **SHUF** icon.
- 2 To switch off shuffle play, press **■**.

Helpful hints:

- *During the shuffle play, when **REP** function is selected, the set plays the current shuffled track repeatedly, or when the **REP ALL** function is selected, it repeats the shuffle play of the entire CD.*

CD player and CD handling

- If the CD player cannot read CDs correctly, use a cleaning CD to clean the lens before taking the set to repair.
- Never touch the lens of the CD player!
- Sudden changes in the surrounding temperature can cause condensation on the lens of your CD player. Playing a CD is then not possible. Do not attempt to clean the lens but leave the set in a warm environment until the moisture evaporates.
- Always close the CD door to avoid dust on the lens.
- To clean the CD, wipe in a straight line from the center towards the edge using a soft, lint-free cloth. Do not use cleaning agents as they may damage the disc.
- Never write on a CD or attach any stickers to it.

Safety information

- Place the set on a flat, hard and stable surface so that the system does not tilt.
- Where the MAINS plug or an appliance coupler is used as the disconnect device, the disconnect device shall remain readily operable.
- Do not expose the set, batteries, CDs to humidity, rain, sand or excessive heat caused by heating equipment or direct sunlight.
- The apparatus shall not be exposed to dripping or splashing.
- Adequate ventilation with a minimum gap of 15cm (6 inches) between the ventilation holes and surrounding surfaces is necessary to prevent heat build-up.
- Do not cover the ventilation openings with items such as newspapers, table-cloths, curtains, etc.
- No objects filled with liquids, such as vases, shall be placed on the apparatus.
- No naked flame sources, such as lighted candles, should be placed on the apparatus.
- The mechanical parts of the set contain self-lubricating bearings and must not be oiled or lubricated.
- To clean the set, use a dry cloth. Do not use any cleaning agents containing alcohol, ammonia, benzene or abrasives as these may harm the housing.

Troubleshooting

If a fault occurs, first check the points listed below before taking the set for repair.

If you are unable to remedy a problem by following these hints, consult your dealer or service centre.

WARNING: *Do not open the set as there is a risk of electric shock. Under no circumstances should you try to repair the set yourself, as this will invalidate the guarantee.*

Problem

- Possible cause
- Remedy

No sound /power

- Volume not adjusted
- Adjust the **VOLUME**
- Power cord not securely connected
- Connect the AC power cord properly
- Batteries dead/ incorrectly inserted
- Insert (fresh) batteries correctly
- Headphones connected to the set
- Disconnect headphones.
- CD contains non-audio files
- Press **◀▶** once or more to skip to a CD audio track, instead of the data file.

Display does not function properly / No reaction to operation of any of the controls

- Electrostatic discharge
- Switch off and unplug the set. Reconnect after a few seconds

- -, E r or 0 / indication

- No CD inserted
- Insert a CD
- CD badly scratched or dirty
- Replace/clean CD, see **Maintenance**
- Laser lens steamed up
- Wait until lens has cleared
- CD-R/CD-RW is blank or not finalized
- Use a finalized CD-R/CD-RW or suitable CD Audio disc only

Note:

Make sure the CD is not encoded with copy-right protection technologies, as some do not conform to the Compact Disc standard.

The CD skips tracks

- CD damaged or dirty
- Replace or clean CD
- Program/shuffle is active
- Exit program/shuffle mode

Note: A CD badly scratch or dirty may result in improper operation.

AUSTRALIA - Philips Manufacturers Warranty for Australia only

These warranty conditions are valid for the following consumer electronics products: Colour Televisions, Projection TV, Plasma & LCD TV, Video Cassette Recorders, CD Recorders & Players, DVD Players, DVD Recorders, DVD Recorders with HDD, Audio Systems, Home Theatre systems, Digital Set Top Box & Portable Audio products.

The benefits given to the purchaser by this warranty are in addition to all other rights and remedies which the purchaser has in respect of the product under the Trade Practices Act or other Commonwealth or State Law.

Philips Consumer Electronics warrants its products to the purchaser as follows and subject to the stated conditions.

1 Year Free Repair Service - at Philips ASC

Colour Television, Plasma Television, LCD Television, Projection Television, DVDR/VCR Combo, DVD Recorders with Hard Drive, LCD Projectors, Wireless Audio Systems, Audio Systems, Home Theatre Systems & Digital Set-Top-Box.

1 Year free Replacement – at your Retailer

Portable Audio, MP3 Infotainment products, Video Cassette recorders, DVD Player, DVD/VCR Combo Player, DVD Recorder without HDD & Portable DVD/LCD players.

Conditions of Repair Warranty

1. All claims for warranty service should be made to your nearest Philips Authorised Service Centre or the Philips Technology Care Centre. Reasonable evidence of date of purchase must be provided.
2. This warranty extends only to defects in material or workmanship occurring under normal use of the product when operated in accordance with the instructions.
3. If a replacement product is supplied under the repair policy it is warranted, under this warranty, for the remainder of the warranty of the original purchased product only.
4. Home service is provided only within the normal service area of one of our recommended Authorised Service Centres (ASC). It will be provided for television receivers only with a screen size of 67cms or above (product includes CRT, LCD TV, PTV, and Plasma TV). Televisions with screen size less than 67cms and all other products types are to be taken or sent by the consumer to the workshop of your nearest Authorised Service Centre, at the Consumer's expense.
5. This Manufacturers Warranty is limited to 3 months for the above listed Consumer Electronics products if used in commercial applications.
6. Philips may, at its discretion choose to replace rather than repair any product covered by this warranty.
7. Product accessories are covered by the same warranty period. Please contact the Philips Technology

Care Centre for free replacement of faulty accessories.

8. This Manufacturers Warranty is neither transferable nor valid in countries other than Australia.

This warranty does not cover:

- a) Mileage or travel outside the normal service area covered by selected Authorised Service Centre.
- b) Service costs arising from failure to correctly adjust the controls of the product or to observe the instructions, or inspections that reveal that the product is in normal working order.
- c) Product failures caused by misuse, neglect, accidental breakage, transit damage, inexperienced repairs or modification by un-authorised persons, external fires, lightning strikes, floods, vermin infestation or liquid spillage.
- d) Cleaning of video or audio heads.
- e) Inadequate receiving antennae.
- f) Replacement of worn or used batteries or other consumables.
- g) Consumer products used in commercial applications (This warranty is limited to 3 months only).
- h) Second hand products.

The conditions contained in this warranty card replace and override the provision of the Philips World-Wide Guarantee for products purchased in Australia and used in Australia.

Service is provided through more than 100 accredited Authorised Service Centres throughout Australia. For direct contact with the nearest recommended Authorised Service Centre in capital & regional cities/towns

Authorised Service Centre Network

1300 361 392

Customer support is provided in Australia by our trained call centre staff. For assistance with product features and specifications, please call

Technology Care Centre

1300 363 391

Please record the following information for your records and keep in a safe place. We recommend retaining your purchase receipt to assist with any warranty claim.

Model number:.....

Serial number:.....

Date of purchase:.....

Retailer:.....

Philips Consumer Electronics

a division of **Philips Electronics Australia Limited**
ABN 24 008 445 743,
Level 1, 65 Epping Road NORTH RYDE NSW 2113.

Warranty valid for all new products purchased after **1st January 2007**

Download from Www.Somanuals.com. All Manuals Search And Download.

NEW ZEALAND - Guarantee and Service for New Zealand

Thank-you for purchasing this quality Philips product.

Philips New Zealand Ltd guarantees this product against defective components and faulty workmanship for a period of 12 months. Any defect in materials or workmanship occurring within 12 months from the date of purchase subject to the following conditions will be rectified free of charge by the retailer from whom this product was purchased.

Conditions

- 1.** The product must have been purchased in New Zealand. As proof of purchase, retain the original sales docket indicating the date of purchase.
- 2.** The guarantee applies only to faults caused by defective components, or faulty workmanship on the part of the manufacturer.
- 3.** The guarantee does not cover failures caused by misuse, neglect, normal wear and tear, accidental breakage, use on the incorrect voltage, use contrary to operating instructions, or unauthorised modification to the product or repair by an unauthorised technician.
- 4.** Reasonable evidence (in the form of a sales docket) must be supplied to indicate that the product was purchased no more than 12 months prior to the date of your claim.
- 5.** In the event of a failure, Philips shall be under no liability for any injury, or any loss or damage caused to property or products other than the product under guarantee.

This guarantee does not prejudice your rights under common law and statute, and is in addition to the normal responsibilities of the retailer and Philips.

How to claim

Should your Philips product fail within the guarantee period, please return it to the retailer from whom it was purchased. In most cases the retailer will be able to satisfactorily repair or replace the product.

However, should the retailer not be able to conclude the matter satisfactorily, or if you have other difficulties claiming under this guarantee, please contact

The Guarantee Controller
Philips New Zealand Ltd.

✉ **P.O. Box 41.021**

Auckland

☎ **(09) 84 94 160**

fax ☎ **(09) 84 97 858**

Meet Philips at the Internet

<http://www.philips.com>

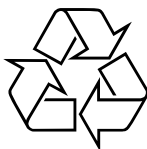

AZ1021
AZ1021N
AZ1021C

**CLASS 1
LASER PRODUCT**



Printed in China

PDCC-ZH-0736

Download from [Www.Somanuals.com](http://www.Somanuals.com). All Manuals Search And Download.

Free Manuals Download Website

<http://myh66.com>

<http://usermanuals.us>

<http://www.somanuals.com>

<http://www.4manuals.cc>

<http://www.manual-lib.com>

<http://www.404manual.com>

<http://www.luxmanual.com>

<http://aubethermostatmanual.com>

Golf course search by state

<http://golfingnear.com>

Email search by domain

<http://emailbydomain.com>

Auto manuals search

<http://auto.somanuals.com>

TV manuals search

<http://tv.somanuals.com>