

PHILIPS

MMS 306/A 3.600 Acoustic Surround Power



5.1 channel Soft Flat Panel speaker system

Instructions for use
Mode d'emploi
Bedienungsanleitung
Istruzioni per l'uso
Manual del Usuario
Installationsanleitung
Brugsanvisning
Käyttöohje
Zalecenia dla użytkownika
使用説明書
Kullanım Kılavuzu
Руководство по эксплуатации
Instrukcja obsługi
Bruksanvisning



PHILIPS

SAFETY INSTRUCTIONS:

For US/Canada only

IMPORTANT SAFETY INSTRUCTIONS - Read before operating equipment

This product was designed and manufactured to meet strict quality and safety standards. There are, however, some installation and operation precautions which you should be particularly aware of.

1. **Read these instructions** - All the safety and operating instructions should be read before the appliance is operated.
2. **Keep these instructions** - The safety and operating instructions should be retained for future reference.
3. **Heed all warnings** - All warnings on the appliance and in the operating instructions should be adhered to.
4. **Follow all instructions** - All operating and use instructions should be followed.
5. **Do not use this apparatus near water** - for example, near a bathtub, washbowl, kitchen sink, laundry tub, in a wet basement or near a swimming pool, etc.
6. **Clean only with a damp cloth.** The appliance should be cleaned only recommended by the manufacturer.
7. **Install in accordance with the manufacturers instructions. Do not block any of the ventilation openings.** For example, the appliance should not be situated on a bed, sofa, rug, or similar surface or placed in a built-in installation, such as a bookcase or cabinet that may impede the flow of air through the ventilation openings.
8. **Do not install near any heat sources** such as radiators, heat registers, stoves, or other apparatus (including amplifiers) that produce heat.
9. **Do not defeat the safety purpose** of the polarized or grounding-type plug. A polarized plug has two blades with one wider than the other. Match wide blade of plug to wide slot, fully insert. A grounding type plug has two blades and a third grounding prong. The wide blade or the third prong are provided for your safety. If the provided plug does not fit into your outlet, consult an electrician for replacement of the obsolete outlet.

**AC
Polarized Plug**
10. **Protect the power cord** from being walked on or pinched particularly at plugs, convenience receptacles, and the point where they exit from the apparatus.
11. **Only use attachments/accessories** specified by the manufacturer.
12.  **Use only with a cart, stand, tripod, bracket, or table** specified by the manufacturer, or sold with the apparatus. When a cart is used, use caution when moving the cart/apparatus combination to avoid injury from tip-over.
13. **Unplug this apparatus** during lightning storms or when unused for long periods of time.
14. **Refer all servicing** to qualified service personnel. Servicing is required when the apparatus has been damaged in any way, such as power-supply cord or plug is damaged, liquid has been spilled or objects have fallen into the apparatus, the apparatus has been exposed to rain or moisture, does not operate normally, or has been dropped.
15. **Warning!** To reduce the risk of fire or electric shock, do not expose this appliance to rain or moisture.

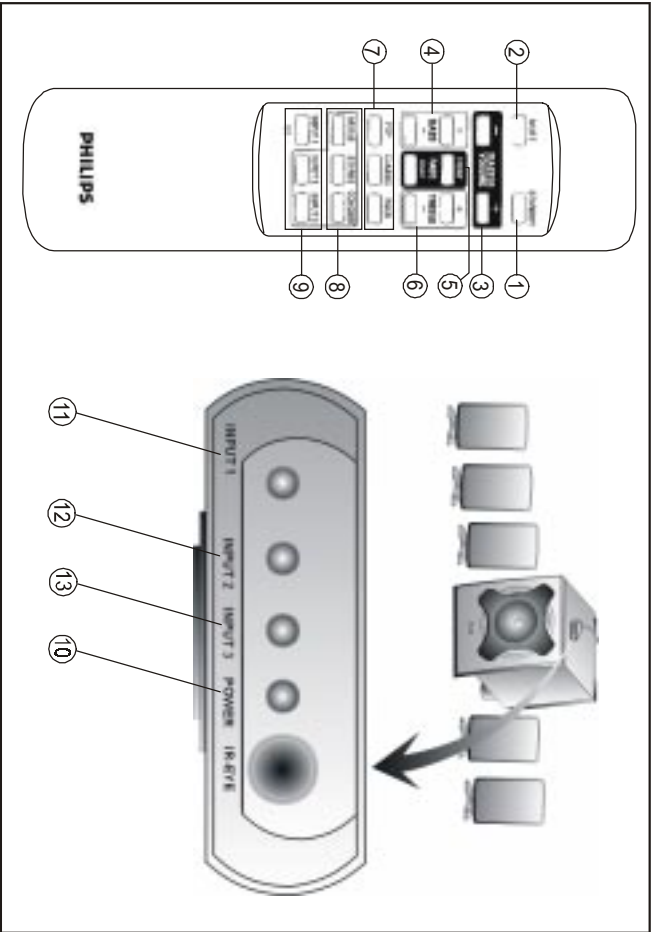

Illustration A

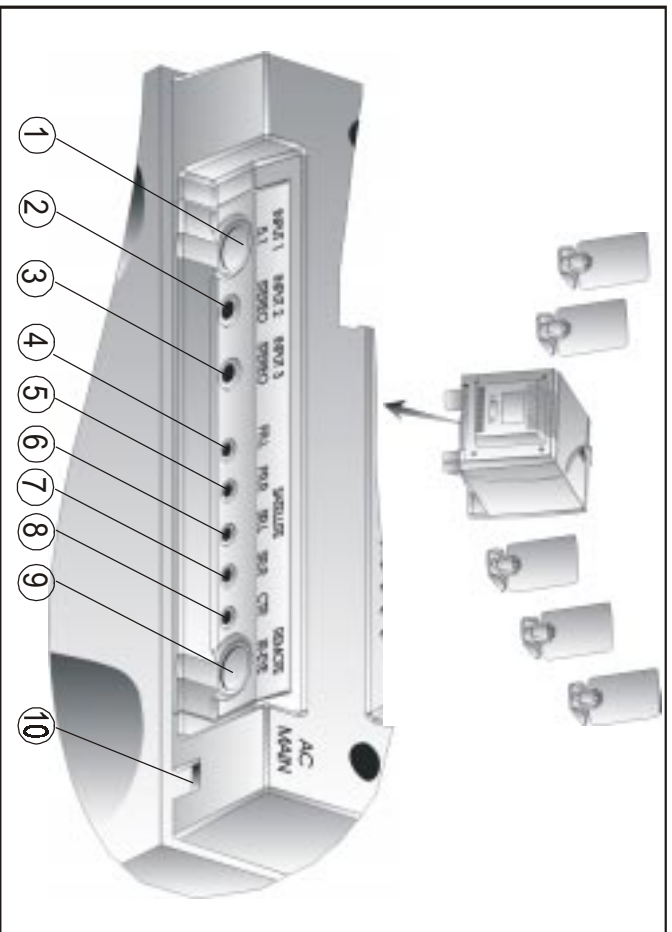

Illustration B

Important notes for users in the U.K.

Mains plug

This apparatus is fitted with an approved 13 Amp plug.

To change a fuse in this type of plug proceed as follows:

- 1 Remove fuse cover and fuse.
- 2 Fix new fuse which should be a BS1362 5 Amp, A.S.T.A. or BSI approved type.
- 3 Refit the fuse cover.

If the fitted plug is not suitable for your socket outlets, it should be cut off and an appropriate plug fitted in its place. If the mains plug contains a fuse, this should have a value of 5 Amp. If a plug without a fuse is used, the fuse at the distribution board should not be greater than 5 Amp.

Note: *The severed plug must be disposed of to avoid a possible shock hazard should it be inserted into a 13 Amp socket elsewhere.*

How to connect a plug

The wires in the mains lead are coloured with the following code: blue = neutral (N), brown = live (L). As these colours may not correspond with the colour markings identifying the terminals in your plug, proceed as follows:

- Connect the blue wire to the terminal marked N or coloured black.
- Connect the brown wire to the terminal marked L or coloured red.
- Do not connect either wire to the earth terminal in the plug, marked E (or \perp) or coloured green (or green and yellow).

Before replacing the plug cover, make certain that the cord grip is clamped over the sheath of the lead - not simply over the two wires.

Copyright in the U.K.

Recording and playback of material may require consent. See Copyright Act 1956 and The Performer's Protection Acts 1958 to 1972.

Norge

Typeskilt finnes på apparatens underside.

Observer: Nettbryteren er sekundert innkoplet. Den innebygde nettdelen er derfor ikke frakoplet nettet så lenge apparatet er tilsluttet nettkontakten.

For å redusere faren for brann eller elektrisk støt, skal apparatet ikke utsettes for regn eller fuktighet.

Deutschland

Hiermit wird bescheinigt, daß dieses Gerät in Übereinstimmung mit den Bestimmungen der Amtsblattverfügung 1046/1984 funktentstört ist.

Der Deutschen Bundespost wurde das Inverkehrbringen dieses Gerätes angezeigt und die Berechtigung zur Überprüfung der Serie auf Einhaltung der Bestimmungen eingeräumt.

English6	English
Français12	Français
Deutsch18	Deutsch
Italiano24	Italiano
Español30	Español
Nederlands ..36	Nederlands
Svenska42	Svenska
Suomi48	Suomi
Polski54	Polski
中文60	中文
Türkçe66	Türkçe
Русский72	Русский
Norsk78	Norsk
Dansk84	Dansk

Description

Ultra-thin design, powerful 5.1 surround audio!

The **A 3.600 Acoustic Surround Power / MMS 306** is the result of the ultimate fusion of Philips acoustical core competencies. We created a 5.1-channel speaker system that features five ultra-thin soft flat panel speakers, a variety of mounting options and an explosive wOOx™ subwoofer. The set is the perfect choice for a space-saving hifi audio solution.

This Soft Flat Panel speaker system is especially designed to be a hifi multimedia 5.1-channel speaker system. All together, there can be connected up to three audio-visual sources at the same time directly to the speaker system. Three keys on the remote control are provided to make your audio device selection:

INPUT 1 → 5.1-channel input

INPUT 2 → stereo input

INPUT 3 → stereo input

This 5.1-channel speaker system will enhance dramatically your gaming and audio-visual experience. It delivers the ultimate sound solution during games and movies by providing thrilling surround sound with an intense bass impact. For optimum performance, the set is best used with 5.1-channel audio inputs.

When connecting stereo audio-visual sources to the set, (INPUT 2 or INPUT 3), built in multi-channel processing algorithms will indulge you sound from all speakers around you.

Ultra thin, stylish design, superb acoustic quality and high impact bass power from all around you!

Philips Advanced Technologies

wOOx™



Anchored by a 50 watt subwoofer, the **A 3.600 Acoustic Surround Power / MMS 306** system employs Philips' patented wOOx™ Bass Driver technology to generate superior bass from a deceptively small enclosure. The wOOx™ bass drivers are composed of a unique dual suspension design mounted in front of the subwoofer resulting in a deeper, richer bass performance you would expect from a larger subwoofer. With the symmetrical construction of the wOOx™ Bass Radiator, there is complete balance of the membrane movement producing no discernable distortion. As a result, gaming and movie effects are more intense and music more enjoyable.

Soft Flat Panel Satellite Speakers



NXT* has developed a unique loudspeaker technology that has redesigned the shape of sound. Philips has taken a new step in optimizing the implementation of NXT's* technology by adding a High Frequency Booster. The High Frequency Booster boosts the sound pressure at higher frequencies, thereby enabling the use of a soft panel material whose sound quality surpasses the performance of many home audio systems.

*NXT Trade Mark of New Transducers Ltd.



Trade Mark of New Transducers Ltd.
All Patent Rights Reserved.

Explanation Remote Control

(See Illustration A, page 3)

Remote Control

- ① **STANDBY**
To switch the speaker system into ON or OFF (=STANDBY) mode
- ② **MUTE**
To switch the speaker system into mute mode, and normal mode again
- ③ **MASTER VOLUME - / +**
To adjust the master volume higher or lower
- ④ **BASS - / +**
To adjust the bass level according your personal preference
- ⑤ **FADE REAR / FRONT**
To adjust the loudness of the rear and the front satellite speakers
- ⑥ **TREBLE - / +**
To adjust the presence of the higher tones according your personal preference
- ⑦ **POP / CLASSIC / ROCK**
Choose from either the POP, CLASSIC or ROCK button for optimal pre-set sound reproduction per genre
- ⑧ **MOVIE / STEREO / CONCERT**
When using a stereo source as input, choose from either the MOVIE, STEREO or CONCERT button for optimal pre-set multi-channel sound processing
- ⑨ **INPUT 1 / INPUT 2 / INPUT 3**
Make your choice of audio-visual source selection. Two separate stereo input sources and one 5.1-channel input source can be connected to this 5.1-channel speaker system

Remote Control Receiver

- ⑩ **POWER (LED)**
The red color indicates that the system is in standby mode.
- ⑪ **INPUT 1 (LED)**
The green color indicates that the system is active and INPUT 1 is selected
- ⑫ **INPUT 2 (LED)**
The green color indicates that the system is active and INPUT 2 is selected
- ⑬ **INPUT 3 (LED)**
The green color indicates that the system is active and INPUT 3 is selected

Note:

Two green LEDs indicate that mute is activated.

Explanation Cable Connections

(See Illustration B, page 3)

Inputs

- ① **INPUT 1: 5.1-channel**
9 pin DIN jack to connect a 5.1-channel audio-visual source
- ② **INPUT 2: stereo channel**
3.5 mm stereo jack to connect a stereo audio-visual source
- ③ **INPUT 3: stereo channel**
3.5 mm stereo jack to connect a stereo audio-visual source

Satellite

- ④ **FRL**
To connect the front left satellite speaker
- ⑤ **FRR**
To connect the front right satellite speaker
- ⑥ **SRL**
To connect the surround left satellite speaker
- ⑦ **SRR**
To connect the surround right satellite speaker
- ⑧ **CTR**
To connect the center satellite speaker

Remote Control

- ⑨ **IR-EYE**
To connect the remote control IR-EYE

Power

- ⑩ **AC-MAIN**
Power cable to be connected to the AC outlet

WALL MOUNTING OPTION

The design of the satellites offers wall mounting as an option

Installation (Illustration page 8)

English

Included Cables

1. 5.1 Audio Cable (DVD version only)
2. 5.1 Channel Soundcard Cable
3. Stereo TV / Audio Source Cable
4. Stereo 3.5 mm Cable

Speaker Connections

1. Connect the front left satellite speaker to FRL
2. Connect the front right satellite speaker to FRR
3. Connect the surround left satellite speaker to SRL
4. Connect the surround right satellite speaker to SRR
5. Connect the center satellite speaker to CTR

Remote Control Connection

6. Connect the Remote Control IR-EYES connector to the REMOTE IR-EYES and place the eye on top of your monitor / desktop PC / TV / other audio-visual source

Signal Source Connections

7. Connections to INPUT 1 (9-pin DIN Connector)
 - (a) Connections from DVD player/ 5.1 audio source:
 - 2 x RCA for front and rear RIGHT satellites (red)
 - 2 x RCA for front and rear LEFT satellites (white)
 - 1 x RCA for CENTER speaker (blue)
 - 1 x RCA for LFE speaker (black)
 - (b) Connections from 5.1 channel soundcard:
 - 1 x 3.5 mm stereo Jack for FRONT satellites (green)
 - 1 x 3.5 mm stereo Jack for REAR satellites (white)
 - 1 x 3.5 mm stereo Jack for LFE/ CENTER speaker (orange)
8. Connections to INPUT 2 and INPUT 3 (3.5 mm stereo Jack)
 - (a) Connections from TV / audio source:
 - 1 x RCA (red)
 - 1 x RCA (white)
 - (b) Connections from CD/ MP3 player:
 - 1 x 3.5 mm stereo Jack (HEADPHONE OUT / LINE OUT)
9. Connect the fixed mains power cord to the AC outlet
10. Switch on (and switch off as well) the system using the STANDBY button on the remote control
11. Tune the system using the controls on the soundcard/ sound source and / or the controls on the remote control

NOTE: Do not insert the power plug into the AC outlet until all connections are made!

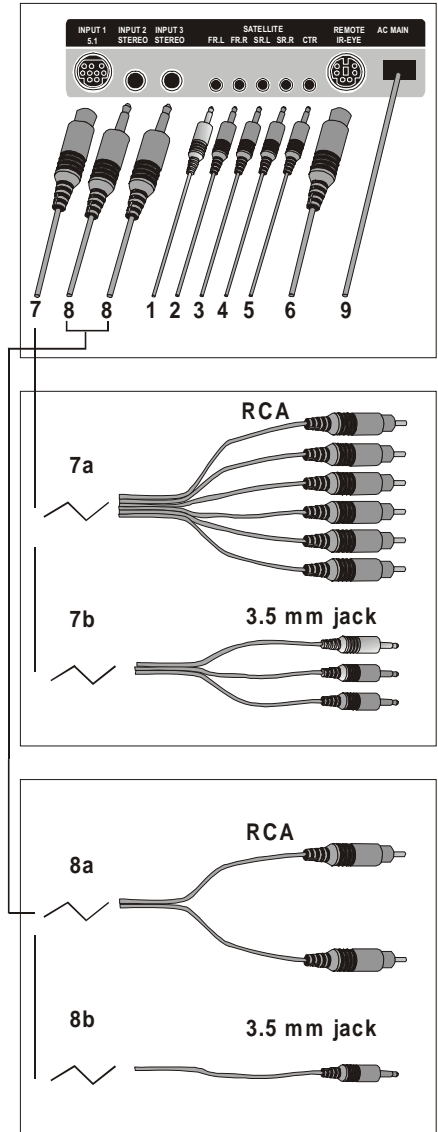

Speaker Placement (Illustration page 9)

General

- Placing speakers behind curtains, furniture, or any other objects will reduce the treble response, thus reducing the stereo effect significantly.
- Each room has different acoustic characteristics and the placement possibilities are often limited. You can find the best position for your speakers by experimenting. In general, the speakers should be placed as symmetrical as possible in the room.

Front Satellite Speakers (figure a)

- The front left and right satellite speaker play stereo music and the off-screen sounds of video playback.
- These satellites should be placed to the sides of your TV or monitor.
- Viewed from the listener's position, the satellite speaker connected to **FL** at the subwoofer should be on the left side, and the satellite speaker connected to **FR** at the subwoofer should be on the right side.
- The best stereo effect is obtained when the two front satellite speakers and the listener form an equilateral triangle.
- The optimum height for these speakers is when they are placed at ear height (while seated).

Center Satellite Speaker (figure b)

- The center satellite speaker provides the on-screen effects and dialog in Dolby Digital / Dolby Surround.
- It should be placed as close to the center of your TV / monitor as possible (e.g. underneath or on top of your TV / monitor).
- It should be directed at the listener's ear level while seated.

Surround Satellite Speakers (figure c)

- The surround left and right satellite speaker provide the surround effects in Dolby Digital / Dolby Surround
- These satellites may be placed in any convenient sites alongside the listener, even sites slightly forward the listener's position.
- The surround satellite speakers do not have to be at exactly the same height as the front satellite speakers.
- Viewed from the listener's position, the satellite speaker connected to **SL** at the subwoofer should be on the left side, and the satellite speaker connected to **SR** at the subwoofer should be on the right side.
- If you have side walls close to your listening position, good placement for your surround satellites is slightly behind your position and slightly above ear level.

Subwoofer (figure d)

- The subwoofer's optimum place is on the floor close to the wall. The closer it is to the corner, the stronger the maximum bass output.
- The subwoofer is not magnetically shielded, so position it at least 0.5 meter from the TV / monitor.

Figure a:

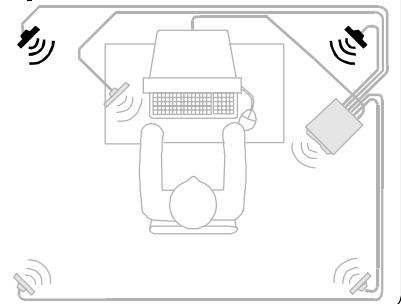

Figure b:

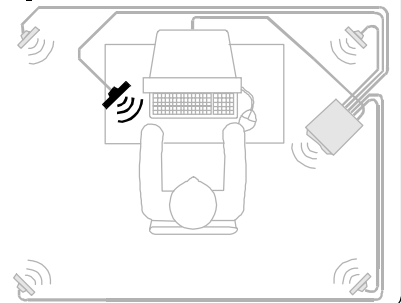

Figure c:

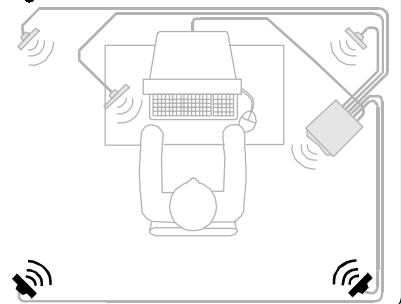
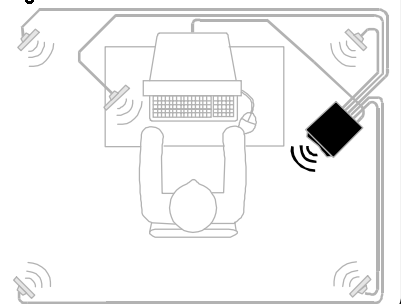

Figure d:



Explanation Sound Presets

Whether your input signal is from a stereo or 5.1 audio-visual source, the set provides you the ability to chose from either the POP, CLASSIC or ROCK modes for optimal preset sound reproduction.

POP

For optimal sound reproduction while listening to modern pop music, emphasizing the high and low frequencies.

CLASSIC

For optimal sound reproduction while listening to classical music, exactly the way classic music is composed to be perceived – pure.

ROCK

For optimal sound reproduction while listening to rock music. Also when you're playing games, this feature adds an absolutely new dimension to your games / music.

Even when the input signal is received from a stereo source only, the speaker system provides three kinds of sound presets for you to chose from to enhance, thus optimize, your listening enjoyment.

MOVIE

Transfers the stereo input signal into a 5.1 channel movie experience. It will give you the impression as if you are in the middle of the scene.

CONCERT

Transfers the stereo input signal into a 5.1 channel concert hall experience. It will give that "live" feeling as if you were present at the concert yourself.

STEREO

Just for those who would like to hear stereo sound in its original way – stereo.

Safety

- Do not expose the speakers to excessive heat (caused by heating equipment or direct sunlight). To reduce the risk of fire or electric shock, do not expose this appliance to rain or moisture. If fluid spills into the speakers, disconnect any connections immediately and let the speakers dry before reusing them.
- You may clean the speakers with a soft, slightly dampened lint-free cloth. Do not use any cleaning agents as they may have a corrosive effect.
- If the speakers do not operate, disconnect them from the power supply. Wait a few seconds before reconnecting them to the power supply.
- If your intentions are not to use the speaker system for a longer period of time - for example, you're going on a vacation - it is recommended to switch off the system completely and not to leave it in standby mode.

Specifications

Overall

- output power : 100 watts RMS
- THD : 10% @ 100 watts RMS
- frequency response : 40 – 20,000 Hz
- cross-over frequency : 200 Hz
- magnetically compensated

Pre-amplifier

- input impedance : > 10k ohms
- clipping level : 2 V RMS
- digital volume : 32 steps @ 1dB per step
- bass : ±9dB @ 1.8dB per step
- treble : ±6dB @ 1.5dB per step

Satellites

- drivers : 8 ohms Soft Flat 3.25"x5.0"
- output power : 5 x 10 watts RMS @ 10% THD
- frequency response : 200 – 20,000 Hz

Subwoofer

- drivers : 5.25" super woofer + 6" woox
- output power : 2 x 25 watts RMS @ 10% THD
- frequency response : 40 – 200 Hz

Remote Control

- # of functions : 19 key buttons

Dimensions

- satellites : 158 (H) x 82 (W) x 81 (D) mm
- subwoofer : 228 (H) x 190 (W) x 266 (D) mm
- remote control : 168 (L) x 38 (W) x 17 (D) mm
- packaging : 284 (H) x 323 (W) x 384 (D) mm

Weight

- satellites : 5 x 0.2 Kg
- subwoofer : 5.12 kg

System Requirements

- preferred : 5.1-channel sound source
- other possibilities : stereo sound source, MP3 / CD / Cassette player, game consoles

Free Manuals Download Website

<http://myh66.com>

<http://usermanuals.us>

<http://www.somanuals.com>

<http://www.4manuals.cc>

<http://www.manual-lib.com>

<http://www.404manual.com>

<http://www.luxmanual.com>

<http://aubethermostatmanual.com>

Golf course search by state

<http://golfingnear.com>

Email search by domain

<http://emailbydomain.com>

Auto manuals search

<http://auto.somanuals.com>

TV manuals search

<http://tv.somanuals.com>