

Time-lapse Video Recorder

Instructions for Use



Eng

D

F

I

E

NL

LTC 3963/51

IMPORTANT SAFEGUARDS

1. Read Instructions — All the safety and operating instructions should be read before the unit is operated.
2. Retain Instructions — The safety and operating instructions should be retained for future reference.
3. Heed Warnings — All warnings on the unit and in the operating instructions should be adhered to.
4. Follow Instructions — All operating and use instructions should be followed.
5. Cleaning — Unplug the unit from the outlet before cleaning. Do not use liquid cleaners or aerosol cleaners. Use a damp cloth for cleaning.
6. Attachments — Do not use attachments not recommended by the product manufacturer as they may cause hazards.
7. Water and Moisture — Do not use this unit near water – for example, near a bath tub, wash bowl, kitchen sink, or laundry tub, in a wet basement, near a swimming pool, in an unprotected outdoor installation, or any area which is classified as a wet location.
8. Accessories — Do not place this unit on an unstable stand, tripod, bracket, or mount. The unit may fall, causing serious injury to a person and serious damage to the unit. Use only with a stand, tripod, bracket, or mount recommended by the manufacturer, or sold with the product. Any mounting of the unit should follow the manufacturer's instructions, and should use a mounting accessory recommended by the manufacturer.

An appliance and cart combination should be moved with care. Quick stops, excessive force, and uneven surfaces may cause the appliance and cart combination to overturn.



9. Ventilation — Openings in the enclosure, if any, are provided for ventilation and to ensure reliable operation of the unit and to protect it from overheating. These openings must not be blocked or covered. This unit should not be placed in a built-in installation unless proper ventilation is provided or the manufacturer's instructions have been adhered to.
10. Power Sources — This unit should be operated only from the type of power source indicated on the marking label. If you are not sure of the type of power supply you plan to use, consult your appliance dealer or local power company. For units intended to operate from battery power, or other sources, refer to the operating instructions.
11. Grounding or Polarization — This unit may be equipped with a polarized alternating-current line plug (a plug having one blade wider than the other). This plug will fit into the power outlet only one way. This is a safety feature. If you are unable to insert the plug fully into the outlet, try reversing the plug. If the plug should still fail to fit, contact your electrician to replace your obsolete outlet. Do not defeat the safety purpose of the polarized plug.

Alternately, this unit may be equipped with a 3-wire grounding-type plug, a plug having a third (grounding) pin. This plug will only fit into a grounding-type power outlet. This is a safety feature. If you are unable to insert the plug into the outlet, contact your electrician to replace your obsolete outlet. Do not defeat the safety purpose of the grounding-type plug.

12. Power-Cord Protection — Power-supply cords should be routed so that they are not likely to be walked on or pinched by items placed upon or against them, paying particular attention to cords and plugs, convenience receptacles, and the point where they exit from the appliance.
13. Power Lines — An outdoor system should not be located in the vicinity of overhead power lines or other electric light or power circuits, or where it can fall into such power lines or circuits. When installing an outdoor system, extreme care should be taken to keep from touching such power lines or circuits as contact with them might be fatal. U.S.A. models only – refer to the National Electrical Code Article 820 regarding installation of CATV systems.
14. Overloading — Do not overload outlets and extension cords as this can result in a risk of fire or electric shock.
15. Object and Liquid Entry — Never push objects of any kind into this unit through openings as they may touch dangerous voltage points or short-out parts that could result in a fire or electric shock. Never spill liquid of any kind on the unit.
16. Servicing — Do not attempt to service this unit yourself as opening or removing covers may expose you to dangerous voltage or other hazards. Refer all servicing to qualified service personnel.

17. Damage Requiring Service — Unplug the unit from the outlet and refer servicing to qualified service personnel under the following conditions.
 - a. When the power-supply cord or plug is damaged.
 - b. If liquid has been spilled, or objects have fallen into the unit.
 - c. If the unit has been exposed to rain or water.
 - d. If the unit does not operate normally by following the operating instructions. Adjust only those controls that are covered by the operating instructions, as an improper adjustment of other controls may result in damage and will often require extensive work by a qualified technician to restore the unit to its normal operation.
 - e. If the unit has been dropped or the cabinet has been damaged.
 - f. When the unit exhibits a distinct change in performance – this indicates a need for service.
18. Replacement Parts — When replacement parts are required, be sure the service technician has used replacement parts specified by the manufacturer or have the same characteristics as the original part. Unauthorized substitutions may result in fire, electric shock or other hazards.
19. Safety Check — Upon completion of any service or repairs to this unit, ask the service technician to perform safety checks to determine that the unit is in proper operating condition.
20. Coax Grounding — If an outside cable system is connected to the unit, be sure the cable system is grounded. U.S.A. models only – Section 810 of the National Electrical Code, ANSI/NFPA No. 70-1981, provides information with respect to proper grounding of the mount and supporting structure, grounding of the coax to a discharge unit, size of grounding conductors, location of discharge unit, connection to grounding electrodes, and requirements for the grounding electrode.
21. Lightning — For added protection of this unit during a lightning storm, or when it is left unattended and unused for long periods of time, unplug it from the wall outlet and disconnect the cable system. This will prevent damage to the unit due to lightning and power-line surges.

As the colours of the wires in the mains lead of this apparatus may not correspond with the coloured markings identifying the terminals in your plug, proceed as follows:

- the wire which is coloured green and yellow must be connected to the terminal in the plug which is marked with the letter E or by the earth symbol , or coloured green or green and yellow.
- the wire which is coloured blue must be connected to the terminal which is marked with the letter N or coloured black.
- the wire which is coloured brown must be connected to the terminal which is marked with the letter L or coloured red.

WARNING — THIS APPARATUS MUST BE EARTHED.

SAFETY PRECAUTIONS

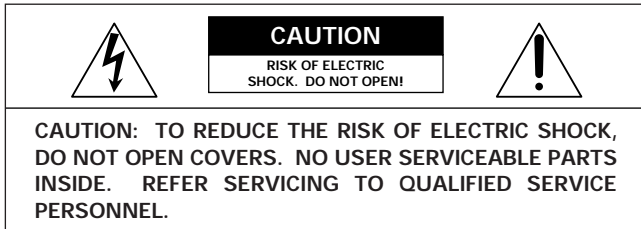

This label may appear on the bottom of the unit due to space limitations.

 The lightning flash with an arrowhead symbol, within an equilateral triangle, is intended to alert the user to the presence of uninsulated "dangerous voltage" within the product's enclosure that may be of sufficient magnitude to constitute a risk of electric shock to persons.

 The exclamation point within an equilateral triangle is intended to alert the user to presence of important operating and maintenance (servicing) instructions in the literature accompanying the appliance.

WARNING

To prevent fire or shock hazard, do not expose units not specifically designed for outdoor use to rain or moisture.

 **Attention:** Installation should be performed by qualified service personnel only in accordance with the National Electrical Code or applicable local codes.

 **Power Disconnect:** Units with or without ON-OFF switches have power supplied to the unit whenever the power cord is inserted into the power source; however, the unit is operational only when the ON-OFF switch is in the ON position. The power cord is the main power disconnect for all units.

 **External Power Supplies**
Use Only the Recommended Power Supplies. Power supplies must comply with the requirements of the latest version of IEC 65/VDE 0860. Substitutions may damage the unit or cause a fire or shock hazard.

220-240 V, 50 Hz Power Cords

 220-240 V, 50 Hz power cords, input and output, must comply with the latest versions of IEC Publication 227 or IEC Publication 245.



WARNING: Electrostatic-sensitive device. Use proper CMOS/MOSFET handling precautions to avoid electrostatic discharge.

NOTE: Grounded wrist straps must be worn and proper ESD safety precautions observed when handling the electrostatic-sensitive printed circuit boards.

1 UNPACKING

Unpack carefully. This is electronic equipment and should be handled carefully.

Check to ensure that the following items are included:

- Model number of unit.

If an item appears to have been damaged in shipment, replace it properly in its carton and notify the shipper. If any items are missing, notify your Philips Communication & Security Systems Inc. Sales Representative or Customer Service.

The shipping carton is the safest container in which the unit may be transported. Save it for possible future use.

2 SERVICE

If the unit ever needs repair service, the customer should contact the nearest Philips Communication & Security Systems Inc. Service Center for return authorization and shipping instructions.

Service Centers

U.S.A. & Canada: 800-366-2283

Mexico & Central America: 52-5-564-2726

Europe & Middle East: 44-1932-765666

South America: 54-1-956-0837

Australia: 61-2-888-9000

New Zealand: 64-4-237-7297

3 DESCRIPTION

4 INSTALLATION

FEATURES

Recording

- HD (High Density) Mode Recording Only
- Eight Touch-Selectable Recording Speeds
- Automatic "Alarm-Command" Speed Up
- Recording Check
- One Shot Recording
- On-Screen and On-Tape Time/Date Information
- 7-Day Programmable On/Off Timer
- "Alarm On" Output
- Usable Audio at 09 and 27 Hour Speeds
- RS-232C Interface Connector

Playback

- Time-of-Alarm Memory and Alarm Index Search
- High Speed Visual Search
- Seven Playback Speeds
- Still Field, Field-Advance, Field-Reverse and Reverse Playback

Security

- About 720 Hours Memory Protection
- Electronic Security Lockout

Note: This recorder has a rechargeable battery to maintain display functions and recording mode within 720 hours in the event of power loss. When the recorder is received, the unit must be connected to power source for 48 hours to assure the battery has been adequately charged.

CONTENTS

IMPORTANT SAFEGUARDS	1
SAFETY PRECAUTIONS	2
PRECAUTIONS	4
CONTROLS AND FUNCTIONS	5
INSTALLATION	9
EXTERNAL CONNECTIONS	10
CASSETTE TAPES	12
SETUP	13
SETTING THE TIME AND DATE	14
SETTING [OPTIONS] ITEMS	15
SUMMER TIME FUNCTION	15
SETTING THE TIMER	15
SETTING THE VCR FUNCTIONS	17
SETTING THE BUZZER.....	18
SETTING THE ALARM.....	19
ALARM MEMORY RECALL AND RESET	20
OPERATION.....	21
TAPE RECORDING.....	21
REC CHECK.....	21
AUTO REC CHECK.....	21
ONE SHOT RECORDING	21
TIMER RECORDING.....	21
TAPE RECYCLE	21
ALARM RECORDING.....	22
MASTER SYSTEM RESET.....	22
PLAYBACK.....	22
STILL PLAYBACK.....	22
V.LOCK ADJUST.....	22
PLAYBACK IN THE FIELD ADVANCE/ REVERSE MODES	23
VISUAL SEARCH (High Speed Scan)	23
ALARM INDEX SEARCH	23
TO SECURE THE VCR	23
OPERATING THE VCR FROM A PERSONAL COMPUTER	24
PROBLEM GUIDE.....	28
SPECIFICATIONS	29

Auto Head Cleaning System

This system cleans the video heads automatically when a cassette is inserted and ejected or the tape is rewound in the recycle recording mode, to prevent dirt from accumulating on the heads.

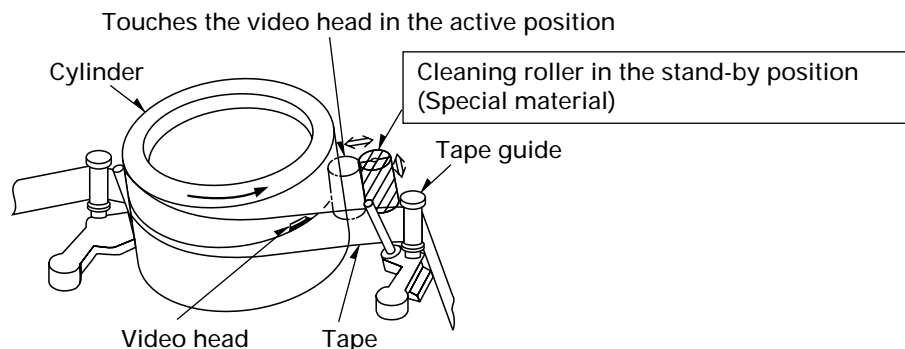

PRECAUTIONS

Safety

- Should any solid object or liquid fall into the cabinet, turn off the unit and have it checked by qualified personnel before operating it any further.
- To disconnect the mains lead, pull it out by the plug. Never pull the lead itself.

Installation

- Choose a location in which air can pass through the ventilation holes in the bottom, top and back of the unit to prevent it from overheating.
- Do not install the unit near heat sources such as radiators or air ducts or in a place subject to direct sunlight, excessive dust, mechanical vibrations or shock.
- Do not place heavy objects or heat-generating objects on the VCR, or the cabinet could be damaged or the temperature inside the VCR could rise, which could cause a fault.
- Never bring a magnet or magnetized object near the VCR because it will adversely affect the performance of the VCR.
- Do not install the unit in an inclined position. The unit is designed for operation in a horizontal position.

Operation

- Condensation
If you pour a cold liquid into a glass, water vapor in the air will condense on the surface of the glass.
This is the condensation of moisture.
Condensation on the head drum, one of the most crucial parts of the VCR, will cause damage to the tape. The VCR should not be operated for at least 2 hours after being moved from a cold to a hot environment to avoid condensation from occurring on the head drum.

Cleaning

- Be careful; when the surface of the case is wiped with a volatile agent such as benzine, alcohol, thinner, etc., or a chemically processed cloth, the surface finish may be degraded or its coating may peel off.

Repacking

- It is wise to save the packing materials and box in case you ever need to ship or store your unit.

CONTROLS AND FUNCTIONS

[FRONT]

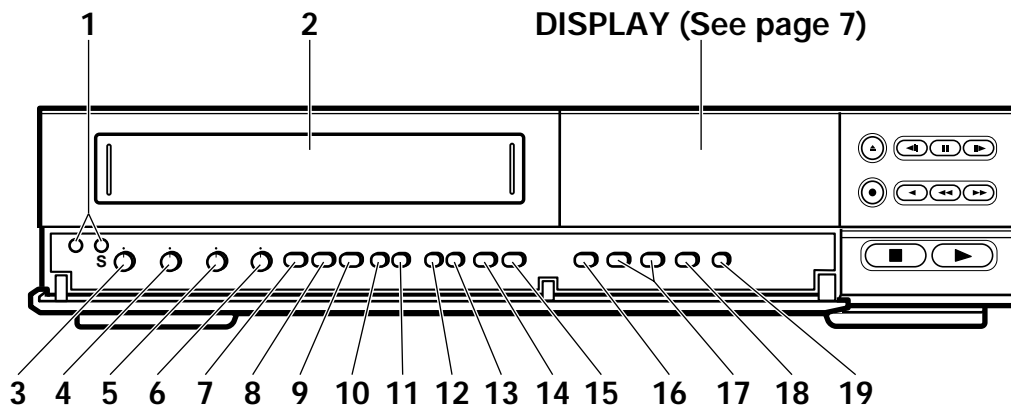

1. RESET BUTTONS

Press these buttons at the same time to clear all (microprocessor) functions.
Press the "S" button to reset the system. (This does not erase the stored information.)

2. CASSETTE COMPARTMENT

3. SHARPNESS CONTROL

Adjust the picture quality to hard or soft during playback.

4. TRACKING CONTROL

Adjust to optimize the picture quality during playback at the 09 and 27 hour speeds.

5. SLOW TRACKING CONTROL

Adjust to optimize the picture quality in the SLOW PLAY mode, e.g. speeds over 48 hours.

6. V. LOCK CONTROL

Reduces vertical jitter in the still play mode.

7. PROGRAM BUTTON

Press to select one of the six programmable functions.

8. START/STOP BUTTON

Press to start or stop the programming of a programmable function. (Press once to start the programming sequence and a second time to stop (end) it.)

9. SET BUTTON

Press to select the specific value which is to be changed with the UP/DOWN buttons.

10. DOWN BUTTON

Press to decrement, change or reverse to the previous/lower value.

11. UP BUTTON

Press to increase, change or advance to the next higher value.

12. V-POS (VERTICAL POSITION) BUTTON

Press repeatedly to control the vertical position of the programmable display on the monitor.

13. H-POS (HORIZONTAL POSITION) BUTTON

Press repeatedly to control the horizontal position of the programmable display on the monitor.

14. ALARM INDEX BUTTON

Press this button to cause the INDEX indicator to light, and set the VCR to the visual search mode (press F.FWD or REWIND during playback mode) in this state; the start of the alarm recorded can be located.

15. ALARM RESET BUTTON

Press to clear POWER LOSS information. When this button is pressed, the alarm memory is cleared.

16. COUNTER RESET BUTTON

Press to clear the digital counter to "00000".

17. REC/PLAY HOURS BUTTONS

▲ (UP): Press to increase hours to the next higher value.

▼ (DOWN): Press to decrease hours to the next lower value. The tape speed will be indicated as part of the monitor display.

18. TIMER BUTTON

Press after programming the TIMER for automatic TIMER recording. See page 15 for TIMER programming.

19. SUMMER TIME BUTTON

Press to set the summer time. See "SUMMER TIME FUNCTION" on page 15 for details.

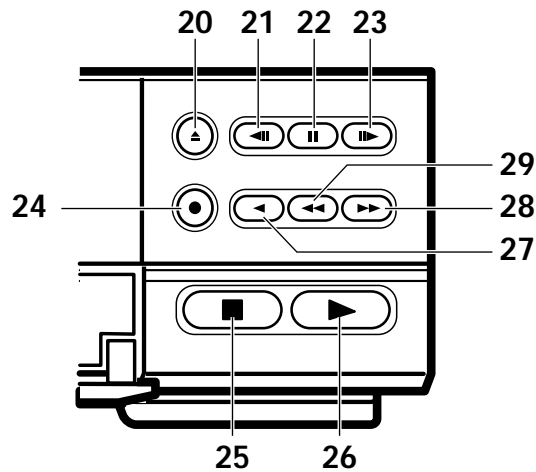

20. EJECT BUTTON

Press to remove the cassette. The EJECT button will not operate in the RECORD mode.

21. FIELD REVERSE BUTTON

Press to reverse the tape by one field in the STILL playback mode.

22. STILL BUTTON

Press to momentarily stop tape motion in the play mode. The STILL function allows close inspection of individual scenes. See the description of STILL playback on page 22.

23. FIELD ADVANCE BUTTON

Press to advance the tape one field in the STILL playback mode.

24. RECORD BUTTON

Press to start recording.

25. STOP BUTTON

Press to stop the tape. The STOP button must be pressed to end the RECORD and PLAY mode.

26. PLAY BUTTON

Press to play recorded material in the forward direction. Pressing this during recording makes it possible to check recordings.

27. REVERSE PLAY BUTTON

Press to play recorded material at the 09, 72, 120, 168, 240 speed in the reverse direction during the PLAY mode.

28. FAST FORWARD/VISUAL SEARCH BUTTON

Press to activate fast forward. Press this button during playback and a forward playback picture at high speed can be seen.

29. REWIND/VISUAL SEARCH BUTTON

Press to start rewind. Press this button during playback and a reverse playback picture at high speed can be seen.

CONTROLS AND FUNCTIONS (Continued)

[DISPLAY]

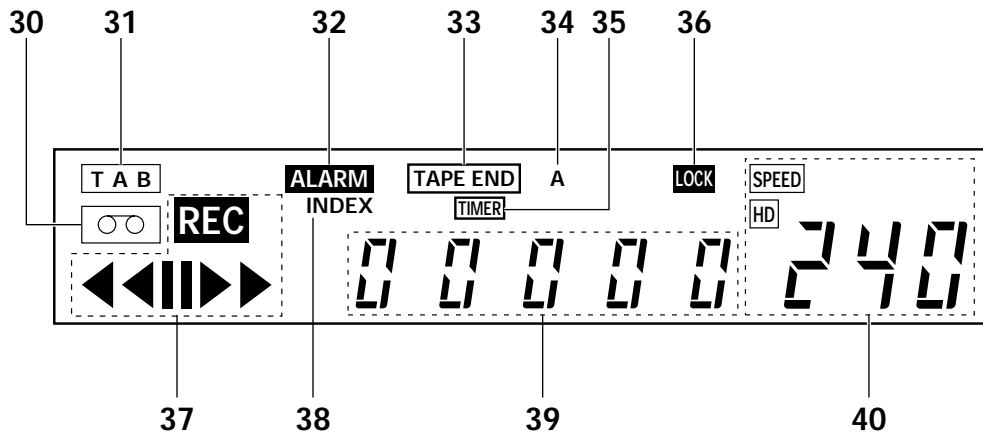

30. TAPE-IN INDICATOR

Lights when a cassette is in the compartment.

31. TAB INDICATOR

Lights when a cassette without its safety tab is loaded.

32. ALARM INDICATOR

ALARM appears during alarm recording.
ALARM flashes when alarm recording ends.

33. TAPE END INDICATOR

Lights when the tape reaches the end during recording.

Note: "TAPE END" is not displayed when you have selected REWIND, RE-REC in the "RECYCLE FUNCTIONS" menu in the alarm display or you have selected REWIND, STOP IF ALARM but an alarm recording has not been made.

34. A INDICATOR

Lights when no video signal is input. Video signal input will turn this indicator off automatically.

35. TIMER INDICATOR

This is lit during timer recording or TIMER stand-by mode.

The indicator flashes in the following cases.

- A cassette is not loaded.
- A cassette without its safety tab is loaded.
- The timer has not been programmed.

36. LOCK INDICATOR

LOCK appears when the recorder is in the security lock mode.

37. VCR MODE INDICATORS

- **REC** appears during recording.
- **◀◀** appears during the rewind mode.
- **▶▶** appears during the fast forward mode.
- **◀◀** (or **▶▶**) flashes during visual search.
- **▶** appears during the playback mode.
- **◀** appears during the reverse play mode.
- **||** appears when the STILL button is pressed during play mode and disappears when the STILL or PLAY button is pressed again.
- **◀||** (or **||▶**) appears while the FIELD REV (or FIELD ADV) is held depressed in the still playback mode.

Note: Still playback is restored when the FIELD REV (or FIELD ADV) button is released.

38. INDEX INDICATOR

INDEX appears when the ALARM INDEX button is pressed.

INDEX disappears when the ALARM INDEX button is pressed again.

INDEX flashes during alarm indexing.

39. DIGITAL COUNTER

Shows the tape counter. The counter does not count during non-recorded sections of a tape.

40. TAPE SPEED INDICATOR

Shows the tape speed.

[REAR]

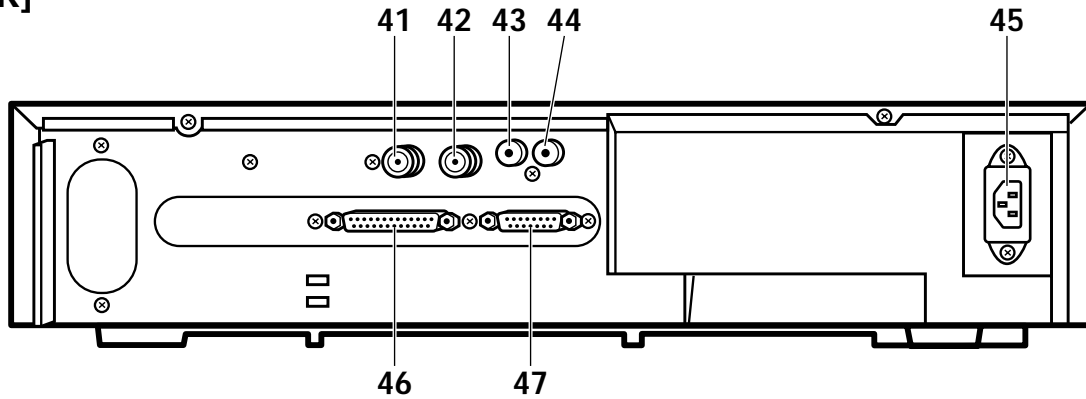

41. VIDEO IN

Receives video signal from a video camera or another VCR.

42. VIDEO OUT

For connection to monitor.

43. AUDIO IN

Accepts an audio signal from a camera, external sound equipment or another recorder (Line: -8 dBm, 50 Kohm, unbalanced).

44. AUDIO OUT

Provides an audio output for a monitor or another recorder (-9 dBm, 600 ohm, unbalanced).

45. AC INLET

46. RS-232C INTERFACE (D-SUB25) JACK

Used to operate this VCR from a personal computer on control system.

47. EXTERNAL INTERFACE (15-PIN) JACK

Connect an alarm switch, door sensor, etc. using the 15-pin adapter provided.

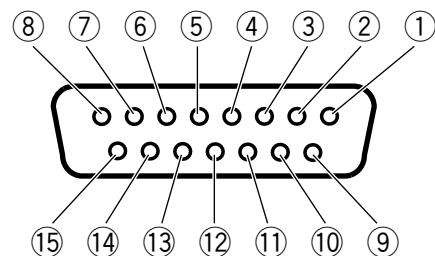

- ① ALARM (A) IN
- ② ALARM OUT
- ③ ONE SHOT IN
- ④ TAPE END OUT
- ⑤ TAPE END RESET
- ⑥ WARNING OUT
- ⑦ ALARM B IN
- ⑧ TIME ADJUST
- ⑨ CAMERA SW OUT
- ⑩ REC START IN
- ⑪ REC OUT
- ⑫ LOW TAPE OUT
- ⑬ REMOTE IN
- ⑭ REC CHECK IN
- ⑮ GND

INSTALLATION

VIDEO CONNECTIONS

Use coaxial cables when connecting a camera and a monitor to this VCR.

Note: Long cable runs to distant cameras may cause signal deterioration and/or sync discrepancies. If these problems occur, use video line amplifiers and/or cameras having phase-adjustable line-locked vertical sync.

Video Input

In single camera systems, connect the camera to the Video IN BNC terminal on the VCR rear panel. Use of a 2:1 interlace camera is highly recommended; otherwise, the monitor will show vertical distortion of the TIME/DATE characters.

In multiple camera systems, connect the switcher output to the Video IN BNC terminal. Because multiple camera systems require synchronization, use of cameras having line-locked vertical sync or a gen-locked master drive/sync source is highly recommended. The use of vertical interval switchers is also recommended.

Video Output

Connect the monitor to the Video OUT BNC terminal on the rear panel.

AUDIO CONNECTIONS

Note: Audio recording can be performed at the 09 and 27-hour recording speeds and audio playback at the 09 and 27 speeds.

Audio In: Accepts an audio signal from a camera, external sound equipment, or another recorder (Line: -8 dBm, 50 kohm).

Audio Out: Provides an audio output for a monitor or another recorder (-9 dBm, 600 ohm, unbalanced).

USING THE 15-PIN ADAPTER

Attach the wires of the alarm switch, door sensor or warning lamp to the 15-pin adapter using screws.

After connection, connect the adapter to the EXTERNAL INTERFACE jack on the rear of the VCR.

See pages 10 and 11 for details.

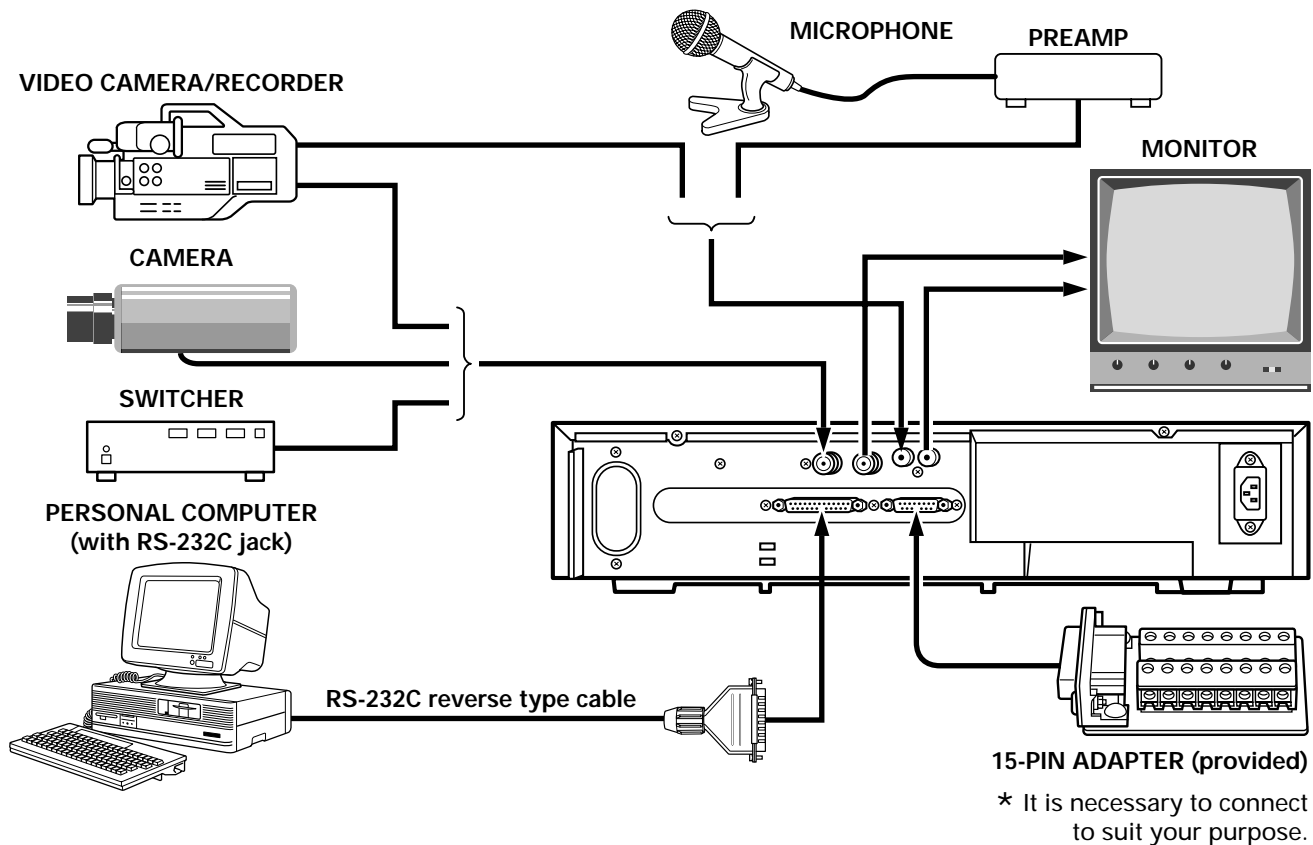

Functions of RS-232C Connector Pins

- | | |
|------------------------------------|------------------------|
| 1. Ground | 2. Data transmission |
| 3. Data reception | 4. Connected to pin 5. |
| 6. Connected to pin 20. | 7. Ground |
| 8 - 19 and 21 - 25. Not connected. | |

Note: The RS-232C is a standard null-modem cable that can be purchased locally.

EXTERNAL CONNECTIONS

Pin Arrangement of 15-Pin Adapter

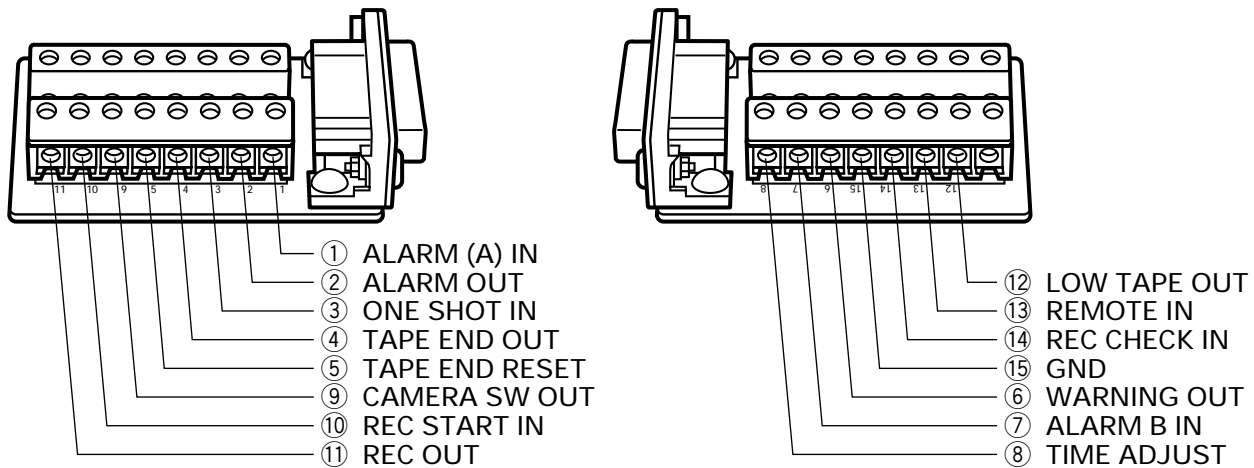

ALARM (A) IN/ ALARM B IN

You can connect two devices including an alarm switch with a resistance of 1 kohm or less or a door sensor. Connect pin ① or ⑦ to pin ⑮ (ground) through the switches.

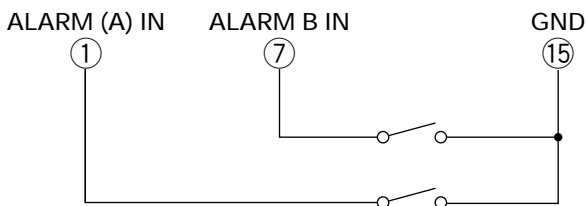

Notes:

- Do not apply a voltage to pin ①, ⑦ or ⑮.
- If an alarm is input to the ALARM (A) IN terminal when an alarm is being input to ALARM B IN, the input at ALARM (A) IN has priority. However, an alarm at ALARM B IN is not accepted when an alarm is being input to ALARM (A) IN.
- The recording conditions are different for the alarms input to the ALARM (A) IN and ALARM B IN terminals. See page 19 for details.

ALARM OUT

Approx. 12V is applied to pin ② during an alarm recording.

Notes:

- When you have selected "PULSE" in the "ALARM OUT" menu in the ALARM display, approx. 12V pulses will be applied to the output after the alarm recording ends.
- When you have selected "DURATION" in the "ALARM OUT" menu in the ALARM display, no voltage is applied after the alarm recording ends.
- The output impedance is approx. 100 ohm.

ONE SHOT IN

One shot recording is possible when pin ③ is shorted to pin ⑮.

Note: Do not apply a voltage to pin ③ or ⑮.

TAPE END OUT

Approx. 12V is applied to pin ④ when the tape reaches the end.

Notes:

- This does not operate when you have selected "REWIND, RE-REC" in the "RECYCLE FUNCTIONS" menu in the ALARM display or you have selected "REWIND, STOP IF ALARM" and no alarm recording has been made.
- The output impedance is approx. 100 ohm.

TAPE END RESET

The TAPE END OUT can be turned off when pin ⑤ is shorted to pin ⑮.

Note: Do not apply a voltage to pin ⑤ or ⑮.

EXTERNAL CONNECTIONS (Continued)

CAMERA SW OUT

Pin ⑨ outputs the following signal each time a one-field image is recorded. You can combine this with a video camera switcher which can be controlled externally.

The output timing can be specified using the SELECTION MENU screen.

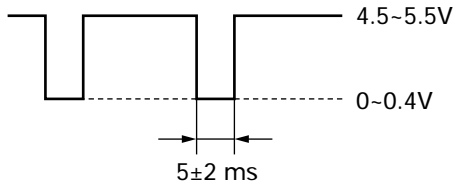

REC START IN

Recording is started when 5 ~ 12V is applied to pin ⑩.

REC OUT

Approx. 5V is applied to pin ⑪ during recording. The output impedance is 4.7 kohm at this time. The output stops when recording is interrupted.

LOW TAPE OUT

During recording, when the digital counter counts up to "32400", approx. 12V is applied to pin ⑫. Use this function as a reference to judge when the tape is near its end.

The output stops when a TAPE END RESET pulse is input or the EJECT button is pressed.

Note: The output impedance is approx. 100 ohm.

REMOTE IN

This VCR can be remote controlled when the following circuit is connected to pin ⑬.

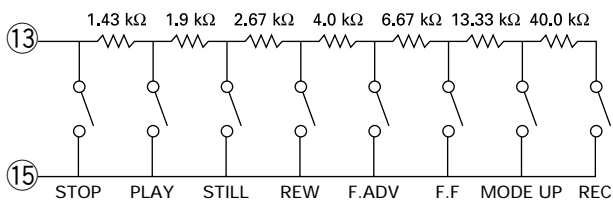

The above resistance values have a tolerance of ±2%.

REC CHECK IN

Recording can be checked when pin ⑭ is shorted to pin ⑮ during recording mode. The recorded material is played back for several seconds so that you can check whether recording is made normally or not.

WARNING OUT

When an abnormality has occurred in this VCR, approx. 5V is output to pin ⑥ to warn the user.

TIME ADJUST

When two or more of this VCR model are used, connect via these terminals. With only one VCR, specify TIME ADJUST: MASTER, in [OPTIONS] items on the CLOCK SET display. Specify TIME ADJUST: SLAVE (default setting at the factory) for all other VCRs. Each time "2:00:05" is reached, the VCR set to MASTER transmits pulses for adjustment to the VCRs set to SLAVE. When the VCRs set to SLAVE receive these pulses, their clocks will adjust to the same time as the clock in the VCR set to MASTER.

Note: Be sure to set only one VCR to MASTER. If no VCR is set to MASTER, or two or more VCRs are set to MASTER, the TIME ADJUST function will not operate normally.

CASSETTE TAPES

It is recommended that you use standard grade VHS video tapes of the following makers:

maxell TDK Fuji

TAPE LIFE

Slower speed operation in time lapse recording applies stress to video tape. Tapes should be inspected and, if necessary, discarded after the total number of complete tape passes (recording and playback) exceeds the following limits:

Tape Speed	Complete Tape Passes
09, 27	50
48, 72, 120, 168, 240	25
00	2

INSERTING A CASSETTE

Note: This is the first step in all VCR operations. The VCR will not operate without a cassette in place. To insert a cassette push the cassette through the cassette compartment door until the VCR mechanism pulls it into the compartment. The tape-in indicator turns on.

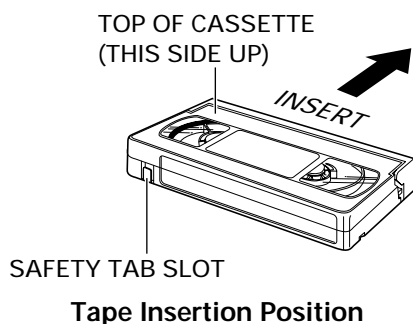

REMOVING A CASSETTE

Before removing a cassette, rewind the tape completely. To remove a cassette, press the EJECT button. The cassette will come partially out of the compartment so you can pull it out.

VIDEO CASSETTE SAFETY TAB

To prevent accidental erasure of recorded material, remove the safety tab from the lower left corner of the cassette.

Recording is impossible when the safety tab is removed.

Notes:

- The TAB indicator lights when a cassette without its safety tab is loaded.
- To record again on a cassette that has its safety tab removed, cover the tab hole with tape. In the TIMER mode, the TIMER indicator will flash on and off if the cassette is inserted without its safety tab slot covered or intact.

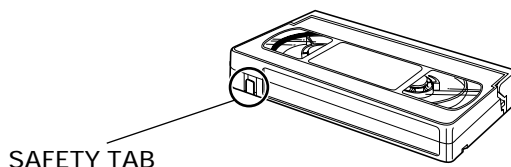

TO PREVENT ACCIDENTAL ERASURE, BREAK OFF THE TAB



TO RECORD AGAIN, COVER THE HOLE WITH TAPE

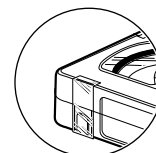

Video Cassette Safety Tab

TAPE LENGTH

The total recording time at each of the eight tape speeds depends on the length of the tape used. The table below shows:

1. The total recording time that can be recorded at each tape speed mode on E90 and E180 tapes.
2. The pictures per second at each speed.
3. The speeds at which audio can also be recorded.

Use the table to select the tape length which gives the best compromise between tape cost, total recording time, and elapsed time between pictures.

Tape Speed Mode		00	09	27	48	72	120	168	240
Total Recording Hours	E90	—	4.5	13.5	31.5	40.5	67.5	85.5	121.5
	E180	—	9	27	63	81	135	171	243
Pictures/Second	RECORD	2.9	50	16.7	7.14	5.6	3.3	2.6	1.9
	PLAYBACK	—	50	16.7	7.14	5.6	3.3	2.6	1.9
Audio	RECORD	No	Yes	Yes	No	No	No	No	No
	PLAYBACK	No	Yes	Yes	No	No	No	No	No

Note: The values in this table are approximate.

SETUP

On-Screen displays are provided to aid setup of the programmable functions. The six functions on the Program Menu appear individually on the monitor in this order.

1. CLOCK SET
2. TIMER
3. SELECTION MENU I
4. SELECTION MENU II
5. ALARM
6. ALARM MEMORY

CLOCK SET	<pre>(CLOCK SET) 1-01-1999 FRI 0:00: (OPTIONS) OSD TYPE: OFF TIME ADJUST: SLAVE</pre>
TIMER DISPLAY	<pre>(1) 0:00 → 0:00 09 (2) 0:00 → 0:00 09 (3) 0:00 → 0:00 09 (4) 0:00 → 0:00 09 (5) 0:00 → 0:00 09 (6) 0:00 → 0:00 09 (7) 0:00 → 0:00 09 MON:* * TUE:* * WED:* * THU:* * FRI:* * SAT:* * SUN:* *</pre>
SELECTION MENU I	<pre>(SELECTION MENU) VIDEO MODE: AUTO SEARCH SPEED: X5 ONE SHOT REC: 6FIELDS BAUD RATE: 9600BAUD CAMERA SW: ALL</pre>
SELECTION MENU II	<pre>(SELECTION MENU) BUZZER SELECTION TAPE END: OFF TROUBLE: OFF NO VIDEO: OFF AUTO REC CHECK: OFF ALARM OUT: OFF</pre>
ALARM DISPLAY	<pre>(ALARM SET) DURATION: MANUAL SPEED: 09 ALARM READY: YES ALARM OUT: DURATION (RECYCLE FUNCTIONS) REWIND, STOP IF ALARM</pre>
ALARM MEMORY DISPLAY	<pre>(ALARM MEMORY) A00 1 2 3 4 5 6 7 8 9</pre>

Initial Program Function Display Formats

Note: If the VCR is not turned on for about 720 hours after the built-in battery is fully charged (after the VCR is turned on for more than 48 hours), the TIME/DATE display will be cleared.

SELECTING A FUNCTION TO BE PROGRAMMED

The program menu will always begin with the CLOCK SET function, followed by the TIMER, SELECTION MENU I, SELECTION MENU II, ALARM, and then the ALARM MEMORY functions. Although the program menu always follows this order, it is possible to skip any of the available functions during the selection process.

To select the desired program function (and to move from one program function to the next), press the PROGRAM button repeatedly until the desired function display format appears on the monitor.

After the desired function has been selected, follow the corresponding procedure to set that function.

SETTING THE PROGRAM FUNCTION(S)

The first step in each programming procedure is: "Press the START/STOP button". The system allows up to five minutes for any one function setting to be completed after the START/STOP button is pushed. If no change/setting is entered within the five minutes period, the unit will automatically exit the selected program function. (If this happens, re-select the desired program function, and follow the programming procedure for that function.)

The following procedures for setting VCR functions assume that the desired function has already been selected.

Note: During programming, holding the SET, UP, or DOWN button will move/change the displayed information at a rapid rate.

SETTING THE TIME AND DATE

Use the CLOCK SET display to set the date and time.

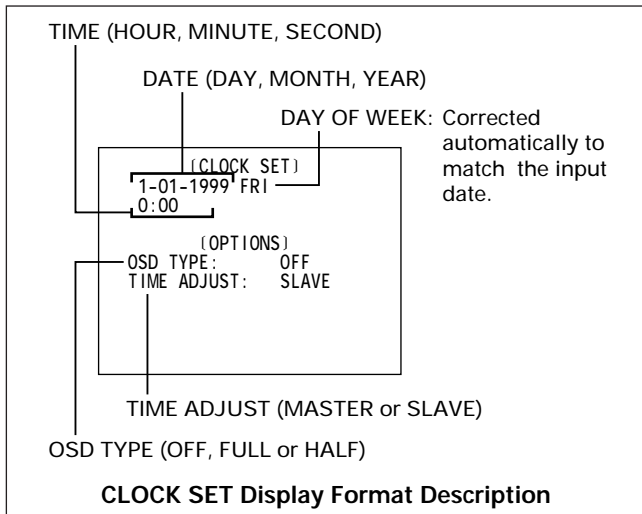

1. Press the START/STOP button so that [CLOCK SET] flashes on/off.
2. Press the SET button. The day flashes on/off.
3. Press the UP or DOWN button until the desired number appears on the monitor.
4. Press the SET button. The month flashes on/off.
5. Press the UP or DOWN button until the desired number appears on the monitor.
6. Press the SET button. The year flashes on/off.
7. Press the UP or DOWN button until the desired number appears on the monitor.
8. Press the SET button. The hour flashes on/off.
9. Press the UP or DOWN button until the desired number appears on the monitor.
10. Press the SET button. The minutes flash on/off.
11. Press the UP or DOWN button until the desired number appears on the monitor.
12. Press the START/STOP button: the seconds will start counting and the clock will start. [CLOCK SET] will flash on/off again at this time.
13. To display the time/date you have set here on the monitor screen, press the START/STOP button again to cause [OPTIONS] to flash, and then proceed with step 2 in item on OSD TYPE on page 15.
14. Press the START/STOP button three times.
 - Make sure that letters [CLOCK SET] or [OPTIONS] are not flashing.

Notes:

- Perform the same procedure as when setting the time and date to make corrections after having set them. The minutes flash on/off when the SET button is pressed (in step 2 above).
- To record time and date on the tape, display them on the monitor screen. If they are not displayed on the monitor, they cannot be recorded on the tape.

SETUP (Continued)

SETTING [OPTIONS] ITEMS

OSD TYPE: The TIME/DATE display was not designed to appear at the factory. If you wish to record the time/date together with image, perform the following procedure:

There are two types of TIME/DATE display: FULL and HALF.

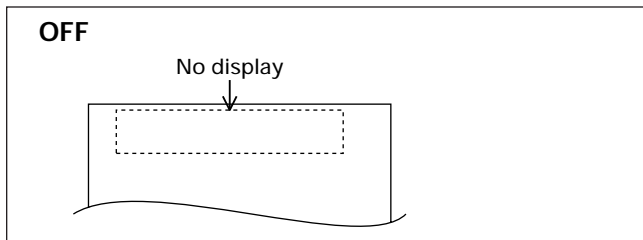
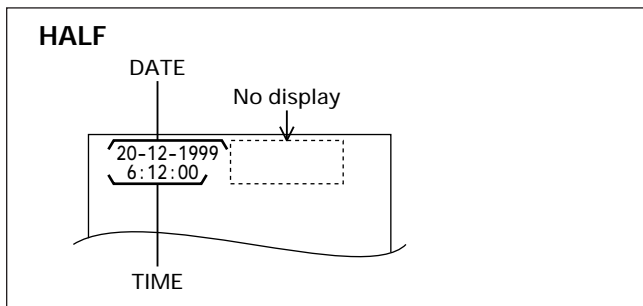
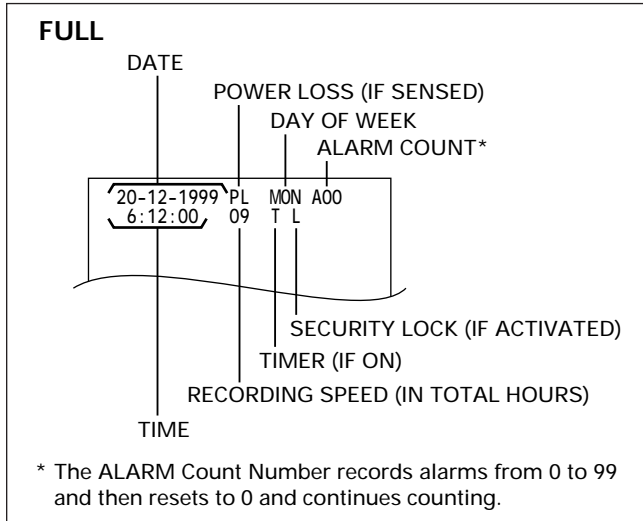

1. Press the START/STOP button twice so that [OPTIONS] flashes on/off.
2. Press the SET button so that the OSD TYPE: setting flashes on/off.
3. Press the UP or DOWN button to select the setting (OFF, FULL or HALF).
4. Press the START/STOP button again. The selected setting will light.

Note: The position of the TIME/DATE display on the monitor can be adjusted by using the H-POS and V-POS button on the front panel.

TIME ADJUST: When two or more of this VCR model are connected to pins ⑧ TIME ADJUST of each EXTERNAL INTERFACE jack, the clocks in both VCRs can automatically be set to the same time (TIME ADJUST function).

To use the TIME ADJUST function, set one VCR to MASTER and any others to SLAVE.

1. Press the START/STOP button twice so that [OPTIONS] flashes on/off.
2. Press the SET button twice so that the TIME ADJUST: setting flashes on/off.
3. Press the UP or DOWN button to select the setting (SLAVE or MASTER).
4. Press the START/STOP button again. The selected setting will light.

Notes:

- You can set OSD TYPE and TIME ADJUST after you have set the date and time.
- The TIME ADJUST function operates only when the VCRs are turned on. Therefore, turn the VCRs on around 2:00:05. This function will not operate if the times on the MASTER and SLAVE VCRs drift by more than one hour and 30 minutes.

SUMMER TIME FUNCTION

Set the summer time function when a cassette is not loaded in this VCR.

Press the SUMMER TIME and UP buttons simultaneously in modes other than the timer recording standby mode; the hour display will be counted up by one.

Press the SUMMER TIME and DOWN buttons simultaneously to count the hour display down by one.

You can change the hour display in one-hour steps without any limit by pressing the above buttons.

Note: Summer time cannot be set unless TIME/DATE is displayed.

SETTING THE TIMER

To set the 24 Hour On/Off Timer function

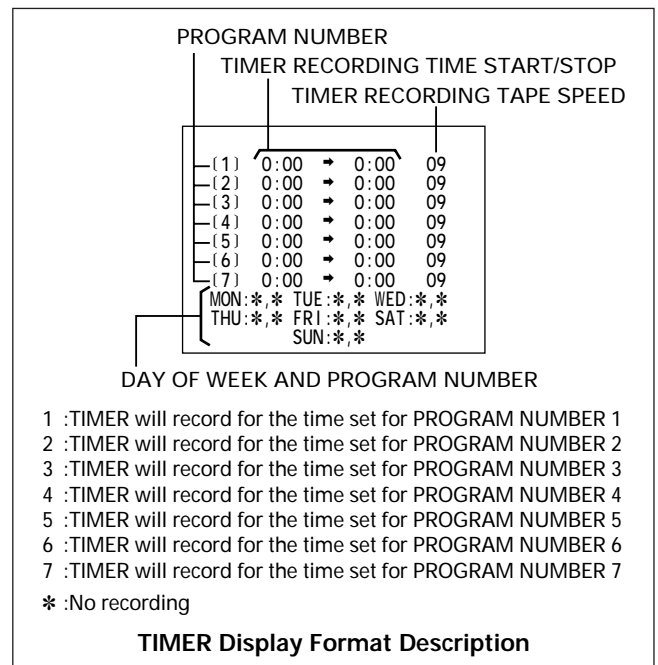

1. Press the START/STOP button.
The program number (1) flashes on/off.
2. Press the SET button. The start hours flash on/off.
3. Press the UP or DOWN button until the desired number appears on the monitor.
4. Press the SET button. The start minutes flash on/off.
5. Press the UP or DOWN button until the desired number appears on the monitor.
6. Press the SET button. The stop hours flash on/off.
7. Repeat steps 3 through 5 to set the stop hours and minutes.
8. Press the SET button. The timer recording speed flashes on/off.
9. Press the UP or DOWN button until the desired number appears on the monitor.
10. Press the SET button after setting the timer recording speed. The program number of the next lower line flashes on/off.
11. Repeat steps 2 through 9 to set the program to the other program numbers.
12. Press the SET button after setting the program numbers (1) through (7).
The two program event locations of MON flash on/off.
13. Press the SET button. The first program event location of MON flashes.
14. Press the UP or DOWN button until the desired program number appears on the monitor.
15. Press the SET button. The other program event location of MON flashes on/off.
16. Press the UP or DOWN button until the desired program number appears on the monitor.

Notes:

- If you do not need to timer record two events a day, mark either event with an asterisk (*).
 - If two asterisks are displayed, no timer recording is made on that day.
17. After setting two program event locations of MON, press the SET button. The two program event locations of the next day of the week flashes on/off.
 18. Press the SET button. The first program event location of the next day flashes.
 19. Repeat steps 12 through 16 to set the program event locations up to SUN.
 20. Press the START/STOP button when the TIMER has been set.

Notes:

1. Programming the TIMER function does not activate it. See TIMER recording, page 21.
2. To record the time and date press the PROGRAM button to display them.
3. When the preset START time is later than the STOP time, the recording will be made into the following day.
4. When the START time and STOP time are the same, a recording will not be made.
5. When the programs for timer recording overlap each other, recording will be switched to the program with the later recording start time.

Example

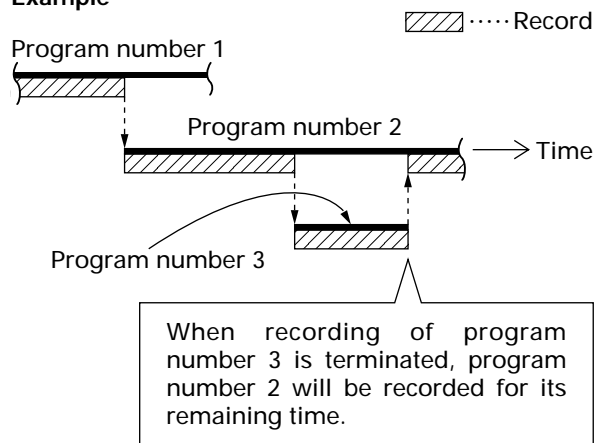

6. When two programs have the same start time, the program number with the earlier stop time has priority.

■ **To correct information**

1. Press the START/STOP button.
2. Press the UP or DOWN button repeatedly until the item to be corrected (Program number or program event location of day of the week) flashes on/off.
3. When the section to be corrected flashes on/off, press the SET button.
 - Press the SET button again so that only the digit to be corrected flashes on/off.
4. Press the UP or DOWN button to correct the set information.
5. After completing the correction, press the START/STOP button.

SETUP (Continued)

SETTING THE VCR FUNCTIONS

The SELECTION MENU I screen allows you to select the VCR operations and functions to match the applications.

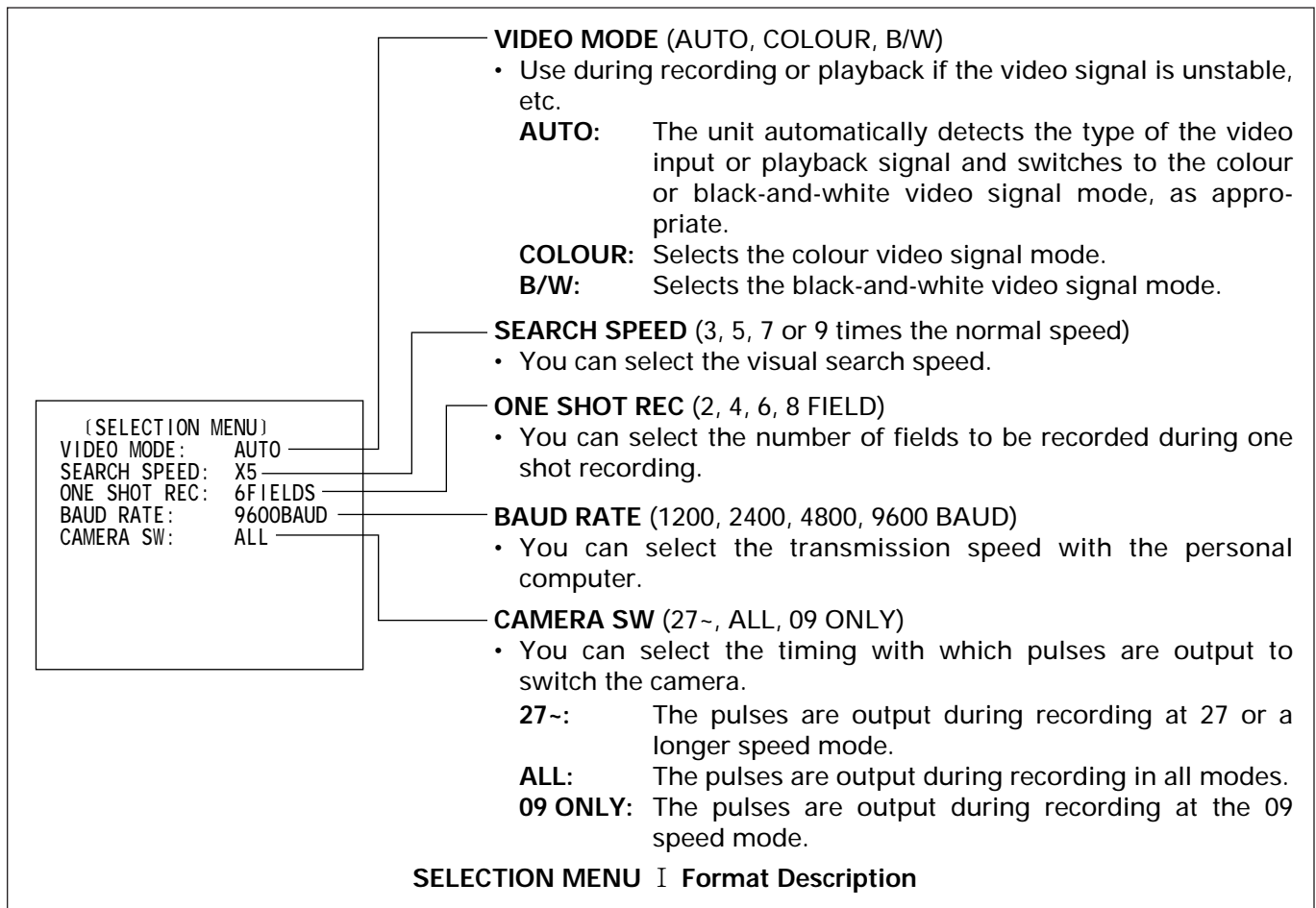

1. Press the START/STOP button.
The VIDEO MODE option "AUTO" flashes on/off.
2. Press the SET button repeatedly until the item the setting of which you want to change flashes.
3. Press the UP or DOWN button to select the value or setting you want.
4. After selecting, press the START/STOP button.

SETTING THE BUZZER

This VCR has a buzzer function.

Use SELECTION MENU II to select the times when you wish buzzer to sound.

Note: "OFF" is specified for all buzzer options at the factory.

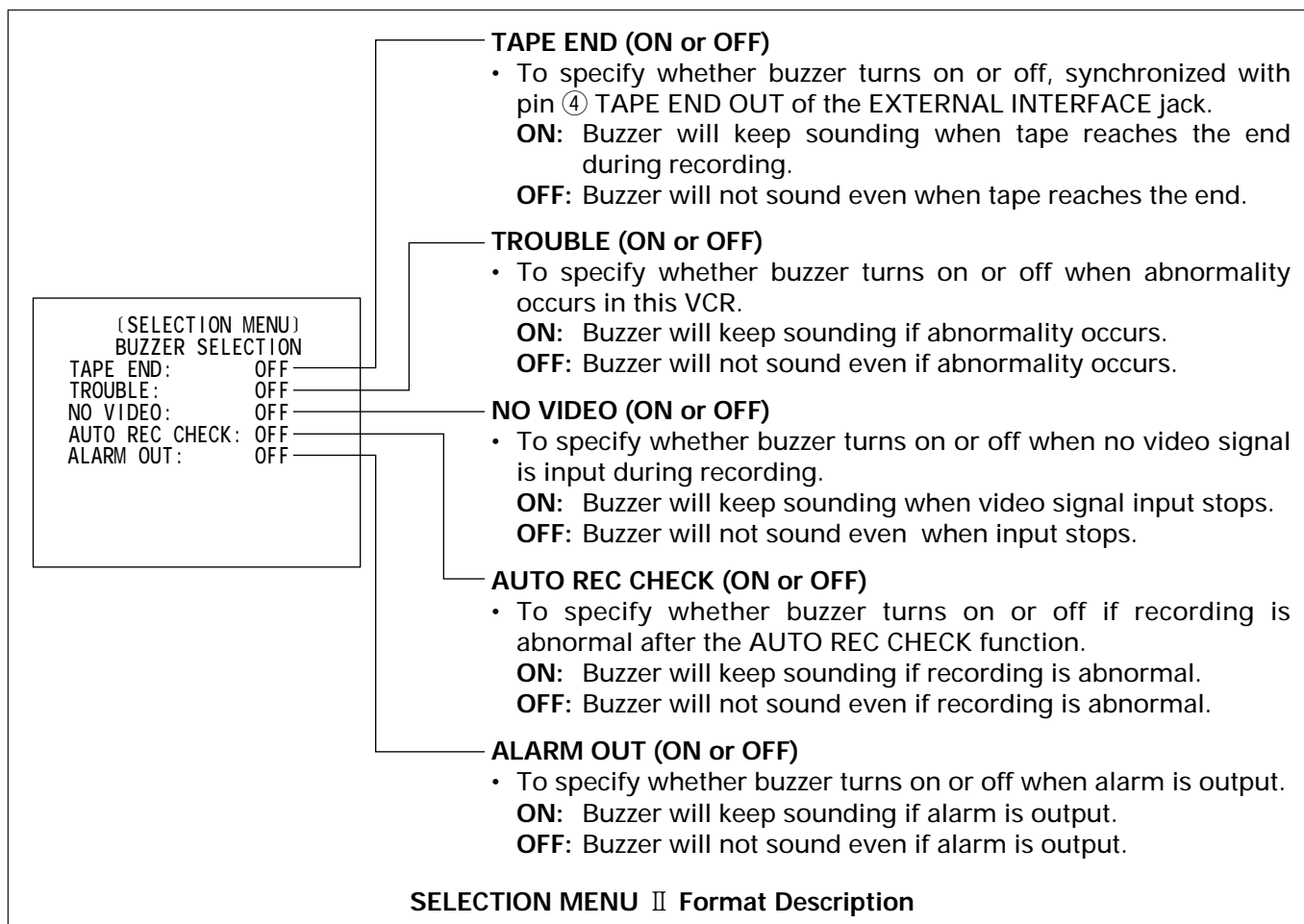

1. Press the START/STOP button.
The TAPE END option "OFF" flashes on/off.
2. Press the SET button repeatedly until the item the setting of which you want to change flashes.
3. Press the UP or DOWN button to select the value or setting you want.
4. After selecting, press the START/STOP button.

To stop buzzer:

1. When [TAPE END] lights in the VCR display, press the EJECT button: The tape will come out and the buzzer will stop.
2. When "A" lights in the VCR display and also "NO VIDEO" appears on the monitor screen, the buzzer will stop when video signal is input.
3. When "REC CHECK" appears on the monitor screen, press the STOP button: The buzzer will stop.
4. When alarm indicator [ALARM] flashes in the VCR display, press the ALARM RESET button: The buzzer will stop.
5. If buzzer function varies in any of the above cases, the VCR may be abnormal. Press the RESET buttons simultaneously: The buzzer will stop. However, note carefully that all settings will return to initial values set at the factory.

Note: You can also stop buzzer by switching ON to OFF in SELECTION MENU II.

SETUP (Continued)

SETTING THE ALARM

The ALARM function allows the user to set the recording duration, speed to be recorded and tape recycle for alarm recordings. When a contact closure occurs at the ALARM B IN input, the VCR automatically enters the RECORD mode at the pre-programmed ALARM recording speed. (See Alarm In, page 10 for a complete description of the ALARM sequence.) The ALARM recording duration can last according to the set value, or until the contact closure is reopened.

The ALARM recording speed can be pre-programmed to 09~240.

The checking signal is automatically recorded on the tape at the beginning of each ALARM recording. Later, you can easily locate the start of each recording by using these signals when watching a recorded content. See "ALARM INDEX SEARCH" on page 23 for details.

See page 15 if you also want to record the date/time. The TIME/DATE display is set as follows during ALARM display.

- ALARM stars (*) will replace the colons (:).
- The recording speed will be changed to 09~240 which was selected at the "SPEED" setting in the ALARM display.

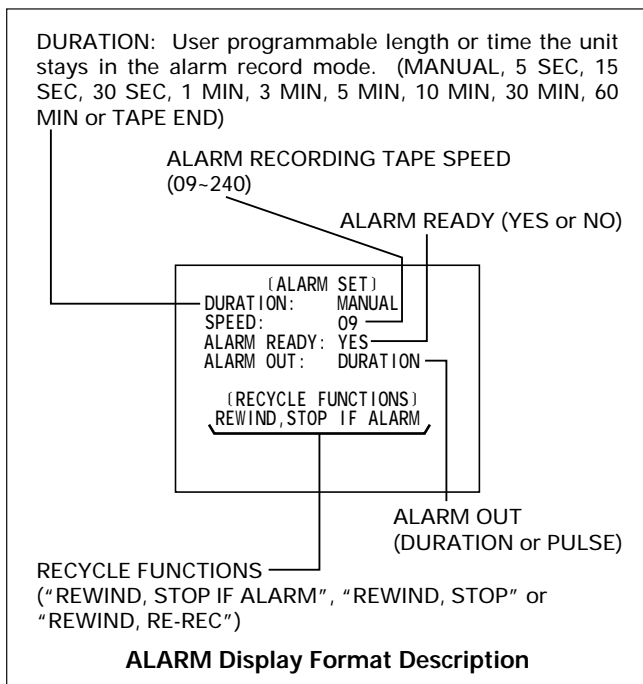

Notes:

- When the ALARM recording ends, the VCR will return to the status it was in before the alarm was input.
 - Select 09 at the "SPEED" setting when the duration is within 30 seconds. If the 27~240 speed is selected, electronic "marks" are not recorded on the tape and alarm index search will not operate.
1. Press the START/STOP button. The duration setting flashes on/off.
 2. Press the UP or DOWN button until the desired setting appears on the monitor. (MANUAL, 5, 15, 30 SEC, 1, 3, 5, 10, 30, 60MIN, TAPE END)
 3. Press the SET button. The record speed setting flashes on/off.
 4. Press the UP or DOWN button until the desired setting appears on the monitor. (09~240 HR.)
 5. Press the SET button. The alarm ready setting flashes on/off.
 6. Press the UP or DOWN button to select the alarm ready function. (YES or NO)
 Select "YES" if you want to start alarm recording even in the normal record or stop mode.
 Select "NO" if you do not want alarm recording in the stop mode.
 7. Press the SET button. The alarm out setting flashes on/off.
 8. Press the UP or DOWN button to select the alarm out function. See "ALARM OUT" on page 10 for details. (DURATION or PULSE)
 9. Press the SET button.
 The RECYCLE position flashes on/off.
 10. Press the UP or DOWN button to select the mode at the end of tape. See "TAPE RECYCLE" on page 21 for details.
 11. Press the START/STOP button.
 Programming for the ALARM has been completed.

Caution when input to ALARM (A) IN:

The conditions for recording an alarm input to ALARM (A) IN are fixed as follows.

Note: The ALARM READY function can be specified as YES or NO.

[Conditions for recording the input to ALARM (A) IN]

DURATION: MANUAL

MODE: 09

ALARM OUT: DURATION

RECYCLE FUNCTION: REWIND, STOP IF ALARM

ALARM MEMORY RECALL AND RESET

The VCR signals that an alarm has occurred by flashing the ALARM indicator. If a power loss has occurred, "PL" will appear in the first line of the FULL type TIME/DATE display.

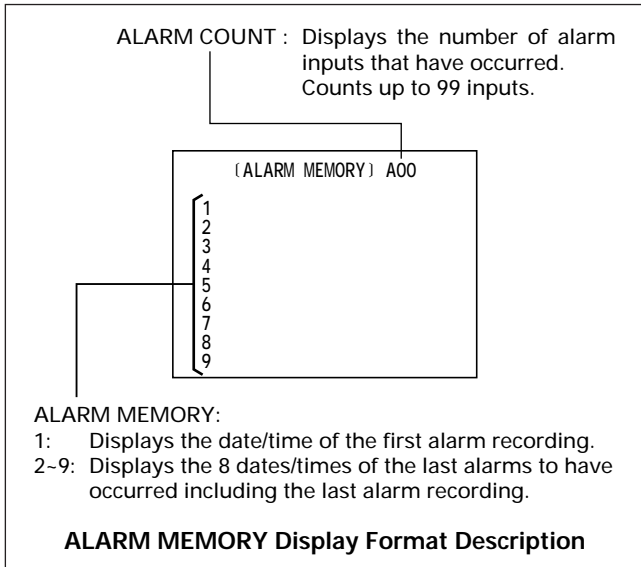

To recall the ALARM display:

1. Press the PROGRAM button until the ALARM MEMORY display appears on the monitor.
2. Log the time/date information from the ALARM memory.

To reset the ALARM memory:

- When the ALARM RESET button is pressed once, if "PL" is flashing, "PL" will disappear. Press the button again to clear the ALARM memory.
- When "PL" is not flashing, press the ALARM RESET button once to clear the ALARM memory.

OPERATION

TAPE RECORDING

CAUTION: Recording over existing recorded material will completely erase that material. To prevent accidental recording over the end of a previous recording, advance the tape several seconds before beginning the next recording.

1. Insert a video cassette; be sure the cassette safety tab is intact, or the tab slot is covered.
2. Press the REC/PLAY HOURS button until the desired tape speed is observed on the tape speed indicator.
3. Press the RECORD button to start recording.
4. Press the STOP button to stop recording.

Notes:

- The tape speed mode can be changed during recording.
- AUDIO can be recorded at 09 or 27 tape speed modes.
- “NO VIDEO” will be displayed when no video signal input during recording.

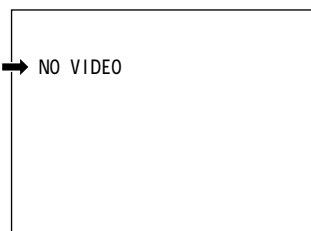

This VCR offers three special recording functions, ONE SHOT recording, TIMER recording and ALARM recording.

REC CHECK

This function allows you to check whether the pictures are being recorded normally or not during recording.

When the PLAY button is pressed during recording, the recorded picture is played back for several seconds. Then recording will continue.

TAPE RECYCLE

The “RECYCLE FUNCTIONS” in the ALARM display determine the mode after recording at the end of tape.

When the “REWIND, STOP IF ALARM” is selected:

- If no alarm has been received during the recorded period, the VCR automatically rewinds to the beginning of tape and continues recording.
- If an alarm has been received via the ALARM (A) IN terminal during the recording period, the VCR automatically rewinds to the beginning of tape and then enters the STOP mode.

AUTO REC CHECK

If tape reaches the end during recording, this function allows the VCR to automatically rewind the tape and play it back for several seconds. If AUTO REC CHECK detects from playback that the tape has been normally recorded, the VCR will rewind the tape to its start. If AUTO REC CHECK detects that the tape has not been normally recorded, “REC CHECK” will appear at the top left of the monitor screen.

Note: If “AUTO REC CHECK: ON” is specified in SELECTION MENU II, the buzzer will keep sounding when tape has not been normally recorded.

ONE SHOT RECORDING

In the ONE SHOT mode, the contact closure at the input contact ONE SHOT IN, triggers the recording of 6 fields, the recording of 5.6 fields per second.

If the next signal is not received in approx. 3 minutes, the VCR will automatically record 6 fields. This process will be repeated approx. every 3 minutes.

To record in this mode; follow the tape recording procedure, steps 1 through 3, setting the tape speed mode at 00.

You can select the number of fields to be recorded in the ONE SHOT REC mode using the SELECTION MENU screen.

TIMER RECORDING

This VCR can also record at any speed on TIMER command (turn on/off to record during any 24-hour time period). To program the TIMER function, refer to pages 15 and 16.

To operate the TIMER recording function, follow the tape recording procedure, step 1, then press the TIMER button to activate the programmed TIMER function.

Notes:

- Pressing the TIMER button is not accepted during playback.
- If a start time for timer recording is reached during normal recording, timer recording is started. After the timer recording finishes, the previous normal recording mode is restored.

When “REWIND, STOP” is selected:

- When the tape reaches the end during recording, the VCR automatically rewinds to the beginning of tape and enters the STOP mode.

When “REWIND, RE-REC” is selected:

- When the tape reaches the end during recording, the VCR automatically rewinds to the beginning of tape and continues recording.

Note: When “REWIND, STOP” or “REWIND, RE-REC” is selected, the VCR operates whether an alarm has occurred or not.

Recycle	Alarms Present on Recorded Tape	Results
REWIND, STOP IF ALARM	YES	Rewinds tape, then stops. Will not respond to alarm input.
	NO	Rewinds tape then continues to record.
REWIND, STOP	YES	Rewinds tape, then stops. Will not respond to alarm input.
	NO	Rewinds tape, then stops. Will not respond to alarm input.
REWIND, RE-REC	YES	Rewinds tape then continues to record.
	NO	Rewinds tape then continues to record.

ALARM RECORDING

This VCR can automatically record at one of 8 speeds (09~240) on ALARM command.

There are two alarm inputs to ALARM (A) IN and ALARM B IN for which the recording conditions are different.

To program the ALARM function refer to page 19. The remote/contact switch must be connected to the VCR. See page 10.

To operate the ALARM recording in the stop mode: follow the tape recording procedure, step 1, then select "YES" of the ALARM READY menu in the ALARM display.

Note: An alarm input to ALARM (A) IN has priority. When an alarm is input to ALARM (A) IN when an alarm is being input to ALARM B IN the input at ALARM (A) IN is recorded. If an alarm is input to ALARM B IN when an alarm input to ALARM (A) IN is being recorded, the alarm at ALARM (A) IN continues. If the alarm at ALARM B IN continues after recording the alarm at ALARM (A) IN has ended, the alarm at ALARM B IN will be recorded.

MASTER SYSTEM RESET

Press the two reset buttons simultaneously to provide a MASTER SYSTEM RESET. Use to reset abnormal displays and operations. The programmable features must be re-programmed.

PLAYBACK

1. Rewind the tape to the desired beginning point. (Press the REWIND button, and observe the digital counter until the desired number appears.) Press the stop button.
2. Press the REC/PLAY HOURS button until the desired tape speed is observed on the tape speed indicator.
3. Press the PLAY button to initiate forward playback.
To select reverse playback, press the PLAY button and then press the REVERSE PLAY button. Forward playback resumes when the PLAY button is pressed.

Notes:

- When the REVERSE PLAY button is pressed in the forward playback mode to set the VCR to the reverse playback mode, the first several frame images may be distorted.
- When the REVERSE PLAY button is pressed during playback at the 27 or 48 hour speed, reverse play is performed automatically at the 72 hour speed.

- The VCR will automatically enter the STOP mode if the reverse play is continued for approx. 1 minute.

4. Press the STOP button to stop playback.

Notes:

- The tape speed mode can be changed during playback.
- When a picture recorded in the 09 mode is played back in the 27 mode, it includes noise. It is recommended that you play back pictures recorded in the 09 mode at modes higher than 48.
- When the tape reaches the end, the unit automatically rewinds to the beginning of the tape and then goes to the STOP mode.
- If the monitor display exhibits distortion in the upper part of the picture, adjust the horizontal hold control on the monitor.
- Adjust the SLOW TRACKING control to minimize noise when playing back at slow speed (more than 48 Hr).
- The playback picture is not stable and has some noise at 27 mode. And in these modes TRACKING control is not effective.

STILL PLAYBACK

When the STILL button is pressed during playback, a still picture can be seen. To start again press STILL or PLAY button and the VCR will continue playback.

Notes:

- When still playback continues for more than 5 minutes, the AUTO-PROTECT circuit operates and the VCR will enter the STOP mode automatically.
- If the picture shakes up and down during still playback, adjust the V.LOCK control.

V.LOCK ADJUST

If the picture shakes up and down during still playback, adjust the picture by the following procedure.

1. Play back a tape, recorded in the 09 mode, in the still playback mode.
 - With some monitors, if the V.LOCK control is adjusted when playing a tape recorded in modes other than 09, shaking of the still picture may not stop.
2. Adjust the V.LOCK control so the shaking of the picture stops.

Note: Shaking of the picture may not be stopped completely depending on the monitor used.

OPERATION (Continued)

PLAYBACK IN THE FIELD ADVANCE/REVERSE MODES

When you press the FIELD ADVANCE or FIELD REVERSE button during still playback mode, one field at a time can be seen.

Operates only after STILL button has been pressed.

Notes:

- An AUTO-PROTECT circuit automatically returns the unit to the STOP mode if the STILL or PLAY button is not pressed again or if FIELD ADVANCE or FIELD REVERSE button is not pressed in any five minute period.
- When the FIELD REVERSE button is pressed in the still playback mode to set the VCR to the field reverse mode, the first several frame images may be distorted.

VISUAL SEARCH (High Speed Scan)

Note: The visual search function allows the recorded material to be reviewed at 3, 5, 7 or 9 times the 09 hour speed mode.

1. Press the PLAY button.
2. Press the SEARCH (F.FWD) button to select the VISUAL SEARCH FORWARD mode, or press the SEARCH (REWIND) button to select the VISUAL SEARCH REVERSE mode.
3. Press the PLAY button again to resume normal playback.

Notes:

- The visual search speed can be changed using the SELECTION MENU I screen.
- The playback picture will have some noise in the visual search mode.

ALARM INDEX SEARCH

The alarm index search method causes electronic "marks" to be recorded on the tape at each point when the ALARM recording begins.

Later, the VCR can find these "marks" automatically, making it easy to find the beginning of each alarm for playback.

These check points are permanent until the tape is erased. A check mark is recorded automatically each time the VCR starts ALARM recording.

1. Press the PLAY button to start playback.
2. Press the ALARM INDEX button.
3. Press the REW or F.FWD button. The recorder enters VISUAL SEARCH mode.
4. When the VCR finds a mark, it enters normal playback mode.
5. Press REW or F.FWD button again to find next "marked" recording. The recorder advances tape to the next marked position.
6. Press the ALARM INDEX button again to release alarm index search.

Notes:

1. If another alarm comes through ALARM (A) IN when the alarm at ALARM B IN is being recorded, an electronic "mark" is written on the tape. However, an alarm at ALARM B IN is not accepted when an alarm is being input to ALARM (A) IN, so an electronic "mark" is not written on the tape with this ALARM B input.
2. Be careful as no alarm input can be detected for 5 seconds immediately after the visual search mode is entered by pressing the REW or F.FWD button during the alarm index search mode.
3. When tapes recorded by other VCRs are played in the alarm index search mode, the VCR may enter the play mode in a meaningless position.
4. When you have selected "MANUAL" at the DURATION setting in the ALARM display, and the duration of an alarm recording is shorter than the values shown below, "marks" may not be detected.

SPEED

09	15 seconds
27, 48	1 minute
72, 120, 168	3 minutes
240	5 minutes

TO SECURE THE VCR

This feature restricts unauthorized use, tampering, or accidental changes in the operation of the VCR. The security feature does not operate during programming. Simultaneously press the SET and DOWN buttons in the program set area of the front panel. The security message "L" appears in the TIME/DATE display (FULL) and the LOCK indicator lights in the VCR's display.

To release the security feature, press the SET and DOWN buttons simultaneously.

Note: "L" does not appear in the TIME/DATE display (HALF).

OPERATING THE VCR FROM A PERSONAL COMPUTER

Connect this VCR to a personal computer via the RS-232C interface jacks to remote control the VCR by operating the computer. You can also display the status of the VCR on the monitor screen to check it.

■ RS-232C Interface Specifications

- Communication system: Full duplex
- Communication rate: 1200/2400/4800/9600 BAUD (The rate can be specified using the SELECTION MENU screen. This is set to 9600 BAUD at the factory.)
- Communication format: Start: 1 bit
Data: 8 bits
Parity: None
Stop: 1 bit
- Communication codes: Two types, the ASCII and display character codes

ASCII code

The codes with diagonal line are not used.

	0	1	2	3	4	5	6	7	8	9	A	B	C	D	E	F
0	/	/	S _x	E _x	/	/	/	/	/	/	/	/	/	/	/	/
1	/	/	/	/	/	/	/	/	/	/	/	/	/	/	/	/
2	(blank)	!	/	/	/	/	/	/	/	/	*	/	,	-	/	/
3	0	1	2	3	4	5	6	7	8	9	:	/	<	/	>	?
4	/	A	B	C	D	E	F	G	H	I	J	K	L	M	N	O
5	/	P	Q	R	S	T	U	V	W	X	Y	Z	/	/	/	/
6	/	/	/	/	/	/	/	/	/	/	/	/	/	/	/	/
7	/	/	/	/	/	/	/	/	/	/	/	/	/	/	/	/

Display character code

The codes with diagonal line are not used.

	0	1	2	3	4	5	6	7	8	9	A	B	C	D	E	F
0	/	/	/	/	/	/	/	/	/	/	/	/	/	/	/	/
1	/	/	/	/	/	/	/	/	/	/	/	/	/	/	/	/
2	(blank)	/	"	/	\$	%	&	'	()	*	+	,	-	.	/
3	0	1	2	3	4	5	6	7	8	9	:	;	/	=	/	?
4	/	A	B	C	D	E	F	G	H	I	J	K	L	M	N	O
5	/	P	Q	R	S	T	U	V	W	X	Y	Z	/	/	/	/
6	/	a	b	c	d	e	f	g	h	i	j	k	l	m	n	o
7	/	p	q	r	s	t	u	v	w	x	y	z	/	/	/	/

■ Communication Protocol

- Be sure to attach an "SX" code at the start of communications and an "EX" code at the end. The VCR does not accept the command without these codes.
- The VCR only transmits a reply to the received command.
- When the VCR receives one of the remote control commands shown on page 25, it returns the status for reception acknowledgment or the status requested currently.
- If the commands are transmitted consecutively or another command is transmitted before the VCR has ended an operation, the VCR returns the "SX"BUSY"EX" code. Re-transmit the command.
- If there is a mistake in the received communications format, the VCR returns one of the following communication error codes.
 - ERL: Error in code length
 - ERC: Error in code format
 - ERT: Error inside the VCR (when return is not possible within about 2 seconds)
- When the VCR detects a communications error such as a stop bit error, bit length error, etc., it replaces the received byte with "!" for processing.
 - * If a communications error occurs in the OSD display data, the OSD character is replaced with "!". If a communications error occurs in data other than the above, a communications error code is returned.

■ OSD Display Data

When the date and hour are displayed or nothing is displayed (only the picture is displayed), up to 12 characters are displayed at the position shown in the figure.

Up to 12 characters are displayed at this position.

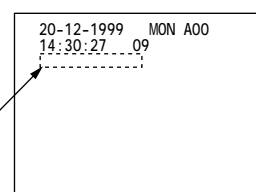

OPERATING THE VCR FROM A PERSONAL COMPUTER (Continued)

■ Format of Commands and Status

See pages 26 and 27 for the meanings of the small letters in the table.

	Function of command	Format of command	Status for reception acknowledgment
	Stop	$s_xSTO^E_x$	$s_xSTO^E_x$ i
	Fast forward	$s_xFWD^E_x$	$s_xFWD^E_x$ u
	Rewind	$s_xREW^E_x$	$s_xREW^E_x$ y Operates the VCR in the same
	Recording	$s_xREC^E_x$	$s_xREC^E_x$ u way as when its buttons
	Playback	$s_xFPL^E_x$	$s_xFPL^E_x$ u are pressed.
	Reverse play	$s_xRPL^E_x$	$s_xRPL^E_x$ u
	Frame advance	$s_xFAD^E_x$	$s_xFAD^E_x$ u
	Reverse frame advance	$s_xRAD^E_x$	$s_xRAD^E_x$ u
	Pause/still play	$s_xPAU^E_x$	$s_xPAU^E_x$ u
	Pause/still play ON	$s_xPA1^E_x$	$s_xPA1^E_x$ u
	Pause/still play OFF	$s_xPA0^E_x$	$s_xPA0^E_x$ u
	Tape eject	$s_xEJE^E_x$	$s_xEJE^E_x$ t
	One shot input	$s_xOSR^E_x$	$s_xOSR^E_x$ Controls pin ③.
	Alarm index ON/OFF	$s_xAlw^E_x$	$s_xAlw^E_x$ i
	Timer ON/OFF	$s_xTSS^E_x$	$s_xTSS^E_x$ y Operates the VCR in the same
	Mode lock ON/OFF	$s_xMLI^E_x$	$s_xMLI^E_x$ u way as when its buttons
	Alarm reset	$s_xAL^-E_x$	$s_xAL^-E_x$ u are pressed.
	Counter reset	$s_xCO^-E_x$	$s_xCO^-E_x$ t
	Tape end reset	$s_xTE^-E_x$	$s_xTE^-E_x$ Controls pin ⑤.
	System control microprocessor reset	$s_xSY^-E_x$	
Remote operation	Tape speed	s_xSPD r ^E _x	$s_xSPD^E_x$ Specifies the recording/playback mode.
	OSD screen number	s_xSCR n ^E _x	$s_xSCR^E_x$
	OSD horizontal display position up	$s_xHO>^E_x$	$s_xHO>^E_x$
	OSD horizontal display position	s_xHOR jj ^E _x	$s_xHOR^E_x$
	OSD vertical display position up	$s_xVE>^E_x$	$s_xVE>^E_x$
	OSD vertical display position	s_xVER vv ^E _x	$s_xVER^E_x$
	TIME ADJUST	$s_xTA\eta^E_x$	$s_xTA\eta^E_x$
	ONE SHOT REC	$s_xORF^E_x$	$s_xORF^E_x$ i
	SEARCH SPEED	$s_xSXx^E_x$	$s_xSXx^E_x$ y Settings on the SELECTION
	VIDEO MODE	$s_xVMk^E_x$	$s_xVMk^E_x$ u MENU screen.
	CAMERA SW	s_xCSW z ^E _x	$s_xCSW^E_x$ t
	Buzzer setting	s_xBZR β, γ, δ, ε, ζ ^E _x	$s_xBZR^E_x$
	Clock setting	s_xCLK yy-mm-dd, hh:ff, www ^E _x	$s_xCLK^E_x$ Specifies the current time.
	Alarm recording setting	s_xALA ddd, r, u, o, qq ^E _x	$s_xALA^E_x$ Sets the alarm recording conditions.
	Program setting	s_xPRp hh:ff, hh:ff, r ^E _x	$s_xPRp^E_x$ Sets a timer program.
	Timer setting	s_xwww p, p ^E _x	$s_xwww^E_x$ Selects the timer program on each day of the week.
	OSD display	s_xOSD αααααααααααααα ^E _x	$s_xOSD^E_x$ Command to display characters.

	Function of command	Format of command	Status for reception acknowledgment
Status check	VCR running status	$^S_xVCR ?^{E_x}$	S_xVCR bbb, s, w, l, v, a E_x i
	Tape speed	$^S_xSPD ?^{E_x}$	S_xSPD Nr E_x u
	Cassette status	$^S_xCAS ?^{E_x}$	S_xCAS N, b, ttt E_x u
	Time	$^S_xCLK ?^{E_x}$	S_xCLK yy-mm-dd, hh:ff:ss, www E_x u
	Alarm count	$^S_xALC ?^{E_x}$	S_xALC aa E_x u
	Alarm setting information	$^S_xALA ?^{E_x}$	S_xALA ddd, r, u, o, qqqq E_x u
	Alarm memory information	$^S_xALq ?^{E_x}$	S_xALq yy-mm-dd, hh:ff:ss E_x u
	Program setting information	$^S_xPRp ?^{E_x}$	S_xPRp hh:ff, hh:ff, r E_x y Status
	Timer setting information	$^S_xwww ?^{E_x}$	S_xwww p, p E_x u formats
	Counter value	$^S_xCTR ?^{E_x}$	S_xCTR ccccc E_x u
	OSD display picture	$^S_xSCR ?^{E_x}$	S_xSCR n E_x u
	OSD setting values	$^S_xOSD ?^{E_x}$	S_xOSD jj, vv, W E_x u
	Various setting values	$^S_xSET ?^{E_x}$	S_xSET x, f, C, A, A, k, 0, z E_x u
	Buzzer setting values	$^S_xBZR ?^{E_x}$	S_xBZR β , γ , δ , ϵ , ζ E_x u
	Time adjust	$^S_xTAD ?^{E_x}$	S_xTAD η E_x u
	Total time of use	$^S_xTOT ?^{E_x}$	S_xTOT xxxxx, zzzzz E_x u
	Tape end signal	$^S_xEND ?^{E_x}$	S_xEND e, g E_x t

■ Details of Small Letters

Symbol	Identification	Type of code	Details of code
a	Alarm yes/no	ASCII	1: Alarm input, 0: No alarm
aa	Number of alarms	ASCII	2-digit number (00-99 or E0-E9)
b	Safety tab on cassette	ASCII	1: Tab, 0: No tab
bbb	Running status	ASCII	Three letters STO: Stop FPL: Playback REC: Recording STI: Still RAD: Reverse frame advance REW: Rewind FWD: Fast forward REV: Reverse search CUE: Forward search RPL: Reverse play FAD: Frame advance AIS: Alarm index search
ccc	Counter value	ASCII	5-digit number (00000-99999)
dd	Day	ASCII	2-digit number (01-31)
ddd	ALARM DURATION	ASCII	Three letters or two numerals and one letter MAN: Manual, 05S: 5 s, 15S: 15 s, 30S: 30 s, 01M: 1 min, 03M: 3 min, 05M: 5 min, 10M: 10min, 30M: 30 min, 60M: 60 min, END: TAPE END
e	Tape end output (2)	ASCII	1: high, 0: low
f	ONE SHOT REC	ASCII	2, 4, 6, 8: Number of fields (in recording)
ff	Minute	ASCII	2-digit number (00-59)
g	Tape end output	ASCII	1: high, 0: low
hh	Hour	ASCII	2-digit number (00-23)
jj	Horizontal display start position	ASCII	2-digit number (03-21)
k	VIDEO MODE	ASCII	A: AUTO, B: B/W, C: COLOUR
l	Mode lock	ASCII	1: ON, 0: OFF

OPERATING THE VCR FROM A PERSONAL COMPUTER (Continued)

Symbol	Identification	Type of code	Details of code
mm	Month	ASCII	2-digit number (01~12)
n	OSD screen	ASCII	one numeral or one letter (0~6, A, B) 0: Various data display (FULL) 1: Various data display (HALF) 2: Timer programming 3: Mode selection 4: Alarm record setting or recycle functions 5: Alarm memory 6: Display off A: Buzzer selection B: Clock set
o	ALARM OUT	ASCII	D: Duration, P: Pulse
p	Timer program number	ASCII	One-digit number (1~7) or *
q	Alarm memory number	ASCII	One-digit number (1~9)
qqqq	RECYCLE FUNC.	ASCII	4 letters ALRM: REWIND, STOP IF ALARM RWND: REWIND, STOP RREC: REWIND, RE-REC
r	Tape speed	ASCII	One numeral or one letter (0~8, E) 0: 09, 1: 27, 4: 48, 5: 72, 6: 120, 7: 168, 8: 240, E: 00
s	Timer standby	ASCII	1: ON, 0: OFF
ss	Second	ASCII	2-digit number (00~59)
ttt	Tape status	ASCII	Three letters NTP: No cassette, END: End of tape, BGN: Start of tape, NRM: Normal status
u	ALARM READY	ASCII	Y: Yes, N: No
v	Power failure yes/no	ASCII	1: Power failure, 0: No power failure
vv	Vertical display start position	ASCII	2-digit number (02~22)
w	Alarm index	ASCII	1: ON, 0: OFF
www	Day of the week	ASCII	Three letters SUN: Sunday, MON: Monday, TUE: Tuesday, WED: Wednesday, THU: Thursday, FRI: Friday, SAT: Saturday
x	SEARCH SPEED	ASCII	3, 5, 7, 9: Search speed ratio
xxxxx	Head usage time	ASCII	5-digit number (00000~99999)
yy	Year	ASCII	2-digit number (00~99)
z	CAMERA SW	ASCII	2: 09, 0: 27~, 1: ALL
zzzzz	Total time of use	ASCII	5-digit number (00000~99999)
α	OSD characters	Display characters	See the display character code table on page 24.
β	TAPE END buzzer	ASCII	1=ON 0=OFF
γ	TROUBLE buzzer	ASCII	1=ON 0=OFF
δ	NO VIDEO buzzer	ASCII	1=ON 0=OFF
ϵ	REC CHECK buzzer	ASCII	1=ON 0=OFF
ζ	ALARM OUT buzzer	ASCII	1=ON 0=OFF
η	TIME ADJUST	ASCII	1=MASTER 0=SLAVE

PROBLEM GUIDE

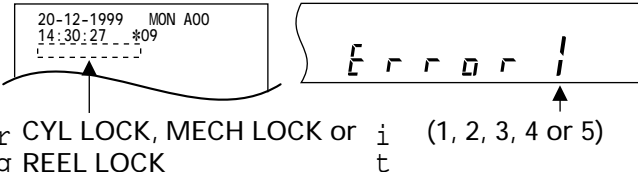
If you are having this kind of trouble:	Check these things:
<ul style="list-style-type: none"> ■ No power (No indicators ON) 	<ul style="list-style-type: none"> □ Check to see if unit is plugged in. (Power at supply outlet?)
<ul style="list-style-type: none"> ■ Recorder fails to respond to user command/operation 	<ul style="list-style-type: none"> □ Perform MASTER SYSTEM RESET. See page 22.
<ul style="list-style-type: none"> ■ No monitor picture 	<ul style="list-style-type: none"> □ Carefully check monitor/VCR/camera connectors.
<ul style="list-style-type: none"> ■ Poor picture during monitor viewing (in the RECORD or STOP mode) 	<ul style="list-style-type: none"> □ Check monitor/camera adjustments.
<ul style="list-style-type: none"> ■ Black streaks on picture during 09 or 27 mode playback 	<ul style="list-style-type: none"> □ Adjust the TRACKING control (may need to be returned to center position if previously adjusted). The TRACKING control is only active for the 09 or 27 mode. □ Replace cassette. □ Clean video heads.
<ul style="list-style-type: none"> ■ Recording or playback cannot be done 	<ul style="list-style-type: none"> □ Remove cassette and reinsert. □ Check the LOCK indicator on the front panel. If the indicator is lit, press both SET and DOWN buttons simultaneously to release the security lock.
<ul style="list-style-type: none"> ■ RECORD functions not operate 	<ul style="list-style-type: none"> □ Check the TAB indicator is lit. □ See Note on page 12.
<ul style="list-style-type: none"> ■ PLAY function not operate 	<ul style="list-style-type: none"> □ Be sure there is a cassette in the unit.
<ul style="list-style-type: none"> ■ Extreme noise appears on the playback picture 	<ul style="list-style-type: none"> □ Video heads require cleaning.
<ul style="list-style-type: none"> ■ TIME/DATE information not displayed on the MONITOR 	<ul style="list-style-type: none"> □ Select FULL or HALF with OSD TYPE in [OPTIONS]. See page 15.
<ul style="list-style-type: none"> ■ TIMER recording was not done 	<ul style="list-style-type: none"> □ TIMER may not have been set properly. □ Check for SAFETY TAB of cassette. □ TIME and DATE are not correct. □ Cassette tape length may have been exceeded. Multiple ALARMS used up tape.
<ul style="list-style-type: none"> ■ REWIND or FAST FORWARD does not operate 	<ul style="list-style-type: none"> □ Tape may already be rewound or be at the end of tape.
<ul style="list-style-type: none"> ■ Unable to SELECT/CHANGE program feature 	<ul style="list-style-type: none"> □ Check the LOCK indicator on the front panel. If the indicator is lit, press both SET and DOWN buttons simultaneously to release the security lock.
<ul style="list-style-type: none"> ■ The VCR does not operate if an operation button is pressed 	<ul style="list-style-type: none"> □ Press the EJECT button to remove the cassette, then restart VCR operations.
<ul style="list-style-type: none"> ■ Buzzer sounds 	<ul style="list-style-type: none"> □ You have specified the buzzer to sound when abnormality has occurred. See page 18.
<ul style="list-style-type: none"> ■ An error appears in the display  <p>r CYL LOCK, MECH LOCK or q REEL LOCK</p> <p>(1, 2, 3, 4 or 5)</p>	<ul style="list-style-type: none"> □ Unplug the power cord and plug it in again. □ Press the reset button marked "S". <p>Note: If the VCR does not recover by these operations, consult your dealer.</p>

SPECIFICATIONS

Video Cassette:	VHS type
Recording:	Rotary two-head helical scan azimuth recording
Tape Speed:	7.8 mm/sec. (09 mode)
Tape Width:	12.7 mm
Operation Temperature:	5°C to 40°C
Video:	PAL colour (system I) & CCIR monochrome signals (625 lines)
Recording Lengths:	09, 27, 48, 72, 120, 168, 240 hours and ONE SHOT (00 mode)
Video Input:	1 Vp-p 75 ohm unbalanced
Video Output:	1 Vp-p 75 ohm unbalanced
S/N Ratio (Video):	More than 40 dB (09 mode)
S/N Ratio (Audio):	More than 40 dB (09 mode)
Horizontal Resolution:	Colour: 300 lines (09 mode) Monochrome: 350 lines (09 mode)
Audio Input:	-8 dBm 50 Kohm unbalanced
Audio Output:	-9 dBm 600 ohm unbalanced
Audio Frequency Range:	100 Hz to 3 kHz (09 mode)
Power:	AC 230V, 50 Hz
Power Consumption:	23W
Cabinet Size:	435 mm (W) x 94 mm (H) x 366 mm (D)
Weight:	Approx. 6.2 kg

* Design and specifications are subject to change without notice.

Maintenance

Two periodic maintenance steps are recommended to insure the peak performance of this products.

1. Periodically make a careful observation of the quality of the playback video. If there are excessive dropouts (noise specks) across the video picture, and the TRACKING control does not clear the picture, then head cleaning may be necessary. Obtain a high quality head cleaning kit, and follow the directions carefully. The length of time between cleaning depends on the amount of airborne contaminates around the tape recorder and/or cassette.
2. The unit should be inspected every 3500 hours of continuous usage by the dealer from whom the recorder was purchased.

SOME DO'S AND DON'TS ON THE SAFE USE OF EQUIPMENT

This equipment has been designed and manufactured to meet international safety standards but, like any electrical equipment, care must be taken if you are to obtain the best results and safety is to be assured.

★★★★★★★★★★

DO read the operating instructions before you attempt to use the equipment.

DO ensure that all electrical connections (including the mains plug, extension leads and interconnections between pieces of equipment) are properly made and in accordance with the manufacturer's instructions. Switch off and withdraw the mains plug when making or changing connections.

DO consult your dealer if you are ever in doubt about the installation, operation or safety of your equipment.

DO be careful with glass panels or doors on equipment.

★★★★★★★★★★

DON'T continue to operate the equipment if you are in any doubt about it working normally, or if it is damaged in any way — switch off, withdraw the mains plug and consult your dealer.

DON'T remove any fixed cover as this may expose dangerous voltages.

DON'T leave equipment switched on when it is unattended unless it is specifically stated that it is designed for unattended operation or has a standby mode. Switch off using the switch on the equipment and make sure that your family know how to do this. Special arrangements may need to be made for infirm or handicapped people.

DON'T use equipment such as personal stereos or radios so that you are distracted from the requirements of traffic safety. It is illegal to watch television whilst driving.

DON'T listen to headphones at high volume, as such use can permanently damage your hearing.

DON'T obstruct the ventilation of the equipment, for example with curtains or soft furnishings. Overheating will cause damage and shorten the life of the equipment.

DON'T use makeshift stands and **NEVER** fix legs with wood screws — to ensure complete safety always fit the manufacturer's approved stand or legs with the fixings provided according to the instructions.

DON'T allow electrical equipment to be exposed to rain or moisture.

ABOVE ALL

- **NEVER** let anyone especially children push anything into holes, slots or any other opening in the case — this could result in a fatal electrical shock;
- **NEVER** guess or take chances with electrical equipment of any kind
- **it is better to be safe than sorry!**

★★★★★★★★★★



Time-lapse Video Recorder

Instructions for Use



Eng

F

E

LTC 3963/61

IMPORTANT SAFEGUARDS

1. Read Instructions — All the safety and operating instructions should be read before the unit is operated.
2. Retain Instructions — The safety and operating instructions should be retained for future reference.
3. Heed Warnings — All warnings on the unit and in the operating instructions should be adhered to.
4. Follow Instructions — All operating and use instructions should be followed.
5. Cleaning — Unplug the unit from the outlet before cleaning. Do not use liquid cleaners or aerosol cleaners. Use a damp cloth for cleaning.
6. Attachments — Do not use attachments not recommended by the product manufacturer as they may cause hazards.
7. Water and Moisture — Do not use this unit near water – for example, near a bath tub, wash bowl, kitchen sink, or laundry tub, in a wet basement, near a swimming pool, in an unprotected outdoor installation, or any area which is classified as a wet location.
8. Accessories — Do not place this unit on an unstable stand, tripod, bracket, or mount. The unit may fall, causing serious injury to a person and serious damage to the unit. Use only with a stand, tripod, bracket, or mount recommended by the manufacturer, or sold with the product. Any mounting of the unit should follow the manufacturer's instructions, and should use a mounting accessory recommended by the manufacturer.

An appliance and cart combination should be moved with care. Quick stops, excessive force, and uneven surfaces may cause the appliance and cart combination to overturn.



9. Ventilation — Openings in the enclosure, if any, are provided for ventilation and to ensure reliable operation of the unit and to protect it from overheating. These openings must not be blocked or covered. This unit should not be placed in a built-in installation unless proper ventilation is provided or the manufacturer's instructions have been adhered to.
10. Power Sources — This unit should be operated only from the type of power source indicated on the marking label. If you are not sure of the type of power supply you plan to use, consult your appliance dealer or local power company. For units intended to operate from battery power, or other sources, refer to the operating instructions.
11. Grounding or Polarization — This unit may be equipped with a polarized alternating-current line plug (a plug having one blade wider than the other). This plug will fit into the power outlet only one way. This is a safety feature. If you are unable to insert the plug fully into the outlet, try reversing the plug. If the plug should still fail to fit, contact your electrician to replace your obsolete outlet. Do not defeat the safety purpose of the polarized plug.

Alternately, this unit may be equipped with a 3-wire grounding-type plug, a plug having a third (grounding) pin. This plug will only fit into a grounding-type power outlet. This is a safety feature. If you are unable to insert the plug into the outlet, contact your electrician to replace your obsolete outlet. Do not defeat the safety purpose of the grounding-type plug.

12. Power-Cord Protection — Power-supply cords should be routed so that they are not likely to be walked on or pinched by items placed upon or against them, paying particular attention to cords and plugs, convenience receptacles, and the point where they exit from the appliance.
13. Power Lines — An outdoor system should not be located in the vicinity of overhead power lines or other electric light or power circuits, or where it can fall into such power lines or circuits. When installing an outdoor system, extreme care should be taken to keep from touching such power lines or circuits as contact with them might be fatal. U.S.A. models only – refer to the National Electrical Code Article 820 regarding installation of CATV systems.
14. Overloading — Do not overload outlets and extension cords as this can result in a risk of fire or electric shock.
15. Object and Liquid Entry — Never push objects of any kind into this unit through openings as they may touch dangerous voltage points or short-out parts that could result in a fire or electric shock. Never spill liquid of any kind on the unit.
16. Servicing — Do not attempt to service this unit yourself as opening or removing covers may expose you to dangerous voltage or other hazards. Refer all servicing to qualified service personnel.

17. Damage Requiring Service — Unplug the unit from the outlet and refer servicing to qualified service personnel under the following conditions.
 - a. When the power-supply cord or plug is damaged.
 - b. If liquid has been spilled, or objects have fallen into the unit.
 - c. If the unit has been exposed to rain or water.
 - d. If the unit does not operate normally by following the operating instructions. Adjust only those controls that are covered by the operating instructions, as an improper adjustment of other controls may result in damage and will often require extensive work by a qualified technician to restore the unit to its normal operation.
 - e. If the unit has been dropped or the cabinet has been damaged.
 - f. When the unit exhibits a distinct change in performance – this indicates a need for service.
18. Replacement Parts — When replacement parts are required, be sure the service technician has used replacement parts specified by the manufacturer or have the same characteristics as the original part. Unauthorized substitutions may result in fire, electric shock or other hazards.
19. Safety Check — Upon completion of any service or repairs to this unit, ask the service technician to perform safety checks to determine that the unit is in proper operating condition.
20. Coax Grounding — If an outside cable system is connected to the unit, be sure the cable system is grounded. U.S.A. models only – Section 810 of the National Electrical Code, ANSI/NFPA No. 70-1981, provides information with respect to proper grounding of the mount and supporting structure, grounding of the coax to a discharge unit, size of grounding conductors, location of discharge unit, connection to grounding electrodes, and requirements for the grounding electrode.
21. Lightning — For added protection of this unit during a lightning storm, or when it is left unattended and unused for long periods of time, unplug it from the wall outlet and disconnect the cable system. This will prevent damage to the unit due to lightning and power-line surges.

FCC & ICES INFORMATION (U.S.A. and Canadian Models Only)

WARNING — This equipment has been tested and found to comply with the limits for a Class B digital device, pursuant to Part 15 of the FCC Rules and ICES-003 of Industry Canada. These limits are designed to provide reasonable protection against harmful interference when the equipment is operated in a residential installation. This equipment generates, uses and can radiate radio frequency energy and, if not installed and used in accordance with the instructions, may cause harmful interference to radio communications. However, there is no guarantee that interference will not occur in a particular installation. If this equipment does cause harmful interference to radio or television reception, which can be determined by turning the equipment off and on, the user is encouraged to try to correct the interference by one or more of the following measures:

- Reorient or relocate the receiving antenna.
- Increase the separation between the equipment and receiver.
- Connect the equipment into an outlet on a circuit different from that to which the receiver is connected.
- Consult the dealer or an experienced radio/TV technician for help.

Intentional or unintentional changes or modifications not expressly approved by the party responsible for compliance shall not be made. Any such changes or modifications could void the user's authority to operate the equipment.

This Class B digital apparatus meets all requirements of the Canadian Interference-Causing Equipment Regulations.

The user may find the following booklet prepared by the Federal Communications Commission helpful: "How to Identify and Resolve Radio-TV Interference Problems". This booklet is available from the U.S. Government Printing Office, Washington, DC 20402, Stock No. 004-000-00345-4.

SAFETY PRECAUTIONS

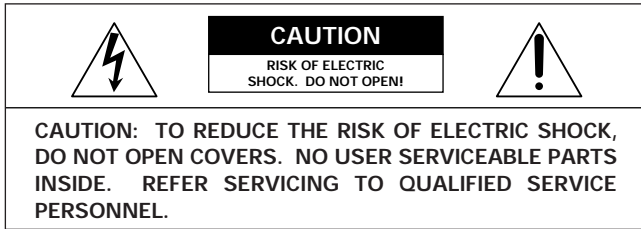

This label may appear on the bottom of the unit due to space limitations.

 The lightning flash with an arrowhead symbol, within an equilateral triangle, is intended to alert the user to the presence of uninsulated "dangerous voltage" within the product's enclosure that may be of sufficient magnitude to constitute a risk of electric shock to persons.

 The exclamation point within an equilateral triangle is intended to alert the user to presence of important operating and maintenance (servicing) instructions in the literature accompanying the appliance.

WARNING

To prevent fire or shock hazard, do not expose units not specifically designed for outdoor use to rain or moisture.

 **Attention:** Installation should be performed by qualified service personnel only in accordance with the National Electrical Code or applicable local codes.

 **Power Disconnect:** Units with or without ON-OFF switches have power supplied to the unit whenever the power cord is inserted into the power source; however, the unit is operational only when the ON-OFF switch is in the ON position. The power cord is the main power disconnect for all units.

 **External Power Supplies**
Use Only the Recommended Power Supplies. Power supplies must comply with the requirements of the latest version of IEC 65/VDE 0860. Substitutions may damage the unit or cause a fire or shock hazard.

220-240 V, 50 Hz Power Cords

 220-240 V, 50 Hz power cords, input and output, must comply with the latest versions of IEC Publication 227 or IEC Publication 245.



WARNING: Electrostatic-sensitive device. Use proper CMOS/MOSFET handling precautions to avoid electrostatic discharge.

NOTE: Grounded wrist straps must be worn and proper ESD safety precautions observed when handling the electrostatic-sensitive printed circuit boards.

1 UNPACKING

Unpack carefully. This is electronic equipment and should be handled carefully.

Check to ensure that the following items are included:

- Model number of unit.

If an item appears to have been damaged in shipment, replace it properly in its carton and notify the shipper. If any items are missing, notify your Philips Communication & Security Systems Inc. Sales Representative or Customer Service.

The shipping carton is the safest container in which the unit may be transported. Save it for possible future use.

2 SERVICE

If the unit ever needs repair service, the customer should contact the nearest Philips Communication & Security Systems Inc. Service Center for return authorization and shipping instructions.

Service Centers

U.S.A. & Canada: 800-366-2283

Mexico & Central America: 52-5-564-2726

Europe & Middle East: 44-1932-765666

South America: 54-1-956-0837

Australia: 61-2-888-9000

New Zealand: 64-4-237-7297

3 DESCRIPTION

4 INSTALLATION

FEATURES

Recording

- High Density Time-Lapse Video Recorder
- Nine Touch-Selectable Recording Speeds
- Automatic "Alarm-Command" Speed Up
- Recording Check
- One Shot Recording
- On-Screen and On-Tape Time/Date Information
- 7-Day Programmable On/Off Timer
- "Alarm On" Output
- Usable Audio at 06, A18 and A30 Hour Speeds
- RS-232C Interface Connector

Playback

- Time-of-Alarm Memory and Alarm Index Search
- High Speed Visual Search
- Nine Playback Speeds
- Still Field, Field-Advance, Field-Reverse and Reverse Playback

Security

- About 720 Hours Memory Protection
- Electronic Security Lockout

Note: This recorder has a rechargeable battery to maintain display functions and recording mode within 720 hours in the event of power loss. When the recorder is received, the unit must be connected to power source for 48 hours to assure the battery has been adequately charged.

CONTENTS

IMPORTANT SAFEGUARDS	1
SAFETY PRECAUTIONS	2
PRECAUTIONS	4
CONTROLS AND FUNCTIONS	5
INSTALLATION	9
EXTERNAL CONNECTIONS	10
CASSETTE TAPES	12
SETUP	13
SETTING THE TIME AND DATE	14
SETTING [OPTIONS] ITEMS	15
SUMMER TIME FUNCTION	15
SETTING THE TIMER	15
SETTING THE VCR FUNCTIONS	17
SETTING THE BUZZER	18
SETTING THE ALARM	19
ALARM MEMORY RECALL AND RESET	20
OPERATION	21
TAPE RECORDING	21
REC CHECK	21
AUTO REC CHECK	21
ONE SHOT RECORDING	21
TIMER RECORDING	21
TAPE RECYCLE	21
ALARM RECORDING	22
MASTER SYSTEM RESET	22
PLAYBACK	22
STILL PLAYBACK	22
V.LOCK ADJUST	22
PLAYBACK IN THE FIELD ADVANCE/ REVERSE MODES	22
VISUAL SEARCH (High Speed Scan)	22
ALARM INDEX SEARCH	23
TO SECURE THE VCR	23
OPERATING THE VCR FROM A PERSONAL COMPUTER	24
PROBLEM GUIDE	28
SPECIFICATIONS	29

Auto Head Cleaning System

This system cleans the video heads automatically when a cassette is inserted and ejected or the tape is rewound in the recycle recording mode, to prevent dirt from accumulating on the heads.

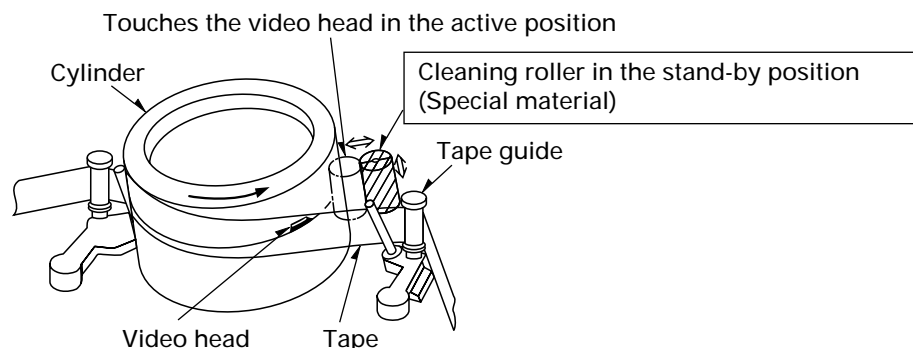

PRECAUTIONS

Safety

- Should any solid object or liquid fall into the cabinet, turn off the unit and have it checked by qualified personnel before operating it any further.
- To disconnect the mains lead, pull it out by the plug. Never pull the lead itself.

Installation

- Choose a location in which air can pass through the ventilation holes in the bottom, top and back of the unit to prevent it from overheating.
- Do not install the unit near heat sources such as radiators or air ducts or in a place subject to direct sunlight, excessive dust, mechanical vibrations or shock.
- Do not place heavy objects or heat-generating objects on the VCR, or the cabinet could be damaged or the temperature inside the VCR could rise, which could cause a fault.
- Never bring a magnet or magnetized object near the VCR because it will adversely affect the performance of the VCR.
- Do not install the unit in an inclined position. The unit is designed for operation in a horizontal position.

Operation

- Condensation
If you pour a cold liquid into a glass, water vapor in the air will condense on the surface of the glass.
This is the condensation of moisture.
Condensation on the head drum, one of the most crucial parts of the VCR, will cause damage to the tape. The VCR should not be operated for at least 2 hours after being moved from a cold to a hot environment to avoid condensation from occurring on the head drum.

Cleaning

- Be careful; when the surface of the case is wiped with a volatile agent such as benzine, alcohol, thinner, etc., or a chemically processed cloth, the surface finish may be degraded or its coating may peel off.

Repacking

- It is wise to save the packing materials and box in case you ever need to ship or store your unit.

CONTROLS AND FUNCTIONS

[FRONT]

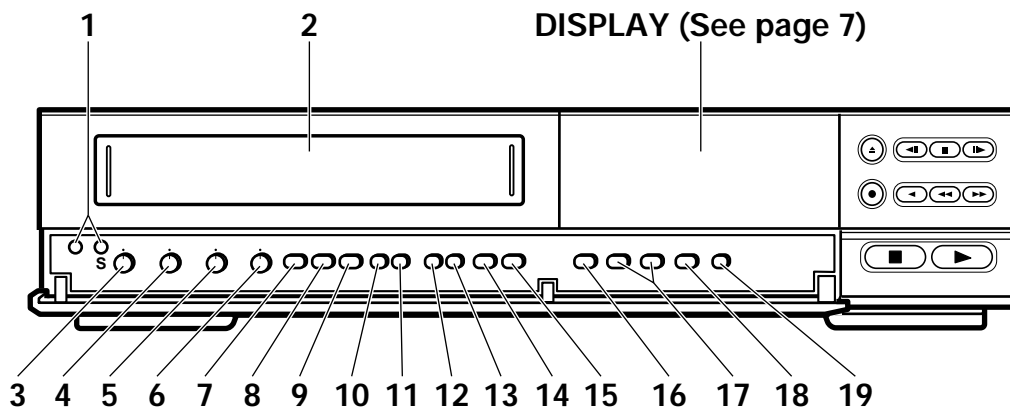

1. RESET BUTTONS

Press these buttons at the same time to clear all (microprocessor) functions.
Press the "S" button to reset the system. (This does not erase the stored information.)

2. CASSETTE COMPARTMENT

3. SHARPNESS CONTROL

Adjust the picture quality to hard or soft during playback.

4. TRACKING CONTROL

Adjust to optimize the picture quality during playback at the 06, A18 and A30 hour speeds.

5. SLOW TRACKING CONTROL

Adjust to optimize the picture quality in the SLOW PLAY mode, e.g. speeds over 30 hours.

6. V. LOCK CONTROL

Reduces vertical jitter in the still play mode.

7. PROGRAM BUTTON

Press to select one of the six programmable functions.

8. START/STOP BUTTON

Press to start or stop the programming of a programmable function. (Press once to start the programming sequence and a second time to stop (end) it.)

9. SET BUTTON

Press to select the specific value which is to be changed with the UP/DOWN buttons.

10. DOWN BUTTON

Press to decrement, change or reverse to the previous/lower value.

11. UP BUTTON

Press to increase, change or advance to the next higher value.

12. V-POS (VERTICAL POSITION) BUTTON

Press repeatedly to control the vertical position of the programmable display on the monitor.

13. H-POS (HORIZONTAL POSITION) BUTTON

Press repeatedly to control the horizontal position of the programmable display on the monitor.

14. ALARM INDEX BUTTON

Press this button to cause the INDEX indicator to light, and set the VCR to the visual search mode (press F.FWD or REWIND during playback mode) in this state; the start of the alarm recorded can be located.

15. ALARM RESET BUTTON

Press to clear POWER LOSS information. When this button is pressed, the alarm memory is cleared.

16. COUNTER RESET BUTTON

Press to clear the digital counter to "00000".

17. REC/PLAY HOURS BUTTONS

▲ (UP): Press to increase hours to the next higher value.

▼ (DOWN): Press to decrease hours to the next lower value. The tape speed will be indicated as part of the monitor display.

18. TIMER BUTTON

Press after programming the TIMER for automatic TIMER recording. See page 15 for TIMER programming.

19. SUMMER TIME BUTTON

Press to set the summer time. See "SUMMER TIME FUNCTION" on page 15 for details.

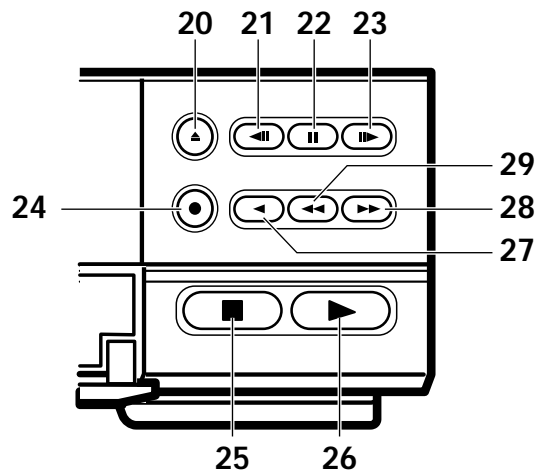

20. EJECT BUTTON

Press to remove the cassette. The EJECT button will not operate in the RECORD mode.

21. FIELD REVERSE BUTTON

Press to reverse the tape by one field in the STILL playback mode.

22. STILL BUTTON

Press to momentarily stop tape motion in the play mode. The STILL function allows close inspection of individual scenes. See the description of STILL playback on page 22.

23. FIELD ADVANCE BUTTON

Press to advance the tape one field in the STILL playback mode.

24. RECORD BUTTON

Press to start recording.

25. STOP BUTTON

Press to stop the tape. The STOP button must be pressed to end the RECORD and PLAY mode.

26. PLAY BUTTON

Press to play recorded material in the forward direction. Pressing this during recording makes it possible to check recordings.

27. REVERSE PLAY BUTTON

Press to play recorded material at the 06, 72, 120, 168 or 240 speed in the reverse direction during the PLAY mode.

28. FAST FORWARD/VISUAL SEARCH BUTTON

Press to activate fast forward. Press this button during playback and a forward playback picture at high speed can be seen.

29. REWIND/VISUAL SEARCH BUTTON

Press to start rewind. Press this button during playback and a reverse playback picture at high speed can be seen.

CONTROLS AND FUNCTIONS (Continued)

[DISPLAY]

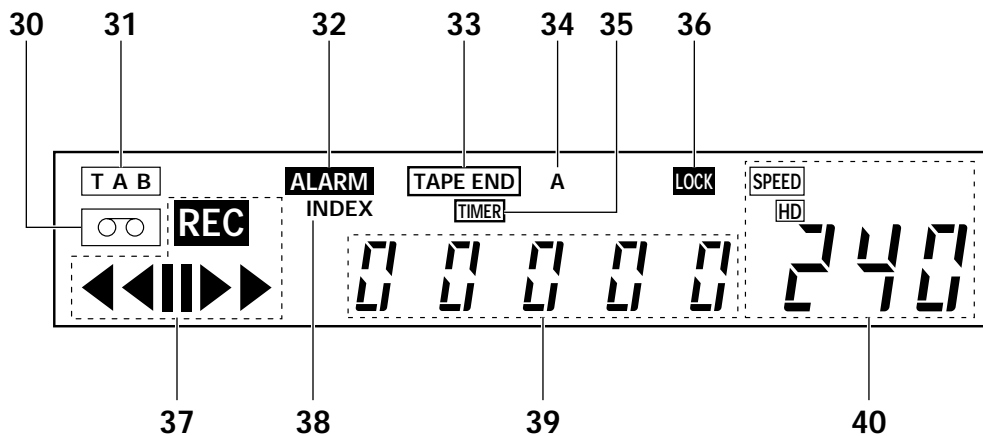

30. TAPE-IN INDICATOR

Lights when a cassette is in the compartment.

31. TAB INDICATOR

Lights when a cassette without its safety tab is loaded.

32. ALARM INDICATOR

ALARM appears during alarm recording.
ALARM flashes when alarm recording ends.

33. TAPE END INDICATOR

Lights when the tape reaches the end during recording.

Note: "TAPE END" is not displayed when you have selected REWIND, RE-REC in the "RECYCLE FUNCTIONS" menu in the alarm display or you have selected REWIND, STOP IF ALARM but an alarm recording has not been made.

34. A INDICATOR

Lights when no video signal is input. Video signal input will turn this indicator off automatically.

35. TIMER INDICATOR

This is lit during timer recording or TIMER stand-by mode.

The indicator flashes in the following cases.

- A cassette is not loaded.
- A cassette without its safety tab is loaded.
- The timer has not been programmed.

36. LOCK INDICATOR

LOCK appears when the recorder is in the security lock mode.

37. VCR MODE INDICATORS

- **REC** appears during recording.
- **◀◀** appears during the rewind mode.
- **▶▶** appears during the fast forward mode.
- **◀◀** (or **▶▶**) flashes during visual search.
- **▶** appears during the playback mode.
- **◀** appears during the reverse play mode.
- **||** appears when the STILL button is pressed during play mode and disappears when the STILL or PLAY button is pressed again.
- **◀||** (or **||▶**) appears while the FIELD REV (or FIELD ADV) is held depressed in the still playback mode.

Note: Still playback is restored when the FIELD REV (or FIELD ADV) button is released.

38. INDEX INDICATOR

INDEX appears when the ALARM INDEX button is pressed.

INDEX disappears when the ALARM INDEX button is pressed again.

INDEX flashes during alarm indexing.

39. DIGITAL COUNTER

Shows the tape counter. The counter does not count during non-recorded sections of a tape.

40. TAPE SPEED INDICATOR

Shows the tape speed.

[REAR]

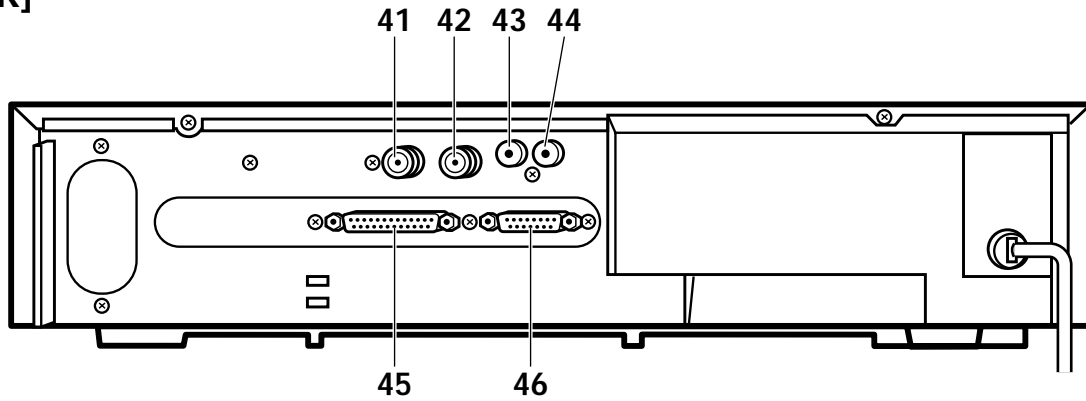

41. VIDEO IN

Receives video signal from a video camera or another VCR.

42. VIDEO OUT

For connection to monitor.

43. AUDIO IN

Accepts an audio signal from a camera, external sound equipment or another recorder (Line: -8 dBm, 50 Kohm, unbalanced).

44. AUDIO OUT

Provides an audio output for a monitor or another recorder (-9 dBm, 600 ohm, unbalanced).

45. RS-232C INTERFACE (D-SUB25) JACK

Used to operate this VCR from a personal computer on control system.

46. EXTERNAL INTERFACE (15-PIN) JACK

Connect an alarm switch, door sensor, etc. using the 15-pin adapter provided.

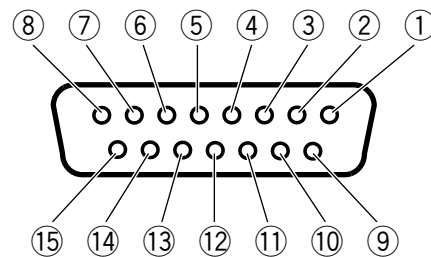

- ① ALARM (A) IN
- ② ALARM OUT
- ③ ONE SHOT IN
- ④ TAPE END OUT
- ⑤ TAPE END RESET
- ⑥ WARNING OUT
- ⑦ ALARM B IN
- ⑧ TIME ADJUST
- ⑨ CAMERA SW OUT
- ⑩ REC START IN
- ⑪ REC OUT
- ⑫ LOW TAPE OUT
- ⑬ REMOTE IN
- ⑭ REC CHECK IN
- ⑮ GND

INSTALLATION

VIDEO CONNECTIONS

Use coaxial cables when connecting a camera and a monitor to this VCR.

Note: Long cable runs to distant cameras may cause signal deterioration and/or sync discrepancies. If these problems occur, use video line amplifiers and/or cameras having phase-adjustable line-locked vertical sync.

Video Input

In single camera systems, connect the camera to the Video IN BNC terminal on the VCR rear panel. Use of a 2:1 interlace camera is highly recommended; otherwise, the monitor will show vertical distortion of the TIME/DATE characters.

In multiple camera systems, connect the switcher output to the Video IN BNC terminal. Because multiple camera systems require synchronization, use of cameras having line-locked vertical sync or a gen-locked master drive/sync source is highly recommended. The use of vertical interval switchers is also recommended.

Video Output

Connect the monitor to the Video OUT BNC terminal on the rear panel.

AUDIO CONNECTIONS

Note: Audio recording can be performed at the 06, 18 and 30-hour recording speeds and audio playback at the 06, A18, and A30 speeds.

Audio In: Accepts an audio signal from a camera, external sound equipment, or another recorder (Line: -8 dBm, 50 kohm).

Audio Out: Provides an audio output for a monitor or another recorder (-9 dBm, 600 ohm, unbalanced).

USING THE 15-PIN ADAPTER

Attach the wires of the alarm switch, door sensor or warning lamp to the 15-pin adapter using screws.

After connection, connect the adapter to the EXTERNAL INTERFACE jack on the rear of the VCR.

See pages 10 and 11 for details.

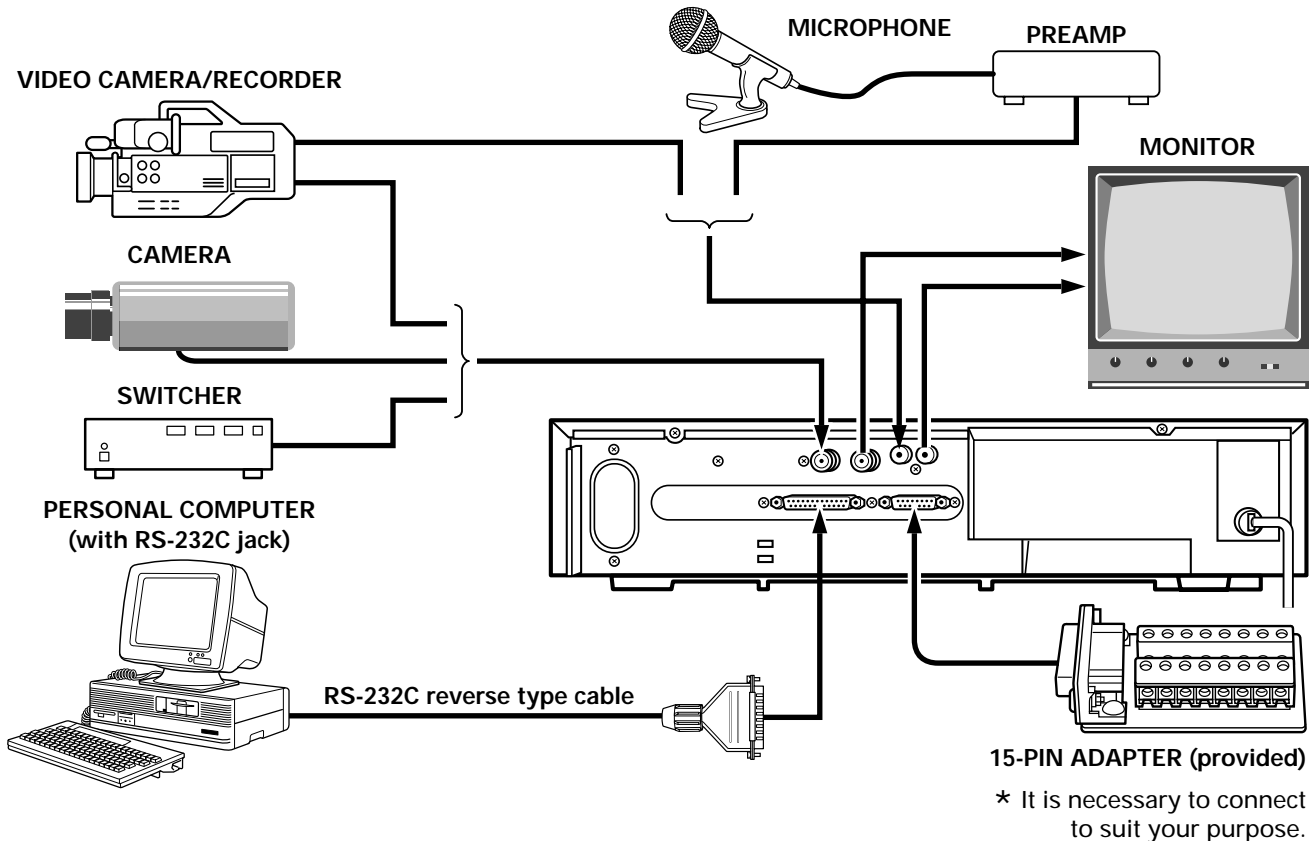

Functions of RS-232C Connector Pins

- | | |
|------------------------------------|------------------------|
| 1. Ground | 2. Data transmission |
| 3. Data reception | 4. Connected to pin 5. |
| 6. Connected to pin 20. | 7. Ground |
| 8 ~ 19 and 21 ~ 25. Not connected. | |

Note: The RS-232C is a standard null-modem cable that can be purchased locally.

EXTERNAL CONNECTIONS

Pin Arrangement of 15-Pin Adapter

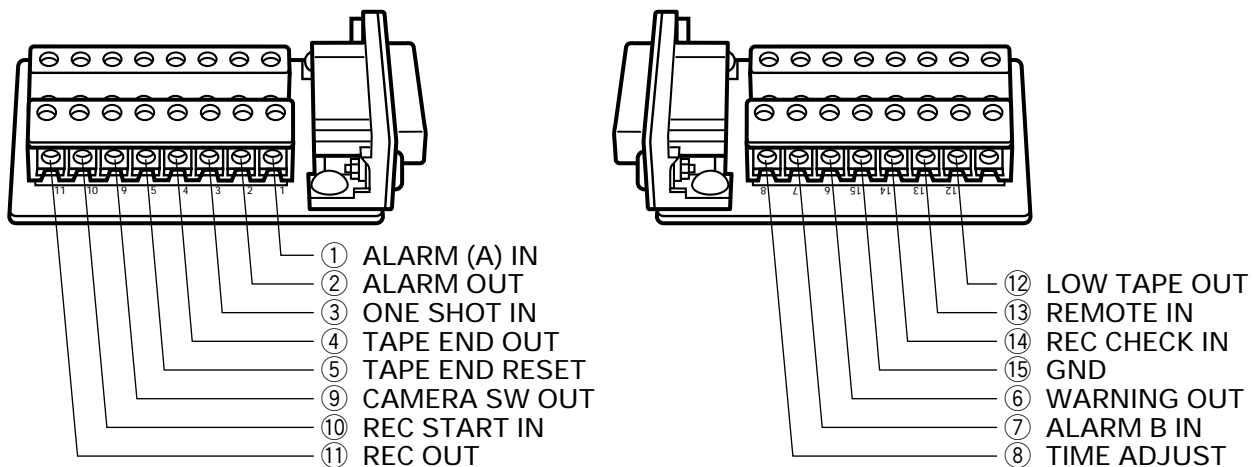

ALARM (A) IN/ ALARM B IN

You can connect two devices including an alarm switch with a resistance of 1 kohm or less or a door sensor. Connect pin ① or ⑦ to pin ⑮ (ground) through the switches.

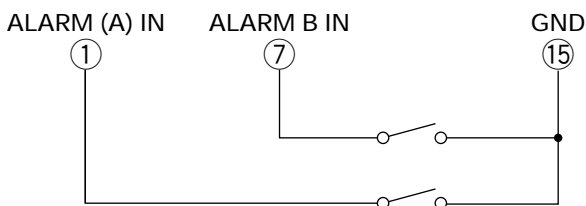

Notes:

- Do not apply a voltage to pin ①, ⑦ or ⑮.
- If an alarm is input to the ALARM (A) IN terminal when an alarm is being input to ALARM B IN, the input at ALARM (A) IN has priority. However, an alarm at ALARM B IN is not accepted when an alarm is being input to ALARM (A) IN.
- The recording conditions are different for the alarms input to the ALARM (A) IN and ALARM B IN terminals. See page 19 for details.

ALARM OUT

Approx. 12V is applied to pin ② during an alarm recording.

Notes:

- When you have selected "PULSE" in the "ALARM OUT" menu in the ALARM display, approx. 12V pulses will be applied to the output after the alarm recording ends.
- When you have selected "DURATION" in the "ALARM OUT" menu in the ALARM display, no voltage is applied after the alarm recording ends.
- The output impedance is approx. 100 ohm.

ONE SHOT IN

One shot recording is possible when pin ③ is shorted to pin ⑮.

Note: Do not apply a voltage to pin ③ or ⑮.

TAPE END OUT

Approx. 12V is applied to pin ④ when the tape reaches the end.

Notes:

- This does not operate when you have selected "REWIND, RE-REC" in the "RECYCLE FUNCTIONS" menu in the ALARM display or you have selected "REWIND, STOP IF ALARM" and no alarm recording has been made.
- The output impedance is approx. 100 ohm.

TAPE END RESET

The TAPE END OUT can be turned off when pin ⑤ is shorted to pin ⑮.

Note: Do not apply a voltage to pin ⑤ or ⑮.

EXTERNAL CONNECTIONS (Continued)

CAMERA SW OUT

Pin ⑨ outputs the following signal each time a one-field image is recorded. You can combine this with a video camera switcher which can be controlled externally.

The output timing can be specified using the SELECTION MENU screen.

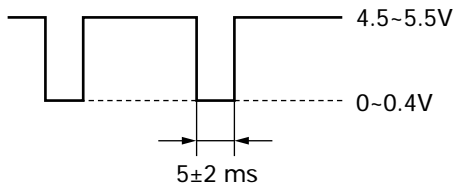

REC START IN

Recording is started when 5 ~ 12V is applied to pin ⑩.

REC OUT

Approx. 5V is applied to pin ⑪ during recording. The output impedance is 4.7 kohm at this time. The output stops when recording is interrupted.

LOW TAPE OUT

During recording, when the digital counter counts up to "21600", approx. 12V is applied to pin ⑫. Use this function as a reference to judge when the tape is near its end.

The output stops when a TAPE END RESET pulse is input or the EJECT button is pressed.

Note: The output impedance is approx. 100 ohm.

REMOTE IN

This VCR can be remote controlled when the following circuit is connected to pin ⑬.

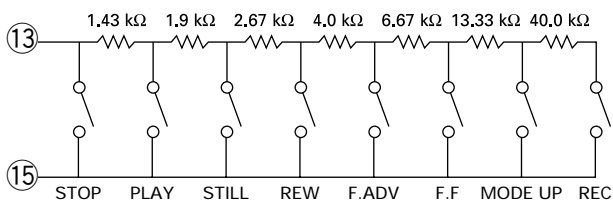

The above resistance values have a tolerance of ±2%.

REC CHECK IN

Recording can be checked when pin ⑭ is shorted to pin ⑮ during recording mode. The recorded material is played back for several seconds so that you can check whether recording is made normally or not.

WARNING OUT

When an abnormality has occurred in this VCR, approx. 5V is output to pin ⑥ to warn the user.

TIME ADJUST

When two or more of this VCR model are used, connect via pins ⑧. With only one VCR, specify TIME ADJUST: MASTER, in [OPTIONS] items on the CLOCK SET display. Specify TIME ADJUST: SLAVE (default setting at the factory) for all other VCRs. Each time "2:00:05" is reached, the VCR set to MASTER transmits pulses for adjustment to the VCRs set to SLAVE. When the VCRs set to SLAVE receive these pulses, their clocks will adjust to the same time as the clock in the VCR set to MASTER.

Note: Be sure to set only one VCR to MASTER. If no VCR is set to MASTER, or two or more VCRs are set to MASTER, the TIME ADJUST function will not operate normally.

CASSETTE TAPES

It is recommended that you use standard grade VHS video tapes of the following makers:

Maxell TDK Fuji

TAPE LIFE

Slower speed operation in time lapse recording applies stress to video tape. Tapes should be inspected and, if necessary, discarded after the total number of complete tape passes (recording and playback) exceeds the following limits:

Tape Speed	Complete Tape Passes
06, 18, 30	50
48, 72, 120, 168, 240	25

INSERTING A CASSETTE

Note: This is the first step in all VCR operations. The VCR will not operate without a cassette in place. To insert a cassette push the cassette through the cassette compartment door until the VCR mechanism pulls it into the compartment. The tape-in indicator turns on.

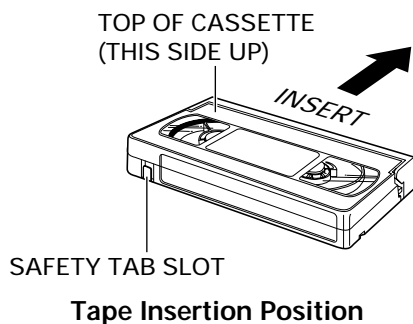

Tape Insertion Position

REMOVING A CASSETTE

Before removing a cassette, rewind the tape completely. To remove a cassette, press the EJECT button. The cassette will come partially out of the compartment so you can pull it out.

VIDEO CASSETTE SAFETY TAB

To prevent accidental erasure of recorded material, remove the safety tab from the lower left corner of the cassette.

Recording is impossible when the safety tab is removed.

Notes:

- The TAB indicator lights when a cassette without its safety tab is loaded.
- To record again on a cassette that has its safety tab removed, cover the tab hole with tape. In the TIMER mode, the TIMER indicator will flash on and off if the cassette is inserted without its safety tab slot covered or intact.

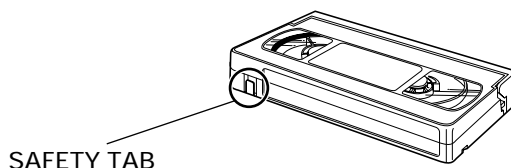

TO PREVENT ACCIDENTAL ERASURE, BREAK OFF THE TAB



TO RECORD AGAIN, COVER THE HOLE WITH TAPE

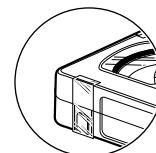

Video Cassette Safety Tab

TAPE LENGTH

The total recording time at each of the nine tape speeds depends on the length of the tape used. The table below shows:

1. The total recording time that can be recorded at each tape speed mode on T60 and T120 tapes.
2. The pictures per second at each speed.
3. The speeds at which audio can also be recorded.

Use the table to select the tape length which gives the best compromise between tape cost, total recording time, and elapsed time between pictures.

Tape Speed Mode		00	06	18	30	48	72	120	168	240
Total Recording Hours	T60	—	3	9	15	24	36	60	84	120
	T120	—	6	18	30	48	72	120	168	240
Pictures/Second	RECORD	6.67	60	20	12	6.67	4.61	2.86	2.07	1.33
	PLAYBACK	—	60	20	12	6.67	4.61	2.86	2.07	1.33
Audio	RECORD	No	Yes	Yes	Yes	No	No	No	No	No
	PLAYBACK	No	Yes	Yes (A18)	Yes (A30)	No	No	No	No	No

Note: The values in this table are approximate.

SETUP

On-Screen displays are provided to aid setup of the programmable functions. The six functions on the Program Menu appear individually on the monitor in this order.

1. CLOCK SET
2. TIMER
3. SELECTION MENU I
4. SELECTION MENU II
5. ALARM
6. ALARM MEMORY

CLOCK SET	<pre>(CLOCK SET) 1-01-1999 FRI 12:00: A (OPTIONS) OSD TYPE: OFF TIME ADJUST: SLAVE</pre>
TIMER DISPLAY	<pre>(1) 12:00A → 12:00A 06 (2) 12:00A → 12:00A 06 (3) 12:00A → 12:00A 06 (4) 12:00A → 12:00A 06 (5) 12:00A → 12:00A 06 (6) 12:00A → 12:00A 06 (7) 12:00A → 12:00A 06 MON:* * TUE:* * WED:* * THU:* * FRI:* * SAT:* * SUN:* *</pre>
SELECTION MENU I	<pre>(SELECTION MENU) SEARCH SPEED: X5 ONE SHOT REC: 6FIELD BAUD RATE: 9600BAUD CAMERA SW: ALL</pre>
SELECTION MENU II	<pre>(SELECTION MENU) BUZZER SELECTION TAPE END: OFF TROUBLE: OFF NO VIDEO: OFF AUTO REC CHECK: OFF ALARM OUT: OFF</pre>
ALARM DISPLAY	<pre>(ALARM SET) DURATION: MANUAL SPEED: 06 ALARM READY: YES ALARM OUT: DURATION (RECYCLE FUNCTIONS) REWIND, STOP IF ALARM</pre>
ALARM MEMORY DISPLAY	<pre>(ALARM MEMORY) A00 1 2 3 4 5 6 7 8 9</pre>

Initial Program Function Display Formats

Note: If the VCR is not turned on for about 720 hours after the built-in battery is fully charged (after the VCR is turned on for more than 48 hours), the TIME/DATE display will be cleared.

SELECTING A FUNCTION TO BE PROGRAMMED

The program menu will always begin with the CLOCK SET function, followed by the TIMER, SELECTION MENU I, SELECTION MENU II, ALARM, and then the ALARM MEMORY functions. Although the program menu always follows this order, it is possible to skip any of the available functions during the selection process.

To select the desired program function (and to move from one program function to the next), press the PROGRAM button repeatedly until the desired function display format appears on the monitor.

After the desired function has been selected, follow the corresponding procedure to set that function.

SETTING THE PROGRAM FUNCTION(S)

The first step in each programming procedure is: "Press the START/STOP button". The system allows up to five minutes for any one function setting to be completed after the START/STOP button is pushed. If no change/setting is entered within the five minutes period, the unit will automatically exit the selected program function. (If this happens, re-select the desired program function, and follow the programming procedure for that function.)

The following procedures for setting VCR functions assume that the desired function has already been selected.

Note: During programming, holding the SET, UP, or DOWN button will move/change the displayed information at a rapid rate.

SETTING THE TIME AND DATE

Use the CLOCK SET display to set the date and time.

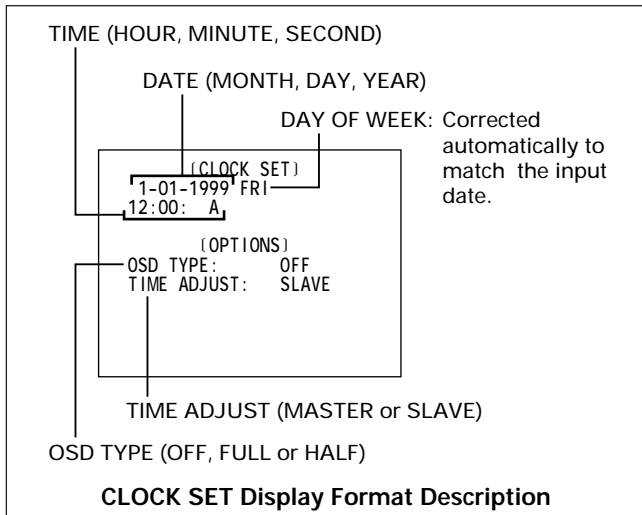

Notes:

- Perform the same procedure as when setting the time and date to make corrections after having set them. The minutes flash on/off when the SET button is pressed (in step 2 above).
- To record time and date on the tape, display them on the monitor screen. If they are not displayed on the monitor, they cannot be recorded on the tape.

1. Press the START/STOP button so that [CLOCK SET] flashes on/off.
2. Press the SET button. The day flashes on/off.
3. Press the UP or DOWN button until the desired number appears on the monitor.
4. Press the SET button. The month flashes on/off.
5. Press the UP or DOWN button until the desired number appears on the monitor.
6. Press the SET button. The year flashes on/off.
7. Press the UP or DOWN button until the desired number appears on the monitor.
8. Press the SET button. The hour flashes on/off.
9. Press the UP or DOWN button until the desired number appears on the monitor.
Remember to watch the AM/PM indicator when setting the hours.
10. Press the SET button. The minutes flash on/off.
11. Press the UP or DOWN button until the desired number appears on the monitor.
12. Press the START/STOP button: the seconds will start counting and the clock will start. [CLOCK SET] will flash on/off again at this time.
13. To display the time/date you have set here on the monitor screen, press the START/STOP button again to cause [OPTIONS] to flash, and then proceed with step 2 in item on OSD TYPE on page 15.
14. Press the START/STOP button three times.
 - Make sure that letters [CLOCK SET] or [OPTIONS] are not flashing.

SETUP (Continued)

SETTING [OPTIONS] ITEMS

OSD TYPE: The TIME/DATE display was not designed to appear at the factory. If you wish to record the time/date together with image, perform the following procedure:

There are two types of TIME/DATE display: FULL and HALF.

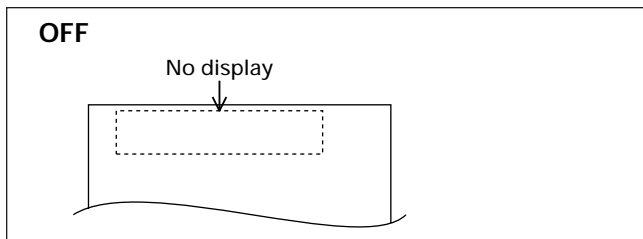
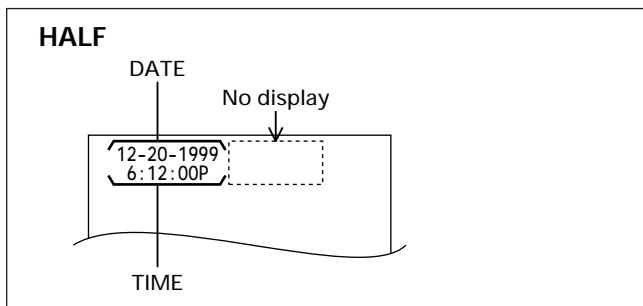
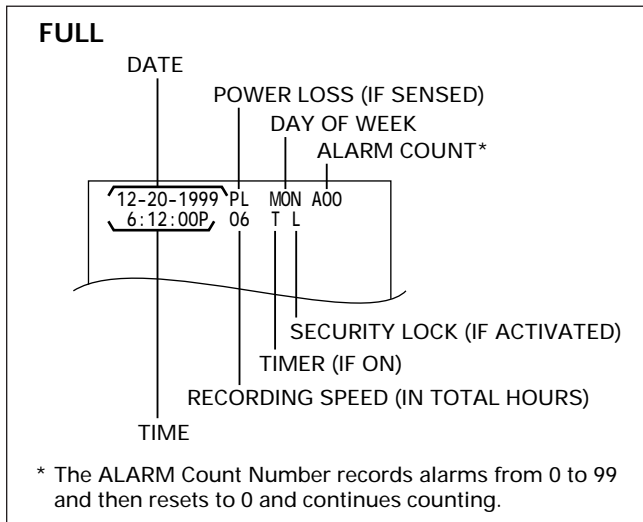

1. Press the START/STOP button twice so that [OPTIONS] flashes on/off.
2. Press the SET button so that the OSD TYPE: setting flashes on/off.
3. Press the UP or DOWN button to select the setting (OFF, FULL or HALF).
4. Press the START/STOP button again. The selected setting will light.

Note: The position of the TIME/DATE display on the monitor can be adjusted by using the H-POS and V-POS button on the front panel.

TIME ADJUST: When two or more of this VCR model are connected to pins ⑧ TIME ADJUST of each EXTERNAL INTERFACE jack, the clocks in both VCRs can automatically be set to the same time (TIME ADJUST function).

To use the TIME ADJUST function, set one VCR to MASTER and any others to SLAVE.

1. Press the START/STOP button twice so that [OPTIONS] flashes on/off.
2. Press the SET button twice so that the TIME ADJUST: setting flashes on/off.
3. Press the UP or DOWN button to select the setting (SLAVE or MASTER).
4. Press the START/STOP button again. The selected setting will light.

Notes:

- You can set OSD TYPE and TIME ADJUST after you have set the date and time.
- The TIME ADJUST function operates only when the VCRs are turned on. Therefore, turn the VCRs on around 2:00:05. This function will not operate if the times on the MASTER and SLAVE VCRs drift by more than one hour and 30 minutes.

SUMMER TIME FUNCTION

Set the summer time function when a cassette is not loaded in this VCR.

Press the SUMMER TIME and UP buttons simultaneously in modes other than the timer recording standby mode; the hour display will be counted up by one.

Press the SUMMER TIME and DOWN buttons simultaneously to count the hour display down by one.

You can change the hour display in one-hour steps without any limit by pressing the above buttons.

Note: Summer time cannot be set unless TIME/DATE is displayed.

SETTING THE TIMER

To set the 24 Hour On/Off Timer function

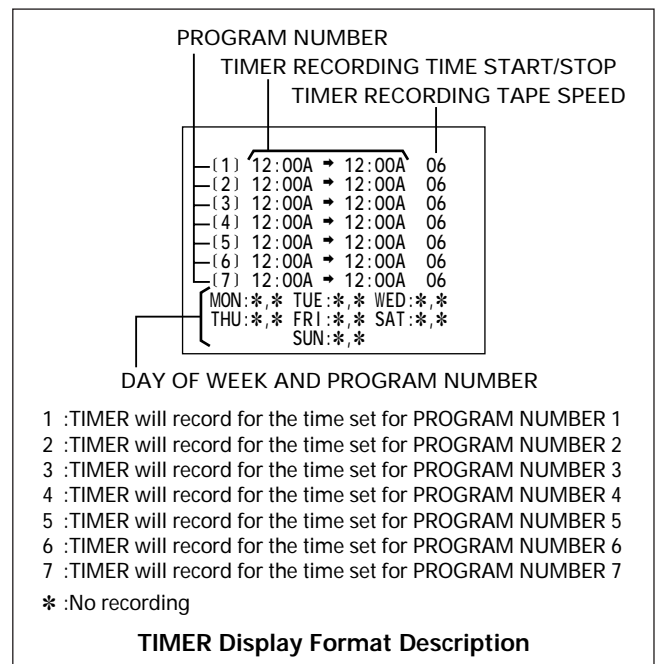

1. Press the START/STOP button.
The program number (1) flashes on/off.
2. Press the SET button. The start hours flash on/off.
3. Press the UP or DOWN button until the desired number appears on the monitor.
Remember to watch the AM/PM indicator when setting the hours.
4. Press the SET button. The start minutes flash on/off.
5. Press the UP or DOWN button until the desired number appears on the monitor.
6. Press the SET button. The stop hours flash on/off.
7. Repeat steps 3 through 5 to set the stop hours and minutes. Remember to watch the AM/PM indicator when setting the hours.
8. Press the SET button. The timer recording speed flashes on/off.
9. Press the UP or DOWN button until the desired number appears on the monitor.
10. Press the SET button after setting the timer recording speed. The program number of the next lower line flashes on/off.
11. Repeat steps 2 through 9 to set the program to the other program numbers.
12. Press the SET button after setting the program numbers (1) through (7).
The two program event locations of MON flash on/off.
13. Press the SET button. The first program event location of MON flashes.
14. Press the UP or DOWN button until the desired program number appears on the monitor.
15. Press the SET button. The other program event location of MON flashes on/off.
16. Press the UP or DOWN button until the desired program number appears on the monitor.

Notes:

- If you do not need to timer record two events a day, mark either event with an asterisk (*).
 - If two asterisks are displayed, no timer recording is made on that day.
17. After setting two program event locations of MON, press the SET button. The two program event locations of the next day of the week flashes on/off.
 18. Press the SET button. The first program event location of the next day flashes.
 19. Repeat steps 12 through 16 to set the program event locations up to SUN.
 20. Press the START/STOP button when the TIMER has been set.

Notes:

1. Programming the TIMER function does not activate it. See TIMER recording, page 21.
2. To record the time and date press the PROGRAM button to display them.
3. When the preset START time is later than the STOP time, the recording will be made into the following day.
4. When the START time and STOP time are the same, a recording will not be made.
5. When the programs for timer recording overlap each other, recording will be switched to the program with the later recording start time.

Example

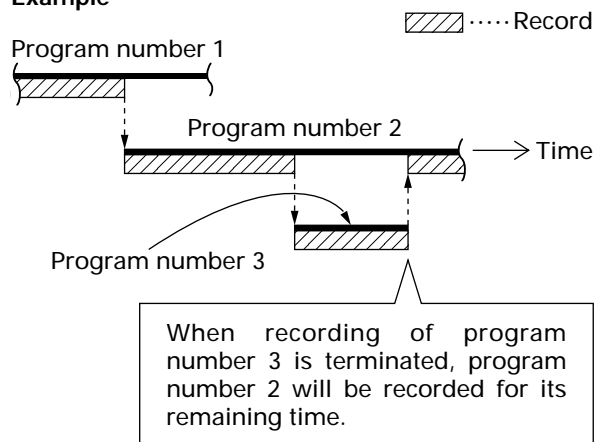

6. When two programs have the same start time, the program number with the earlier stop time has priority.

■ **To correct information**

1. Press the START/STOP button.
2. Press the UP or DOWN button repeatedly until the item to be corrected (Program number or program event location of day of the week) flashes on/off.
3. When the section to be corrected flashes on/off, press the SET button.
 - Press the SET button again so that only the digit to be corrected flashes on/off.
4. Press the UP or DOWN button to correct the set information.
5. After completing the correction, press the START/STOP button.

SETUP (Continued)

SETTING THE VCR FUNCTIONS

The SELECTION MENU I screen allows you to select the VCR operations and functions to match the applications.

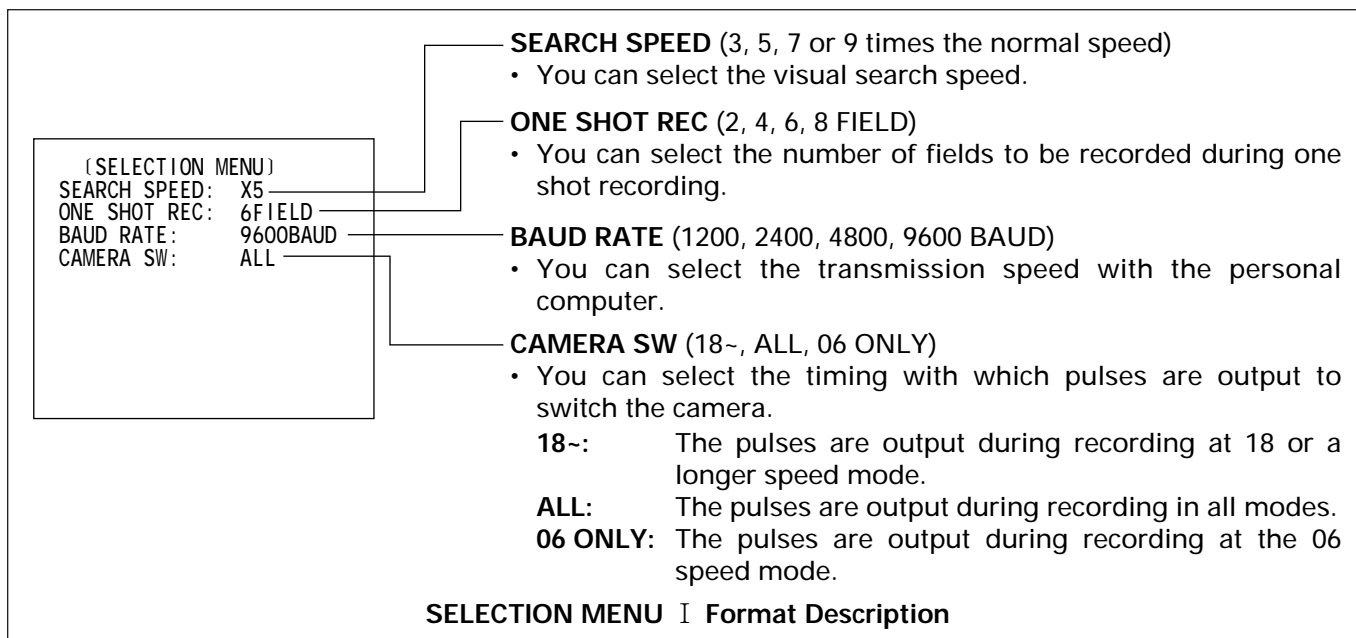

1. Press the START/STOP button.
The SEARCH SPEED option "X5" flashes on/off.
2. Press the SET button repeatedly until the item the setting of which you want to change flashes.
3. Press the UP or DOWN button to select the value or setting you want.
4. After selecting, press the START/STOP button.

SETTING THE BUZZER

This VCR has a buzzer function.

Use SELECTION MENU II to select the times when you wish buzzer to sound.

Note: "OFF" is specified for all buzzer options at the factory.

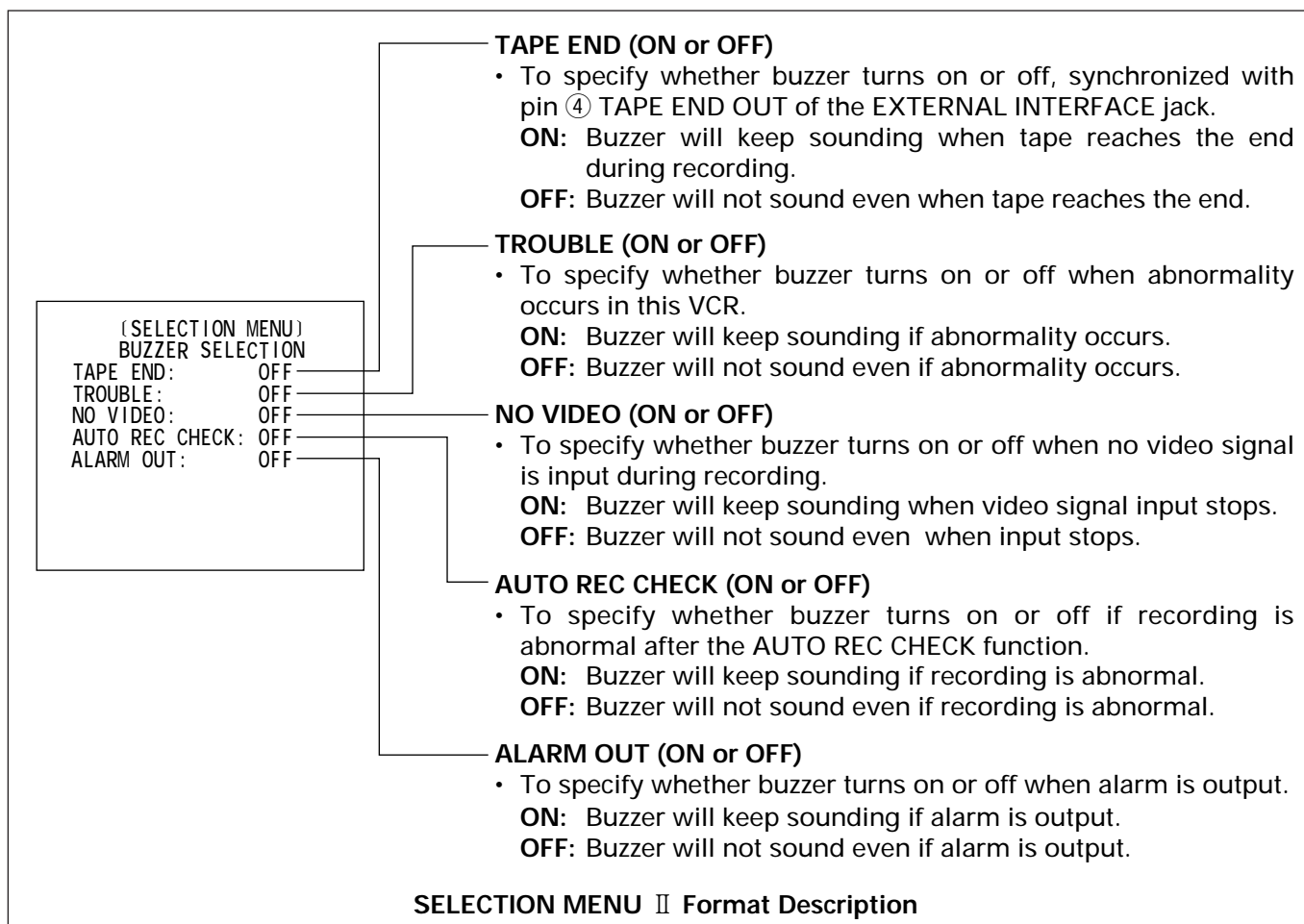

1. Press the START/STOP button.
The TAPE END option "OFF" flashes on/off.
2. Press the SET button repeatedly until the item the setting of which you want to change flashes.
3. Press the UP or DOWN button to select the value or setting you want.
4. After selecting, press the START/STOP button.

To stop buzzer:

1. When [TAPE END] lights in the VCR display, press the EJECT button: The tape will come out and the buzzer will stop.
2. When "A" lights in the VCR display and also "NO VIDEO" appears on the monitor screen, the buzzer will stop when video signal is input.
3. When "REC CHECK" appears on the monitor screen, press the STOP button: The buzzer will stop.
4. When alarm indicator [ALARM] flashes in the VCR display, press the ALARM RESET button: The buzzer will stop.
5. If buzzer function varies in any of the above cases, the VCR may be abnormal. Press the RESET buttons simultaneously: The buzzer will stop. However, note carefully that all settings will return to initial values set at the factory.

Note: You can also stop buzzer by switching ON to OFF in SELECTION MENU II.

SETUP (Continued)

SETTING THE ALARM

The ALARM function allows the user to set the recording duration, speed to be recorded and tape recycle for alarm recordings. When a contact closure occurs at the ALARM B IN input, the VCR automatically enters the RECORD mode at the pre-programmed ALARM recording speed. (See Alarm In, page 10 for a complete description of the ALARM sequence.) The ALARM recording duration can last according to the set value, or until the contact closure is reopened.

The ALARM recording speed can be pre-programmed to 06~240.

The checking signal is automatically recorded on the tape at the beginning of each ALARM recording. Later, you can easily locate the start of each recording by using these signals when watching a recorded content. See "ALARM INDEX SEARCH" on page 23 for details.

See page 15 if you also want to record the date/time. The TIME/DATE display is set as follows during ALARM display.

- ALARM stars (*) will replace the colons (:).
- The recording speed will be changed to 06~240 which was selected at the "SPEED" setting in the ALARM display.

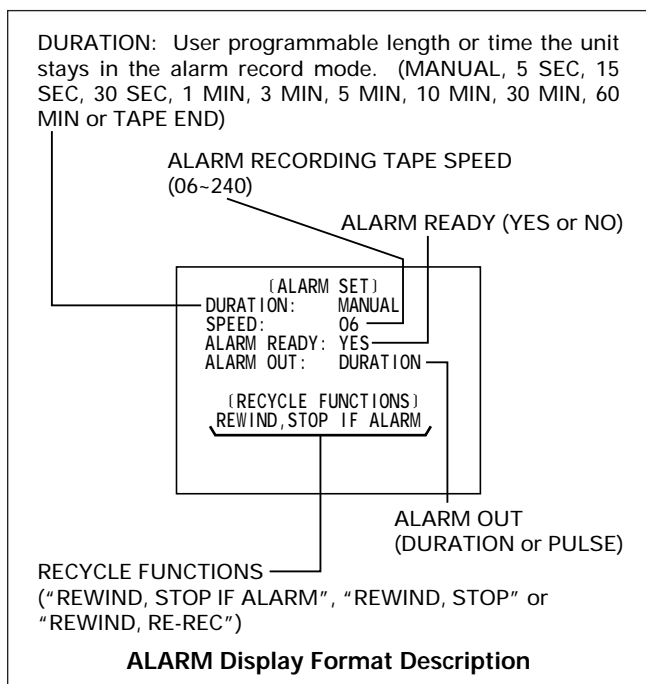

Notes:

- When the ALARM recording ends, the VCR will return to the status it was in before the alarm was input.
 - Select 06 at the "SPEED" setting when the duration is within 30 seconds. If the 18~240 speed is selected, electronic "marks" are not recorded on the tape and alarm index search will not operate.
1. Press the START/STOP button. The duration setting flashes on/off.
 2. Press the UP or DOWN button until the desired setting appears on the monitor. (MANUAL, 5, 15, 30 SEC, 1, 3, 5, 10, 30, 60MIN, TAPE END)
 3. Press the SET button. The record speed setting flashes on/off.
 4. Press the UP or DOWN button until the desired setting appears on the monitor. (06~240 HR.)
 5. Press the SET button. The alarm ready setting flashes on/off.
 6. Press the UP or DOWN button to select the alarm ready function. (YES or NO)
Select "YES" if you want to start alarm recording even in the normal record or stop mode.
Select "NO" if you do not want alarm recording in the stop mode.
 7. Press the SET button. The alarm out setting flashes on/off.
 8. Press the UP or DOWN button to select the alarm out function. See "ALARM OUT" on page 10 for details. (DURATION or PULSE)
 9. Press the SET button.
The RECYCLE position flashes on/off.
 10. Press the UP or DOWN button to select the mode at the end of tape. See "TAPE RECYCLE" on page 21 for details.
 11. Press the START/STOP button.
Programming for the ALARM has been completed.

Caution when input to ALARM (A) IN:

The conditions for recording an alarm input to ALARM (A) IN are fixed as follows.

Note: The ALARM READY function can be specified as YES or NO.

[Conditions for recording the input to ALARM (A) IN]

DURATION: MANUAL

MODE: 06

ALARM OUT: DURATION

RECYCLE FUNCTION: REWIND, STOP IF ALARM

ALARM MEMORY RECALL AND RESET

The VCR signals that an alarm has occurred by flashing the ALARM indicator. If a power loss has occurred, "PL" will appear in the first line of the FULL type TIME/DATE display.

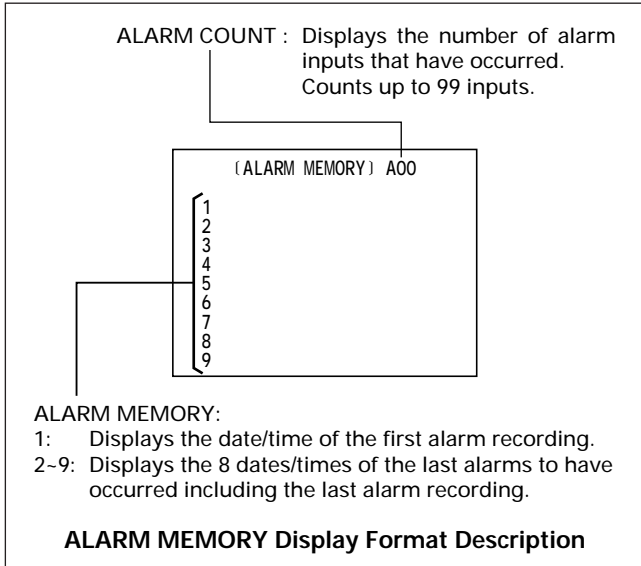

To recall the ALARM display:

1. Press the PROGRAM button until the ALARM MEMORY display appears on the monitor.
2. Log the time/date information from the ALARM memory.

To reset the ALARM memory:

- When the ALARM RESET button is pressed once, if "PL" is flashing, "PL" will disappear. Press the button again to clear the ALARM memory.
- When "PL" is not flashing, press the ALARM RESET button once to clear the ALARM memory.

OPERATION

TAPE RECORDING

CAUTION: Recording over existing recorded material will completely erase that material. To prevent accidental recording over the end of a previous recording, advance the tape several seconds before beginning the next recording.

1. Insert a video cassette; be sure the cassette safety tab is intact, or the tab slot is covered.
2. Press the REC/PLAY HOURS button until the desired tape speed is observed on the tape speed indicator.
3. Press the RECORD button to start recording.
4. Press the STOP button to stop recording.

Notes:

- The tape speed mode can be changed during recording.
- AUDIO can be recorded at 06, 18 or 30 tape speed modes.
- “NO VIDEO” will be displayed when no video signal input during recording.

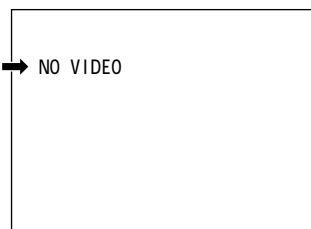

This VCR offers three special recording functions, ONE SHOT recording, TIMER recording and ALARM recording.

REC CHECK

This function allows you to check whether the pictures are being recorded normally or not during recording.

When the PLAY button is pressed during recording, the recorded picture is played back for several seconds. Then recording will continue.

AUTO REC CHECK

If tape reaches the end during recording, this function allows the VCR to automatically rewind the tape and play it back for several seconds. If AUTO REC CHECK detects from playback that the tape has been normally recorded, the VCR will rewind the tape to its start. If AUTO REC CHECK detects that the tape has not been normally recorded, “REC CHECK” will appear at the top left of the monitor screen.

Note: If “AUTO REC CHECK: ON” is specified in SELECTION MENU II, the buzzer will keep sounding when tape has not been normally recorded.

ONE SHOT RECORDING

In the ONE SHOT mode, the contact closure at the input contact ONE SHOT IN, triggers the recording for 2, 4, 6 or 8 fields, the recording of 6.67 fields per second.

If the next signal is not received in approx. 3 minutes, the VCR will automatically record 2, 4, 6 or 8 fields. This process will be repeated approx. every 3 minutes.

To record in this mode; follow the tape recording procedure, steps 1 through 3, setting the tape speed mode at 00.

You can select the number of fields to be recorded in the ONE SHOT REC mode using the SELECTION MENU screen.

TIMER RECORDING

This VCR can also record at any speed on TIMER command (turn on/off to record during any 24-hour time period). To program the TIMER function, refer to pages 15 and 16.

To operate the TIMER recording function, follow the tape recording procedure, step 1, then press the TIMER button to activate the programmed TIMER function.

Notes:

- Pressing the TIMER button is not accepted during playback.
- If a start time for timer recording is reached during normal recording, timer recording is started. After the timer recording finishes, the previous normal recording mode is restored.

TAPE RECYCLE

The “RECYCLE FUNCTIONS” in the ALARM display determine the mode after recording at the end of tape.

When the “REWIND, STOP IF ALARM” is selected:

- If no alarm has been received during the recorded period, the VCR automatically rewinds to the beginning of tape and continues recording.
- If an alarm has been received via the ALARM (A) IN terminal during the recording period, the VCR automatically rewinds to the beginning of tape and then enters the STOP mode.

When “REWIND, STOP” is selected:

- When the tape reaches the end during recording, the VCR automatically rewinds to the beginning of tape and enters the STOP mode.

When “REWIND, RE-REC” is selected:

- When the tape reaches the end during recording, the VCR automatically rewinds to the beginning of tape and continues recording.

Note: When “REWIND, STOP” or “REWIND, RE-REC” is selected, the VCR operates whether an alarm has occurred or not.

Recycle	Alarms Present on Recorded Tape	Results
REWIND, STOP IF ALARM	YES	Rewinds tape, then stops. Will not respond to alarm input.
	NO	Rewinds tape then continues to record.
REWIND, STOP	YES	Rewinds tape, then stops. Will not respond to alarm input.
	NO	Rewinds tape, then stops. Will not respond to alarm input.
REWIND, RE-REC	YES	Rewinds tape then continues to record.
	NO	Rewinds tape then continues to record.

ALARM RECORDING

This VCR can automatically record at one of 8 speeds (06~240) on ALARM command.

There are two alarm inputs to ALARM (A) IN and ALARM B IN for which the recording conditions are different.

To program the ALARM function refer to page 19. The remote/contact switch must be connected to the VCR. See page 10.

To operate the ALARM recording in the stop mode: follow the tape recording procedure, step 1, then select "YES" of the ALARM READY menu in the ALARM display.

Note: An alarm input to ALARM (A) IN has priority. When an alarm is input to ALARM (A) IN when an alarm is being input to ALARM B IN the input at ALARM (A) IN is recorded. If an alarm is input to ALARM B IN when an alarm input to ALARM (A) IN is being recorded, the alarm at ALARM (A) IN continues. If the alarm at ALARM B IN continues after recording the alarm at ALARM (A) IN has ended, the alarm at ALARM B IN will be recorded.

MASTER SYSTEM RESET

Press the two reset buttons simultaneously to provide a MASTER SYSTEM RESET. Use to reset abnormal displays and operations. The programmable features must be re-programmed.

PLAYBACK

1. Rewind the tape to the desired beginning point. (Press the REWIND button, and observe the digital counter until the desired number appears.) Press the stop button.
2. Press the REC/PLAY HOURS button until the desired tape speed is observed on the tape speed indicator.
3. Press the PLAY button to initiate forward playback.

To select reverse playback, press the PLAY button and then press the REVERSE PLAY button. Forward playback resumes when the PLAY button is pressed.

Notes:

- When the REVERSE PLAY button is pressed in the forward playback mode to set the VCR to the reverse playback mode, the first several frame images may be distorted.
- When the REVERSE PLAY button is pressed during playback at the A18, A30, 30 or 48 hour speed, reverse play is performed automatically at the 72 hour speed.

- The VCR will automatically enter the STOP mode if the reverse play is continued for approx. 1 minute.

4. Press the STOP button to stop playback.

Notes:

- The tape speed mode can be changed during playback.
- When a picture recorded in the 06 mode is played back in the A18 or A30 mode, it includes noise. It is recommended that you play back pictures recorded in the 06 mode at modes higher than 30.
- When the tape reaches the end, the unit automatically rewinds to the beginning of the tape and then goes to the STOP mode.
- If the monitor display exhibits distortion in the upper part of the picture, adjust the horizontal hold control on the monitor.
- Adjust the SLOW TRACKING control to minimize noise when playing back at slow speed (more than 30 Hr).
- The playback picture is not stable and has some noise at A18 or A30 mode. And in these modes TRACKING control is not effective.

STILL PLAYBACK

When the STILL button is pressed during playback, a still picture can be seen. To start again press STILL or PLAY button and the VCR will continue playback.

Notes:

- When still playback continues for more than 5 minutes, the AUTO-PROTECT circuit operates and the VCR will enter the STOP mode automatically.
- If the picture shakes up and down during still playback, adjust the V.LOCK control.

V.LOCK ADJUST

If the picture shakes up and down during still playback, adjust the picture by the following procedure.

1. Play back a tape, recorded in the 06 mode, in the still playback mode.
 - With some monitors, if the V.LOCK control is adjusted when playing a tape recorded in modes other than 06, shaking of the still picture may not stop.
2. Adjust the V.LOCK control so the shaking of the picture stops.

Note: Shaking of the picture may not be stopped completely depending on the monitor used.

OPERATION (Continued)

PLAYBACK IN THE FIELD ADVANCE/REVERSE MODES

When you press the FIELD ADVANCE or FIELD REVERSE button during still playback mode, one field at a time can be seen.

Operates only after STILL button has been pressed.

Notes:

- An AUTO-PROTECT circuit automatically returns the unit to the STOP mode if the STILL or PLAY button is not pressed again or if FIELD ADVANCE or FIELD REVERSE button is not pressed in any five minute period.
- When the FIELD REVERSE button is pressed in the still playback mode to set the VCR to the field reverse mode, the first several frame images may be distorted.

VISUAL SEARCH (High Speed Scan)

Note: The visual search function allows the recorded material to be reviewed at 3, 5, 7 or 9 times the 06 hour speed mode.

1. Press the PLAY button.
2. Press the SEARCH (F.FWD) button to select the VISUAL SEARCH FORWARD mode, or press the SEARCH (REWIND) button to select the VISUAL SEARCH REVERSE mode.
3. Press the PLAY button again to resume normal playback.

Notes:

- The visual search speed can be changed using the SELECTION MENU I screen.
- The playback picture will have some noise in the visual search mode.

ALARM INDEX SEARCH

The alarm index search method causes electronic "marks" to be recorded on the tape at each point when the ALARM recording begins.

Later, the VCR can find these "marks" automatically, making it easy to find the beginning of each alarm for playback.

These check points are permanent until the tape is erased. A check mark is recorded automatically each time the VCR starts ALARM recording.

1. Press the PLAY button to start playback.
2. Press the ALARM INDEX button.
3. Press the REW or F.FWD button. The recorder enters VISUAL SEARCH mode.
4. When the VCR finds a mark, it enters normal playback mode.
5. Press REW or F.FWD button again to find next "marked" recording. The recorder advances tape to the next marked position.
6. Press the ALARM INDEX button again to release alarm index search.

Notes:

1. If another alarm comes through ALARM (A) IN when the alarm at ALARM B IN is being recorded, an electronic "mark" is written on the tape. However, an alarm at ALARM B IN is not accepted when an alarm is being input to ALARM (A) IN, so an electronic "mark" is not written on the tape with this ALARM B input.
2. Be careful as no alarm input can be detected for 5 seconds immediately after the visual search mode is entered by pressing the REW or F.FWD button during the alarm index search mode.
3. When tapes recorded by other VCRs are played in the alarm index search mode, the VCR may enter the play mode in a meaningless position.
4. When you have selected "MANUAL" at the DURATION setting in the ALARM display, and the duration of an alarm recording is shorter than the values shown below, "marks" may not be detected.

SPEED

06.....	5 seconds
18~120.....	60 seconds
168, 240.....	3 minute

TO SECURE THE VCR

This feature restricts unauthorized use, tampering, or accidental changes in the operation of the VCR. The security feature does not operate during programming. Simultaneously press the SET and DOWN buttons in the program set area of the front panel. The security message "L" appears in the TIME/DATE display (FULL) and the LOCK indicator lights in the VCR's display.

To release the security feature, press the SET and DOWN buttons simultaneously.

Note: "L" does not appear in the TIME/DATE display (HALF).

OPERATING THE VCR FROM A PERSONAL COMPUTER

Connect this VCR to a personal computer via the RS-232C interface jacks to remote control the VCR by operating the computer. You can also display the status of the VCR on the monitor screen to check it.

■ RS-232C Interface Specifications

Communication system: Full duplex
 Communication rate: 1200/2400/4800/9600 BAUD (The rate can be specified using the SELECTION MENU screen. This is set to 9600 BAUD at the factory.)
 Communication format: Start: 1 bit
 Data: 8 bits
 Parity: None
 Stop: 1 bit
 Communication codes: Two types, the ASCII and display character codes

ASCII code

The codes with diagonal line are not used.

	0	1	2	3	4	5	6	7	8	9	A	B	C	D	E	F
0	/	/	S _X	E _X	/	/	/	/	/	/	/	/	/	/	/	/
1	/	/	/	/	/	/	/	/	/	/	/	/	/	/	/	/
2	(blank)	!	/	/	/	/	/	/	/	/	*	/	,	-	/	/
3	0	1	2	3	4	5	6	7	8	9	:	/	<	/	>	?
4	/	A	B	C	D	E	F	G	H	I	J	K	L	M	N	O
5	P	Q	R	S	T	U	V	W	X	Y	Z	/	/	/	/	/
6	/	/	/	/	/	/	/	/	/	/	/	/	/	/	/	/
7	/	/	/	/	/	/	/	/	/	/	/	/	/	/	/	/

Display character code

The codes with diagonal line are not used.

	0	1	2	3	4	5	6	7	8	9	A	B	C	D	E	F
0	/	/	/	/	/	/	/	/	/	/	/	/	/	/	/	/
1	/	/	/	/	/	/	/	/	/	/	/	/	/	/	/	/
2	(blank)	/	"	/	\$	%	&	'	()	*	+	,	-	.	/
3	0	1	2	3	4	5	6	7	8	9	:	;	/	=	/	?
4	/	A	B	C	D	E	F	G	H	I	J	K	L	M	N	O
5	P	Q	R	S	T	U	V	W	X	Y	Z	/	/	/	/	/
6	/	a	b	c	d	e	f	g	h	i	j	k	l	m	n	o
7	p	q	r	s	t	u	v	w	x	y	z	/	/	/	/	/

■ Communication Protocol

1. Be sure to attach an "SX" code at the start of communications and an "EX" code at the end. The VCR does not accept the command without these codes.
2. The VCR only transmits a reply to the received command.
3. When the VCR receives one of the remote control commands shown on page 25, it returns the status for reception acknowledgment or the status requested currently.
4. If the commands are transmitted consecutively or another command is transmitted before the VCR has ended an operation, the VCR returns the "SX"BUSY"EX" code. Re-transmit the command.
5. If there is a mistake in the received communications format, the VCR returns one of the following communication error codes.
 - ERL: Error in code length
 - ERC: Error in code format
 - ERT: Error inside the VCR (when return is not possible within about 2 seconds)
6. When the VCR detects a communications error such as a stop bit error, bit length error, etc., it replaces the received byte with "!" for processing.
 - * If a communications error occurs in the OSD display data, the OSD character is replaced with "!". If a communications error occurs in data other than the above, a communications error code is returned.

■ OSD Display Data

When the date and hour are displayed or nothing is displayed (only the picture is displayed), up to 12 characters are displayed at the position shown in the figure.

Up to 12 characters are displayed at this position.

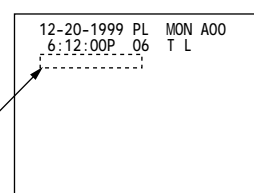

OPERATING THE VCR FROM A PERSONAL COMPUTER (Continued)

■ Format of Commands and Status

See pages 26 and 27 for the meanings of the small letters in the table.

	Function of command	Format of command	Status for reception acknowledgment
Remote operation	Stop	$S_xSTO^E_x$	$S_xSTO^E_x$ i
	Fast forward	$S_xFWD^E_x$	$S_xFWD^E_x$ u
	Rewind	$S_xREW^E_x$	$S_xREW^E_x$ y Operates the VCR in the same
	Recording	$S_xREC^E_x$	$S_xREC^E_x$ u way as when its buttons
	Playback	$S_xFPL^E_x$	$S_xFPL^E_x$ u are pressed.
	Reverse play	$S_xRPL^E_x$	$S_xRPL^E_x$ u
	Frame advance	$S_xFAD^E_x$	$S_xFAD^E_x$ u
	Reverse frame advance	$S_xRAD^E_x$	$S_xRAD^E_x$ u
	Pause/still play	$S_xPAU^E_x$	$S_xPAU^E_x$ u
	Pause/still play ON	$S_xPA1^E_x$	$S_xPA1^E_x$ u
	Pause/still play OFF	$S_xPA0^E_x$	$S_xPA0^E_x$ u
	Tape eject	$S_xEJE^E_x$	$S_xEJE^E_x$ t
	One shot input	$S_xOSR^E_x$	$S_xOSR^E_x$ Controls pin ③.
	Alarm index ON/OFF	$S_xAlw^E_x$	$S_xAlw^E_x$ i
	Timer ON/OFF	$S_xTSS^E_x$	$S_xTSS^E_x$ y Operates the VCR in the same
	Mode lock ON/OFF	$S_xMLI^E_x$	$S_xMLI^E_x$ u way as when its buttons
	Alarm reset	$S_xAL^-E_x$	$S_xAL^-E_x$ u are pressed.
	Counter reset	$S_xCO^-E_x$	$S_xCO^-E_x$ t
	Tape end reset	$S_xTE^-E_x$	$S_xTE^-E_x$ Controls pin ⑤.
	System control microprocessor reset	$S_xSY^-E_x$	
	Tape speed	S_xSPD r E_x	$S_xSPD^E_x$ Specifies the recording/playback mode.
	OSD screen number	S_xSCR n E_x	$S_xSCR^E_x$
	OSD horizontal display position up	$S_xHO>^E_x$	$S_xHO>^E_x$
	OSD horizontal display position	S_xHOR jj E_x	$S_xHOR^E_x$
	OSD vertical display position up	$S_xVE>^E_x$	$S_xVE>^E_x$
	OSD vertical display position	S_xVER vv E_x	$S_xVER^E_x$
	ONE SHOT REC	$S_xORF^E_x$	$S_xORF^E_x$ i
	SEARCH SPEED	$S_xSXX^E_x$	$S_xSXX^E_x$ y Settings on the SELECTION
	CAMERA SW	S_xCSW z E_x	$S_xCSW^E_x$ t MENU screen.
	Clock setting	S_xCLK yy-mm-dd, hh:ff, www E_x	$S_xCLK^E_x$ Specifies the current time.
	Alarm recording setting	S_xALA ddd, r, u, o, qq E_x	$S_xALA^E_x$ Sets the alarm recording conditions.
	Program setting	S_xPRp hh:ff, hh:ff, r E_x	$S_xPRp^E_x$ Sets a timer program.
	Timer setting	S_xwww p, p E_x	$S_xwww^E_x$ Selects the timer program on each day of the week.
OSD display	S_xOSD aaaaaaaaaaaaa E_x	$S_xOSD^E_x$ Command to display characters.	

	Function of command	Format of command	Status for reception acknowledgment
Status check	VCR running status	$s_xVCR ?^E_x$	s_xVCR bbb, s, w, l, v, a E_x i
	Tape speed	$s_xSPD ?^E_x$	s_xSPD Nr E_x u
	Cassette status	$s_xCAS ?^E_x$	s_xCAS N, b, ttt E_x u
	Time	$s_xCLK ?^E_x$	s_xCLK yy-mm-dd, hh:ff:ss, www E_x u
	Alarm count	$s_xALC ?^E_x$	s_xALC aa E_x u
	Alarm setting information	$s_xALA ?^E_x$	s_xALA ddd, r, u, o, qqqq E_x u
	Alarm memory information	$s_xALq ?^E_x$	s_xALq yy-mm-dd, hh:ff:ss E_x u
	Program setting information	$s_xPRp ?^E_x$	s_xPRp hh:ff, hh:ff, r E_x y Status
	Timer setting information	$s_xwww ?^E_x$	s_xwww p, p E_x u formats
	Counter value	$s_xCTR ?^E_x$	s_xCTR ccccc E_x u
	OSD display picture	$s_xSCR ?^E_x$	s_xSCR n E_x u
	OSD setting values	$s_xOSD ?^E_x$	s_xOSD jj, vv, B E_x u
	Various setting values	$s_xSET ?^E_x$	s_xSET x, f, C, A, A, A, 0, z E_x u
	Buzzer setting values	$s_xBZR ?^E_x$	s_xBZR β , γ , δ , ϵ , ζ E_x u
	Time adjust	$s_xTAD ?^E_x$	s_xTAD η E_x u
	Total time of use	$s_xTOT ?^E_x$	s_xTOT xxxxx, zzzzz E_x u
	Tape end signal	$s_xEND ?^E_x$	s_xEND e, g E_x t

■ Details of Small Letters

Symbol	Identification	Type of code	Details of code
a	Alarm yes/no	ASCII	1: Alarm input, 0: No alarm
aa	Number of alarms	ASCII	2-digit number (00-99 or E0-E9)
b	Safety tab on cassette	ASCII	1: Tab, 0: No tab
bbb	Running status	ASCII	Three letters STO: Stop FPL: Playback REC: Recording STI: Still RAD: Reverse frame advance REW: Rewind FWD: Fast forward REV: Reverse search CUE: Forward search RPL: Reverse play FAD: Frame advance AIS: Alarm index search
cccc	Counter value	ASCII	5-digit number (00000-99999)
dd	Day	ASCII	2-digit number (01-31)
ddd	ALARM DURATION	ASCII	Three letters or two numerals and one letter MAN: Manual, 05S: 5 s, 15S: 15 s, 30S: 30 s, 01M: 1 min, 03M: 3 min, 05M: 5 min, 10M: 10min, 30M: 30 min, 60M: 60 min, END: TAPE END
e	Tape end output (2)	ASCII	1: high, 0: low
f	ONE SHOT REC	ASCII	2, 4, 6, 8: Number of fields (in recording)
ff	Minute	ASCII	2-digit number (00-59)
g	Tape end output	ASCII	1: high, 0: low
hh	Hour	ASCII	2-digit number (00-23)
jj	Horizontal display start position	ASCII	2-digit number (03-21)
l	Mode lock	ASCII	1: ON, 0: OFF

OPERATING THE VCR FROM A PERSONAL COMPUTER (Continued)

Symbol	Identification	Type of code	Details of code
mm	Month	ASCII	2-digit number (01~12)
n	OSD screen	ASCII	one numeral (0~7) 0: Various data display (FULL) 1: Various data display (HALF) 2: Timer programming 3: Mode selection 4: Alarm record setting or recycle functions 5: Alarm memory 6: Display off 7: Head usage time
o	ALARM OUT	ASCII	D: Duration, P: Pulse
p	Timer program number	ASCII	One-digit number (1~7) or *
q	Alarm memory number	ASCII	One-digit number (1~9)
qqqq	RECYCLE FUNC.	ASCII	4 letters ALRM: REWIND, STOP IF ALARM RWND: REWIND, STOP RREC: REWIND, RE-REC
r	Tape speed	ASCII	One numeral or one letter (0~9, A, B, C, E) 0: 06, 1: A18, 2: A30, 3: 30, 4: 48, 5: 72, 6: 120, 7: 168, 8: 240, E: 00
s	Timer standby	ASCII	1: ON, 0: OFF
ss	Second	ASCII	2-digit number (00~59)
ttt	Tape status	ASCII	Three letters NTP: No cassette, END: End of tape, BGN: Start of tape, NRM: Normal status
u	ALARM READY	ASCII	Y: Yes, N: No
v	Power failure yes/no	ASCII	1: Power failure, 0: No power failure
vv	Vertical display start position	ASCII	2-digit number (02~22)
w	Alarm index	ASCII	1: ON, 0: OFF
www	Day of the week	ASCII	Three letters SUN: Sunday, MON: Monday, TUE: Tuesday, WED: Wednesday, THU: Thursday, FRI: Friday, SAT: Saturday
x	SEARCH SPEED	ASCII	3, 5, 7, 9: Search speed ratio
xxxxx	Head usage time	ASCII	5-digit number (00000~99999)
yy	Year	ASCII	2-digit number (00~99)
z	CAMERA SW	ASCII	2: 06, 0: 18~, 1: ALL
zzzzz	Total time of use	ASCII	5-digit number (00000~99999)
α	OSD characters	Display characters	See the display character code table on page 24.
β	TAPE END buzzer	ASCII	1=ON 0=OFF
γ	TROUBLE buzzer	ASCII	1=ON 0=OFF
δ	NO VIDEO buzzer	ASCII	1=ON 0=OFF
ϵ	REC CHECK buzzer	ASCII	1=ON 0=OFF
ζ	ALARM OUT buzzer	ASCII	1=ON 0=OFF
η	TIME ADJUST	ASCII	1=MASTER 0=SLAVE

PROBLEM GUIDE

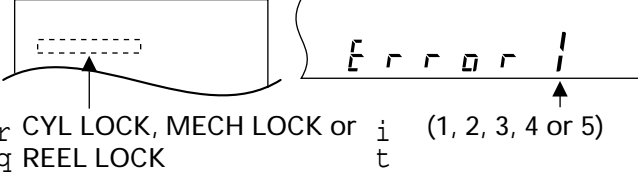
If you are having this kind of trouble:	Check these things:
<ul style="list-style-type: none"> ▪ No power (No indicators ON) 	<ul style="list-style-type: none"> □ Check to see if unit is plugged in. (Power at supply outlet?)
<ul style="list-style-type: none"> ▪ Recorder fails to respond to user command/operation 	<ul style="list-style-type: none"> □ Perform MASTER SYSTEM RESET. See page 22.
<ul style="list-style-type: none"> ▪ No monitor picture 	<ul style="list-style-type: none"> □ Carefully check monitor/VCR/camera connectors.
<ul style="list-style-type: none"> ▪ Poor picture during monitor viewing (in the RECORD or STOP mode) 	<ul style="list-style-type: none"> □ Check monitor/camera adjustments.
<ul style="list-style-type: none"> ▪ Black streaks on picture during 06, A18 or A30 mode playback 	<ul style="list-style-type: none"> □ Adjust the TRACKING control (may need to be returned to center position if previously adjusted). The TRACKING control is only active for the 06, A18 or A30 mode. □ Replace cassette. □ Clean video heads.
<ul style="list-style-type: none"> ▪ Recording or playback cannot be done 	<ul style="list-style-type: none"> □ Remove cassette and reinsert. □ Check the LOCK indicator on the front panel. If the indicator is lit, press both SET and DOWN buttons simultaneously to release the security lock.
<ul style="list-style-type: none"> ▪ RECORD functions not operate 	<ul style="list-style-type: none"> □ Check the TAB indicator is lit. □ See Note on page 12.
<ul style="list-style-type: none"> ▪ PLAY function not operate 	<ul style="list-style-type: none"> □ Be sure there is a cassette in the unit.
<ul style="list-style-type: none"> ▪ Extreme noise appears on the playback picture 	<ul style="list-style-type: none"> □ Video heads require cleaning.
<ul style="list-style-type: none"> ▪ TIME/DATE information not displayed on the MONITOR 	<ul style="list-style-type: none"> □ Select FULL or HALF with OSD TYPE in [OPTIONS]. See page 15.
<ul style="list-style-type: none"> ▪ TIMER recording was not done 	<ul style="list-style-type: none"> □ TIMER may not have been set properly. □ Check for SAFETY TAB of cassette. □ TIME and DATE are not correct. □ Cassette tape length may have been exceeded. Multiple ALARMS used up tape.
<ul style="list-style-type: none"> ▪ REWIND or FAST FORWARD does not operate 	<ul style="list-style-type: none"> □ Tape may already be rewound or be at the end of tape.
<ul style="list-style-type: none"> ▪ Unable to SELECT/CHANGE program feature 	<ul style="list-style-type: none"> □ Check the LOCK indicator on the front panel. If the indicator is lit, press both SET and DOWN buttons simultaneously to release the security lock.
<ul style="list-style-type: none"> ▪ The VCR does not operate if an operation button is pressed 	<ul style="list-style-type: none"> □ Press the EJECT button to remove the cassette, then restart VCR operations.
<ul style="list-style-type: none"> ▪ Buzzer sounds 	<ul style="list-style-type: none"> □ You have specified the buzzer to sound when abnormality has occurred. See page 18.
<ul style="list-style-type: none"> ▪ An error appears in the display  <p> r CYL LOCK, MECH LOCK or i (1, 2, 3, 4 or 5) q REEL LOCK t </p>	<ul style="list-style-type: none"> □ Unplug the power cord and plug it in again. □ Press the reset button marked "S". <p>Note: If the VCR does not recover by MASTER SYSTEM RESET, consult your dealer.</p>

SPECIFICATIONS

Video Cassette:	VHS type
Recording:	Rotary two-head helical scan azimuth recording
Tape Speed:	11.1 mm/sec. (06 mode)
Tape Width:	12.7 mm
Operation Temperature:	5°C to 40°C
Video:	NTSC color and EIA standard
Recording Lengths:	06, 18, 30, 48, 72, 120, 168, 240 hours and ONE SHOT (00 mode)
Video Input:	1 Vp-p 75 ohm unbalanced
Video Output:	1 Vp-p 75 ohm unbalanced
S/N Ratio (Video):	More than 42 dB (06 mode)
S/N Ratio (Audio):	More than 40 dB (06 mode)
Horizontal Resolution:	Color: 300 lines (06 mode) Monochrome: 350 lines (06 mode)
Audio Input:	-8 dBm 50 Kohm unbalanced
Audio Output:	-9 dBm 600 ohm unbalanced
Audio Frequency Range:	100 Hz to 5 kHz (06 mode)
Power:	AC 120V, 60 Hz, grounding type 3 prong AC plug
Power Consumption:	22W
Cabinet Size:	435 mm (W) × 94 mm (H) × 366 mm (D) 17-1/8" (W) × 3-11/16" (H) × 14-7/16" (D)
Weight:	Approx. 6.2 kg (13.7 lbs)

* Design and specifications are subject to change without notice.

Maintenance

Two periodic maintenance steps are recommended to insure the peak performance of this product.

1. Periodically make a careful observation of the quality of the playback video. If there are excessive dropouts (noise specks) across the video picture, and the TRACKING control does not clear the picture, then head cleaning may be necessary. Obtain a high quality head cleaning kit, and follow the directions carefully. The length of time between cleaning depends on the amount of airborne contaminants around the tape recorder and/or cassette.
2. The unit should be inspected every 3500 hours of continuous usage by the dealer from whom the recorder was purchased.



Free Manuals Download Website

<http://myh66.com>

<http://usermanuals.us>

<http://www.somanuals.com>

<http://www.4manuals.cc>

<http://www.manual-lib.com>

<http://www.404manual.com>

<http://www.luxmanual.com>

<http://aubethermostatmanual.com>

Golf course search by state

<http://golfingnear.com>

Email search by domain

<http://emailbydomain.com>

Auto manuals search

<http://auto.somanuals.com>

TV manuals search

<http://tv.somanuals.com>