

---

# B OAT R E MOTE

TM



## *User's Manual*

***Phonetics, Inc.***

Marine Division

901 Tryens Road Aston, PA 19014

Every effort has been made to ensure that the information in this document is complete, accurate and up-to-date. Phonetics, Inc. assumes no responsibility for the results of errors beyond its control. Phonetics, Inc. also cannot guarantee that changes in equipment made by other manufacturers, and referred to in this manual, will not affect the applicability of the information in this manual.

© 1996 by Phonetics, Inc.

First Edition, version 1.02, September 2000

Written and produced by Phonetics, Inc.

Please address comments on this publication to :

Phonetics, Inc.  
901 Tryens Road  
Aston, PA 19014

Boat Remote™ is a trademark of Phonetics, Inc.

Touch Tone™ is a trademark of AT&T.

# Table of Contents

Safety Instructions .....	v
FCC Requirements .....	vi
<b>CHAPTER 1: GETTING TO KNOW YOUR BOAT REMOTE .....</b>	<b>9</b>
Technical Support .....	11
Using the Keypad, LCD and LED Indicators .....	11
LCD (Liquid Crystal Display) .....	12
LED's .....	12
System Operating Mode .....	12
Warning LED .....	13
<b>Parts check list .....</b>	<b>13</b>
Boat Remote Package .....	13
Installation Kit .....	13
<b>CHAPTER 2: INSTALLATION .....</b>	<b>15</b>
Operating Environment .....	15
Mounting .....	15
Connecting the Power Supply .....	16
Connecting the Battery .....	17
Connecting the Telephone Line .....	17
Power Surge Protection .....	17
Connecting Accessories .....	17
High Water Float Switch .....	17
Temperature Sensors .....	19
Bilge Pump .....	20
Security Input .....	21
Auxiliary Input .....	21
Output .....	22
<b>CHAPTER 3: PROGRAMMING .....</b>	<b>23</b>
Using the Keypad, LCD and LED Indicators .....	23

<b>PROGRAMMING VOICE MESSAGES .....</b>	<b>25</b>
Recording a Voice Message .....	25
Unit ID Message .....	25
To record ID message .....	25
Temperature #1, #2, or #3 Input message .....	26
Auxiliary Input message .....	26
<b>PROGRAMMING SYSTEM PARAMETERS .....</b>	<b>26</b>
Maximum Number of Calls .....	27
Call Delay .....	28
Intercall Delay .....	28
Dialing Method .....	29
TAD (Telephone Answering Device) .....	30
Voice Repetitions .....	31
Rings until answer .....	32
Listen In .....	32
Speaker .....	33
Temperature .....	33
Output Trigger & Output Mode .....	34
Current Time & Today's Date .....	35
<b>DIAL OUT PHONE NUMBERS .....</b>	<b>35</b>
Programming the Dial Out Phone Numbers .....	36
Special Dialing .....	38
Special Dialing Keys .....	38
Dialing to a Beeper or Pager .....	39
<b>INPUTS .....</b>	<b>40</b>
AC Power Input .....	41
Battery Input .....	42
Temperature Inputs (1, 2, & 3) .....	45
Bilge Pump Inputs (2) .....	48
Emergency High Water Level Input .....	51
Auxiliary Input .....	52
Security Input .....	54
<b>VERIFYING PROGRAMMING .....</b>	<b>56</b>
The WHAT IS? key .....	56
<b>CHAPTER 4: OPERATION .....</b>	<b>59</b>
<b>PART ONE: THE ALARM SEQUENCE .....</b>	<b>59</b>
Alarm Recognition .....	59

Alarm Notification .....	59
Dial Out .....	60
Alarm Acknowledgment .....	61
<b>PART TWO: SAMPLE PROGRAMMING STRATEGY .....</b>	<b>63</b>
Communications Programming .....	63
Monitoring Programming .....	64
Examples .....	65
STATUS REPORT .....	69
<b>CHAPTER 5: TROUBLESHOOTING .....</b>	<b>71</b>
<b>COMMUNICATIONS DIAL OUT .....</b>	<b>71</b>
<b>TEMPERATURE MONITORING .....</b>	<b>73</b>
<b>OTHER MONITORING.....</b>	<b>74</b>
<b>APPENDIX A: COMMAND SUMMARY .....</b>	<b>77</b>
MODE Key .....	78
ENTER Key .....	78
DOWN ARROW Key .....	78
ARROW UP Key.....	78
CODE Key.....	78
<b>APPENDIX B: PROPER OPERATION OF YOUR BOAT REMOTE .....</b>	<b>79</b>
<b>APPENDIX C: ENGINEERING SPECIFICATIONS .....</b>	<b>81</b>
<b>APPENDIX D: RETURNING YOUR UNIT FOR REPAIR .....</b>	<b>87</b>



# Safety Instructions

Your Boat Remote has been carefully designed to give you years of safe, reliable performance. As with all electrical equipment, however, there are a few basic precautions you should take to avoid hurting yourself or damaging the unit:

Read the installation and operating instructions in this manual carefully. Be sure to save it for future reference.

Read and follow all warning and instruction labels on the product itself.

To protect the Boat Remote from overheating, make sure all openings on the unit are not blocked. Do not place on or near a heat source, such as a radiator or heat register.

Do not allow your Boat Remote to get wet, or spill liquid of any kind into it.

Be certain that your power source matches the rating listed on the AC power transformer. If you're not sure of the type of power supply to your boat, consult your dealer or local power company.

Do not allow anything to rest on the power cord. Do not locate this product where the cord will be abused by persons walking on it.

Do not overload wall outlets and extension cords, as this can result in the risk of fire or electric shock.

Never push objects of any kind into this product through ventilation holes as they may touch dangerous voltage points or short out parts that could result in a risk of fire or electric shock.

To reduce the risk of electric shock, do not disassemble this product, but return it to Phonetics' Customer Service, or another approved repair facility, when any service or repair work is required. Opening or removing covers may expose you to dangerous voltages or other risks. Incorrect reassembly can cause electric shock when the unit is subsequently used.

If anything happens that indicates that your Boat Remote is not working properly or has been damaged, unplug it immediately and follow the procedures in the manual for having it serviced. Return the unit for servicing under the following conditions:

1. The power cord or plug is frayed or damaged.
2. Liquid has been spilled into the product or it has been

exposed to water.

3. The unit has been dropped, or the enclosure is damaged.
4. The unit doesn't function normally when you're following the operating instructions.

Avoid using a telephone (other than a cordless type) during an electrical storm. There may be a remote risk of electric shock from lightning. Do not use the telephone to report a gas leak in the vicinity of the leak.

## FCC Requirements

Part 68: The Boat Remote complies with Part 68 of the FCC rules. On the back of the unit there is a label that contains, among other information, the FCC Registration Number and the Ringer Equivalence Number (REN) for this equipment. You must, upon request, provide this information to your local telephone company. The REN is useful to determine the quantity of devices that you may connect to your telephone line and still have all of those devices ring when your telephone number is called. In most, but not all areas, the sum of the REN's of all devices connected to one line should not exceed five (5.0). To be certain of the number of devices that you may connect to your line, you may want to contact your local telephone company to determine the maximum REN for your calling area.

This equipment may not be used on coin service provided by the telephone company. Connection to party lines is subject to state tariffs.

Should the Boat Remote cause harm to the telephone network, the telephone company may discontinue your service temporarily. If possible, they will notify you in advance. But if advance notice isn't practical, the telephone company may temporarily discontinue service without notice and you will be notified as soon as possible. You will be informed of your right to file a complaint with the FCC. The telephone company may make changes in its facilities, equipment, operations, or procedures where such action is reasonably required in the operation of its business and is not inconsistent with the rules and regulations of the FCC that could affect the proper functioning of your equipment. If they do, you will be notified in advance to give you an opportunity to maintain uninterrupted telephone service.

If you experience trouble with this equipment, or you need information on obtaining service or repairs, please contact:



***Phonetics, Inc.***

901 Tryens Road, Aston, PA 19014  
(610) 558-2700 Fax: (610) 558-0222  
www.sensaphone.com

The telephone company may ask that you disconnect this equipment from the network until the problem has been corrected or until you are sure that the equipment is not malfunctioning.

Part 15: This equipment has been tested and found to comply with the limits for a Class B digital device, pursuant to Part 15 of the FCC Rules. These limits are designed to provide reasonable protection against harmful interference in a residential installation. This equipment generates, uses and can radiate radio frequency energy and, if not installed and used in accordance with the instructions, may cause harmful interference to radio communications. However, there is no guarantee that interference will not occur in a particular installation. If this equipment does cause harmful interference to radio or television reception, which can be determined by turning the equipment off and on, the user is encouraged to try to correct the interference by one or more of the following measures:

Reorient or relocate the receiving antenna.

Increase the separation between the equipment and the receiver.

Connect the equipment into an outlet on a circuit different from that to which the receiver is connected.

Consult the dealer or an experienced radio/television technician for help.



## CHAPTER 1:

# GETTING TO KNOW YOUR BOAT REMOTE

The Boat Remote, Fig. 1.1, is a fully-programmable, environmental monitoring system that offers extensive on-site and remote monitoring capabilities for your boat. Designed for wall mounting, the Boat Remote is simple to install, program and operate. No changes to standard electrical or telephone service are required. Connected to a telephone line, Boat Remote will respond to an alarm by dialing up to eight separate telephone numbers. When the call is answered, an "Alert Condition" message is delivered in digitized speech.

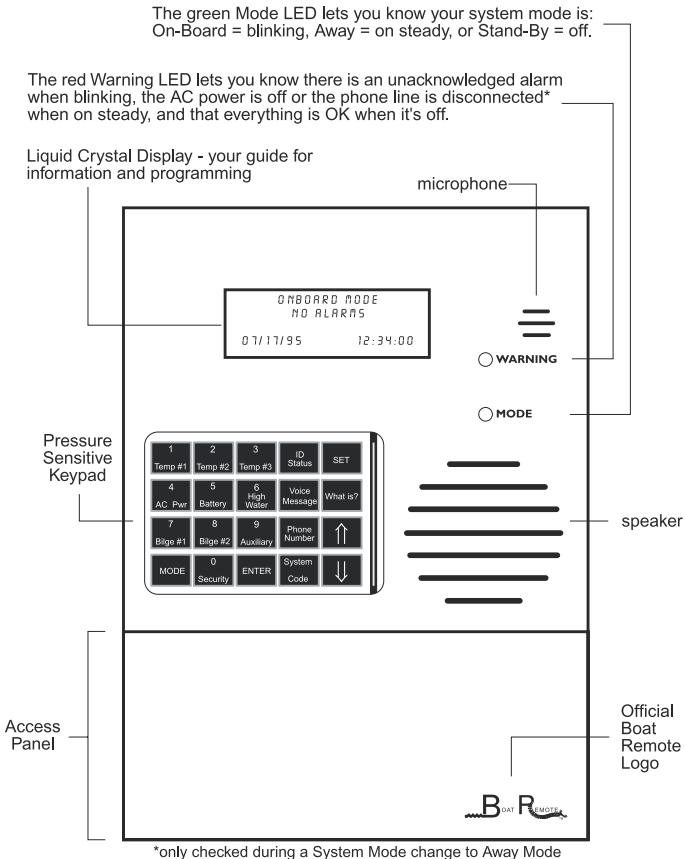

Fig. 1.1 The Boat Remote

The Boat Remote features extensive capabilities to monitor a variety of conditions:

- Bilge Pump Activity - 2 separate bilge pumps
- AC power failure
- 12VDC Battery level
- Temperature
- High Water
- Security

The Boat Remote is equipped with 6 predefined inputs, 2 undefined temperature inputs, and an auxiliary input. Additional sensors to help you customize Boat Remote for your needs can be added for extended monitoring in these areas:

- Intrusion or unauthorized entry
- Water leaks and seepage
- Temperature
- Humidity
- Equipment operation

And other conditions that may require unique monitoring solutions

The status of each monitored condition is readily obtained at the unit's installation site or remotely, by telephone. At the close of every Status Report, time is provided for listening to on-site sounds.

The Boat Remote features continuous updates on all monitored conditions via the scrolling display. In addition, bilge pump statistics are also displayed which can be used to set alarm parameters.

To ensure reliable operation, be sure to connect Boat Remote to your boat battery. In the event of AC power failure, the boat battery will continue to power the unit through the 12VDC input connection.

This manual is comprised of the instructions and commands for installing and operating the Boat Remote. Be sure to read them completely before starting your installation. The Programming chapter demonstrates step-by-step methods for utilizing the full range of available features. The Operation chapter provides application examples that explain how Boat Remote functions under various alarm conditions. The Troubleshooting chapter provides assistance in the event that problems are encountered.

## Technical Support

If any questions arise upon installation or operation of the Boat Remote, please contact Phonetics Customer Service Department, at the number shown below, and have the following information:

Date of Purchase \_\_\_\_\_

Serial number of your Boat Remote \_\_\_\_\_

Technical Support is available from 8:00 am to 5:00 PM, EST.

### ***Phonetics, Inc.***

901 Tryens Road, Aston, PA 19014

Phone: (610) 558-2700 FAX: (610) 558-0222

## Using the Keypad, LCD and LED Indicators

The keypad, Fig. 1.2 is used to program and access information from the Boat Remote. All programming is accomplished using simple key sequences and entering information with the number keys. Moving through menu options is performed with the arrow keys. The LCD display indicates which menu option has been selected. To change a parameter, enter the new value and press the ENTER Key.

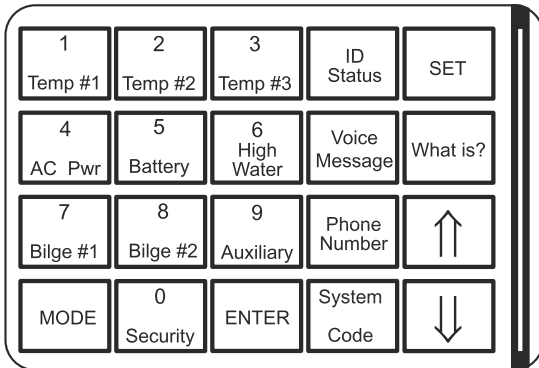

Fig. 1.2 The Keypad

## LCD (Liquid Crystal Display)

The LCD, local display, is your guide for information and programming. A scrolling status screen, referred to as the idle screen, will appear when the Boat Remote is idle. The status of all inputs that are in Status-Only Mode or Active Mode are shown on the idle screen. Inputs that are in Off Mode will not appear on the idle screen.

The Operating Mode, Date, and Time are on the first idle screen. Next, the Inputs will appear. The final idle screen will display the last alarm that has occurred, if one has occurred since the Boat Remote has been turned on.

## LEDs

The two LEDs are used to indicate the system operating mode and the alarm status of the Boat Remote. The "Mode" LED indicates the system operating mode of the Boat Remote and the "Warning" LED alerts you of a problem with the phone line, AC power or if an alarm exists. The LED indications are as follows:

## System Operating Mode

There are three Operating Modes that can be set for the Boat Remote: Stand-By, On-Board, and Away modes. The different modes change the way Boat Remote responds to an alarm condition. In Stand-By mode alarm dial out is disabled and local alarm messages are not recited through the speaker. In On-Board mode alarm dial out is disabled, but local alarm messages are recited. The unit will not answer the phone in Stand-By mode or On-Board mode. In Away mode the Boat Remote is fully operational. It will recite alarm messages, make alarm phone calls, and answer the phone for status reports.

To change the Operating Mode press the **MODE** key on the keypad until the appropriate mode is shown on the local display. The green LED will reflect the Operating Mode as follows:

The green light will be...

Off when the unit is in Standby Mode.

Blinking when the unit is in On-Board Mode.

On steady when the unit is in Away Mode.

## Warning LED

The Warning LED, red, alerts you of alarms, AC power disconnection, and phone line disconnection. The phone line connection is only checked when changing the Operating Mode to Away mode. The light reflects the following:

The red LED will be...

Off when everything is OK.

Blinking when an Unacknowledged alarm exists.

On steady when the AC power is off or the Phone Line is disconnected.

## Parts check list

### Boat Remote Package

Includes:

Boat Remote unit

power transformer

20' 3-conductor power cable

25' phone cord

mounting hardware

screwdriver

### Installation Kit

Includes:

float switch

20' 2-conductor float switch wire

20' 2-conductor battery wire

20' 1-conductor bilge pump wire





## CHAPTER 2: INSTALLATION

Correctly installing Boat Remote will ensure proper functioning of the unit. Please read the entire chapter before starting the installation process. **Failure to properly install the unit will result in erratic operation, shortened product life and a void warranty.**

Within the packaging will be a warranty registration card. Please take the time to fill this out and mail it. The One Year Limited Warranty is explained in the back of this manual.

### Operating Environment

The Boat Remote should be installed and operated in an area that provides space for wiring sensors to the unit, near an AC outlet and telephone line. The operating temperature range of the unit is  $-10^{\circ}\text{C}$  ( $14^{\circ}$  to  $122^{\circ}\text{F}$ ). Do not mount the unit in direct sunlight or in an area where it can get wet. The unit is designed to be mounted in a dry, interior area of your boat.

### Mounting

The Boat Remote is designed to be wall mounted using the four screws included. Attach two screws to the wall 5.3" apart, at the desired height from the floor. Place the Boat Remote over the two screws and slide the unit down. Remove the access panel and attach the remaining screws into the two holes in the interior area of the enclosure. Refer to Fig. 2.1.

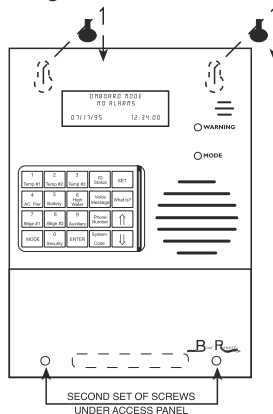

Fig. 2.1 Mounting the Boat Remote

## Connecting the Power Supply

There are two entry points for wiring into the enclosure of the Boat Remote. They are: a slot on the back of the enclosure below the access panel and a perforated "punch out" on the lower side of the enclosure. For a neat and clean installation, run your wires through the wall and have them enter the enclosure through the slot in the access panel area. Otherwise, remove the "punch out" and run the wires through this entry point. To remove the "punch out", take off the access panel and press on the outside of the enclosure, over the "punch out", with your thumbs until the plastic is removed.

The power transformer has three terminals that must connect to the Boat Remote. Use the 3-conductor cable included with the unit and start with the Boat Remote terminals. Attach the red and black wires of the cable to the 14VAC terminals on the Boat Remote. Refer to Fig. 2.2. Connect the uninsulated wire to the EG (Earth Ground) terminal. On the Transformer, connect the red and black wires to the end screws and connect the uninsulated wire to the center screw. Plug the transformer into an electrical outlet not controlled by a wall switch.

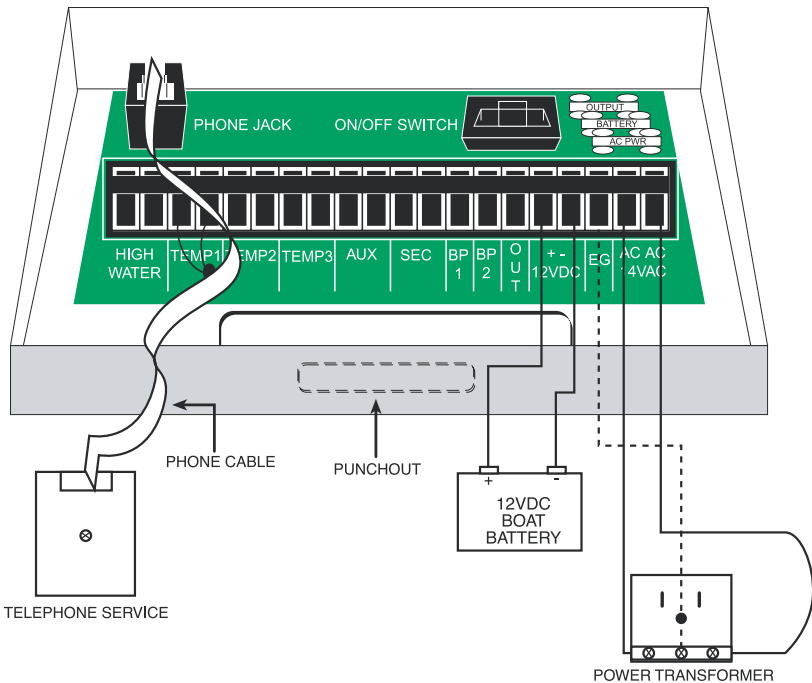

Fig. 2.2 Connecting Power and Telephone Service

## **Connecting the Battery**

The battery connection is for monitoring the voltage of your boat battery and it also provides power to the unit in the event of a power failure. The battery connects to the terminals labelled 12VDC.

If you have the Installation Kit, use the 2-conductor cable supplied. Otherwise, use a 2-conductor marine grade cable 16-22AWG. Attach the red wire to the positive (+) terminal on the Boat Remote and the black wire to the negative (-) terminal. At the other end of the cable attach the red wire to the positive terminal on the battery and the black wire to the negative (-) terminal. Refer to Fig. 2.2.

## **Connecting the Telephone Line**

Plug one end of the telephone line cord into the PHONELINE jack of the Boat Remote, and plug the other end into a modular wall jack. See Fig. 2.2.

## **Power Surge Protection**

The Boat Remote can be damaged by power surges and lightning through the telephone line and the 120 VAC power supply. Although the unit has built-in surge protection, we recommend that additional protection be obtained for the unit and for any electronic equipment that is attached to your power supply and telephone lines. Power surge protection is especially important if your boat is in a lightning prone area. The ISOTEL Surge Protector Model IB-4 is available through Phonetics. See Accessory Appendix.

## **Connecting Accessories**

### **High Water Float Switch**

The float switch is used to monitor for high water levels in the bilge. When choosing a location for the float switch, remember that its purpose is to alarm you when the water level has reached an unusually high or unacceptable level. Installing the float switch too low could cause frequent false alarms. We recommend the Rule model 33, this float switch will trip when the water level has reached 2 1/2" above the base of the switch. DO NOT connect the float switch to your bilge pump or battery. The float switch need only be connected to the Boat Remote to operate properly.

To mount the switch, follow these steps:

1. Place the switch on a horizontal, flat surface in the bilge, at the desired location.
2. Gently lift the float and mark the location of the front screw.
3. Move the switch away from the location mark and drive in one of the screws provided approximately 1/2" from the flat surface, so that the switch can easily slide under the head of the screw.
4. Slide the float switch under the head of the screw and then drive the second screw provided into the back screw hole, being careful not to overly tighten the screw as this may distort the switch and impair its operation.

Electrical:

Connect the wires from the float switch to the HIGH WATER terminals on the Boat Remote. Additional wire is included in the Installation Kit, or use 2-conductor 16-22AWG, to extend the wire from the float switch. Keep all wire connections above the highest water level. Cutting the switch wires may void the warranty and/or cause premature failure. All wire connections should be sealed with elastomeric sealant to prevent wire corrosion.

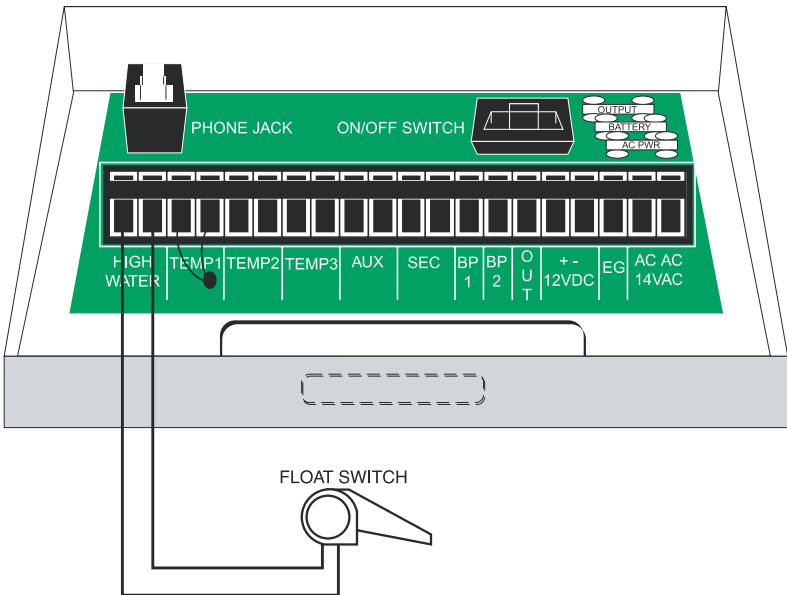

*Fig. 2.3 Connecting the High Water Float Switch*

## Temperature Sensors

Your Boat Remote comes with a temperature sensor connected to the TEMP1 input. This can be used to monitor the temperature where the Boat Remote is installed. Up to two additional sensors may be connected to the Boat Remote on the terminals labeled TEMP2 and TEMP3. The temperature inputs on the Boat Remote are compatible with industry standard 10K thermistors and are available in a wide range of application specific models. These include sensors for monitoring water, freezers, pipes and ducts.

*\*Contact Kele and Associates at (901) 382-4300 for temperature sensors and specify 10K Type 3 sensors.*

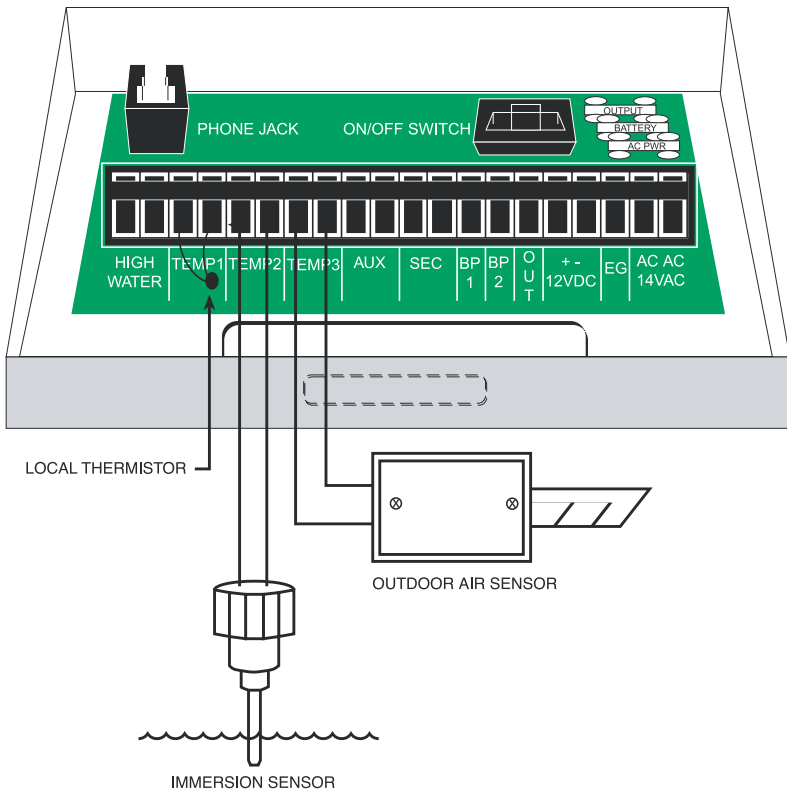

Fig. 2.4 Connecting Temperature Sensors

## Bilge Pump

The Boat Remote will monitor bilge pump activity when the positive power wire to the bilge pump is connected to the BP1 or BP2 inputs. This power connection can typically be made at any one of three locations:

1. At the bilge pump itself, where the positive power wire is connected.
2. At the float switch that controls the bilge pump, using the power wire that goes to the bilge pump.
3. At the console, where a bilge pump light may be located. Connect to the wire that goes to the bilge pump.

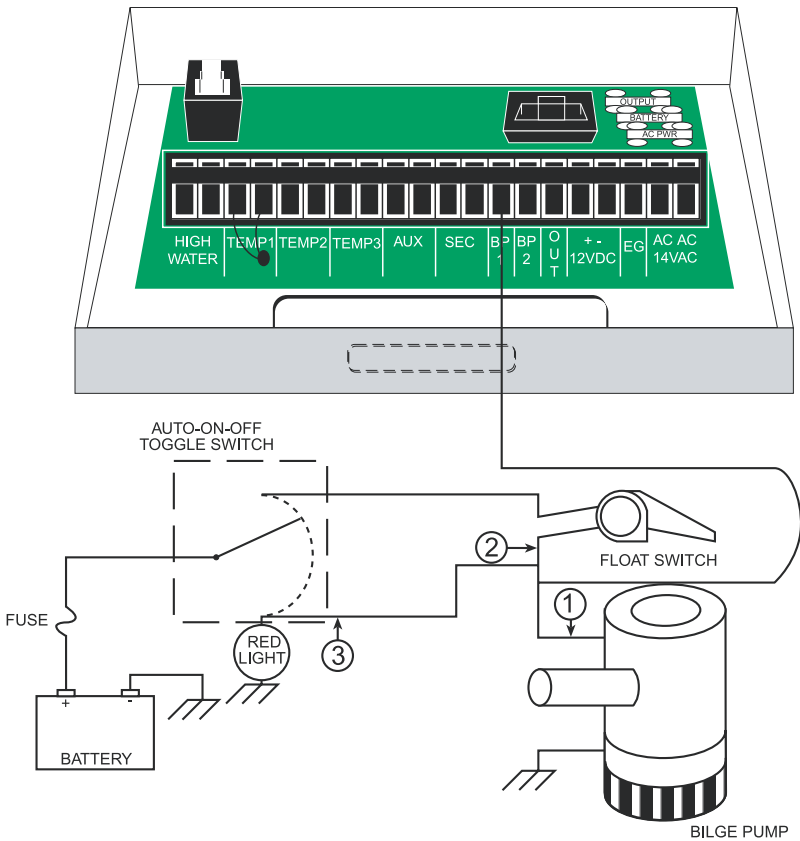
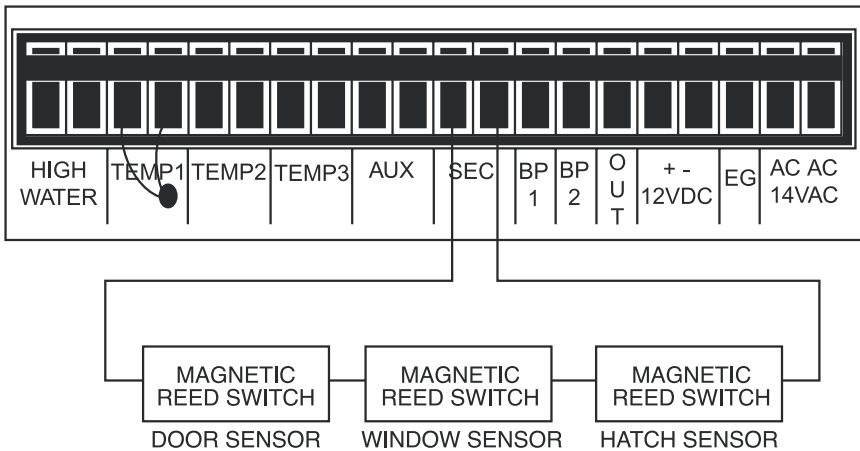

Fig. 2.5 Connecting the Bilge Pump

## Security Input

The security input can be used with magnetic reed switches, passive infrared detectors or any other security device that provides a normally open or normally closed contact. The security input may have several normally closed accessories attached in a chain. If the contact on any of the accessories on the chain opens, the input will go into alarm.

To install an accessory to the security input follow the diagram below:



*Fig. 2.6 Connecting Accessories to the Security Input*

## Auxiliary Input

The auxiliary input can be used to monitor any normally open or normally closed contact. For example, you may have other equipment that can produce an alarm output when certain conditions go out of range. Such equipment may detect water depth, wind speed, etc.

To install an accessory to the auxiliary input follow the diagram on the following page, Fig. 2.7.

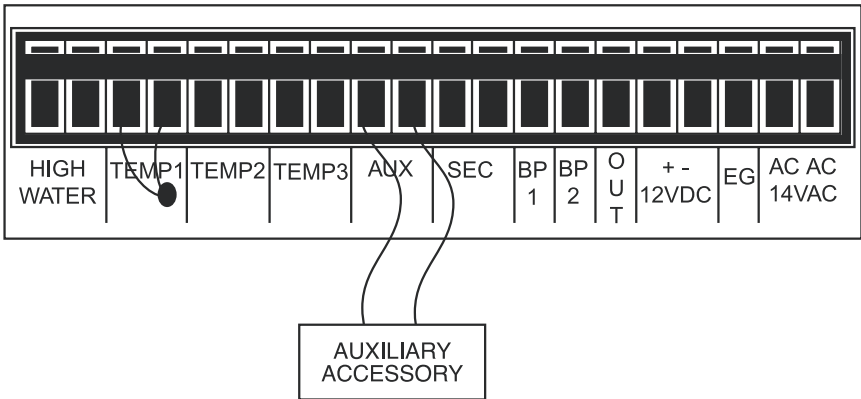

Fig. 2.7 Connection to the Auxiliary Input

## Output

The Boat Remote features a switched 12V output signal that can be used to turn on a siren or strobe light when an alarm occurs. The power for the output is derived from the boat battery. This allows the output to function in the event of a power failure. The figure below shows how a strobe light would be connected to the output terminal. The negative terminal from the light or siren must connect to the boat ground (or the negative terminal of the boat battery). The output can be programmed to trip if any alarm occurs or if the security alarm only occurs. See Chapter 3 for programming the output.

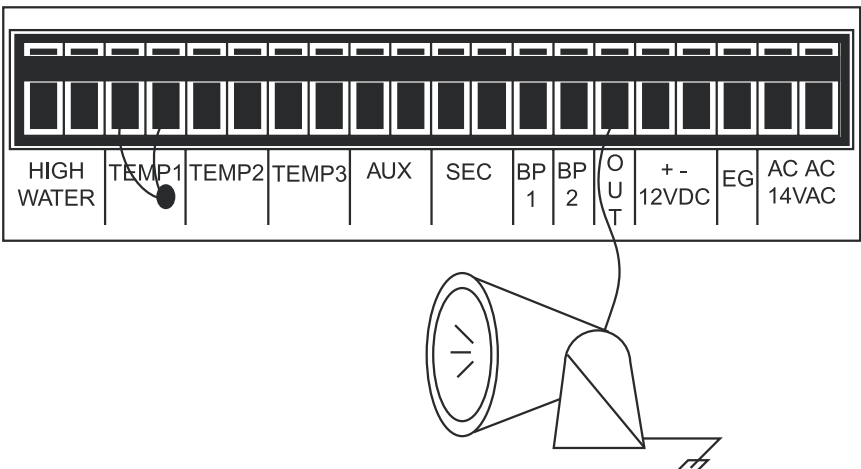

Fig. 2.8 Connecting a Strobe Light to the Output



## CHAPTER 3:

# PROGRAMMING

This chapter describes use of the keypad and explains the keypad commands for programming the Boat Remote. You will learn how to program Voice Messages, System Parameters, Phone Parameters, and Input Alarm Parameters.

### Using the Keypad, LCD and LED Indicators

The keypad is used to program and access information from the Boat Remote. All programming is accomplished using simple key sequences and entering information with the number keys. Moving through menu options is performed with the arrow keys. To change a parameter, enter the new value and press the ENTER key.

The LCD, liquid crystal display, indicates which menu option has been selected and the current selected parameter.

The two LED's are used to indicate the system operating mode and alarm status of the Boat Remote. The MODE LED indicates the system operating mode of the Boat Remote. The WARNING LED alerts you if there is a problem with the phone line, AC power or if an alarm exists. The following describes the LED indicators:

**MODE LED - GREEN**  
*Off = Stand-By Mode*  
*Blinking = On-board Mode*  
*On Steady = Away Mode*

**WARNING LED - RED**  
*Off = Everything OK*  
*Blinking = Unacknowledged Alarm Exists*  
*On Steady = AC Power Off or Phone Line Disconnected*

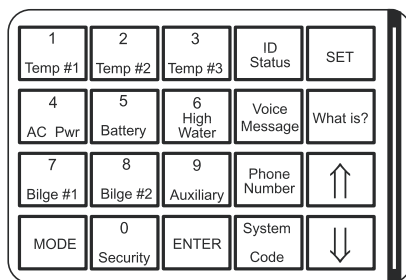

Fig. 3.1 The Keypad

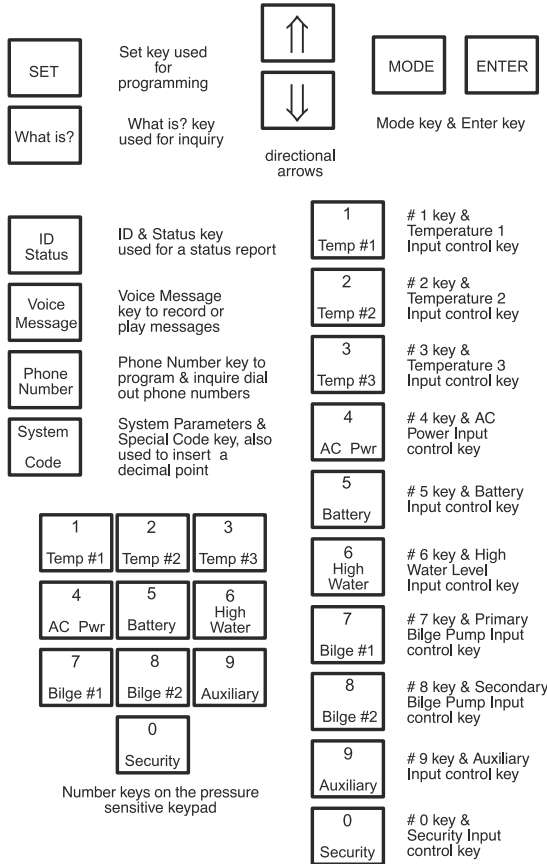

Fig. 3.2 The Keypad Keys and Their Functions

## The Keys

In the figure above, please note the keys on the keypad are grouped by function. The number keys are arranged as they are on a telephone for ease of use. They are also used as the 10 input keys. The four operations keys: ID, VOICE MESSAGE, PHONE NUMBER, AND SYSTEM, are used to program and inquire operation parameters, i.e. tone or pulse dialing. The CODE key is used for special codes to be explained in the Dial Out section. The SET and WHAT IS? keys, along with the MODE and ENTER keys will be the most prominently used to make your programming choices. And the directional ARROW KEYS are for scrolling through the menu screens. Refer to the following programming examples for more details.

## PROGRAMMING VOICE MESSAGES

Boat Remote allows you to record four custom alarm messages and an identification (ID) message. The four alarm messages are for the Temperature #1, Temperature #2, Temperature #3, and Auxiliary inputs. If a message is not recorded for one of the above a default message will be used. User recorded messages are replaced by default messages when the unit is reset. (See Troubleshooting)

### Recording a Voice Message

To record a message, follow the example below for ID message and replace the ID STATUS key with the key representing the message you would like to record. For example, replace the ID key with the TEMP #1, TEMP #2, TEMP #3, OR AUXILIARY key. \*You have 5 seconds to record your message for temperatures 1, 2, and 3. You have up to 10 seconds for the auxiliary and ID messages. If you have finished speaking your message before the recording time is expired, you can stop recording by pressing the ENTER key.

### Unit ID Message

The Unit ID Message is the identification of your Boat Remote. The purpose of the Unit ID Message is to immediately provide the source of the call, especially when using the same Dial Out Phone Number(s) for more than one Boat Remote. When the Boat Remote is called from a remote location or dials out during an alarm, it always begins its message with the Unit ID Message: "Hello, [your recorded ID message.]" OR, the default message, "Hello, this is Boat Remote."

### To record ID message

Press the SET key on the keypad.



Press VOICE MESSAGE.



Press the ID STATUS key on the keypad.



Wait for the beep and then begin speaking. You are then given 10 seconds\* to recite your message into the Boat Remote built-in microphone. Sample ID message:

*"Hello, this is the King Crimson docked at the Big Fish Marina."*

### Temperature #1, #2, or #3 Input message

These voice messages allow the recipient of an alarm dial out phone call to distinguish which temperature input is in alarm. Sample:

*"The temperature in the salon..."*

### Auxiliary Input message

This voice message differentiates the auxiliary input from other inputs. It also allows for a description of the alarm in progress to an alarm dial out recipient who may be unfamiliar with the Boat Remote auxiliary accessory. Sample:

*"The hatch is open."*

## PROGRAMMING SYSTEM PARAMETERS

The Boat Remote allows you to adjust system parameters for greater flexibility. The system parameters include: Maximum Number of Calls, Call Delay, Intercall Delay, Dialing Method, TAD, Voice Repetitions, Rings Until Answer, Listen In, Speaker, Temperature, Output Settings, and Current Time & Today's Date. Program the following individual parameters to your needs. To program each parameter, enter the desired values by pressing the appropriate number keys when prompted by the on-screen display. Then, press **ENTER** and the display screen will prompt you for the next parameter. If you wish to keep an existing value for any of the parameters, simply scroll past it using the down arrow. If you do not know the current values simply press the **WHAT IS?** and the **SYSTEM** key, before entering the Set System menu.

**\*Use the down arrow to scroll through each parameter.** If you pass the parameter you wish to set, scroll through the remaining parameters and start over by pressing **SET SYSTEM** again. You cannot scroll up in this menu by using the up arrow.

Once you've pressed the number keys to get the appropriate value or toggled to your choice by pressing the **MODE** key, then press **ENTER**. You must press **ENTER** here or the previous setting will remain. After pressing **ENTER**, you will then be able to set the next parameter, or

scroll through the rest of the menu using the down arrow.

Press the SET key on the keypad.



Press SYSTEM.



The Local Display will prompt you to set the following System Parameters:

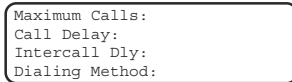

## Maximum Number of Calls

The Maximum Number of Calls feature controls the total number of repeated calling attempts by the Boat Remote in the event of an alarm. When an alarm occurs, the dial out process begins, and Boat Remote continues to cycle through your programmed phone selection until the maximum number of calls is reached

Maximum Number of Calls is cancelled when an alarm is acknowledged. If the Maximum Number of Calls is completed and no alarm acknowledgment has occurred, the Boat Remote will automatically acknowledge any alarm and stop the dial out.

The Maximum Number of Calls setting regulates the number of calls that will be made as a result of any alarm; if more than one alarm is detected at once, or if a second alarm occurs during dial out on the first alarm, the Maximum Number of Calls setting will start the calling process from zero, until the programmed number of calling attempts are completed.

\*In the event that only one phone number is programmed for dial out, the Boat Remote will automatically stop dial out at 15 calls, in accordance with FCC regulations.

### Program Max Calls

The default setting for Max Calls is 100 calls, but may be programmed from 0 to 255 calls. If set at 0, no calls will be made.

Use the number keys.

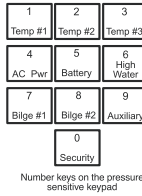

Press ENTER.



## Call Delay

Call Delay is the programmed length of time the Boat Remote waits, following detection of an alarm, before it begins dial out. This applies only to the first call. During this time Boat Remote will audibly repeat the alarm message. For delay time between calls refer to Intercall Delay. The Call Delay range is 0 - 999.59 minutes and the default is 30 seconds. To set the Call Delay time, press the number keys corresponding to the number of minutes and press ENTER, repeat to enter seconds.

Use the number keys.

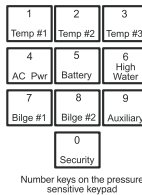

Press ENTER.



## Intercall Delay

This parameter is the programmable amount of time Boat Remote will wait after hanging-up one dial out phone call and before dialing the next phone number, during an alarm dial out. Intercall Delay is activated **only after alarm dial out to the first telephone number fails to be acknowledged**. This period can be programmed from 30 seconds to 999 minutes 59 seconds. The default intercall delay time

is 1 minute.

To set the intercall Delay time, press the number keys corresponding to the number of minutes and press ENTER, repeat to enter seconds.

Use the number keys.

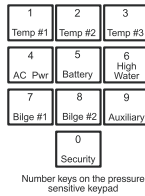

Press ENTER.



If an incoming telephone call is made to the Boat Remote during the Intercall Delay (in between its dialing of subsequent telephone numbers to report an alarm), it will answer the incoming call and immediately report any existing alarms. The manner in which the incoming call is answered depends upon whether or not TAD (Telephone Answering Device) is enabled or disabled:

If TAD is enabled, rings until answer will be 1.

If TAD is disabled, rings until answer will be 10.

\*Refer to Rings Until Answer and TAD sections in this chapter.

## Dialing Method

Boat Remote can dial out in either pulse or Touch Tone™. Select the type of dialing depending upon the type of service provided by your telephone company. The display will prompt you to choose Pulse or Tone dialing. The default is Tone. Toggle between pulse and Tone by pressing the MODE key while in the Set System menu. Press ENTER when your choice is displayed.

Press MODE.



Press ENTER.



The local display will prompt you to enter the following System Parameters:

```
TAD:
Voice Repts:
Rings to Answer:
Listen In (sec):
```

## TAD (Telephone Answering Device)

The TAD feature is especially useful because it integrates the operation of the Boat Remote with your telephone answering device, i.e. answering machine, in a way that retains the full flexibility of each system. This allows you to have on-demand telephone access to your Boat Remote, for obtaining a Status Report, while your telephone answering device is set to receive outside calls. Programming Boat Remote for use with a telephone answering device (TAD) is always used in conjunction with Rings Until Answer.

\*The TAD feature only applies to answering devices connected to the same telephone line as the Boat Remote.

### Program TAD

You can turn TAD on or off, the default is off. While in the Set System menu, turn on or off the TAD feature by pressing the `MODE` key. When your choice is displayed press `ENTER`.

Press `MODE`.

```
MODE
```

Your choice appears on the local display.

```
TAD: ON
```

Press `ENTER`.

```
ENTER
```

### Using the TAD Feature

1. Make sure the TAD feature is **enabled**. (The default setting is **disabled**, so you must enable it first.)
2. Determine the number of rings your telephone answering device (TAD) uses to answer the telephone. (Most answering devices require 4 rings; others are selectable.)
3. Program rings until answer to a greater number than the number of rings set on your answering machine.



**Example:**

Answering Device: rings = 4

Boat Remote: rings until answer = 6

Using the procedure just outlined, all incoming calls will be answered by the telephone answering device, allowing it to operate normally. With the programming just accomplished, the Boat Remote can be accessed remotely, by telephone, to obtain a status report.

1. Dial the telephone number of the Boat Remote.
2. Let the telephone ring once and then hang up.
3. Wait approximately ten seconds.
4. Call the Boat Remote back. It will answer the telephone on the first ring.

**Explanation:** The pattern of one ring followed by a second call (within 30 seconds), signals the Boat Remote to answer your incoming call, excluding the telephone answering device.

**Exception:** If the Boat Remote shares the same line with a telephone answering device, and frequent incoming calls are expected on that line during a specific time, then you may want to temporarily disable the TAD feature. If you leave the TAD enabled, it will not adversely affect normal operation, but if two outside telephone calls are received within the same 30 second time window, the Boat Remote will interpret this pattern as a signal to answer the telephone. If this occurs, press any key on the Boat Remote to hang up.

## Voice Repetitions

The Voice Repetitions feature allows programming of the number of times the alarm message is delivered **per phone call** during alarm dial-out.

The maximum alarm message repetitions may be set to 10. The default is 3 repetitions. Use the number keys to type the desired number of voice repetitions and press ENTER.

Use the number keys.

1 Temp #1	2 Temp #2	3 Temp #3
4 AC Pwr	5 Battery	6 High Water
7 Blige #1	8 Blige #2	9 Auxiliary
0 Security		

Number keys on the pressure sensitive keypad

Press ENTER.



## Rings until answer

Rings Until Answer is the programmed number of times the telephone rings before the Boat Remote will answer an incoming call. Boat Remote will answer incoming calls only when in Away mode. If using a telephone answering device (TAD) please refer to the TAD section before programming rings until answer.

To set the number of rings until answer, use the number keys to enter the desired number of rings and press ENTER. The range is from 1 to 50 rings. The default value is 1.

Use the number keys.

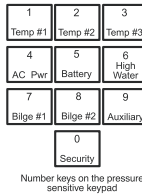

Press ENTER.



## Listen In

The Listen-in Time is the amount of time you can listen to sounds from the Boat Remote's built-in microphone at its installation site. When you call in for a Status Report, the Boat Remote announces the Listen-in Time at the end of its status reading:

*"Listen to the sound level for (programmed time)."*

The programmable time range is from 0 to 255 seconds. The default is 15 seconds.

To program the Listen-in Time, using the number keys, enter the seconds. The Boat Remote will display the digits as they are pressed.

Use the number keys.

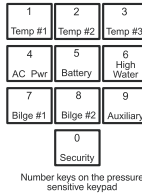

Press ENTER.



The local display will prompt you to enter the following System Parameters:

```
Speaker:  
Temperature:  
Output Trigger:  
Output Mode:
```

```
Current Time  
Today's Date  
Year:
```

## Speaker

When the Boat Remote dials out to report an alarm, it also recites the alarm message on the boat during the call delay period. This feature allows you to turn on or off the voice at the site of the boat during alarm dial out. Turn the speaker off to prevent intruders or unauthorized persons from hearing the alarm dial out message. Use the MODE key to toggle between on and off and then press ENTER when your choice is displayed. The default is on.

Press MODE.



Press ENTER.



## Temperature

Choose the units of measure for the temperature inputs, either degrees Celsius (°C) or Fahrenheit (°F). The default is Fahrenheit

(°F). Toggle between Celsius and Fahrenheit by pressing the **MODE** key while in the Set System menu when Temperature is displayed. Press **ENTER** once your choice is displayed.

Press **MODE**.



Press **ENTER**.



## Output Trigger & Output Mode

The output terminal will provide 12V power to an accessory when alarms occur. The Output Trigger can be programmed to trigger the output if any one of the inputs is in alarm or if the security input only is in alarm. The Output Trigger default is set to trigger for the security input only. To change the Output Trigger press the **MODE** key until your choice is displayed and then press **ENTER**.

Press **MODE**.



Press **ENTER**.



The Output Mode determines whether the output trips in Away mode only or in both Away mode and On-Board mode. The default is set for Away Mode only. To change the Output Mode, press the **MODE** key, while in the Set System menu, until your choice is displayed.

Press **MODE**.



Press **ENTER**.



## Current Time & Today's Date

The real-time clock is a necessary element of your Boat Remote. The alarm recognition time, call delay, and bilge pump cycle rate are all based on this built-in clock. The clock runs on military time and the date is month and day only. The default is 0:00 am, 1/1.

To program the time, use the numbers keys to enter the hour. Press ENTER. Use the number keys to enter the minutes. Press ENTER.

Use the number keys.

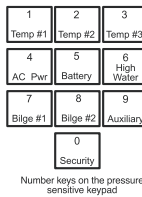

Press ENTER.



To program the date, use the number keys to enter the month. Press ENTER. Use the number keys to enter the day. Press ENTER. Use the number keys to enter the last two digits of the year. Press ENTER.

Use the number keys.

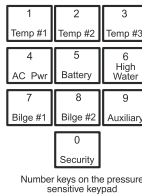

Press ENTER.



## DIAL OUT PHONE NUMBERS

The Boat Remote can store up to eight different phone numbers, 32 digits each, for dial out. Each input can be programmed to selectively dial any of those 8 phone numbers during an alarm dial out. In the event of an alarm, the numbers are dialed sequentially, 1-8. Boat

Remote automatically will wait until outgoing calls are answered before reciting alarm messages.

You have the ability to set a different dial out list for each input with Boat Remote. A dial out list is a list of up to eight phone numbers, for each input, to be called in the event of an alarm. Although, each dial out phone number may be used only once for each input.

## Programming the Dial Out Phone Numbers

Press SET.



Press PHONE NUMBER.



Press a number key to indicate the sequence number, 1-8, of the dial out phone number that you now wish to program. The sequence number (1-8) denotes the order in which the numbers will be dialed during an alarm. For example, press 1 for the first person to be called in the event of an alarm, 8 for the last person to be called in the event of an alarm, and so on.



Next, you will be prompted to enter the actual phone number. Enter the actual phone number using the number keys on the keypad. Enter the complete telephone number (1 + area code, if necessary) using the number keys. The Boat Remote will display the digits as they are pressed.

For a new number to be recognized you must press ENTER after typing the new number with the number keys.

To erase a phone number press ENTER before pressing any number keys and the existing phone number will be erased. Press the down arrow and the existing phone number will be kept.

Use the number keys.

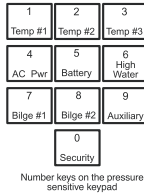

The digits will be displayed as they are pressed.

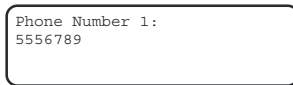

Press the ENTER key on the keypad.



Next, you will be prompted to choose the dialing mode, voice or beeper, for each phone number. When you select beeper a voice message will not be recited over the phone, unless you use the voice message special code. See Special Codes, this chapter.

To toggle between voice or beeper press MODE.

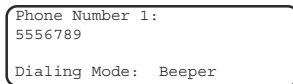

Press ENTER.



NOTE: In the event that only one phone number is programmed, the Boat Remote will limit the maximum number of calls to 15, regardless of the Maximum Number of Calls programmed, in accordance with FCC regulations.

## Special Dialing

The Boat Remote has provisions for special dialing sequences.

Special dialing sequences allow:

- Dialing that requires an access number to connect with an outside line.
- Dialing that requires the pound (#).
- Dialing to a beeper or pager.

Incorporate a special code into your phone number entry by following the combinations explained below.

## Special Dialing Keys

The following designated keys represent special functions when used with Phone Number entries:

1. code + 1 will cause the Boat Remote to wait until the outgoing call has been answered before continuing to dial the remaining programmed numbers.

When inquiring telephone numbers, a code + 1 combination is displayed as a W.

2. code + 2 creates a 2 second pause.  
PAUSE represents a two second pause in dialing.

When inquiring telephone numbers, PAUSE is displayed as a P.

3. code + 3 will cause the Boat Remote to give a voice report and hang-up.

When inquiring telephone numbers, voice and hang-up is displayed as a V.

4. code + 4 will cause the Boat Remote to dial a # tone. This is sometimes required at the end of the phone number for some beeper systems.

When inquiring telephone numbers, this code is displayed as a #.

5. code + 5 will make the Boat Remote wait for a dial tone before continuing to dial the dial out phone number. This is useful with some phone systems. For example, it can be used when an access number is required before dialing to an outside line. (i.e. in some cases a "9" or other number must be dialed first in order to get a dial tone for an outside line.)

When inquiring telephone numbers, this code is displayed as a D.

NOTE: Each time a pause, pound (#), or one of the code key



combinations is incorporated into a phone number, it is counted as one digit toward the total of 32 digits allowed per dial out phone number.

## Dialing to a Beeper or Pager

The following example demonstrates just one solution to programming the Boat Remote for dialing to a beeper or pager. Many other key sequences will also work. Start with steps 1–3 below; next, enter special dialing keys where required for your beeper or pager service.

1. Press SET.
2. Press PHONE NUMBER.
3. Press any unassigned number key (from 1 to 8) to represent the new telephone number entry.
4. Enter the complete telephone number using the number keys.
5. Press CODE + 1. This instructs the unit to wait for the telephone call to be answered by the beeper or pager service.
6. Now press CODE + 2 to activate a two second pause. This assumes the call is answered by a beeper/pager service that immediately delivers a prerecorded voice message. The PAUSE special code may be entered more than once to program more time for the beeper/pager service to finish its message. Each entry of the PAUSE special code allocates two additional seconds. The Boat Remote will “beep” with each entry.
7. Enter a telephone number or custom code number that will identify the Boat Remote as the caller to your beeper or pager. A code may consist of any number(s) you designate. Many users find it convenient to use the telephone number to which the Boat Remote is connected.
8. A pound may be required in some dialing situations. If required, position the pound (#) within the telephone number where required by pressing the pound special code, CODE + 4. The unit will “beep” each time the pound (#) special code is entered.
10. Press ENTER.

### Example



16105581212WPP3116655#

## INPUTS

In preparing the Boat Remote to sense an alert condition several parameters must be configured for each input. The following paragraphs describe these important parameters.

### **Input Mode: Active, Off, Status Only**

An input configured in the Active Mode will be enabled to dial out for alarms, show its status in the scrolling display, and also have its status reported during call-in.

An input configured in the Off Mode will be totally disabled. It will not dial out for alarms, show its status in the scrolling display, nor be reported during a remote status report.

An input configured in the Status-Only Mode will not dial out, but its status will show in the scrolling display and it will be reported during a status report.

### **Input Dial Out Phone Selection**

The Input Dial Out Phone Selection is the list of phone numbers that will be called if an alarm occurs for that input. This list may include one or more of the phone numbers programmed by you for the Dial Out Phone Numbers (1-8). Boat Remote will dial the numbers sequentially (1-8), regardless of what order you enter them in the Input Dial Out Phone Selection.

### **Recognition Time (not for Bilge #1 & #2)**

This is the programmable waiting period to determine if an alert condition has persisted long enough to be considered a valid alarm. If the sensor returns to normal within the Recognition Time, then no alarm will occur.

In addition to these parameters each input requires levels, time constraints, or other conditions for you to set. This section of the manual along with the local display will guide you through programming. Please read through this section before you begin to program. Consider the choices that follow for each input and how they apply to your needs.

To keep previous settings scroll to the next parameter with the down arrow key. To clear an input phone selection press **ENTER** before pressing any numbers for that phone selection, while in an Input menu. When changing a parameter press **ENTER** when your choice appears on the display. Press the down arrow one extra time, once you have reached the end of an input menu, to reach the idle screen.

## AC Power Input

To program the alarm parameters for the AC power input follow these steps:

Press the SET key on the keypad.



Press the 4 AC PWR key on the keypad.



The Input Mode will be displayed. The default is Active. To change the Input Mode press the MODE key on the keypad until the Input Mode you want is displayed. The available Input Modes are Active, Off, or Status.

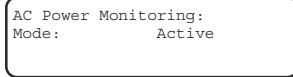

Press the MODE key to toggle through the three input modes.



Press ENTER.



The display will prompt you to enter an alarm recognition time, the range is from 1 second to 999 minutes 59 seconds, default is 5.0 minutes. Use the number keys to enter the minutes. Press ENTER. Next, enter the number of seconds. Press ENTER.

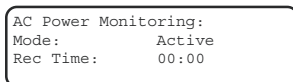

Use the number keys.

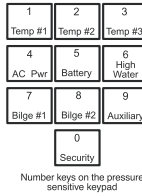

Press ENTER.



The display will prompt you to enter the AC Power Input phone selection. Use the number keys to select the phone numbers to be dialed when the AC Power Input is in alarm. You can choose all of the eight numbers that you programmed for dial out, or any combination of the eight numbers. Remember, regardless of what order you enter your Input phone selections, the phone numbers will be dialed in order, according to their sequence number (1-8). The display will reflect this.

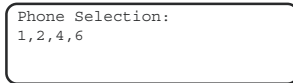

## Battery Input

To program the alarm parameters for the Battery Input, follow these steps:

Press SET.



Press BATTERY.



The Local Display will prompt for the High and Low Voltage Limits. Using the number keys on the keypad enter the High Limit. The default is 15.5V and the range available is 0-16 Volts. Use the CODE key to insert a decimal point.

Use the number keys.

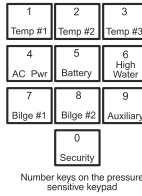

Use the CODE key to insert a decimal point.



Press ENTER.



Using the number keys on the keypad enter the Low Limit. The default is 11.0V and the range is 0-16 Volts. Use the CODE key to insert a decimal point.

Use the number keys.

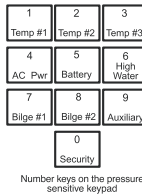

Use the CODE key to insert a decimal point.



Press ENTER.



Using the number keys on the keypad enter the Alarm Recognition Time in minutes and seconds. The range is from 1 second to 999 minutes 59 seconds. The default is 5.0 minutes. Use the number keys to enter the minutes and press ENTER. Then, repeat for seconds.

Use the number keys to enter minutes and seconds.

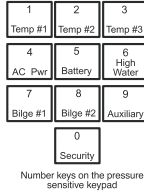

Press ENTER.



The Input Mode will be displayed. The default is Active. Press the MODE key on the keypad until the appropriate mode is shown on the display.

Press the MODE key to toggle through the three input modes.



Press ENTER.



The display will prompt you to enter the Battery Input phone selection. Use the number keys to select the phone numbers to be dialed when the Battery Input is in alarm. You can choose all of the eight numbers that you programmed for dial out, or any combination of the eight numbers. Remember, regardless of what order you enter your Input phone selections, the phone numbers will be dialed in order, according to their sequence number (1-8). The display will reflect this.

Use the number keys.

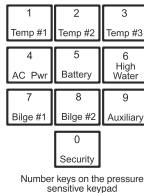

Press ENTER.



The display will reflect your selection.

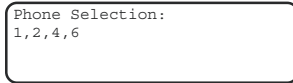

### Temperature Inputs (1, 2, & 3)

The Temperature Inputs are compatible with the industry standard 10K thermistors. The monitored temperature range is -20°F to 160°F, -29°C - 71°C.

To program the Temperature Inputs:

Press SET.



Press TEMP #1, TEMP #2, OR TEMP #3.

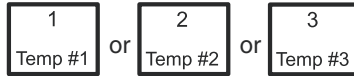

The local display will prompt for High Limit and Low Limit. Using the number keys on the keypad enter the High Limit. The default is 100°F. Use the CODE key to insert a decimal point.

Use the number keys.

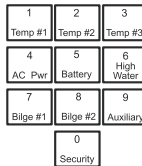

Number keys on the pressure sensitive keypad

Use the CODE key to insert a decimal point.



Press ENTER.



Using the number keys on the keypad enter the Low Limit. The default is 40°F. Use the CODE key to insert a decimal point.

Use the number keys.

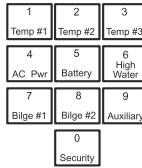

Number keys on the pressure sensitive keypad

Use the CODE key to insert a decimal point.



Press ENTER.



Using the number keys on the keypad enter the Alarm Recognition Time in minutes and seconds. The range is from 1 second to 999 minutes 59 seconds. The default is 3 seconds.

Use the number keys to enter minutes.

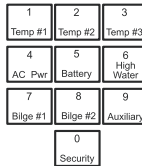

Number keys on the pressure sensitive keypad

Press ENTER.



Repeat for seconds.



Press the **MODE** key on the keypad until the appropriate mode is shown on the display. The default for Temperature Input #1 is Active. The default for Temperature Inputs #2 and #3 is Off.

Press the **MODE** key to toggle through the three input modes.



Press **ENTER**.



The display will prompt you to enter the Temperature Input phone selection. Use the number keys to select the phone numbers to be dialed when the Temperature Input is in alarm. You can choose all of the eight numbers that you programmed for dial out, or any combination of the eight numbers. Remember, regardless of what order you enter your Input phone selections, the phone numbers will be dialed in order, according to their sequence number (1-8). The display will reflect this.

Use the number keys.



Press **ENTER**.



The display will reflect your selection.

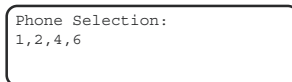

## Bilge Pump Inputs (2)

The Bilge Pump Inputs will monitor the number of on/off cycles and the accumulated run time of your bilge pumps. The alarm parameters can be programmed to detect whether the bilge pump runs too frequently (cycle rate alarm) or for too long a period (maximum run time alarm). To aid in determining the appropriate alarm parameters for your boat, set the input mode to status only and monitor the display for a day or so. It will show bilge pump activity as follows:

Bilge Pump 1	OFF
Cycle: 0	Time:0:00
Max Cycle Rate:	0
Max Runtime:	0:00

1. The real time status, on or off, of the bilge pump.
2. Number of cycles and accumulated run time over a 24 hour period starting at 12 am. (This resets to 0 at 12 am)
3. Maximum # of cycles over the programmed cycle rate alarm period.
4. Maximum run time of any one cycle.

To program the bilge pump alarm parameters:

Press SET.



Press BILGE #1 or BILGE #2.

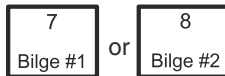

The input mode will be displayed. Press the MODE key on the keypad until the appropriate mode is shown on the display. The default for bilge #1 is active. The default for bilge #2 is off. Press ENTER.

Press the MODE key to toggle through the three input modes.



Press ENTER.



The local display will prompt for the Maximum Run Time. Using the number keys on the keypad, enter the number of minutes, press ENTER. Repeat for seconds. The default is 30 minutes and the range is 1 second to 999 minutes 59 seconds.

Use the number keys to enter minutes.

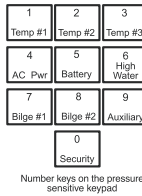

Press ENTER.



Repeat for seconds.

The local display will prompt for the Cycle Rate alarm parameters. The cycle rate alarm will trip whenever the number of on/off cycles of the bilge pump exceeds the programmed time period. The default is 20 cycles/1 hour. The programmable range is 0 - 120 cycles/1 - 24 hours. A setting of 0 cycles disables the cycle rate alarm.

Using the number keys on the keypad enter the number of cycles, press ENTER. Type in the number of hours, press ENTER.

Use the number keys to enter the number of cycles.

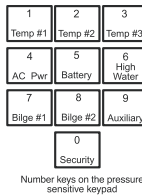

Press ENTER.



Repeat for hours.

The display will prompt you to enter the Bilge Pump Input phone selection. Use the number keys to select the phone numbers to be dialed when the Bilge Pump Input is in alarm. You can choose all of

the eight numbers that you programmed for dial out, or any combination of the eight numbers. Remember, regardless of what order you enter your Input phone selections, the phone numbers will be dialed in order, according to their sequence number (1-8). The display will reflect this.

Use the number keys.

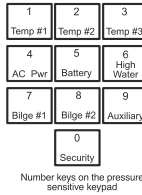

Press ENTER.



The display will reflect your selection.

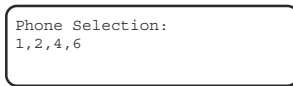

The last item the unit asks you is if you want to reset the bilge pump data, accumulated run time and cycle rate. Using the MODE key, toggle between Y and N, yes and no, for the Reset Bilge Data. If you wish to clear all accumulated bilge pump data at this time, press ENTER when the Y for yes is displayed. This feature will reset the accumulated run time and accumulated cycle rate and will begin to accumulate the data again, starting now.

Press MODE.



Press ENTER.



## Emergency High Water Level Input

The High Water Level Input will monitor the open or closed status of a float switch. To program the Emergency High Water Level Input, follow these steps.

Press SET.



Press HIGH WATER.



Using the number keys on the keypad enter the Alarm Recognition Time, minutes and seconds. The range is from 1 second to 999 minutes 59 seconds. The default is 5 minutes.

Use the number keys to enter minutes.

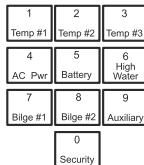

Number keys on the pressure sensitive keypad

Press ENTER.



Repeat for seconds.

The Input Mode will be displayed. The default is Active. Press the MODE key on the keypad until the appropriate mode is shown on the display.

Press the MODE key to toggle through the three input modes.



Press ENTER.



The display will prompt you to enter the Emergency High Water Level Input phone selection. Use the number keys to select the phone numbers to be dialed when the Emergency High Water Level Input is in alarm. You can choose all of the eight numbers that you programmed for dial out, or any combination of the eight numbers. Remember, regardless of what order you enter your Input phone selections, the phone numbers will be dialed in order, according to their sequence number (1-8). The display will reflect this.

Use the number keys.

1 Temp #1	2 Temp #2	3 Temp #3
4 AC Pwr	5 Battery	6 High Water
7 Bilge #1	8 Bilge #2	9 Auxiliary

0  
Security

Number keys on the pressure sensitive keypad

Press ENTER.



The display will reflect your selection.

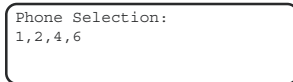

## Auxiliary Input

The Auxiliary Input is a dry contact detection circuit that monitors the open or closed status of any normally open or normally closed accessory item. To program the Auxiliary Input:

Press SET.



Press AUXILIARY.



The Local Display will prompt for you to choose normally open or normally closed. The default is normally open. Use the MODE key to toggle between open and closed. When your choice is displayed press ENTER.

Press the MODE key to toggle between open and closed.



Press ENTER.



Using the number keys on the keypad enter the Alarm Recognition Time, minutes and seconds. The range is from 1 second to 999 minutes 59 seconds. The default is 3 seconds.

Use the number keys to enter minutes.

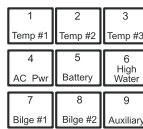

Number keys on the pressure sensitive keypad

Press ENTER.



Repeat for seconds.

The Input Mode will be displayed. The default is Off. Press the MODE key on the keypad until the appropriate mode is shown on the display.

Press the MODE key to toggle through the three input modes.



Press ENTER.



The display will prompt you to enter the Auxiliary Input phone selection. Use the number keys to select the phone numbers to be dialed when the Auxiliary Input is in alarm. You can choose all of the eight numbers that you programmed for dial out, or any combination of the eight numbers. Remember, regardless of what order you enter your Input phone selections, the phone numbers will be dialed in order, according to their sequence number (1-8). The display will reflect this.

Use the number keys.

1 Temp #1	2 Temp #2	3 Temp #3
4 AC Pwr	5 Battery	6 High Water
7 Bilge #1	8 Bilge #2	9 Auxiliary

0  
Security

Number keys on the pressure sensitive keypad

Press ENTER.



The display will reflect your selection.

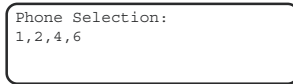

## Security Input

The Security Input is a dry contact detection circuit that monitors the open or closed status of any normally open or normally closed security accessory item, such as a magnetic reed switch. To program the Security Input:

Press SET.





Press SECURITY.



The Local Display will prompt for you to choose normally open or normally closed. The default is normally open. Use the MODE key to toggle between open and closed. When your choice is displayed press ENTER.

Press the MODE key to toggle between open and closed.



Press ENTER.



Using the number keys on the keypad enter the Alarm Recognition Time, hours and minutes. The range is from 1 second to 999 minutes 59 seconds. The default is 1 second.

Use the number keys to enter minutes.

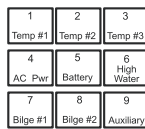

Number keys on the pressure sensitive keypad

Press ENTER.



Repeat for seconds.

The Input Mode will be displayed. The default is Off. Press the MODE key on the keypad until the appropriate mode is shown on the display.

Press the MODE key to toggle between open and closed.



Press ENTER.



The display will prompt you to enter the Security Input phone selection. Use the number keys to select the phone numbers to be dialed when the Security Input is in alarm. You can choose all of the eight numbers that you programmed for dial out, or any combination of the eight numbers. Remember, regardless of what order you enter your Input phone selections, the phone numbers will be dialed in order, according to their sequence number (1-8). The display will reflect this.

Use the number keys.

1 Temp #1	2 Temp #2	3 Temp #3
4 AC Pwr	5 Battery	6 High Water
7 Bilge #1	8 Bilge #2	9 Auxiliary

0  
Security

Number keys on the pressure sensitive keypad

Press ENTER.



The display will reflect your selection.

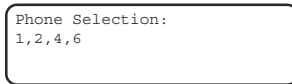

## VERIFYING PROGRAMMING

### The WHAT IS? key

To verify what has been programmed, simply press *WHAT IS?* and then press the key sequence used in programming. The previously programmed information will then be displayed on the Local Display or played back on the speaker, if a Voice Message. To move through the Display Screens use the arrow keys.

For example, to verify the Voice Message of Temperature Input #2:

Press WHAT IS?.

What is?

Press VOICE MESSAGE.

Voice  
Message

Press TEMP #2.

2  
Temp #2

The previously recorded message will be replayed.

*"The outside temperature is 74°F"*

To verify System parameters:

Press WHAT IS?.

What is?

Press SYSTEM.

System  
Code

A screen will appear on the Local Display with all of the System parameters that have been programmed. Use the down arrow to scroll through the menu.

Maximum Calls:  
Call Delay:  
Intercall Dly:  
Dialing Method:



# CHAPTER 4

## OPERATION

**A**fter installation and programming have been completed, Boat Remote is fully operational. This chapter explains the sequence of events that occur during an alarm to illustrate how Boat Remote operates.

Part One outlines the basic alarm sequence. Part Two provides a sample programming strategy and details how Boat Remote responds in common monitoring applications.

### PART ONE: THE ALARM SEQUENCE

There are 3 stages to complete an alarm event: 1) Alarm Recognition, 2) Alarm Notification, 3) Acknowledgment. Note that not all alert conditions will go through each stage. For example, some may not need the recognition time. Others may be acknowledged locally before dial out starts.

#### Alarm Recognition

1. Boat Remote monitors inputs for High Water Level, Security, AC power, Battery Voltage, 3 Temperature inputs, an Auxiliary input, and the activity of 2 Bilge Pumps. When the status of an input changes or exceeds user-programmed limits, it causes an alert condition.
2. If the alert condition lasts long enough to meet its programmed recognition time, the alert condition becomes an alarm and Boat Remote begins the alarm notification sequence.

#### Alarm Notification

The alarm notification sequence depends on Boat Remote's operating mode:

- Standby Mode: Boat Remote does not recognize alert conditions and will not create an alarm.
- On-Board Mode: Boat Remote recites a voice alarm message continuously until a key is pressed and will not dial out.
- Away Mode:

- 1) Boat Remote waits the programmed Call Delay time before

dialing out. During this time (if the speaker is set to ON), the unit will recite an alarm message locally to indicate which input is in alarm. If someone on board acknowledges the alarm before the Call Delay time expires, the unit will not dial out.

2) Boat Remote checks the programmed dial out selection list for the current alarm condition and dials the first number on the list.

## Dial Out

### **Call Progress**

Boat Remote monitors call progress when dialing out. If Boat Remote dials out and encounters a busy signal or no answer, the unit hangs up, waits the programmed intercall delay time, and then dials the next phone number.

Boat Remote can make two types of phone calls, voice or beeper.

### **Voice**

When dialing out to a phone number programmed as 'voice', Boat Remote waits for the phone to be answered, then recites its user-recorded identification message, then recites the alarm message.

Below is an example of what Boat Remote might say during a typical 'voice' dial out:

*"Hello, this is (ID message). The water level is too high"*

*"Hello, this is (ID message). The water level is too high"*

*"Hello, this is (ID message). The water level is too high"*

*"Indicate you have received warning message."*

In this example, the number of Message Repetitions is three.

NOTE: If the call reaches an answering machine, the message will be recorded but Boat Remote will be talking over your outgoing message, so you will probably lose part of the first alarm message repetition.

### **Beeper**

When dialing out to a phone number programmed as 'beeper', Boat Remote can leave a number (usually the unit's own phone number) on the display of a numeric beeper.

## **IMPORTANT**

When dialing out to a phone number programmed as 'beeper', Boat

Remote DOES NOT speak a voice message. It calls the beeper company or service, enters the number to be displayed on the beeper, then hangs up.

## Alarm Acknowledgment

### Local

Alarms can be acknowledged locally by pressing any key on the Boat Remote keypad.

Example: Boat Remote is operating in On-Board Mode. Bilge Pump #1 has exceeded its programmed maximum run time. Boat Remote begins to repeat the message "Bilge Pump 1 ran too long." Since you are on board, you hear the message and acknowledge the alarm locally by pressing any key on the Boat Remote keypad.

### Remote Voice Dial Out

Repeated below is the same example of what Boat Remote might say during a typical 'voice' dial out: (must be in Away Mode)

*"Hello, this is (ID message). The water level is too high"*

*"Hello, this is (ID message). The water level is too high"*

*"Hello, this is (ID message). The water level is too high"*

*"Indicate you have received warning message."*

### '555' Acknowledgment Code

Boat Remote will now wait 5 seconds for the touch-tone acknowledgment code '555', or '999' (see below), to be entered. When you press the '5' key on a touch-tone phone, Boat Remote will echo the word "five" back to you. After the third '5' has been received, Boat Remote will respond by saying, "Alarm Acknowledged". The alarm has been acknowledged and the unit will hang up. Once the alarm has been acknowledged, the dial out process stops.

### '999' Acknowledgment Code

Substituting the '555' acknowledgment code with '999' will acknowledge the alarm and, for the input that is in alarm, will change the Input Mode from Active to Status Only. This is useful if an input is going in and out of alarm.

To remotely change the alarm input's mode follow the directions for the '555' acknowledgment code, but substitute '555' with '999'. The response will be, "Input disabled. Alarm acknowledged. Good-bye."

**NOTE:** You may enter the touch-tone acknowledgment code '555', or '999', at any time during the alarm message.

If the touch-tone acknowledgment code is not received, Boat Remote will respond by saying, "Good-bye," and hang-up.

The alarm has not been acknowledged. Boat Remote will hang up and wait for a callback acknowledgment. This waiting period is called the 'intercall delay time'. During this time you may call the unit back from a touch-tone phone and enter the '555' code to acknowledge the alarm.

**NOTE:** An alarm cannot be acknowledged using a pulse (rotary) telephone.

### **Beeper Dial Out**

Boat Remote will dial out to your beeper service and leave a number on the display of your beeper. (See Programming Chapter for special dialing codes for beepers/pagers). The unit will then hang up without speaking a voice message and wait for a callback acknowledgment. This waiting period is called the 'intercall delay time'. During this time you may call the unit back from a touch tone phone to receive a report of the alarm condition and acknowledge the alarm by entering the '555' acknowledgment code.

Below is an example of what Boat Remote will say when you call it back to acknowledge a typical Bilge Pump alarm:

*"Hello, this is (ID message)"*

*"Bilge pump 1 ran too long"*

*"Hello, this is (ID message)"*

*"Bilge pump 1 ran too long"*

*"Hello, this is (ID message)"*

*"Bilge pump 1 ran too long"*

*"Indicate you have received warning message."*

Boat Remote will now wait for the touch-tone acknowledgment code '555' to be entered. When you press the '5' key on a touch-tone phone, Boat Remote will echo the word "five" back to you. After the third '5' has been received, Boat Remote will respond by saying: "Alarm Acknowledged". The alarm has been acknowledged and the unit will hang up. Once the alarm has been acknowledged, the dial out process stops.

**NOTE:** You may enter the touch-tone acknowledgment code '555' at



any time during the alarm message. If the touch-tone acknowledgment code is not received, Boat Remote will respond by saying, "Good-bye." The alarm has not been acknowledged. Boat Remote will hang up and wait for the rest of the intercall delay time. During this remaining time you may call the unit back again from a touch tone phone and enter the '555' code to acknowledge the alarm.

**TIP:** When Boat Remote is programmed to make calls to beepers, make sure the intercall delay time is long enough to give the person carrying the beeper some time to get to a phone to call the unit back.

### **Automatic Alarm Acknowledgment - (Max Calls)**

Boat Remote has the ability to acknowledge alarms itself by using the Max Calls function. The unit keeps a count of the number of phone calls it makes for a particular alarm. Once the number of calls made reaches Max Calls, Boat Remote will acknowledge the alarm and stop the dial out process.

## **PART TWO: SAMPLE PROGRAMMING STRATEGY**

An example programming strategy is outlined below. Communications and monitoring programming are charted to give you a reference for the examples to follow. Next, possible alarm situations you may encounter in your own application are given to explain how Boat Remote will respond.

This section does not cover all the possible circumstances that you may encounter, but it should give you an understanding of the many features of the Boat Remote.

### **Communications Programming**

- Dial out Phone Numbers:
- Phone #1: 555-1111 (voice) - Marina Office
- Phone #2: 555-2222WP5552628#(beeper) - Marina manager's beeper
- Phone #3: 555-3333 (voice) - your vacation/weekend residence
- Phone #4: 555-4444 (voice) - your primary residence
- Phone #5: 555-5555 (voice) - your car/cellular phone

- Phone #6: 555-6666WPP5552628# (beeper) - your beeper
- Phone #7: (voice) - not programmed
- Phone #8: (voice) - not programmed
- Boat Remote's telephone number: 555-BOAT (555-2628)
- Rings until answer: 5
- Listen-in time: 10 seconds
- Speaker: ON
- TAD: OFF
- Call Delay Time: 30 seconds
- Intercall Delay Time: 2 minutes
- Voice Repetitions: 3

### Monitoring Programming

<u>Input</u>	<u>Alarm Limits</u>	<u>Rec. Time</u>	<u>Mode</u>	<u>Dialout Select.</u>
Temperature #1	hi-105, low-35	10 sec.	Active	3,4,5,6
Temperature #2	hi-100, low-40	3 sec.	Status Only	none
Temperature #3	hi-100, low-40	3 sec.	Status Only	none
AC Power		30 min.	Active	1,2,3,4,5,6
Battery	hi-15.5V, low-10V	5 min.	Active	3,4,5,6
High Water		1 min.	Active	1,2,3,4,5,6
Bilge Pump #1	run time-30 min. cycles/hrs - 5/24		Active	3,4,5,6
Bilge Pump #2	run time-5 min. cycles/hrs-0/0		Off	none
Auxiliary		30 sec.	Active	3,4,5,6
Security		2 sec.	Active	1,2,3,4,5,6

## Examples

Each example is divided into three parts: Alarm Recognition, Alarm Notification, and Acknowledgment. Alarm Recognition refers to the events that occur when a monitored condition changes or exceeds programmed limits. Alarm Notification details how Boat Remote delivers its alarm message and Acknowledgment illustrates how an alarm is acknowledged.

### **EXAMPLE 1 (Away Mode: voice dialout & acknowledgment)**

#### **Alarm Recognition**

Your boat develops a slow leak but the bilge pump does its job and pumps out the excess water. However, the leak causes the pump to cycle more often than normal. One day the pump must cycle 5 times within 24 hours. The bilge pump turns on for the fifth time (programmed bilge pump cycle limit), and the Bilge Pump #1 input is set to "Active" so Boat Remote enters the Alarm Notification sequence.

#### **Alarm Notification**

- 1) Boat Remote waits 30 seconds (the programmed Call Delay time). During this time, the unit recites the message "Bilge Pump #1 cycle rate exceeded. 5 cycles in the last 24 hours." (Speaker: ON)
- 2) The unit is operating in Away Mode, so after 30 seconds it checks the dialout selection list for the Bilge Pump #1 input. Since this is not an emergency situation, you've programmed Boat Remote to contact you directly in the event of a bilge pump alarm rather than call the marina. The unit dials the first number on the list (phone #3, your vacation/weekend residence, 555-3333).
- 3) Nobody is home and the call is answered by an answering machine.
- 4) Boat Remote recites the following message 3 times (programmed number of voice repetitions)

*"Hello, this is (Boat Remote ID Message).*

*"Bilge Pump #1 cycle rate exceeded. 5 cycles in the last 24 hours."*

NOTE: Boat Remote will speak its alarm message during the answering machine's outgoing message, so part of the first alarm message repetition will not be recorded.

- 5) After the third repetition, the unit will request acknowledgment:

*"Indicate you have received warning message."*

6) The answering machine can't enter the acknowledgment code, so after 10 seconds Boat Remote will say:

*"Error."*

7) The unit hangs up.

8) Boat Remote waits 2 minutes (programmed Intercall Delay time) then dials the next number on the dialout selection list (phone #4, your primary residence, 555-4444).

9) The call is answered.

10) Boat Remote recites the following message 3 times (programmed number of voice repetitions)

*"Hello, this is (Boat Remote ID Message).*

*"Bilge Pump #1 cycle rate exceeded. 5 cycles in the last 24 hours."*

11) After the third repetition, the unit will request acknowledgment:

*"Indicate you have received warning message."*

### **Acknowledgment**

1) You enter the '555' acknowledgment code. The unit then says:

*"Alarm acknowledged"*

2) The unit will then hang up. The alarm has been acknowledged and the dialout sequence stopped.

NOTE: Boat Remote will not dial out again for a Bilge Pump #1 alarm unless the input returns to its normal state and then is tripped again.

### **EXAMPLE 2 (Away Mode: voice dialout & acknowledgment)**

#### **Alarm Recognition**

Your boat's slow leak has suddenly become a serious leak and the bilge pumps can't keep up with the incoming flow of water. The rising water trips a float switch wired to the High Water input of your Boat Remote. The float switch remains closed for 1 minute (the programmed alarm recognition time) and the High Water input is set to "Active" so Boat Remote enters the Alarm Notification sequence.

#### **Alarm Notification**

1) Boat Remote waits 30 seconds (the programmed Call Delay

time). During this time, the unit recites the message

*"The water level is too high". (Speaker: ON)*

2) The unit is operating in Away Mode, so after 30 seconds it checks the dialout selection list for the High Water input. It then dials the first number on the list (phone #1, Marina office, 555-1111).

3) The call is answered.

4) Boat Remote recites the following message 3 times (programmed number of voice repetitions)

*"Hello, this is (Boat Remote ID Message).*

*The water level is too high."*

5) After the third repetition, the unit will request acknowledgment:

*"Indicate you have received warning message."*

### **Acknowledgment**

1) The Marina office has been instructed on what to do if they get a call from your Boat Remote so they enter the '555' acknowledgment code. The unit then says:

*"Alarm acknowledged"*

3) The unit will then hang up. The alarm has been acknowledged and the dialout sequence stopped.

NOTE: Boat Remote will not dial out again for a High Water alarm unless the float switch returns to its normal state and then is tripped again.

### **EXAMPLE 3 (Away Mode: beeper dialout & acknowledgment)**

#### **Alarm Recognition**

Late one night an electrical overload causes a circuit breaker to trip inside the junction box providing dockside AC Power to your boat. The power stays off for of 30 minutes (the programmed alarm recognition time) and the AC Power input is set to "Active" so Boat Remote enters the Alarm Notification sequence.

#### **Alarm Notification**

1) Boat Remote waits 30 seconds (the programmed Call Delay time). During this time, the unit recites the message

*"The AC power is off".*

- 2) The unit is operating in Away Mode, so after 30 seconds it checks the dialout selection list for the AC Power input. It then dials the first number on the list (phone #1, Marina office, 555-1111).
- 3) The Marina office is closed at night so the unit receives no answer and hangs up.
- 4) Boat Remote waits 2 minutes (programmed Intercall Delay time) then dials the Marina manager's beeper (phone #2).
- 5) The phone is answered.
- 6) The unit leaves its telephone number (555-2628) on the beeper display.
- 7) The manager's beeper goes off and he calls the displayed number.

### **Acknowledgment**

- 1) After 5 rings, Boat Remote answers the incoming call and says:

*"Hello, this is (Boat Remote ID Message).*

*The AC Power is off.*

*Indicate you have received warning message."*

- 2) The Marina manager enters the '555' acknowledgment code and Boat Remote says:

*"Alarm acknowledged"*

- 3) The unit will then hang up. The alarm has been acknowledged and the dialout sequence stopped.

NOTE: Boat Remote will not dial out again for an AC Power failure unless the power is restored and then fails a second time.

### **EXAMPLE 4: (On-Board Mode: local acknowledgment)**

#### **Alarm Recognition**

While you have your boat out for a cruise, an electrical system problem develops and your boat's batteries slowly begin to discharge. The battery voltage drops below the programmed low limit of 10.0 volts. The condition continues for 5 minutes (the programmed alarm recognition time) and the Battery input is set to "Active" so Boat Remote enters the Alarm Notification sequence.

#### **Alarm Notification**

- 1) Boat Remote repeats the message "The battery voltage is low"

until the alarm is acknowledged. Since Boat Remote is in On-Board Mode, an alarm dial out will not occur. The red warning LED will continue to blink and the alarm condition will continue to be displayed on the LCD screen.

### **Acknowledgment**

1) The unit is operating in On-Board mode, so you must acknowledge the alarm by pressing any key on the Boat Remote keypad. The unit will beep and the red LED will change from blinking red to steady red if the alarm condition still exists. If the alarm condition has been corrected, the red LED will go from blinking red to off.

## **STATUS REPORT**

The status report function allows you to call in to Boat Remote and check the status of all monitored conditions. The unit will answer an incoming call after the programmed number of rings until answer. If any alarm conditions exist, the alarm message will be recited. For information on an input to be included in the status report, that input's mode must be set to either "active" or "status-only".

The following is an example of what Boat Remote will recite during a status report if all inputs are activated.

*"Hello,*

*This is the King Crimson docked at the Big Fish Marina, slip number 21. (recorded ID message)*

*or: This is Boat Remote. (default ID message)*

*Bilge Pump 1 cycled 4 times today for a total of 7 minutes 46 seconds.*

*Bilge Pump 2 cycled 3 times today for a total of 6 minutes 23 seconds.*

*The battery voltage is 13.7 volts. (current battery voltage)*

*The AC power is ON. (Other response: OFF)*

*The cabin temperature (recorded message for Temp #1 input) is 65.4 degrees Fahrenheit/Celsius.*

*or Temperature #1 (default voice message for Temp #1 input) is 65.4 degrees Fahrenheit/Celsius.*

*Engine room temperature (recorded message for Temp #2 input) is*

*59.5 degrees Fahrenheit/Celsius.*

*or Temperature #2(default voice message for Temp #2 input) is 59.5 degrees Fahrenheit/Celsius.*

*The ocean water temperature (recorded message for Temp #3 input) is 55.8 degrees Fahrenheit/Celsius.*

*or Temperature #3(default voice message for Temp #3 input) is 55.8 degrees Fahrenheit/Celsius.*

*The water level is OK. (Other response: TOO HIGH)*

*Engine room door (recorded message for auxiliary input) is OK. (Other response: IN ALARM)*

*or: Auxiliary (default voice message for auxiliary input) is OK*

*Security channel is OK. (Other response: SECURITY ALARM)*

*Listen to the sound level for 15 seconds. (User-programmed listen-in time)*

*Have a good day."*



## CHAPTER 5: TROUBLESHOOTING

In the event that a problem is encountered, this section will assist you in determining the cause so you can return the unit to its usual monitoring routine with minimal interruption.

Most problems with the Boat Remote are easy to identify and quickly corrected, and are found under the following general headings:

- \* Communications/Dial Out functions
- \* Temperature monitoring
- \* Bilge Pump monitoring
- \* Other monitoring functions

If you have tried the solutions outlined in this section and are not satisfied with the results, call Customer Service, (610)558-2700, or follow the guidelines for shipping the Boat Remote to Phonetics for repair. (See the Repair Appendix)

### COMMUNICATIONS DIAL OUT

**PROBLEM: The Boat Remote fails to detect an alarm condition.**

**CAUSE:** The Boat Remote is operating in STANDBY MODE.

**SOLUTION:** Press the MODE button and change to either AWAY MODE or ON-BOARD MODE.

**CAUSE:** The input is turned OFF or is programmed for STATUS-ONLY.

**SOLUTION:** Reprogram the input so that it is ACTIVE.

**CAUSE:** Alarm recognition time is too long. A fault condition does not remain in effect long enough to become a valid alarm.

**SOLUTION:** Reprogram the recognition time for the monitored condition to a shorter duration or trip the alarm for a longer period of time.

**CAUSE:** There are no phone numbers programmed.

**SOLUTION:** Program phone numbers.

**CAUSE:** The call selection list for the monitored input is empty.

SOLUTION: Program some numbers in the call selection list.

CAUSE: Broken wires, touching wires or a faulty sensor.

SOLUTION: Inspect the wiring and test the sensor operation with a continuity tester or ohmmeter.

**PROBLEM: The Boat Remote fails to dial out.**

CAUSE: The telephone line is not connected or is not turned on.

SOLUTION: Verify that the telephone line is good by checking it with a telephone, then make sure the Boat Remote is connected.

CAUSE: The telephone number may be incorrectly programmed.

SOLUTION: Recheck the telephone number programming.

CAUSE: The current dialing method (Tone or Pulse) is not compatible with the telephone line on which the Boat Remote is installed.

SOLUTION: Change the dialing method in the SYSTEM menu.

CAUSE: The call delay is set too long.

SOLUTION: Reprogram the call delay in the SYSTEM menu so that the time is shorter.

CAUSE: Max Calls is set to zero.

SOLUTION: Reprogram Max Calls to a number greater than zero. It is a good idea to set your Max Calls to at least equal the number of telephone numbers programmed.

CAUSE: The Boat Remote is connected to an incompatible telephone line.

SOLUTION: The Boat Remote must be connected to a standard (2-wire analog) telephone line, not a digital extension to a phone system. If the unit will not dial out and the factors listed previously have been ruled out, try connecting the unit to a standard residential telephone line.

CAUSE: An alarm is not being detected.

SOLUTION: See previous troubleshooting section.

**PROBLEM: The Boat Remote will not answer when called for a status report or alarm acknowledgment.**

CAUSE: Rings Until Answer is programmed to high.

SOLUTION: Recheck programming for Rings Until Answer in the

SYSTEM menu and adjust if necessary.

**CAUSE:** The Boat Remote is connected to an incompatible telephone line.

**SOLUTION:** Some telephone systems will not allow the telephone to ring beyond 4 rings. If your Boat Remote's Rings Until Answer is set at more than 4 rings you may not be able to access the unit. Try setting the Rings Until Answer to less than 4 rings. If this does not correct the problem, it may indicate telephone line incompatibility. In this case, try connecting the Boat Remote to a standard residential telephone line.

**PROBLEM: The Boat Remote and another telephone answering device (sharing the line) answer incoming calls simultaneously.**

**CAUSE:** The Boat Remote's number of Rings Until Answer is set to the same number of rings for the other device.

**SOLUTION:** Change the number of Rings Until Answer for the Boat Remote to a number greater than the rings for the other device. Also, make sure the TAD (Telephone Answering Device) option is set to ON in the SYSTEM menu.

**PROBLEM: The Boat Remote recites the alarm message over the telephone, but is silent at the installation site.**

**CAUSE:** The speaker is turned off.

**SOLUTION:** Turn the speaker on by changing the speaker on/off parameter in the SYSTEM menu.

## **TEMPERATURE MONITORING**

**PROBLEM: The temperature reading is -20.1°F or -29.1°C.**

**CAUSE:** The temperature sensor has been disconnected or has a broken wire.

**SOLUTION:** Examine the wires to the temperature sensor and connect or replace the wiring.

**PROBLEM: The temperature reading is 160.1°F or 72.1°C.**

**CAUSE:** The temperature sensor wires are touching.

**SOLUTION:** Verify and correct wiring.

**PROBLEM: The temperature reading is inaccurate.**

**CAUSE:** An incompatible temperature sensor is attached to the Boat Remote.

SOLUTION: Replace the temperature sensor with a 10K sensor from Phonetics or an approved alternate source.

## **OTHER MONITORING**

**PROBLEM: The alarm status of the security or auxiliary input is incorrect.**

CAUSE: The input normality, open/closed, is incorrect.

SOLUTION: Reprogram the input normality for the appropriate input.

**PROBLEM: False power failure alarms.**

CAUSE: The programmed recognition time is too short.

SOLUTION: AC power is often subject to brief interruptions. To avoid frequent, false alarms, increase the power recognition time.

**PROBLEM: The Boat Remote does not recognize power failure.**

CAUSE: The power input is not programmed for the active mode.

SOLUTION: Reprogram the power input to be ACTIVE.

CAUSE: The power has not been off long enough to meet the recognition time.

SOLUTION: Reprogram the power recognition time.

CAUSE: The Boat Remote is not connected to the 12V boat battery.

SOLUTION: Connect the boat battery to the 12VDC input, refer to Installation Chapter.

**PROBLEM: The bilge pump input does not count on/off cycles.**

CAUSE: The bilge pump input is in OFF mode.

SOLUTION: Reprogram the bilge pump input for ACTIVE mode.

CAUSE: The bilge pump is not wired properly to the Boat remote.

SOLUTION: Double check the wiring to the bilge pump or float switch, refer to the wiring diagrams in the Installation Chapter.

**PROBLEM: The Boat Remote does not turn on when you plug in the power supply.**

CAUSE: The ON/OFF switch below the access panel is turned OFF.

SOLUTION: Remove the bottom access panel and turn the switch ON.

CAUSE: Blown fuse.

**SOLUTION:** Replace the AC power fuse, see Fig 2.2 in Chapter 2. The fuse is rated at 1.5 Amps and is size 2AG.

**PROBLEM: The Boat Remote does not recognize any alarm.**

**CAUSE:** The Boat Remote is in standby mode.

**SOLUTION:** Press the MODE button to change to ON-BOARD or AWAY MODE.

**PROBLEM: The LCD display says that the 3V lithium battery is low.**

**CAUSE:** The internal battery that backs up the voice messages is low.

**SOLUTION:** Replace the battery while the unit is on to preserve the voice messages. The battery is a Tadiran TL-5276/W. Contact Phonetics or your local electronics supplier for a replacement.

If the solutions offered above do not appear to correct the problem, apply the following steps in the order shown.

- \* Remove the lower access panel.
- \* Move the power switch to the OFF position.
- \* Wait one minute for the Boat Remote to completely power down.
- \* Move the power switch to the ON position.

If the Boat Remote appears to have corrupted programming information, you may reset the unit to the factory default settings by entering the following key sequence: 092793.



# **COMMAND SUMMARY**

## **TEMP#1, #2, & #3**

High Limit: +160 deg F max.

Low Limit: -20 deg F min.

Mode: Active, Off, Status-Only

Rec Time: 0m, 0s - 999m, 59s

Phone Selection: 1-8

## **BATTERY**

High Limit: 16V max.

Low Limit: 0V min.

Mode: Active, Off, Status-Only

Rec Time: 0m, 0s - 999m, 59s

Phone Selection: 1-8

## **SYSTEM**

Max Calls: 1-255

Call Delay: 0m, 0s - 999m, 59s

Intercall Delay: 0m, 30s - 999m, 59s

Dialing Method: Pulse/ Tone

TAD: On/Off

Voice Reps: 1 - 10

Rings til Answer: 1 - 255

Listen-In: 0 - 255s

Speaker: On/Off

Temp Scale: deg F/deg C

Output Trigger: All, Security-Only

Output Mode: Away, Away/Onboard

Current Time: xx:xx (military)

Today's Date: month/day

## **AC POWER**

Mode: Active, Off, Status-Only

Rec Time: 0m, 0s - 999m, 59s

Phone Selection: 1-8

## **HIGH WATER**

Mode: Active, Off Status-Only

Rec Time: 0m, 0s - 999m, 59s

Phone Selection: 1 - 8

## **BILGE #1 & #2**

Mode: Active, Off, Status-Only

Run Time: (0=disabled), 999m, 59s

Cyc/Hr: (0=disabled), 1-120cyc/1-24hrs

Phone Selection: 1 - 8

Data Reset: Y/N

## **AUXILIARY**

Mode: Active, Off, Status-Only

Rec Time: 0m, 0s - 999m, 59s

Normality: Open/Closed

Phone Selection: 1-8

## **SECURITY**

Mode: Active, Off, Status-Only

Rec Time: 0m, 0s - 999m, 59s

Normality: Open/ Closed

Phone Selection: 1 -8

## MODE Key

- 1) Toggles between Standby, Onboard & Away modes.
- 2) Toggles between parameter options from within a menu.

## ENTER Key

Used to enter programming changes or to clear parameters.

## DOWN ARROW Key

- 1) Scrolls through the idle status screens.
- 2) Used to move through menu options without changing programming parameters.

## ARROW UP Key

- 1) Scrolls through the idle status screens.
- 2) Used as a backspace key when entering phone number or dialout selection.

## CODE Key

- 1) Used to insert a decimal point.
- 2) Used to program special dialing options within a phone number.

CODE 1 = W, wait til answer

CODE 2 = P, pause for 2 seconds

CODE 3 = V, give voice report and hangup

CODE 4 = #, hangup the call

CODE 5 = D, wait for dial tone



## **APPENDIX B:**

### ***Checking Your Boat Remote for Proper Operation***

We recommend that you test your Boat Remote weekly to be sure it is functioning properly. This will ensure that when a problem arises the Boat Remote will be ready to alert the appropriate personnel.

There are several tests that can be performed:

- 1) Call the unit and listen to the Status Report. This will test the unit's ability to answer the phone and speak a message. It will also verify that all of the inputs are reading properly, the alarm conditions are OK, the electricity is on, the microphone is functioning, and that the battery voltage is OK.
- 2) Create an alarm on each input and allow the unit to contact all programmed telephone numbers. This will ensure that the Boat Remote is programmed properly. It will also prepare personnel to respond appropriately when they receive a call from the Boat Remote.
- 3) Test the battery backup system by unplugging the AC adapter and making sure that the Boat Remote continues to function. Press WHAT IS then STATUS on the keypad, and listen to the status report. Make sure the report states that "the AC power is off" and that the battery voltage is at an acceptable level. Keep the AC adapter unplugged so that a Power Failure alarm occurs. Allow the unit to dial all programmed telephone numbers while running on battery backup. Plug in the AC adapter after the unit has finished dialing all of the telephone numbers.



# **APPENDIX C:**

## **ENGINEERING SPECIFICATIONS**

### **I. General**

The Automatic dialer shall be a self-contained microprocessor controlled system capable of monitoring 10 alarm channels. The system shall be configured for operation by the user by means of the built-in keypad. The system shall have one alarm output. Characteristics of Input and Output channels include Dry Contact Input, 12V Run Time Input, 0-16V Analog Input, 10K Thermistor Input and 12VDC Output.

Upon detection of any alarm or status change, the system shall commence dialing telephone numbers from a list associated with the particular alarm condition(s). The alarm message shall be delivered in digitized human voice using messages recorded by the user. The system will continue to call telephone numbers in succession until a positive acknowledgment of the alarm message is received. Acknowledgment is accomplished by depressing tone keys from the called telephone, or by calling the system back within a programmed time period. The alarm may also be acknowledged by using the local keypad. In addition, the system shall be able to receive incoming telephone calls. Upon answering, the system shall recite a status report.

The system shall be FCC registered for direct connection to the telephone network. The system shall have a one year warranty from the manufacturer. The system shall be a Boat Remote by Phonetics, Inc.

### **II. I/O Channel Attributes and Features**

#### **A. Inputs**

The system shall come standard with (2) Bilge Pump Inputs, (1) High Water Input, (3) Temperature Inputs, (1) Security Input, (1) Auxiliary Input and (1) 12V Battery Input.

The system shall have the following built-in monitoring features:

1. AC Power failure detection
2. Temperature with pre-wired 10K thermistor (-20F to 160F)

All monitored channels, including built-in monitoring features, shall

allow local keypad programming of pertinent operational data including, but not limited to:

1. High and Low Limits (temperature, battery voltage)
2. Maximum continuous run-time (Bilge pumps)
3. Maximum cycle rate (Bilge pumps)
4. Alarm recognition time
5. Operating mode: Active, Status-only, Off
6. Input Type (NO/NC)
7. Telephone call list

**B. Output**

The system shall have one built-in 12V output. The output may be programmed to switch when any alarm occurs or only when a security alarm occurs. The 12V power is derived from the boat battery input and is fused at 3A.

**III. Communications Features**

**A. Telephone Specifications**

The system shall connect to a standard two-wire telephone line using pulse or tone, with loop start only. The system shall recognize ringer frequencies from 16 to 60Hz. No leased or dedicated lines shall be required. The system shall also be capable of being used on the same line as other answering devices. Call progress detection shall ensure that the alarm dial out is not hindered by no answers or busy signals.

**B. Telephone Numbers**

The system shall be capable of dialing up to 8 telephone numbers, 32 digits each. The system shall allow local keypad programming of the following telephone dialing information.

1. Dialing method (pulse or tone)
2. Message repetitions (1-10)
3. Maximum number of calls (0-255)
4. Call delay time (0-999min 59sec)
5. Intercall Delay time (30sec-999min 59sec)
6. Telephone Answering Device Compatibility

### C. Voice Messages

The system shall have the ability to record, store and reproduce voice messages to articulate the location and status of the monitored channels. In absence of user-recorded messages, the system shall articulate channel status using the internally resident vocabulary. All digitized speech message data shall be stored in nonvolatile memory with a 3V lithium battery backup. Such battery backup shall be capable of protecting speech memory for at least 5 years of complete power outage.

There shall be one recorded identification message for the system, a recorded message for each temperature input and 1 recorded message for the auxiliary input. Message length shall be 5 seconds per input channel and 10 seconds for the identification message.

### D. Beeper/Pager Dial out

The system shall be capable of intelligently dialing out to a numeric beeper or pager. The dialing sequence shall be programmable such that the pager number is dialed, the system waits for the telephone to be answered, and then additional identification Touch Tones™ are transmitted.

## **IV. Programming**

### A. Local Programming

The system shall contain an integral, sealed keypad for the purpose of locally programming all system data. All programming parameters as well as system status information shall be displayed on the LCD.

## **V. Remote Operational Features**

### A. Status Report

The system shall allow the user to call into the unit at any time using any standard telephone to obtain a full status report of all monitored channels including present temperature and listening-in to on-site sounds. The status report shall be articulated using the resident digitized vocabulary in combination with user-recorded voice messages.

### B. Acknowledgment

An alarm on any monitored channel may be acknowledged remotely by pressing tones on a Touch Tone™ telephone keypad. An alarm may also be acknowledged locally using the built-in keypad.

## **VI. Enclosure, Environmental and Power**

### **A. Enclosure**

The system shall be housed in a black ABS plastic enclosure with keyholes on the back for wall mounting. Field wiring shall enter the enclosure through a slot in the back or may also enter through a knockout on the bottom end of the enclosure. Terminal strips for field wiring are located beneath the slide panel, which can be removed by loosening two screws on the bottom end panel.

### **B. Power**

The system shall be provided with a U.L. listed 12VAC power transformer that the user will plug into a 117VAC wall outlet, +/-20%, 60Hz. The power consumption from this source shall be 6.2 Watts. The system shall also connect to the 12VDC boat battery system for secondary power as well as battery voltage monitoring. The power consumption from this secondary source shall be 1.6 Watts if the primary power is not present, otherwise the power drawn from the secondary source is 0 Watts.

### **C. Local Visual Indication**

Two LED indicators shall be provided to indicate operating mode and alarm status. The system shall also have an LCD display that will list information about the current system status and input/output status.

### **D. Electrical Protection**

Power and telephone connections shall have internal spike and surge protection using metal oxide varistors and solid state transient suppressors. Three replaceable fuses shall be provided to protect the AC power supply (1.5A), boat battery (1.5A), and output signal (3.0A). The fuses shall be size 2AG.

### **E. Additional Electrical Surge Protection**

Additional power and telephone line surge protection shall be available from the manufacturer. When so installed, the system shall be fully warranted against any damage caused by transient surges entering the system through power or telephone lines.

### **F. Environmental**

The system shall function over an operating range of -10°C - 50°C (14°F - 122°F) at up to 0-90%RH, non-condensing.

G. Maintenance

The system manufacturer shall have in-house service facilities and technical assistance available during normal business hours (EST).

*Specifications subject to change without notice.  
Copyright 1995 Phonetics, Inc. Marine Division.  
Touch Tone™ is a registered trade mark of AT&T.*

***Phonetics, Inc.***

Marine Division  
901 Tryens Road  
Aston, PA 19014

Phone: (610)558-2700 FAX: (610)558-0222





## **APPENDIX D:**

### **RETURNING YOUR UNIT FOR REPAIR**

In the event that the Boat Remote does not function properly, we suggest that you do the following:

1. Record your observations regarding the Boat Remote's malfunction.
2. We recommend that you call the Customer Service Department at (610) 558-2700, prior to sending the unit to Phonetics for repair.

If the unit must be sent to Phonetics for servicing, please do the following:

1. Unplug the AC power supply from the wall outlet and disconnect all sensors from the alarm inputs.
2. Carefully pack the unit to avoid damage in transit. Use the original container (if available) or a sturdy shipping box.
3. You must include the following information to avoid processing delays:
  - a) Your name, address, and telephone number.
  - b) A concise note explaining the problem.
4. Ship your package to the address below:

SERVICE DEPARTMENT  
PHONETICS, INC.  
901 TRYENS ROAD  
ASTON, PA 19014
5. Ship prepaid and insured via UPS or US Mail to ensure a traceable shipment with recourse for damage or replacement.



## Free Manuals Download Website

<http://myh66.com>

<http://usermanuals.us>

<http://www.somanuals.com>

<http://www.4manuals.cc>

<http://www.manual-lib.com>

<http://www.404manual.com>

<http://www.luxmanual.com>

<http://aubethermostatmanual.com>

Golf course search by state

<http://golfingnear.com>

Email search by domain

<http://emailbydomain.com>

Auto manuals search

<http://auto.somanuals.com>

TV manuals search

<http://tv.somanuals.com>