



PNR 14-150

OPERATION MANUAL

15" Single Surface Thickness Planer

IMPORTANT:
before operating,
the tool user must
read and under-
stand this manual.

Record your Model and Serial numbers below.
These are located on the tool housing.

Model #

Serial #

Design and specifications are for reference only
and are subject to change without notice.

PIONEER
SUPPLY INTERNATIONAL INC.
HAND TOOLS | MACHINERY | ACCESSORIES



TABLE OF CONTENTS

CONTACT INFORMATION	3
SECTION 1: SAFETY	
General Power Tool Safety Instructions	4-6
Additional Safety for Planers	7
Specification Sheet.....	8
Parts Identification.....	9
SECTION 2: POWER REQUIREMENTS	10
SECTION 3: SET UP	
Set Up	10
Contents	11
Cleaning	12
Site Considerations	12
Moving & Placing Base Unit	12
Extension Wings.....	12
Hand Wheel.....	13
Dust Hood	13
Safety Switch.....	14
Gearbox Oil Level.....	14
SECTION 4: OPERATIONS / ADJUSTMENTS	
Before You Begin	15
Basic Operation	15
Operation Tips	16
Operating Feed Speed	16
Adjusting Height / Depth of Cut	17
Adjusting Bed Rollers	17
Adjusting Alignment on Pulley	18
Adjusting V-Belt Tension.....	18
Anti-Kickback Fingers.....	18
Inspecting Knives	19
Setting/Replacing Knives	19
Feed Rollers and Chip Breaker Adjustments	20
Feed Roller Spring Tension	21
Table Parallelism	22

COPYRIGHT ©January 2006 Pioneer Supply International, Inc. This manual may not be reproduced in any shape or form without the written approval from Pioneer Supply International, Inc.

TABLE OF CONTENTS

SECTION 5: MAINTENANCE

Maintenance Schedule	23
Cleaning	23
Lubrication	23
PARTS BREAKDOWN & LISTING	24-27
WARRANTY AND RETURNS	28-30
Notes	31

Contact Information

PIONEER

SUPPLY INTERNATIONAL INC.

HAND TOOLS | MACHINERY | ACCESSORIES

Pioneer Supply International, Inc.
P.O. Box 12308 | Salem, OR | 97309 | USA

COPYRIGHT ©January 2006 Pioneer Supply International, Inc. This manual may not be reproduced in any shape or form without the written approval from Pioneer Supply International, Inc.

Thank you, for your Pioneer tool purchase. When properly assembled, wired, operated and maintained. Your Pioneer product will give you years of dependable service. Please read and understand the owner's manual completely.

⚠WARNING

Failure to read and understand this manual before you unpack, assemble, wire, operate and maintain this machine may result in serious injury to yourself or others. Review and understand all safety procedures and requirements. If you do not understand any content of this manual including how to assemble, wire, operate and maintain this machine safely, **do not use this machine.**

⚠WARNING

Using power tools or equipment of any kind can be dangerous if safe operating procedures are not followed. Recognizing the hazards of each tool and using them with respect and caution will considerably limit the possibility of personal injury. However, if safety precautions are ignored, personal injury will likely result. Always use common sense your personal safety is your responsibility.

⚠CAUTION

No manual can list every safety precaution or operating procedure as it pertains to a given work area and environment. Use good judgment, think and apply safety before taking any action. Failure to do so may result in serious injury, damage to equipment and surroundings and/or give negative performance results.

NOTICE

We make every effort to be accurate with our pricing, specifications, copy, images and other product information and apologize for any errors that may occur. This information while deemed accurate is not guaranteed. We reserve the right to make changes to all products including specifications, pricing and availability.

⚠ WARNING

Power Tool Safety Instructions

- 1. Read the entire manual before use.**
Power tools and stationary machinery can cause injury or death if not properly used. Learn the tool's application as well as the hazards of setting up and operating this tool.
- 2. Guards;** make sure all guards are in place and working correctly before operating any machinery.
- 3. Do not make** any changes or modifications to any power tool or machinery. This may cause personal injury and even death.
- 4. Maintain machinery** in top working condition. This includes keeping tools clean and sharp. A well cared for machine will be inherently safer and provide longer service and give optimum results.
- 5. Replace damaged parts,** thoroughly inspect machinery before each use, any loose, broken or misaligned parts that need to be fixed before operation. Disconnect machine from power source before inspecting or repairing.
- 6. Accessories,** use only recommended accessories with machinery, home made jigs, fixtures and clamps may be dangerous and cause serious injury.
- 7. Hands and Feet** should be kept away from cutters, moving parts and assemblies at all times.
- 8. Do not over-reach.** Keep proper footing and balance at all times.
- 9. Do not over-exert yourself.** Tools can be heavy. Get assistance to lift and position tools and machinery. Improper lifting and moving beyond your capabilities may cause serious injury.
- 10. Do not operate** equipment while tired or under the influence of drugs, alcohol or medication that causes physical or mental impairment. Full physical and mental alertness is required to operate power tools.
- 11. Always wear eye protection.** Wear only ANSI approved safety glasses. Standard eyeglasses will **not** protect eyes from flying debris.
- 12. Always Use** appropriate hearing protection and respirator while using any power tool.
- 13. Airborne Dust;** Some dust created by power tool and machinery use is known to cause cancer, birth defects or other reproductive harm. To minimize your risk work in a well ventilated area and always wear personal protective equipment such as dust masks and respirators designed to filter out microscopic particles. Lead from lead based paint, crystalline silica from bricks and cement, and arsenic chromium from chemically treated lumber are just some examples.
- 14. Clothing;** No loose clothing, rings, neckties, jewelry, bracelets, and gloves should be worn. These items and others may get caught in equipment and cause serious injury. Non-slip footwear is recommended along with protective hair covering for longer hair.
- 15. Long hair** should be tied back in a way that it does not get caught in machinery.
- 16. Work area;** work in a well lit area, do not operate in dark, damp or wet locations or where any noxious or flammable fumes may be present.
- 17. Operators;** Keep children, visitors and untrained operators away from equipment while in use. Do not get distracted by others when operating power tools.

⚠ WARNING

Power Tool Safety Instructions

18. **Childproof the power tool.** Use lock-out switches on machinery or use master switches or remove starter keys so machines cannot be turned on by children. Make sure power tools cannot be started accidentally.
19. **Never** leave machine running unattended. Disconnect machine from power source when not in use or when performing any maintenance. Don't leave tool until it has come to a complete stop.
20. **Secure work;** Use proper hold downs, clamps, and vises to secure work before machining. It will give you safer control of the work piece and better results.
21. **Use the right tool** for the job. Do not force a tool to do something it was not designed for.
22. **Do not force tool.** Use the tool properly for what it was designed for.
23. **Extension cords;** Do not use undersized extension cords. Use only properly sized & approved grounded extension cords. Do not use extension cords on 220V machinery. Use chart as a reference for minimum gage extension cords. Run only one machine per extension cord. Replace worn or damaged extension cords.
24. **Ground all tools.** Make sure all tools and machinery are properly grounded. Never cut grounding pin from a 3-prong plug.
25. **Accidental Starting;** Make sure switch is in the "OFF" position before plugging in power cord.

⚠ DANGER

26. **Magnetic switches** or starter switches may start unintentionally if accidentally bumped. Disconnect machine from power source when changing blades (tooling), making adjustments or servicing the machine.
27. **Wrenches & chuck keys;** Remove any wrenches, chuck keys or other accessories from the machine before operating.
28. **Do not use** power tool as a bench, stool, ladder or support. Do not stand on the tool.
29. **Kickback;** be aware of "kickback" and how to avoid it. Binding, misalignment, improper settings and adjustment of machinery especially woodworking tools may cause kick-back.

Additional Safety for Planers

INSTRUCTION MANUAL: Be aware of correct operation and potential safety hazards. Read and understand this entire manual before starting the planer.

INFEEED CLEARANCE: The infeed roller is always spinning while machine is in operation. Keep hands, clothing, and long hair away from the infeed area to prevent anything from being pulled into the planer and prevent serious injury.

BODY POSITION: There is a chance that the material or work piece may kick back toward you during operation. Always stand to the side of the planer during the entire operation. NEVER place your face close to planer to look inside while planer is running.

PLANING MATERIAL: Thickness planers are designed to plane natural solid wood stock. Trying to plane MDF, plywood, laminates, or other synthetic or man-made products may damage machine or cause injury.

GRAIN: Always plane in the same direction or at a slight angle with the wood grain. Planing across the grain is hard on the planer and may cause the work piece to kick back.

CLEAN STOCK: Always inspect and clean stock of nails, staples, or loose knots or other debris. This debris can kick back at the operator and will damage your knives when they contact the cutter head.

CUTTING CAPACITIES: Do not push the planer beyond its listed capacities. Material kick back may result and injury to operator or damage to machine may result:

- Maximum Depth of Cut 1/8"
- Minimum Board Length 12"
- Minimum Board Thickness 1/4"
- Maximum # of Boards at One Time 1

PLANER COVERS: Never remove guards or covers while operating planer. Wood chips fly around inside the planer at a very high rate of speed and could cause seriously injury.

JAMMED WORK PIECES:  **WARNING:** Always stop the planer and disconnect power before removing jams. Never attempt to remove jammed work pieces and never reach into dust hood to remove clogs when the planer is running serious injury may result.

DULL/DAMAGED KNIVES: Dull or damaged knives will not only give poor finish results but may kick back, that can cause personal injury.

CHANGING KNIVES: Disconnect machine from power source.  **CAUTION:** Planer knives are sharp, handle them with care.

MAKING ADJUSTMENTS:  **WARNING:** Magnetic switches may start when bumped. Make sure planer is disconnected from power source before performing any service or maintenance to the machine. Failure to do so may cause serious personal injury.

PLANER USE:  **WARNING:** Do not use this planer for other than its intended use. Failure to do so could result in serious personal injury, damage to equipment, or poor work results.



SPECIFICATION SHEET

PNR 14-150 15" Single Surface Thickness Planer

Item Number	PNR 14-150
Description	15" Single Surface Thickness Planer
Motor HP	3hp, 220v, 1ph, 18A
Table size	15" x 19-7/8"
Footprint (less extensions)	23" x 21"
Overall width	26-5/16"
Height	47-1/4"
Knives	3 HSS
Cutter head speed	5000rpm
Cutter head diameter	2-7/8"
Maximum cutting depth	1/8"
Maximum planing width	14-7/8"
Maximum planing height	6"
Cuts per minute	15,000cpm
Feed rate - 2 speeds	16fpm & 20fpm
Maximum cuts per inch	62
Minimum stock height	1/4"
Minimum stock length	8"
Appx Net Weight	500lbs
Approx Shipping Weight	560lbs

FEATURES:

- Extra-large hand wheel
- Spring loaded cutter head for easy knife setting
- Two chromed return rollers
- Three roller extension wing
- Two positive table locks
- One-piece cabinet style stand
- Infeed rollers: Spiral-serrated
- Outfeed rollers: Machined
- Power transfer: Triple belt drive
- Two adjustable bed rollers
- Scratch resistant powder-coated paint

INCLUDES:

- Knife setting gauge
- Infeed/outfeed extensions
- Top return rollers
- 4" dust port
- Magnetic switch w/thermal overload

NOTE: We make every effort to be accurate with our specifications, copy, images and other product information and apologize for any errors that may occur. This information while deemed accurate is not guaranteed. We reserve the right to make changes to all products including specifications, pricing and availability.

PIONEER SUPPLY INTERNATIONAL, INC.
P.O. Box 12308
SALEM, OR 97309

Parts Identification - PNR 14-150

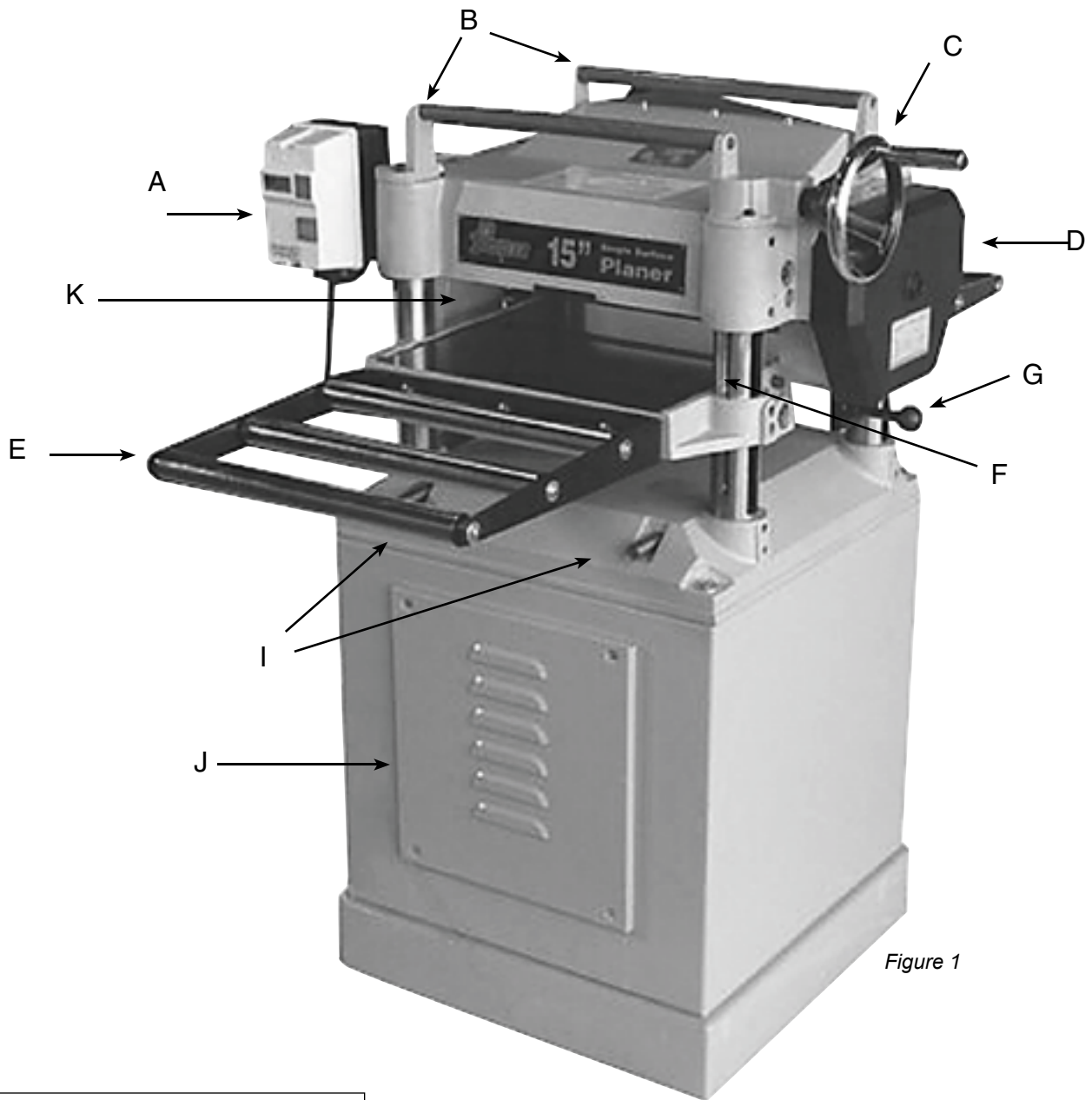

Figure 1

- A Magnetic Switch
- B Return Rollers
- C Table Height Hand wheel
- D Gearbox
- E Extension Wing
- F Table Height Scale
- G Speed Control Knob
- H Table Locks - Figure 2
- I Lifting Bars
- J Motor Access Cover
- K V-Belt Cover

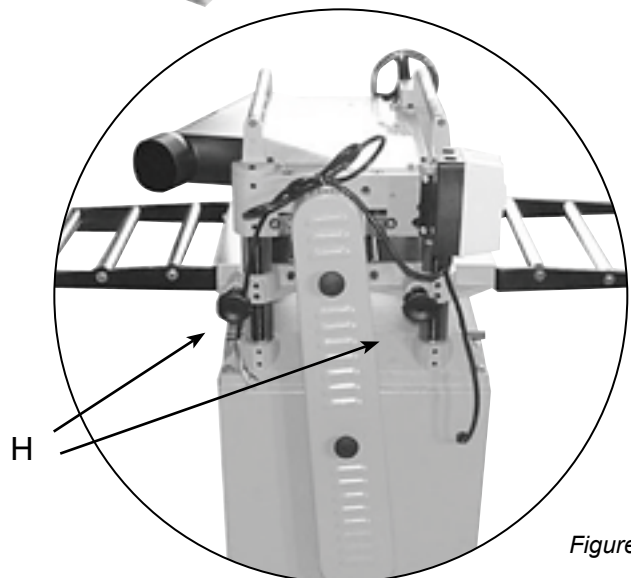

Figure 2

SECTION 2: Power Requirements



WARNING: Machine must be grounded properly to prevent electrocution or fire. Ensure your electrical configuration complies with local and state codes. Contact qualified electrician to ensure compliance. DO NOT connect the machine to the power source until instructed to do so, as serious personal injury could occur.

220V Single-Phase Grounding

All electrical connections must be made in accordance with local codes. Grounding reduces the risk of electric shock if an electrical short happens. This machine has a power cord that has a grounding wire, which must be properly connected to the grounding prong on the plug. NOTE: The outlet must be properly installed and grounded for this to operate properly.

Amperage Draw / Minimum Circuit Requirements

The motor on the PNR 14-150 will draw 18 amps during operation. Only connect your machine to a circuit that meets the requirements. Always check to see if the wires and circuit breaker in your circuit are capable of handling the amperage draw from your machine, as well as any other machines that could be operating on the same circuit. If you are unsure, consult a qualified electrician. NOTE: Start up amperage draw is significantly higher than running draw.

Plug Type / Extension Cords

An L6-20 plug and receptacle is recommended to connect your machine to power. It is NOT recommend using extension cords on 220V equipment. Instead, arrange the placement of your equipment and the installed wiring to eliminate the need for extension cords. If you find it absolutely necessary to use an extension cord at 220V with your machine, check with a qualified electrician for the correct sizing, gauge, type, and maximum possible length for your needs.

SECTION 3: Set up



WARNING: This planer is a heavy machine (560 lbs. shipping weight). DO NOT over-exert yourself while unpacking or moving this machine. To be safe, you will need assistance and power equipment when moving the shipping crate and removing the machine from the crate. Safety glasses should be worn during the entire set up process. Read through this entire manual to become familiar with the set up, controls and operations before starting the machine.

The Pioneer PNR 14-150 was carefully packed when it left the warehouse. If you discover the machine is damaged after you have signed for delivery, please call your supplier immediately. Save the containers and all packing materials for possible inspection by the carrier or its agent. Photograph any damage. Otherwise, filing a freight claim can be difficult. When you are completely satisfied with the condition of your shipment, you should inventory the contents before beginning set up process.

In the event that any nonproprietary parts are missing (e.g. a nut or a washer), contact your supplier, or for the sake of expediency, replacements can be obtained at your local hardware store.

The following items are needed to complete the set up process, but are not included with your machine: 4' straightedge or longer, dial indicator, phillips screwdriver, flat head screwdriver, plug and receptacle.

Contents - PNR 14-150

- A Planer
- B Extension Wings
- C Dust Hood
- D Dust Hood Hardware
- E Hand Wheel
- F Hand Wheel Hardware
- G Knife Setting Guide Shaft
- H Open End Wrenches:
8-10, 12-14, 17-19mm
- I Allen Wrenches: 3,4,5,6mm
- J Set Screws for Extension Wings (6)
- K Bolts for Extension Wings (6)
- M Washers (6)



A



B



C

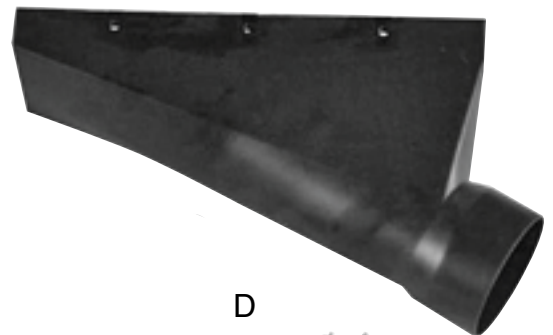

D



E



F



G



H



I



J



K



L



Figure 3

Cleaning

The unpainted surfaces are coated with a waxy oil to protect them from corrosion during shipment. Remove this protective coating with a solvent cleaner or citrus-based degreaser to clean thoroughly, some parts may need to be removed. For optimum performance from your machine, make sure you clean all moving parts or sliding contact surfaces that are coated. Avoid chlorine-based solvents, such as acetone or brake parts cleaner, as they may damage painted surfaces should they come in contact. Always follow the manufacturer's instructions when using any type of cleaning product. **These items are coated and must be cleaned:** Cutter head, Table, Feed Rollers, and Extension Wings.



WARNING: Gasoline and petroleum products have low flash points and could cause an explosion or fire if used to clean machinery. DO NOT use gasoline or petroleum products to clean the machinery. Many of the solvents commonly used to clean machinery can be toxic when inhaled or ingested. Lack of ventilation while using these solvents could cause serious personal health risks or fire. Take precautions from this hazard by only using cleaning solvents in a well ventilated area.

Site Considerations



WARNING: DO NOT allow unsupervised children or visitors in shop at any time.

Floor Load

The PNR 14-150 has a shipping weight of 560 lbs (254Kg), net weight of 500 lbs (226.8Kg), and a base footprint of 32" x48".

Working Space

In order to have a safe working environment, there should be enough space around the machine to walk around the machine and enough room to plane material both at the infeed and outfeed sides without bumping into other people, machines and obstructions. See Figure 4.

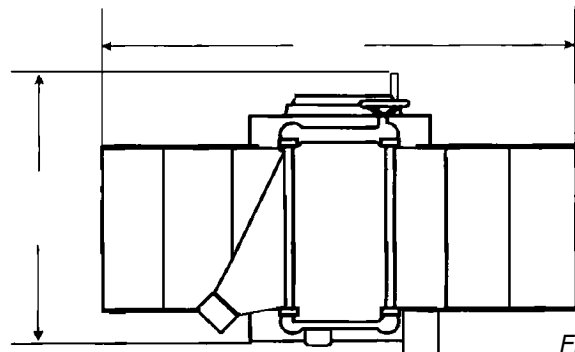

Figure 4

Moving & Placing Planer

The cabinet stand on the PNR 14-150 is equipped with lifting bars (Refer to page 9) to lift and place the planer. When lifting the planer with a forklift, place shop rags or cardboard between the forks and cabinet base so you do not scratch the paint.

Extension Wings

You will need:

Two Table Extension Wings, 6 x Hex Bolts, 6 x Lock Washers, 6 x Flat Washers. 4 x Set Screws.

To attach the table extension wings:

- 1 Install set screws in the holes in the side of the wings (see Figure 5).
- 2 Attach the table extension wings to the planer table with the hex bolts, lock washers, and flat washers, as shown in Figure 6, but do not fully tighten the



Figure 5

- Using a straightedge as a guide and the set screws for leveling control, position the extension wings even with the table, then fully tighten the hex bolts.

NOTE: Be aware that the bed rollers will give you a false reading with your straightedge if they are raised above the table. Move them down or work around them when leveling the extension wings.

Hand Wheel

You will need:

Hand wheel, Hand wheel Bushing, Hand wheel Handle, Hex Nut, Flat Washer

To install the Hand wheel:

- Place the bushing on the Hand wheel shaft.
- Insert the key into the shaft keyway.
- Screw the handle into the Hand wheel.
- Place the Hand wheel on the shaft and secure it with the hex nut and flat washer, as shown in Figure 7.

Dust Hood



IMPORTANT: If you are not using a dust collection system, do not use plastic dust hood to direct chips. We recommend to always use a dust collector when operating this planer.

You will need:

Dust Hood, 3 x Hex Bolts, 3 x Cap Screws, 6 x Flat Washers, 3 x Hex Nuts, 6 x Flange Bolts

To install the dust hood:

- Attach the dust hood to the top of the planer with the hex bolts, flat washers, and hex nuts as shown in Figure 8. **NOTE:** You will need to reach into the dust hood to get access for fastening the nuts.
- Attach the bottom of the dust hood to the planer with the cap screws.
- If you have a dust collector, attach it to the dust hood now. **NOTE:** To maximize work results and minimize clogging, chip out, etc., use a dust collector with your planer.



Figure 6

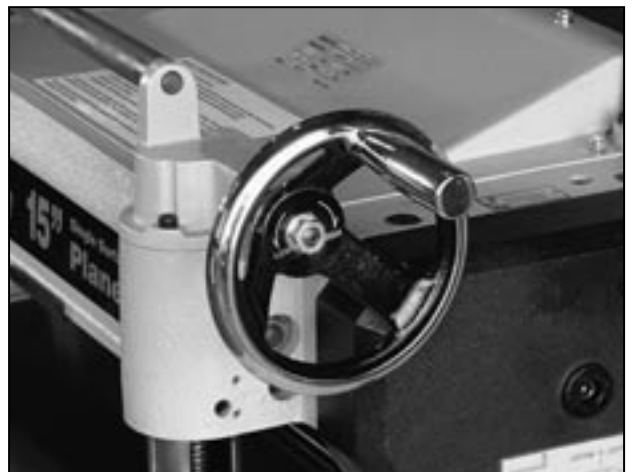

Figure 7



Figure 8

Safety Switch

NOTE: The magnetic switch is there for your safety and should not be replaced by a standard power switch. If the power goes out, the magnetic switch prevents the machine from starting when the power is returned, and protects the operator from an accidental start and possible injury.



Figure 9

Gearbox Oil Level



WARNING: Before starting your machine for the first time, make sure the gearbox has oil. The proper oil level is just even with the bottom of the fill plug hole. The gearbox uses 80W-90W gear oil.

To check the gearbox oil level:

- 1 Remove the gearbox fill plug (Figure 11).
- 2 Using the short end of the hex wrench, dip it inside the fill hole and remove it. If the end of the hex wrench is coated with oil, then the gearbox oil level is okay.
- 3 Replace the fill plug and skip to the next section. If the end of the hex wrench is not coated with oil, then you need to add more oil. Refer to maintenance section of this manual for instructions on how add or drain oil.

NOTE: Replace the gearbox oil after the first 20 hours of operation. This is a normal break-in procedure.



Figure 10

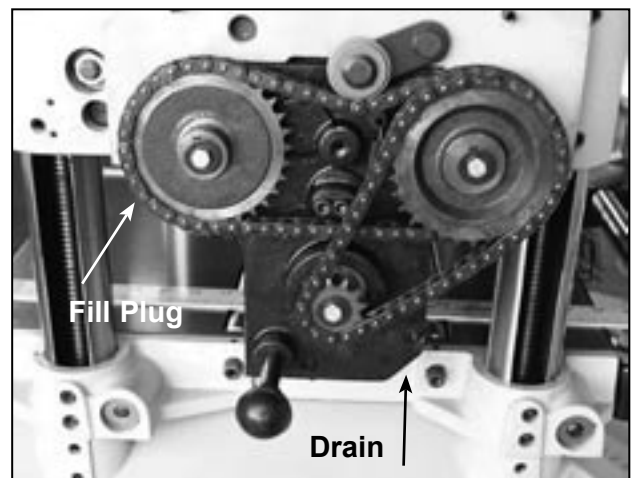

Figure 11

SECTION 4: Operations / Adjustments

Your Pioneer thickness planer has been fully adjusted at the factory and no further setup is required to operate your machine. However, because of handling and transit, some of these adjustments may need to be repeated to ensure optimum cutting results. Keep this in mind as you start to use your new planer.

❗ IMPORTANT: If you have never used a planer before, it is strongly recommended that you become confident of your personal understanding of how this machine operates and how it is adjusted.

Before You Begin

- 1 Read the entire instruction manual, and make sure oil is in the gearbox.
- 2 Make sure all tools and foreign objects have been removed from the machine.
- 3 Put on safety glasses, and secure loose clothes or long hair.
- 4 Connect your planer to the power source.
- 5 Press the on button on the Magnetic switch.

The planer should run smoothly with little or no vibration.

- After if you suspect any problems, immediately stop the planer by pushing the red button.
- Disconnect planer from power source before performing any trouble shooting or maintenance.
- If you need any help with your planer call your supplier.

Basic Operations



WARNING: Loose hair and clothing could get caught in machinery and cause serious personal injury. Keep loose clothing rolled up and long hair tied up and away from machinery. Damage to your eyes, lungs, and ears could result from using this machine without proper protective gear. Always wear safety glasses, a respirator, and hearing protection when operating this machine.

NOTE: The table moves approximately 1/16" (1.59mm) with one turn of the Hand wheel.

The basic steps of operating the planer are as follows:

- 1 Always wear safety glasses, hearing protectors and respirator.
- 2 Unless your work piece is very flat, surface plane the work piece on a jointer until it is flat—having the face flat will ensure that it sits flat on the planer table during operation.
- 3 Start the planer.
- 4 Adjust the table height to slightly lower than your work piece height to ensure the first cut is as light as possible (approximately 1/32" to 1/16" or .8mm to 1.59mm).
- 5 Place the flat side of the board down on the table, and feed the work piece through the planer, making sure not to stand directly in front or behind the work piece to avoid kickback injury. **NOTE:** If the cut is too heavy and bogs down the planer, turn the planer off immediately, allow it to come to a complete stop, remove the work piece, and repeat Steps 4 & 5.
- 6 Measure your work piece thickness and adjust the table height as necessary to take a lighter or heavier pass, depending on your needs. For most wood types, 1/16" (1.59mm) per pass is a good cutting depth.

NOTE: Any time you switch directions, either up or down, with the hand wheel, there will be a small amount of play. This will be slightly less than 1/16" (1.59mm). However, as long as you move the hand wheel in the same direction during operation, this will not be a factor.

Operation Tips

- ✓ Lumber should be clean and dry. Inspect for defects like loose knots, warping, cupping, twisting, glue and for foreign objects (nails, staples, imbedded gravel, etc.). If you have any question about the quality of your lumber, do not use it. Wood with more than 20% moisture content or wood exposed to rain or snow, will plane poorly and leave a feathery surface. Wet wood causes excessive wear to the knives and motor and can also hasten rust and corrosion.
- ✓ In order to create even wear on the blades, alternate between the left, the right, and the middle when feeding lumber into the planer. Your knives will remain sharp much longer and you won't get worn spots on the blades.
- ✓ Plane ONLY natural wood fiber. No wood composites such as plywood, chipboard etc.
- ✓ Plane with the grain. Never feed end-cut or end-grained lumber into your planer.
- ✓ Avoid boards with loose knots, splits, cross grain or other obvious blemishes or defects. They can damage the blades and pose the possibility of operator injury.
- ✓ Keep your work area clear and clean.
- ✓ Use the stock return rollers to move material from the outfeed area back to the infeed area when working on long stock.

Operating Feed Speed

The infeed and outfeed rollers move the stock through the planer while keeping boards flat and providing a consistent rate of feed and pressure. Use the different feed rates as stated below:

Low Feed RateDimensioning Pass
High Feed Rate Finishing Pass

The planer has three positions for the feed rate knob as seen in Figure 13. The knob position closest to the machine produces the high feed speed (20 FPM); moving away from the machine produces the low speed (16 FPM) and moving the knob to the center position places the gearbox in neutral.



WARNING: Only change the speeds when the planer is running, but DO NOT attempt to change speeds during any cutting operations or damage to the gearbox will result.



Figure 12

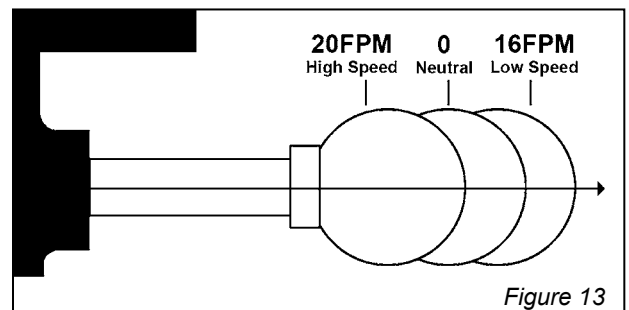

Figure 13

Adjusting Height / Depth of Cut

- 1 Turn handwheel clockwise or counter-clockwise to adjust to the required height of table. (Figure 14)
- 2 Before adjusting height, the lock knobs must be loosened. When required height is obtained, tighten the lock knobs. (Figure 15-A)
- 3 The scale displaying the height increments is located on right front column. (Figure 16)

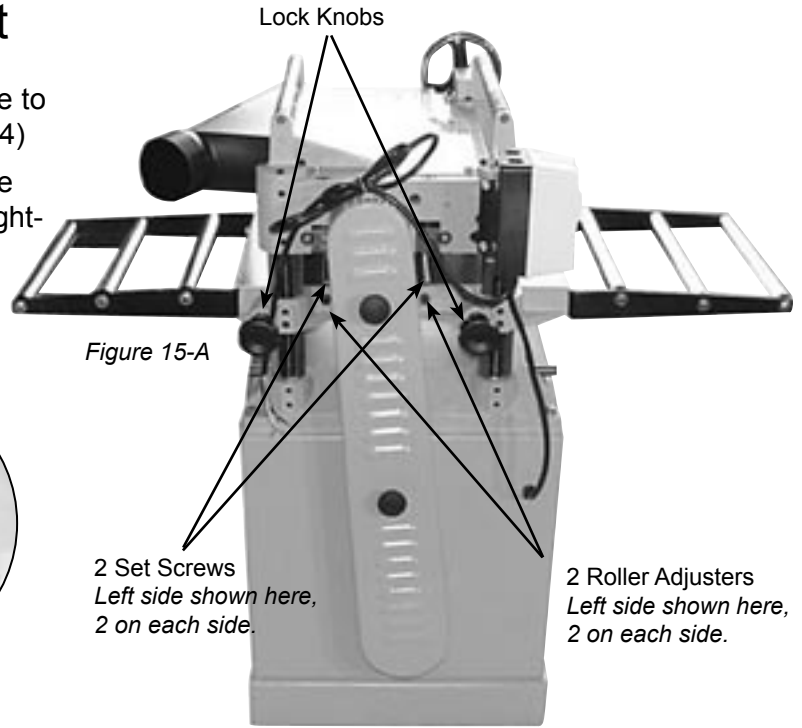

Figure 15-A



Figure 14

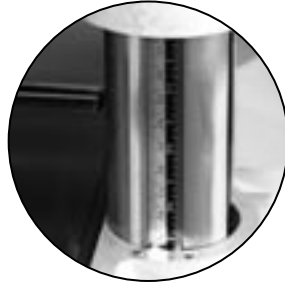

Figure 16

Adjusting Bed Rollers

You can adjust the height of the bed rollers according to the material being planed. As a general rule keep the roller height within 0.002"– 0.020" (.050 –.5mm) above the table (Figure 17). When planing rough stock, set the rollers high to keep the lumber from dragging along the bed. When planing milled lumber, set the rollers low to help minimize snipe.

Misaligned bed rollers can be the root of many planing problems, so care must be taken to achieve precise results side to side along the roller length. To ensure accurate results and make the adjustment process quicker and easier, a dial indicator is recommended. However; if not available, a straightedge and feeler gauges can be used.

Adjusting the bed rollers:

- 1 Ensure machine is switch off and unplugged from power source.
- 2 Lower the table to it's maximum opening to give yourself working room below the cutter head.
- 3 Loosen the 4 set screws (Figure 15-A & 15-B) above the roller adjusters.
- 4 Rotate the adjusters to raise or lower the rollers to reach your desired height.
- 5 Verify both sides of the bed roller are at the same height, and lock them in position with the set screws.
- 6 Double check the roller heights to make sure they did not change when you locked them (if they changed, repeat the procedure). Height must be equal.

Figure 15-B

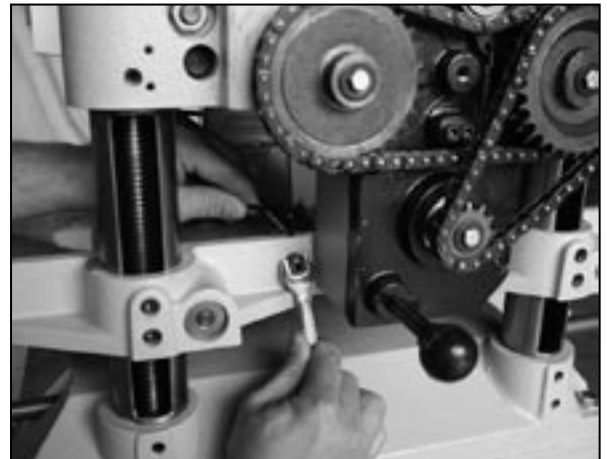

One Set Screw & Roller Adjuster - Right side shown here.

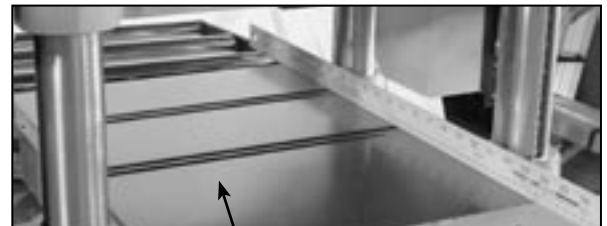
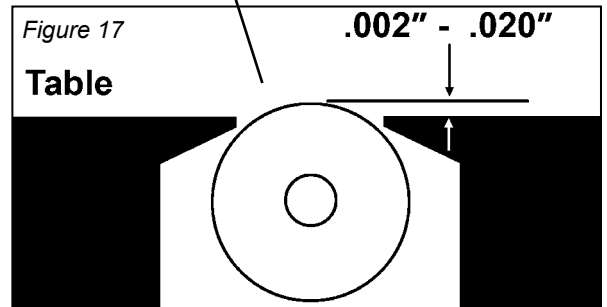

Figure 17

Table

.002" - .020"



Adjusting Alignment on Pulley

Using a straightedge, check to see if the motor pulley is in line with the shaft pulley (Figure 18). If they are not in line, loosen screws as shown in figure 19-A. Move motor to left and right until adjusted to proper position and then tighten screw again.

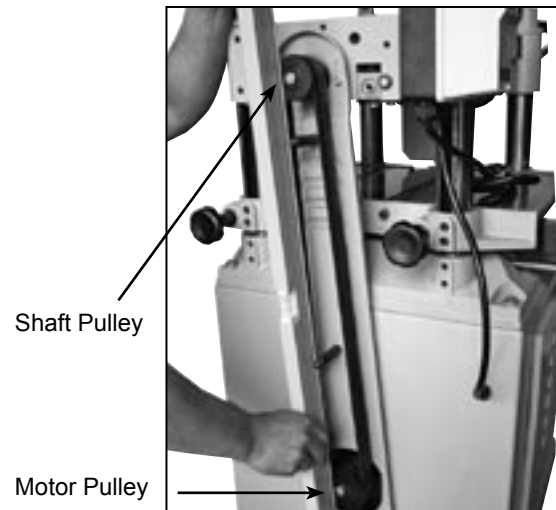
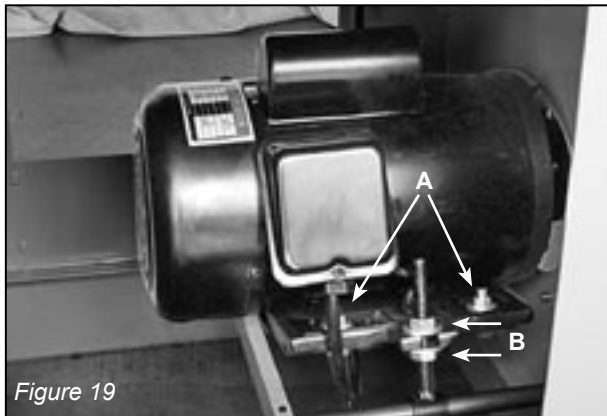

Adjusting V-Belt Tension

This must be done after approximately 16 hours of operation. During this first 16 hours the V-belts will stretch and seat into the pulley grooves. After this 16 hours, the V-belts must be tensioned or V-belt life will be severely reduced.

NOTE: Pulleys and belts run warm. This is a normal condition. Allow them to cool before making adjustments. Some black dust at the bottom of the belt housing is normal during the life of the V-belt.

The correct tension for the V-belts is 1/4" deflection when pushing the center with moderate pressure. Adjust/replace belts by using the motor mount bolts (Figure 19-B) to control the tension. **NOTE:** Always change belts as a matched set when replacing. If only one or two is replaced, the belt tension may not be even, causing premature belt failure and possible injury.

Anti-Kickback Fingers

NOTE: Proper operation of the anti-kickback fingers is essential for the safe operation of this machine and to prevent serious operator injury.

The anti-kickback fingers hang from a rod suspended across the cutter head casting and should be inspected regularly. Check the fingers (Figure 21) to ensure that they swing freely and easily. If the fingers do not swing freely and easily, blow or brush out the saw dust, and clean them with a wood resin solvent. Do not apply oil or other lubricants, which would attract dust and dirt.



Figure 21

Inspecting Knives

The planer knives are preset at the factory to surface medium to hard density wood when cutting 1/16" to 1/8" depths depending upon the width of the stock. Planer knives need to be periodically inspected for nicks and wear. Planer knives should be set approximately .070" above the cutterhead. To inspect and remove the knives for sharpening follow the steps below.

To inspect the knives:

- 1 Disconnect the planer from the power source.
- 2 Remove the cover and dust chute. (Figure 22)
- 3 **CAUTION!** Planer knives are sharp be careful.
- 4 Inspect the knives for nicks and excessive wear and sharpen or replace if necessary.
- 5 To inspect the knives for proper height, place the knife gauge (Figure 23) over the cutterhead with the legs resting flush to the cutterhead. The knives should lightly contact the middle tab of the knife gauge and should not rock. Check all 3 knives left and right sides. (Fig 24)
- 6 If knives need adjusting or to be replaced follow the setting and replacing knives procedures.

Setting/Replacing Knives

NOTE: It is crucial to safety and planning results that the knives are sharp and correctly set. If one knife protrudes higher than the others, it will do the majority of the work, and produce poor results.

To set or replace the knives:

- 1 Disconnect the planer from the power source.
- 2 Remove the top cover and dust chute.
- 3 Remove the belt guard to expose the cutter head pulley.
- 4 Rotate the cutter head pulley to give you good access to one of the knives.
- 5 Loosen the cutter head gib bolts slightly, starting at one end moving across to the other side alternating back and forth until they are all loose.

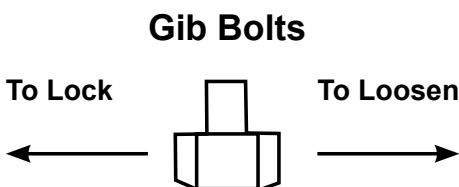

Figure 22



Figure 23

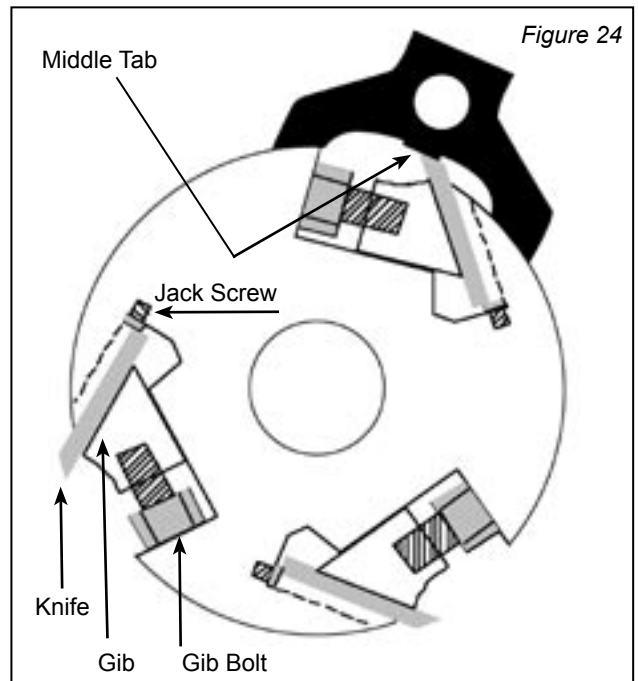

Figure 24

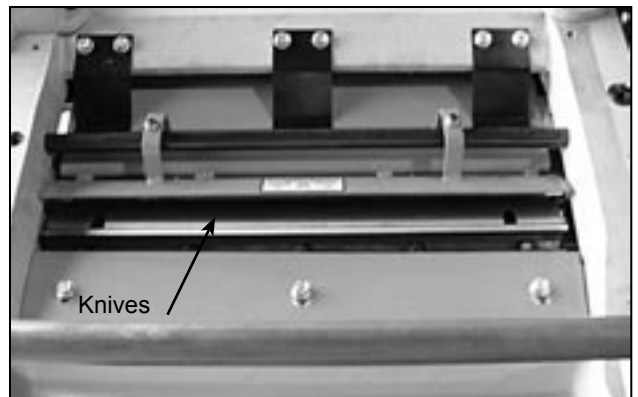

Figure 25

- 6 Position the knife gauge over the knife as shown in Figure 24 and loosen the gib bolts until the knife is completely loose.
- 7 Jack Screws - Using a 3mm hex wrench, rotate the jack screws to raise or lower the knife. When the knife is set correctly, it should barely touch the middle pad of the knife setting gauge. Snug the gib bolts tight enough to just hold the knife in place. Repeat Steps 5-7 with the rest of the knives.
- 8 Rotate the cutter head to the first knife you started with. Slightly tighten all the gib bolts, starting at the ends and working across the cutterhead. Repeat this step on the rest of the knives.

❗ **IMPORTANT:** Sometimes the knives start to "walk" during the final tightening sequence (lift off the jack screws). Make sure the knives stay in position until final tightening is achieved.

Feed Rollers and Chip Breaker Adjustments

The infeed, outfeed rollers and chip breaker are preset at the factory for normal use. If material is not feeding evenly through the planer follow these adjustment procedures.

For adjusting the infeed, outfeed rollers and chip breaker (Figure 26) you'll need to cut 2 parallel boards (zeroing boards) as shown in figure 28 and follow steps 1 through 7.

❗ **IMPORTANT:** Make sure the boards are exactly the same width and thick enough not to tip sideways. Joint and rip a 2 x 4 to size. (3-1/2"W x 1-1/2"H x 32"L)

Zeroing the Planer

- 1 Disconnect planer from the power source.
- 2 Remove the top cover and dust hood of the planer.
- 3 You will need to remove the belt cover so you can rock the cutterhead back and forth. ⚠ **WARNING:** Do not move the cutterhead by touching it directly, injury may result.
- 4 Lower the bed rollers so they are below the bed surface. Bed rollers are shown in figure 27.
- 5 Place the 2 boards parallel to each other as shown in fig 28.
- 6 Crank the table up to the point where the bottom of the cutterhead is almost touching the boards.
- 7 By holding onto the pulley, rock the cutterhead back and forth and slowly crank the table up until the bottom arc of the planer knife just "kisses" the top of the board. Once this happens lock the planer bed in position. You will notice the chip breaker and feed rollers are pushed up to the same level as the lowest arc of the planer knife.



Outfeed Roller Chip Deflector Infeed Roller Figure 26

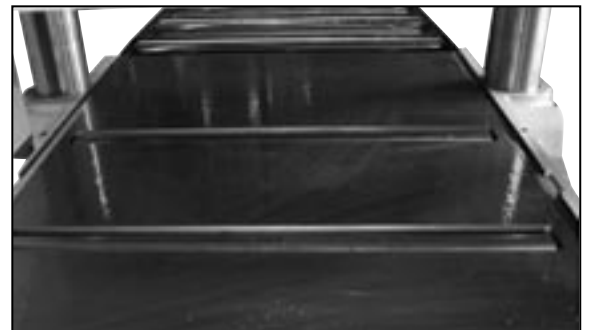

Figure 27



Figure 28

Feed Rollers

- 1 Follow steps 1-7 above.
- 2 Remove the gear box cover to access to the adjusting screws.
- 3 To function properly the infeed roller needs to extend below the lowest arc of the cutterhead approximately .030".
- 4 To adjust; loosen the jamb nut and using a 3mm Allen wrench and a feeler gauge tighten or loosen until there is .030" space between the Allen screw and infeed block. Lock the setting by tightening the jam nut. Set both left and right hand sides. See figure 29.
- 5 Adjust the outfeed roller using the same procedure as in step 4 and set the space between the set screw and blocks to .020" on both the left and right hand sides. Lock the settings by tightening the jam nuts.
- 6 Remove the zeroing boards and replace the pulley cover, top hood, dust chute and gear box cover. Make sure all adjustments are correct and all fasteners are secure before starting the planer.

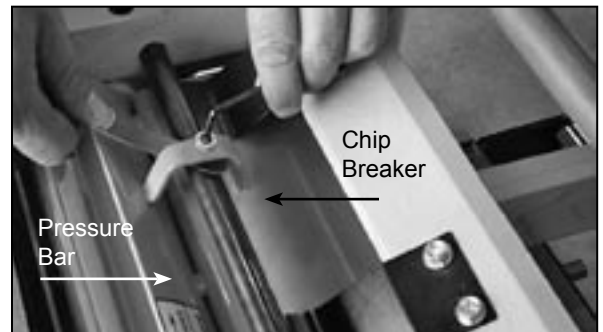

Figure 29

Chip Breaker

For adjusting the chip breaker, use the same procedures for zeroing the planer as in steps 1 through 7 above.

- 1 Make sure planer is disconnected from power source.
- 2 To function properly the chip breaker needs to extend below the lowest arc of the cutterhead approximately .040". It's purpose is to snap the chips off the board and direct them away from the cutterhead. There is no pressure bar on this planer.
- 3 To adjust; loosen the jamb nut and using a 3mm Allen wrench and a feeler gauge tighten or loosen until there is .035" space between the Allen screw and bar. Lock the settings by tightening the jam nuts. Set both left and right hand sides. See figure 30.
- 4 Remove the zeroing boards and replace the pulley cover, top hood and dust chute. Make sure all adjustments are correct and all fasteners are secure before starting the planer.



Adjustment Area

Figure 30

Feed Roller Spring Tension

The infeed and out feed rollers are under spring tension so material can be feed evenly through the planer. When stock feed is erratic or stops completely, roller pressure adjustment may be needed. Proper roller height adjustment must be completed before adjusting roller tension. Refer to feed roller adjustment. Also the bed rollers need to be properly adjusted. Refer to bed roller adjustment section.

The 4 adjustment screws, 2 for the infeed and 2 for the outfeed rollers are located on the top of the head casting. See figure 31

- 1 Make sure the planer is disconnected from power source.
- 2 Start by turning the adjusting screws flush to the casting. Tighten as needed. The rougher the material the more tension you need on the rollers. Do not over tighten.
- 3 Adjust all screws to the same depth. Once this is completed adjust the outfeed roller to have slightly more tension than the infeed roller.
- 4 Lumber should feed smoothly and evenly through the planer.



Figure 31

Table Parallelism

Your Pioneer planer is pre-set parallel at the factory and should rarely need adjustment. However, in the instance that lumber is not parallel in width follow the adjustment procedures.

Table Parallelism Inspection

- 1 Disconnect from power source before performing any adjustments.
- 2 Table parallelism adjustments less than .016" (the difference in thickness from one side of the board to the other)
- 3 Loosen the caps screws that hold the head casting in position. (Figure 32) Move the casting up or down to the proper position and tighten. See figure 33 and 34. Plane another test piece.

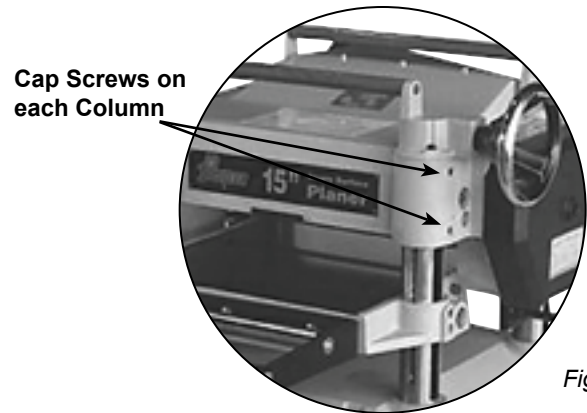
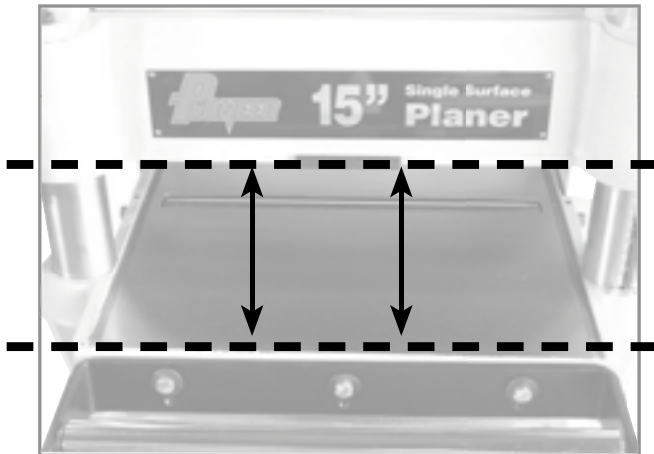
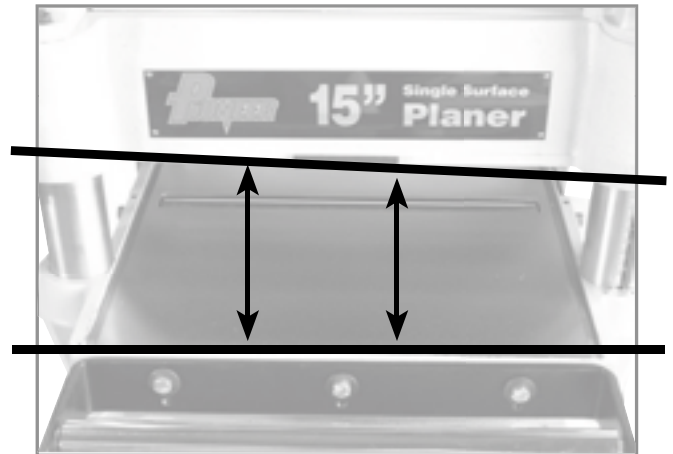

Figure 32



Correct Parallel

Figure 33



Not Correct Parallel

Figure 34

Adjusting Table Parallelism

If the variance is greater than .016" you will need to turn the column sprockets to adjust parallelism.

- 1 You first need to gain access to the sprockets by tilting the planer on its side. **▲ WARNING:** The planer is very heavy and should not be tilted by one person or by hand. Use proper lifting methods.
- 2 Loosen the 2 bolts that hold the idler sprocket which places tension on the chain. (Figure 35)
- 3 Remove the chain from the sprocket that needs to be adjusted.
- 4 Turn this sprocket by hand either left or right depending on which way the adjustment is needed. Adjust this sprocket to be the same as the other 3. One tooth will usually be enough to make the adjustment.
- 5 Turning the sprocket clockwise will reduce the distance between the head casting and the table and turning the sprocket counter-clockwise will increase this distance.

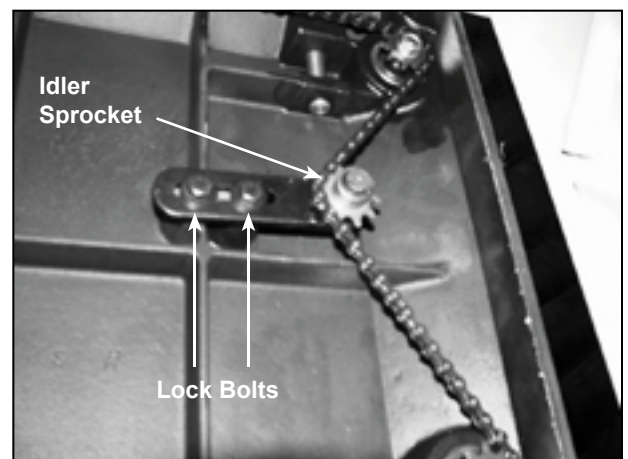

Figure 35

SECTION 5: Maintenance



WARNING:

Always disconnect power to the machine before performing any maintenance. Failure to do this may result in serious personal injury.

Maintenance Schedule for Optimum Performance	
NOTE: This schedule is for machines that are under daily use. Adjust accordingly for your level of use.	
DAILY	Keep unpainted cast iron parts of table clean.
	Lubricate feed rollers.
WEEKLY	Clean cutter head of all debris.
	Lubricate all four columns.
MONTHLY	Inspect V-belt tension, damage, and wear. NOTE: Should be done after first 16 hours of use.
	Clean out the dust buildup from inside cabinet and off motor.
	Lubricate worm gear.
YEARLY	Check and lubricate drive & table height adj. chains.
	Change gear box oil. NOTE: First oil change should be done after the first 20 hours of use, then yearly afterwards.
	Replace with 80W-90W gear oil.

Cleaning

Keep excess wood chips and sawdust off of machine, and wipe off the remaining dust with a dry cloth to ensure moisture from wood dust does not remain on bare metal surfaces. To help prevent rusting and smooth material feed, treat all unpainted cast iron and steel with a non-staining lubricant after cleaning.

Lubrication

BEARINGS: This planer features factory-sealed bearings and requires no lubrication during its lifetime. Should a bearing fail, your planer will probably develop a noticeable rumble and or vibration, which will increase when the machine is put under load. Do not continue use of your planer until you have replaced the worn bearing as you may damage your planer. Bearings are standard sizes and can be replaced through local suppliers.

COLUMNS & LEAD SCREWS: The outside of the four columns should be lubricated weekly with SAE 30W oil. The four lead screws inside the columns should be lubricated with general purpose grease once a month.

TABLE HEIGHT ADJUSTMENT CHAIN: should be inspected monthly and lubricated with general purpose grease as needed.

WORM GEAR: The worm gear for changing the table height should be inspected monthly and lubricated with general purpose grease when needed. Remove the worm gear box to inspect. See parts diagram for location.

GEAR BOX: Gear box oil should be changed after the first 20 hours of operation. It is not necessary to remove the chain drive cover to access the fill/drain plugs, but doing so will give you easier access. Replace with 80W-90W gear oil. Inspect levels periodically and change yearly. Replace gear oil more frequently under heavy use. **NOTE:** Remove the cover and inspect the internal gears for wear. (Figure 36)

DRIVE CHAIN: The drive chain should be inspected and lubricated monthly. Check sprocket/gear, chain and cotter pin during inspection. Use a general purpose grease. Some chains will have master links instead of cotter pins.

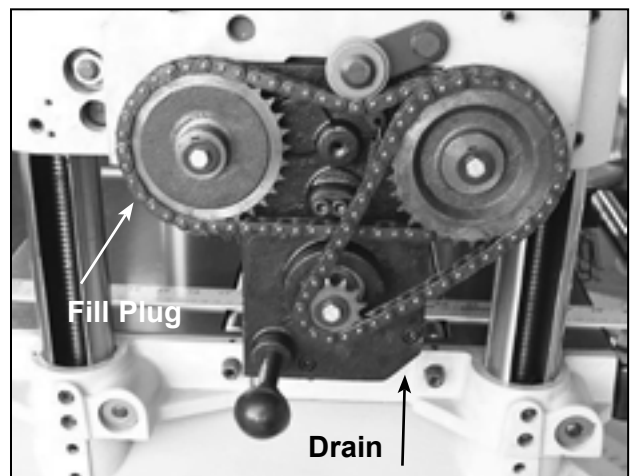
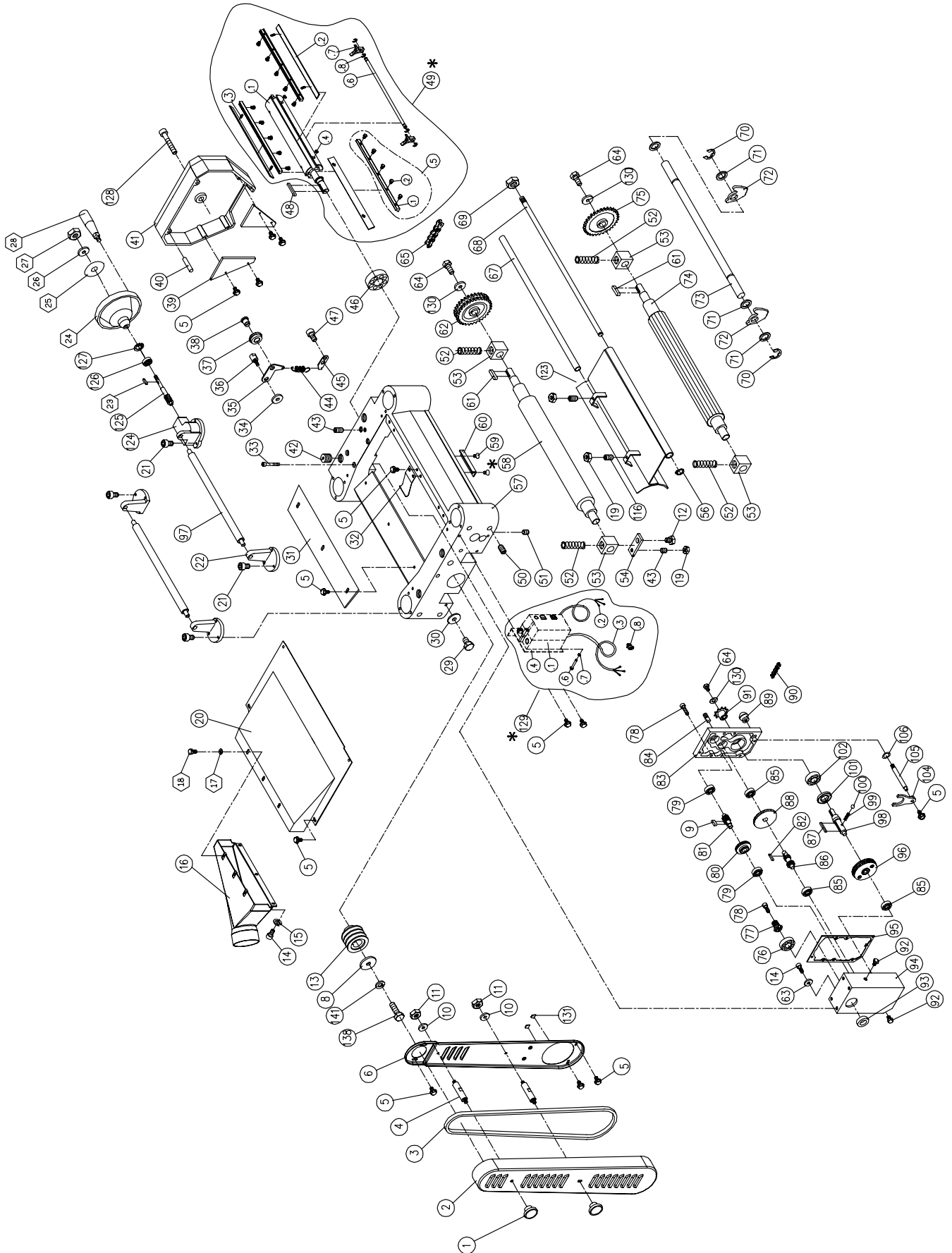

Figure 36

Parts Breakdown

PNR 14-150



Parts Listing

PNR 14-150

Key	Part No.	Descriptions	Qty
1	230118-000	NUT	2
2	170871-133	PULLEY COVER	1
3	014010-000	BELT	3
4	380147-901	BOLT	2
5	000902-102	SCREW W/WASHER	24
6	170432-133	PULLEY GUARD	1
7	000003-204	HEX. HEAD SCREW	6
7	000003-204	HEX. HEAD SCREW	4
8	006001-043	WASHER	1
9	012003-003	KEY	1
10	006002-046	WASHER	2
11	009005-200	HEX. NUT	2
12	000003-104	HEX. HEAD SCREW	4
13	050273-901	MACHINE PULLEY	1
14	000103-103	CAP SCREW	1
16	922372-000	DUST COLLECT ASSY	1
16.1	250345-615	DUST COLLECT	1
16.2	170813-901	CLIPER	3
16.5	001603-201	ROUND HEAD SCREW W/WASHER	6
19	008005-100	NUT	6
20	170419-133	UPPER COVER	1
21	000103-107	CAP SCREW	20
22	050288-133	ROLLER STAND	3
23	012002-004	KEY	2
24	240016-000	HAND WHEEL	1
25	570890-000	LABEL	1
26	006002-067	WASHER	1
27	008008-200	NUT	7
28	230114-906	HANDLE	1
29	000002-101	HEX. HEAD SCREW	4
30	006001-056	WASHER	16
31	250158-617	CHIP DEFLECTOR PLATE	1
32	270015-901	PLATE SPRING	3
33	000104-114	CAP SCREW	4
34	006001-041	WASHER	9
35	170405-901	BRACKET	1
36	290039-901	SHAFT	1
37	130071-000	IDLE PULLEY	1
38	360349-902	SHAFT	1
39	170424-905	SAFETY PLATE	2
40	011004-102	SPRING PIN	2
41	050276-133	COVER	1
42	380200-901	SCREW	4
43	000203-106	SET SCREW	5
44	280050-000	SPRING	1
45	170406-901	HANGER	1
46	030209-000	BALL BEARING	1

Key	Part No.	Descriptions	Qty
47	000103-102	CAP SCREW	2
48	012204-001	KEY	1
49	922354-000	CUTTERHEAD ASSEMBLY	1
49.1	220032-000	CUTTER HEAD	1
49.2	210124-000	KNIVES	3
49.3	280052-000	SPRING	6
49.4	000701-103	SET SCREW	6
49.5	922357-000	KNIFE LOCKING BAR ASSY	3
.1	380017-901	KNIFE LOCKING BAR	1
.2	000003-119	HEX. HEAD SCREW	5
49.6	360365-902	CLUB OF KNIFE GAGE	1
49.7	130042-903	KNIFE GAGE	2
49.8	010206-000	RETAINING RING	4
50	000205-101	SET SCREW	16
51	000204-103	SET SCREW	6
51	000204-103	SET SCREW	1
52	280051-000	SPRING	4
53	130039-000	BUSH	4
54	170408-902	PLATE	4
56	010003-000	RETAINING RING	1
57	050282-133	HEAD CASTING	1
58	360383-000	OUTFEED ROLLER	1
59	000402-202	FLAT HD MACH SCR	2
60	170409-901	CUT LIMITER PLATE	1
61	012202-001	KEY	2
62	070012-000	SPROCKET	1
63	006001-020	WASHER	1
64	000002-103	HEX. HEAD SCREW	3
65	016306-000	CHAIN	1
67	360351-000	SHAFT	1
68	360366-902	LOCKING BOLT	1
69	008009-100	NUT	1
70	010209-000	RETAINING RING	2
71	250160-615	COLLER	40
72	170411-905	ANTI-KICK FINGER	39
73	360352-000	SHAFT	1
74	360353-000	INFEED ROLLER	1
75	070013-000	SPROCKET	1
76	030109-000	BALL BEARING	1
77	320196-000	GEAR	1
78	000103-108	CAP SCREW	6
79	030701-000	BALL BEARING	2
80	320197-000	GEAR	1
81	320160-000	SHAFT	1
82	012003-002	KEY	1
83	050280-133	COVER	1
84	360355-901	PIN	2

Key	Part No.	Descriptions	Qty
85	030304-000	BALL BEARING	3
86	320205-000	SHAFT	1
87	012004-003	KEY	1
88	320198-000	GEAR	1
89	250372-615	KNOB	1
90	016303-000	CHAIN	1
91	150008-000	SPROCKET	1
92	043401-000	OIL PLUG	2
93	043608-000	OIL SEAL	1
94	050281-133	GEAR BOX	1
95	340012-615	PACKING PIECE	1
96	922351-000	GEAR ASSEMBLY	1
	320199-000	GEAR	1
	320200-000	GEAR	1
	000103-103	CAP SCREW	2
97	360375-902	ROLLER	2
98	360357-901	SHAFT	1
99	280052-000	SPRING	1
100	017002-000	BALL	1
101	043505-000	OIL SEAL	1
102	030306-000	BALL BEARING	1
103	921349-000	EXTENSION ROLLER ASSEMBLY	2
	170416-008	ROLLER FRAME	1
	190113-906	ROLLER	3
	360686-901	SHAFT	3
	250251-615	ROLLER LINER	6
	000002-201	HEX. HEAD SCREW	6
	006001-020	WASHER	6
	006304-100	SPRING WASHER	6
	520001-235		1
	006002-071	WASHER	6
104	070014-000	CLUTCH	1
105	360358-901	HANDLE	1
106	043303-000	O RING	1

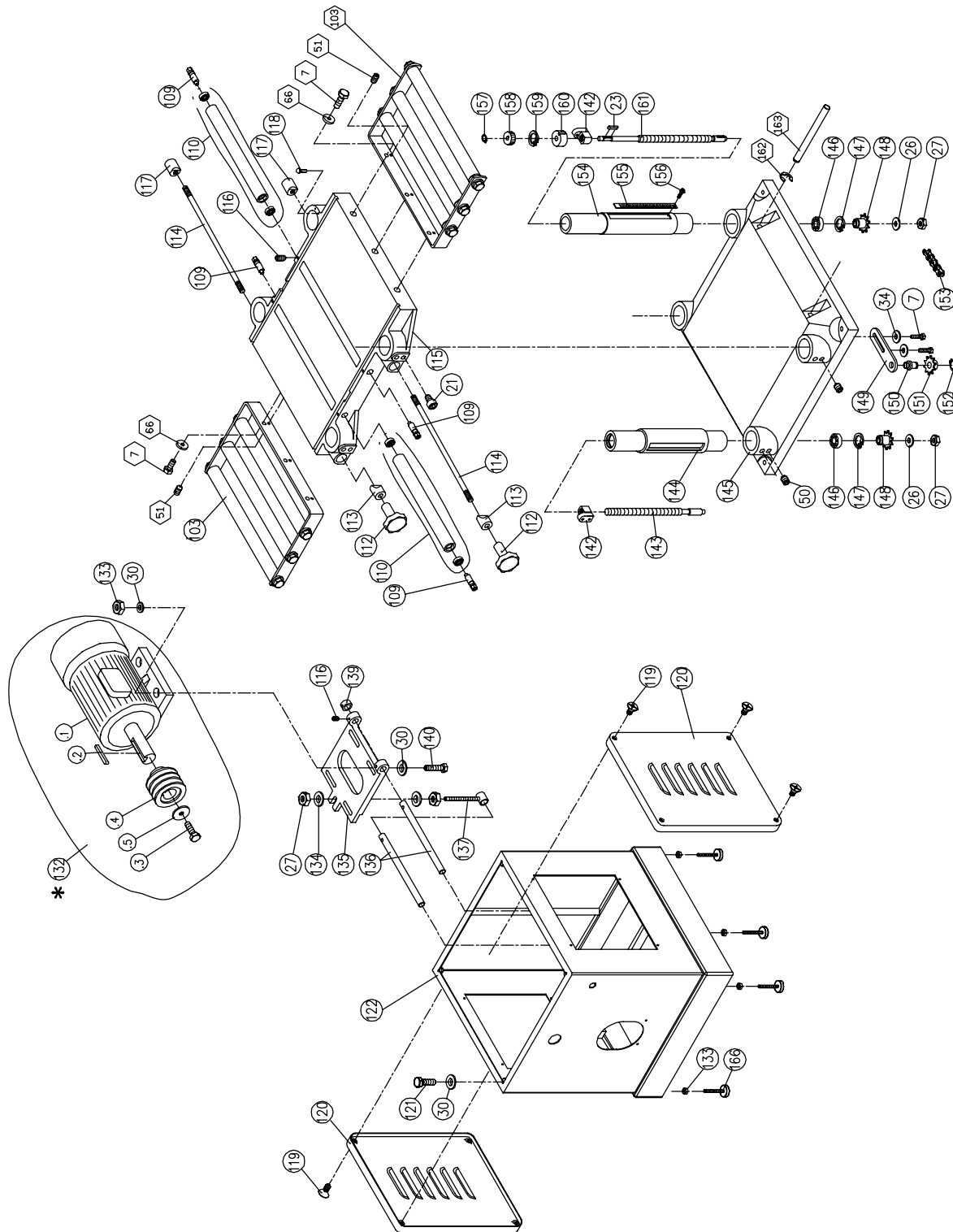

Parts Listing

PNR 14-150

Key	Part No.	Descriptions	Qty
108	041503-017	PLASTIC PLATE	1
109	360360-902	ECCENTRIC SHAFT	4
110	921209-000	ROLLER ASSEMBLY	2
	030301-000	BALL BEARING	2
	190005-000	ROLLER	1
112	230115-000	KNOB	2
113	130037-000	LOCK BAR	2
114	360350-902	LOCKING BOLT	2
115	050283-133	MIDDLE TABLE	1
116	000203-104	SET SCREW	10
117	130038-000	LOCK BAR	2
118	002301-201	RIVET	2
119	000403-104	FLAT HD MACH SCR	8
120	170445-133	COVER	2
121	000003-109	HEX. HEAD SCREW	4
122	172247-133	STAND	1
123	170410-019	CHIP BRACKET	1
124	050289-133	WORM GEAR BOX	1
125	320202-000	LOCKING BOLT	1
126	030303-000	BALL BEARING	1
127	010101-000	RETAINING RING	1
128	000104-113	CAP SCREW	1
129	937385-000	MAGNETIC SWITCH	1
.1	821002-012	SWITCH OPTZONAL	1
.2	473003-010	CONNECT CORD	1
.3	473003-016	POWER CORD	1
.4	170440-904	SWITCH PLATE	1
.5	003303-203	MACH SCREW	2
.6	009003-200	NUT	2
.7	006502-100	TOOTH WASHER	2
.8	021601-000	RELIEF BUSHING	2
130	006001-021	WASHER	3
131	200013-615	PLASTIC PLATE	2
132	900144-000	MOTOR ASSEMBLY	1
.1	601017-000	MOTOR	1
.2	012202-002	KEY	1
.3	048201-201	HEX NUT	1
.4	050271-901	MOTOR PULLEY	1
.5	006001-043	WASHER	1
133	008006-100	NUT	8
134	006001-091	WASHER	2

Key	Part No.	Descriptions	Qty
135	050287-008	MOTOR PLATE	1
136	360374-902	SUPPORT SHAFT	2
137	380148-901	ADJUSTING ROD ASSEMBLY	1
138	048201-104	HEX. SCREW	1
139	380049-901	COLLER	1
140	000003-106	HEX. HEAD SCREW	4
141	006305-100	SPRING WASHER	1
142	130043-000	NUT	4
143	360359-000	LEAD SCREW	3
144	050284-000	COLUMN	3
145	050285-133	BASE	1
146	030305-000	BALL BEARING	4
147	010103-000	RETAINING RING	4
148	150010-000	SPROCKET	4
149	170413-901	SPROCKET IDLER	1
150	360362-902	SHAFT	1
151	150009-000	SPROCKET	1
152	010006-000	RETAINING RING	1
153	016220-000	CHAIN	1
154	050286-000	COLUMN	1
155	570889-000	SCALE	1
156	000301-201	MACH SCREW	1
157	010001-000	RETAINING RING	1
158	320201-000	GEAR	1
159	010104-000	RETAINING RING	1
160	130041-000	BUSH	1
161	360372-000	LEAD SCREW	1
162	010208-000	RETAINING RING	4
163	360367-902	LIFTING HANDLES	4
166	230041-000	FOOT SCREW	4
172	040006-000	HEX. WRENCH	1
173	040005-000	HEX. WRENCH	1
174	040004-000	HEX. WRENCH	1
175	040003-000	HEX. WRENCH	1
176	040201-000	OPEN WRENCH	1
177	040204-000	OPEN WRENCH	1

Pioneer Supply International, Inc. Limited Warranty

Pioneer Supply International warrants to Buyer that its machinery is free from defects in workmanship and material for a period of two years from the original purchase date and that its hand tools and accessories are free from defects in workmanship and material for a period of ninety days from the original purchase date. Pioneer Supply's machinery, hand tools and accessories are collectively referred to as "Product" or "Products". Buyer of the Product assumes all liability and risk resulting from use of the Product and Pioneer Supply does not warrant or represent that the Product complies with the laws or statutes of any state. This warranty only covers the initial Buyer and the Product is not warranted against normal wear, misuse or abuse resulting from improper use, accidents, negligence, repairs, alterations or lack of maintenance. This Limited Warranty is void if the Product is changed from its original state in any way. This is Buyer's sole and exclusive warranty. Pioneer Supply's liability is limited to and is not to exceed the purchase price of the Product.

PIONEER SUPPLY DISCLAIMS AND MAKES NO WARRANTIES OF MERCHANTABILITY OR FITNESS FOR A PARTICULAR PURPOSE. PIONEER SUPPLY SHALL IN NO EVENT BE LIABLE FOR DEATH, INJURIES TO PERSONS OR PROPERTY, OR FOR INCIDENTAL, CONTINGENT, SPECIAL, OR CONSEQUENTIAL DAMAGES ARISING FROM THE USE OF THE PRODUCT. THE FOREGOING WARRANTIES AND REMEDIES FOR THEIR BREACH ARE PIONEER SUPPLY'S SOLE AND EXCLUSIVE WARRANTY OBLIGATIONS, BOTH EXPRESS AND IMPLIED, WITH RESPECT TO ITS SALE OF ITS GOODS.

Pioneer Supply's breach of its warranty obligations under any sale of Products shall not provide a basis for termination or rescission of the agreement of sale. Buyer agrees that the State of Oregon, County of Marion, is the exclusive venue for any claim or legal action brought against Pioneer Supply arising from purchase of Products. Some states do not allow limitations on how long the implied warranty lasts, or the exclusion or limitation of incidental or consequential damages, so the above exclusions or limitations may not apply to you.

Pioneer Supply International Inc.

PO Box 12308

Salem, OR 97309

PIONEER SUPPLY INTERNATIONAL, INC. WARRANTY CARD

Name: _____

Order No: _____

Address: _____

Invoice No: _____

City: _____ State: _____ Zip: _____

Model No: _____

Phone: _____ E-Mail: _____

Serial No: _____

Please help us serve you better. All information is confidential and is used for internal purposes only. We do not keep track of individual information other than for warranty purposes and are looking at total figures not individual records. We do not sell or market information from this questionnaire to 3rd parties.

1. Does this product represent good value? Yes Somewhat No
2. Would you recommend Pioneer products to a friend? Yes No
3. Can we use your name as a reference for other customers? (We don't use names more than 3 times)
 Yes No
4. It this machine for : (check one box)

<input type="checkbox"/> Construction business	<input type="checkbox"/> Woodworking business	<input type="checkbox"/> Other business
<input type="checkbox"/> Home shop	<input type="checkbox"/> Jobsite only	
5. How did you hear about us? (check one box)

<input type="checkbox"/> Visited Store	<input type="checkbox"/> Magazine ad	<input type="checkbox"/> Sales flyer
<input type="checkbox"/> Internet	<input type="checkbox"/> Card deck	<input type="checkbox"/> Friend
6. Which of the following magazines do you subscribe to? (check as many as applicable)

<input type="checkbox"/> Cabinetmaker	<input type="checkbox"/> American Woodworker	<input type="checkbox"/> Practical Home Owner	<input type="checkbox"/> Wooden Boat
<input type="checkbox"/> FDM	<input type="checkbox"/> Woodworkers Journal	<input type="checkbox"/> Wood Magazine	<input type="checkbox"/> Popular Mechanics
<input type="checkbox"/> Outdoor Life	<input type="checkbox"/> Today's Homeowner	<input type="checkbox"/> Field & Stream	<input type="checkbox"/> Tool of the Trade
<input type="checkbox"/> Popular Mechanics	<input type="checkbox"/> Fine Home Building	<input type="checkbox"/> Popular Science	<input type="checkbox"/> Wood Shop News
<input type="checkbox"/> Remodeling	<input type="checkbox"/> Fine Woodworking	<input type="checkbox"/> Popular Woodworking	<input type="checkbox"/> Workbench
<input type="checkbox"/> Family Handyman	<input type="checkbox"/> Home Handyman	<input type="checkbox"/> Journal of Light Contr.	<input type="checkbox"/> Log Home Living
7. Please rate your skill level (check one)

<input type="checkbox"/> Professional	<input type="checkbox"/> Advanced	<input type="checkbox"/> Hobbyist	<input type="checkbox"/> D.I.Y.	<input type="checkbox"/> Beginner
---------------------------------------	-----------------------------------	-----------------------------------	---------------------------------	-----------------------------------
8. How long have you been involved with woodworking or construction? Circle woodworking and or construction.

<input type="checkbox"/> 20 yrs or more	<input type="checkbox"/> 10 to 20 yrs	<input type="checkbox"/> 5 to 10 yrs	<input type="checkbox"/> 2 to 5 yrs	<input type="checkbox"/> 1 to 2 yrs
---	---------------------------------------	--------------------------------------	-------------------------------------	-------------------------------------
9. What is your age group? (check one)

<input type="checkbox"/> 18 to 29	<input type="checkbox"/> 30 to 39	<input type="checkbox"/> 40 to 49	<input type="checkbox"/> 50 to 59
<input type="checkbox"/> 60 to 69	<input type="checkbox"/> 70 to 79	<input type="checkbox"/> 80+	
10. Do you own a:

<input type="checkbox"/> Business	<input type="checkbox"/> Home	<input type="checkbox"/> Second Home	<input type="checkbox"/> Rental Unit	<input type="checkbox"/> Land
-----------------------------------	-------------------------------	--------------------------------------	--------------------------------------	-------------------------------
11. What is your average house hold income?

<input type="checkbox"/> Less than \$29,999	<input type="checkbox"/> \$30,000 to \$39,999	<input type="checkbox"/> \$40,000 to \$49,999	<input type="checkbox"/> \$50,000 to \$59,999
<input type="checkbox"/> \$60,000 to \$69,999	<input type="checkbox"/> \$70,000 to \$79,999	<input type="checkbox"/> \$80,000 to \$89,999	<input type="checkbox"/> \$90,000 to \$99,999
<input type="checkbox"/> \$100,000 to \$109,999	<input type="checkbox"/> \$110,000 to \$119,999	<input type="checkbox"/> \$120,000 to \$129,999	<input type="checkbox"/> \$130,000+
12. Other Comments

Fold warranty sheet over, seal the edges, attach the proper postage and place in the mail.

IMPORTANT:

Mail in your
Warranty Card
to help us
serve you better.

**Pioneer Supply International Inc.
PO Box 12308
Salem, OR 97309**

Free Manuals Download Website

<http://myh66.com>

<http://usermanuals.us>

<http://www.somanuals.com>

<http://www.4manuals.cc>

<http://www.manual-lib.com>

<http://www.404manual.com>

<http://www.luxmanual.com>

<http://aubethermostatmanual.com>

Golf course search by state

<http://golfingnear.com>

Email search by domain

<http://emailbydomain.com>

Auto manuals search

<http://auto.somanuals.com>

TV manuals search

<http://tv.somanuals.com>