

Pioneer *sound.vision.soul*

**AUDIO/VIDEO MULTI-CHANNEL
RECEIVER**

VSX-517-S/-K

VSX-817-S/-K

Operating Instructions

IMPORTANT



The lightning flash with arrowhead symbol, within an equilateral triangle, is intended to alert the user to the presence of uninsulated "dangerous voltage" within the product's enclosure that may be of sufficient magnitude to constitute a risk of electric shock to persons.

CAUTION

RISK OF ELECTRIC SHOCK
DO NOT OPEN

CAUTION:
TO PREVENT THE RISK OF ELECTRIC SHOCK, DO NOT REMOVE COVER (OR BACK). NO USER-SERVICEABLE PARTS INSIDE. REFER SERVICING TO QUALIFIED SERVICE PERSONNEL.



The exclamation point within an equilateral triangle is intended to alert the user to the presence of important operating and maintenance (servicing) instructions in the literature accompanying the appliance.

D3-4-2-1-1_En-A

NOTE: This equipment has been tested and found to comply with the limits for a Class B digital device, pursuant to Part 15 of the FCC Rules. These limits are designed to provide reasonable protection against harmful interference in a residential installation. This equipment generates, uses, and can radiate radio frequency energy and, if not installed and used in accordance with the instructions, may cause harmful interference to radio communications. However, there is no guarantee that interference will not occur in a particular installation. If this equipment does cause harmful interference to radio or television reception, which can be determined by turning the equipment off and on, the user is encouraged to try to correct the interference by one or more of the following measures:

- Reorient or relocate the receiving antenna.
- Increase the separation between the equipment and receiver.
- Connect the equipment into an outlet on a circuit different from that to which the receiver is connected.
- Consult the dealer or an experienced radio/TV technician for help.

D8-10-1-2_En

Information to User

Alteration or modifications carried out without appropriate authorization may invalidate the user's right to operate the equipment.

D8-10-2_En

CAUTION: This product satisfies FCC regulations when shielded cables and connectors are used to connect the unit to other equipment. To prevent electromagnetic interference with electric appliances such as radios and televisions, use shielded cables and connectors for connections.

D8-10-3a_En

Replacement and mounting of an AC plug on the power supply cord of this unit should be performed only by qualified service personnel.

IMPORTANT: THE MOULDED PLUG

This appliance is supplied with a moulded three pin mains plug for your safety and convenience. A 10 amp fuse is fitted in this plug. Should the fuse need to be replaced, please ensure that the replacement fuse has a rating of 10 amps and that it is approved by ASTA or BSI to BS1362.

Check for the ASTA mark  or the BSI mark  on the body of the fuse.

If the plug contains a removable fuse cover, you must ensure that it is refitted when the fuse is replaced. If you lose the fuse cover the plug must not be used until a replacement cover is obtained. A replacement fuse cover can be obtained from your local dealer.

If the fitted moulded plug is unsuitable for your socket outlet, then the fuse shall be removed and the plug cut off and disposed of safely. There is a danger of severe electrical shock if the cut off plug is inserted into any 13 amp socket.

If a new plug is to be fitted, please observe the wiring code as shown below. If in any doubt, please consult a qualified electrician.

IMPORTANT: The wires in this mains lead are coloured in accordance with the following code:

Blue : Neutral Brown : Live

As the colours of the wires in the mains lead of this appliance may not correspond with the coloured markings identifying the terminals in your plug, proceed as follows:

The wire which is coloured BLUE must be connected to the terminal which is marked with the letter **N** or coloured BLACK.

The wire which is coloured BROWN must be connected to the terminal which is marked with the letter **L** or coloured RED.

How to replace the fuse: Open the fuse compartment with a screwdriver and replace the fuse.

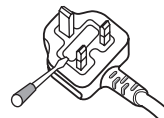

D3-4-2-1-2-2_B_En

Voltage selector

You can find the voltage selector switch on the rear panel of multi-voltage models.

The factory setting for the voltage selector is 220 V. Please set it to the correct voltage for your country or region.

- Saudi Arabia operates on 127 V and 220 V mains voltage. Please set to the correct voltage before using.
- For Taiwan, please set to 110 V before using.
- For Mexico, please set to 120 V to 127 V before using.

Before changing the voltage, disconnect the AC power cord. Use a medium size screwdriver to change the voltage selector switch.

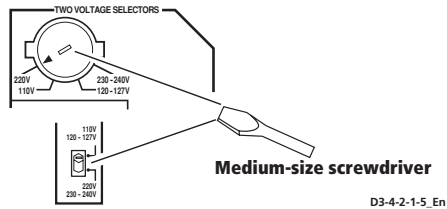

For Taiwan exclusively

Taiwanese two pin flat-bladed plug

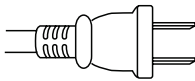

VENTILATION CAUTION

When installing this unit, make sure to leave space around the unit for ventilation to improve heat radiation (at least 40 cm at top, 10 cm at rear, and 20 cm at each side).

WARNING

Slots and openings in the cabinet are provided for ventilation to ensure reliable operation of the product, and to protect it from overheating. To prevent fire hazard, the openings should never be blocked or covered with items (such as newspapers, table-cloths, curtains) or by operating the equipment on thick carpet or a bed.

D3-4-2-1-7b_A_En

WARNING

This equipment is not waterproof. To prevent a fire or shock hazard, do not place any container filled with liquid near this equipment (such as a vase or flower pot) or expose it to dripping, splashing, rain or moisture.

D3-4-2-1-3_A_En

WARNING

To prevent a fire hazard, do not place any naked flame sources (such as a lighted candle) on the equipment.

D3-4-2-1-7a_A_En

WARNING

Before plugging in for the first time, read the following section carefully.

The voltage of the available power supply differs according to country or region. Be sure that the power supply voltage of the area where this unit will be used meets the required voltage (e.g., 230 V or 120 V) written on the rear panel.

D3-4-2-1-4_En

CAUTION

The STANDBY/ON switch on this unit will not completely shut off all power from the AC outlet. Since the power cord serves as the main disconnect device for the unit, you will need to unplug it from the AC outlet to shut down all power. Therefore, make sure the unit has been installed so that the power cord can be easily unplugged from the AC outlet in case of an accident. To avoid fire hazard, the power cord should also be unplugged from the AC outlet when left unused for a long period of time (for example, when on vacation).

If the AC plug of this unit does not match the AC outlet you want to use, the plug must be removed and appropriate one fitted. Replacement and mounting of an AC plug on the power supply cord of this unit should be performed only by qualified service personnel. If connected to an AC outlet, the cut-off plug can cause severe electrical shock. Make sure it is properly disposed of after removal. The equipment should be disconnected by removing the mains plug from the wall socket when left unused for a long period of time (for example, when on vacation).

D3-4-2-1a_A_En

Operating Environment

Operating environment temperature and humidity: +5 °C to +35 °C (+41 °F to +95 °F); less than 85 %RH (cooling vents not blocked)

Do not install this unit in a poorly ventilated area, or in locations exposed to high humidity or direct sunlight (or strong artificial light)

D3-4-2-1-7c_A_En

This product is for general household purposes. Any failure due to use for other than household purposes (such as long-term use for business purposes in a restaurant or use in a car or ship) and which requires repair will be charged for even during the warranty period.

K041_En

Contents

01 Before you start

Checking what's in the box	6
Loading the batteries	6
Operating range of remote control unit.....	7
Installing the receiver	7

02 5 minute guide

Introduction to home theater	8
Listening to Surround Sound	8
Using the Quick Setup	9
Automatically setting up for surround sound (MCACC).....	10
Other problems during Auto MCACC.....	11

03 Connecting up

Making cable connections	12
Analog audio cables.....	12
Digital audio cables	12
Video cables.....	12
Connecting a TV and DVD player	13
Connecting the multichannel analog outputs.....	14
Connecting a satellite receiver or other digital set-top box	14
Connecting other audio components	15
About the WMA9 Pro decoder	15
Connecting other video components	16
Using the component video jacks.....	16
Connecting to the front panel video terminal	17
Connecting to the front panel audio mini jack	17
Connecting antennas	18
Using external antennas.....	18
Connecting the speakers	19
Speaker terminals	20
Hints on speaker placement.....	20
Speaker placement diagrams.....	21

04 Controls and displays

Front panel	22
Display	24
Remote control (VSX-817).....	25
Remote control (VSX-517).....	28

05 Listening to your system

Auto playback	31
Listening in surround sound	31
Using the Advanced surround effects	32
Setting the effect options	32
Listening in stereo.....	33
Using Front Stage Surround Advance.....	33
Using Stream Direct.....	34

Listening with Acoustic Calibration EQ	34
Choosing the input signal	34
Using surround back channel processing.....	35
Using Virtual Surround Back (VSB).....	35
Using Phase Control	36
Using Midnight and Loudness.....	37
Enhancing dialog	37
Using the tone controls.....	37
Using the Sound Retriever.....	37
Playing other sources	37
Selecting the multichannel analog inputs	38
Selecting the front audio inputs	38

06 The System Setup menu

Using the System Setup menu	39
Surround back speaker setting	39
Manual MCACC speaker setup	40
Fine Channel Level	40
Fine Speaker Distance	41
Acoustic Calibration EQ	41
Manual speaker setup.....	43
Speaker setting.....	43
Crossover network	44
Channel level	44
Speaker Distance	45
The Input Assign menu	45
The Other setup menu.....	46
Dynamic Range Control Setup	46
Dual Mono Setup	46
LFE Attenuator Setup	46

07 Using the tuner

Listening to the radio.....	47
Tuning directly to a station	47
Saving station presets.....	47
Naming station presets.....	47
Listening to station presets.....	48
Changing the frequency step.....	48

08 Making recordings

Making an audio or a video recording	49
--	----

09 Controlling the rest of your system

Setting the remote to control other components	50
Selecting preset codes directly	50
Direct function	51
Clearing all the remote control settings.....	51
Controls for TVs.....	52
Controls for other components	53
Preset Code List	55

10 Other connections

Second Zone speaker B setup.....	56
Switching the speaker system	56
Bi-amping your front speakers	57
Bi-wiring your speakers.....	57

11 Additional information

Troubleshooting	58
Resetting the main unit.....	60
Switching the speaker impedance.....	60
Power cord caution.....	60
Specifications	61
Cleaning the unit	62

Chapter 1: Before you start

Checking what's in the box

Please check that you've received the following supplied accessories:

- AM loop antenna
- FM wire antenna
- AA size IEC R6 dry cell batteries (to confirm system operation) x2
- Remote control
- Setup microphone (*VSX-817 model only*)
- Power cords (make sure you use the correct cord for your country/region):
VSX-517/817-K (black models)
Round 2-pin type and Australian type
VSX-517/817-S (silver models)
Round 2-pin type, flat blade 2-pin type and UK 3-pin type (Except Australian model)
- Power plug adaptor (*VSX-517/817-K only*)
- J-shaped plug
- These operating instructions

Loading the batteries

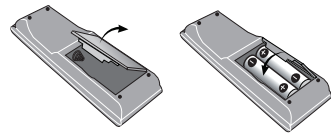

Illustration shows the VSX-517 model

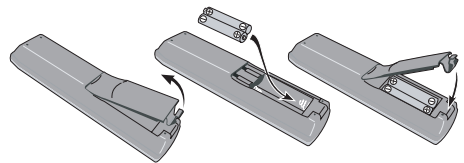

Illustration shows the VSX-817 model

Important

Incorrect use of batteries may result in such hazards as leakage and bursting. Observe the following precautions:

- Never use new and old batteries together.
- Insert the plus and minus sides of the batteries properly according to the marks in the battery case.
- Batteries with the same shape may have different voltages. Do not use different batteries together.
- When disposing of used batteries, please comply with governmental regulations or environmental public instruction's rules that apply in your country or area.



WARNING

- Do not use or store batteries in direct sunlight or other excessively hot place, such as inside a car or near a heater. This can cause batteries to leak, overheat, explode or catch fire. It can also reduce the life or performance of batteries.

Operating range of remote control unit

The remote control has a range of about 7 meters. It may not work properly if:

- There are obstacles between the remote control and the receiver's remote sensor.
- Direct sunlight or fluorescent light is shining onto the remote sensor.
- The receiver is located near a device that is emitting infrared rays.
- The receiver is operated simultaneously with another infrared remote control unit.

Installing the receiver

- When installing this unit, make sure to put it on a level and stable surface.

Don't install it on the following places:

- on a color TV (the screen may distort)
- near a cassette deck (or close to a device that gives off a magnetic field). This may interfere with the sound.
- in direct sunlight
- in damp or wet areas
- in extremely hot or cold areas
- in places where there is vibration or other movement
- in places that are very dusty
- in places that have hot fumes or oils (such as a kitchen)

Chapter 2:

5 minute guide

Introduction to home theater

Home theater refers to the use of multiple audio tracks to create a surround sound effect, making you feel like you're in the middle of the action or concert. The surround sound you get from a home theater system depends not only on your speaker setup, but also on the source and the sound settings of the receiver.

This receiver will automatically decode multichannel Dolby Digital, DTS, or Dolby Surround sources according to your speaker setup. In most cases, you won't have to make changes for realistic surround sound, but other possibilities (like listening to a CD with multichannel surround sound) are explained in *Listening to your system* on page 31.

Listening to Surround Sound

This receiver was designed with the easiest possible setup in mind, so with the following quick setup guide, you should have your system hooked up for surround sound in no time at all. In most cases, you can simply leave the receiver in the default settings.

- Be sure to complete all connections before connecting to an AC power source.

1 Connect your TV and DVD player.

See *Connecting a TV and DVD player* on page 13 to do this. For surround sound, you'll want to hook up using a digital connection from the DVD player to the receiver.

2 Connect your speakers and place them for optimal surround sound.

See *Connecting the speakers* on page 19.

Where you place the speakers will have a big effect on the sound. Place your speakers as shown below for the best surround sound effect. Also see *Hints on speaker placement* on page 20 for more on this.

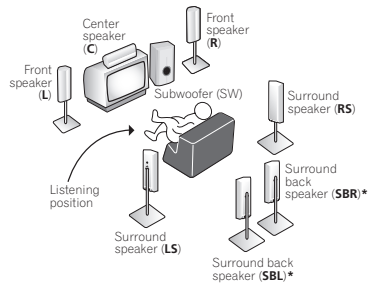

* VSX-817 model only

3 Plug in and switch on the receiver, followed by your DVD player, subwoofer and TV.

Make sure you've set the video input on your TV to this receiver. Check the manual that came with the TV if you don't know how to do this.

4 VSX-517 model – Press QUICK SETUP on the front panel to specify your speaker setup, room size and listening position.

Use the **MULTI JOG** dial to select and **ENTER** to confirm your selection. See *Using the Quick Setup* below for more on this.

VSX-817 model – Use the display automatic MCACC setup to set up your system.

See *Automatically setting up for surround sound (MCACC)* below for more on this.

5 Play a DVD, and adjust the volume.

Make sure that **DVD** is showing in the receiver's display, indicating that the DVD input is selected. If it isn't, press **DVD** (VSX-517 model)/**DVD/LD** (VSX-817 model) on the remote to set the receiver to the DVD input.

There are several other sound options you can select. See *Listening to your system* on page 31 for more on this.¹ See also *The System Setup menu* on page 39 for more setup options.

Using the Quick Setup

VSX-517 model only

You can use the Quick Setup to get your system up and running with just a few button presses. The receiver automatically makes the necessary settings after you have selected your speaker setup, room size and listening position.

If you want to make more specific settings, refer to *The System Setup menu* on page 39.

Use the front panel controls for the steps below.

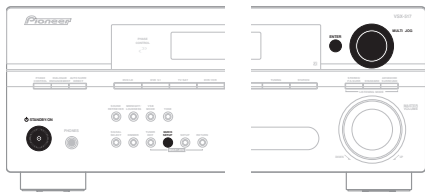

1 If the receiver is off, press
⏻ STANDBY/ON to turn the power on.

2 Press QUICK SETUP.

3 Use the MULTI JOG dial to choose your subwoofer setting.

Select **YES** or **NO**, depending on whether you've connected a subwoofer.

4 Press ENTER.

5 Use the MULTI JOG dial to choose your speaker setup.

If you selected **YES** for the subwoofer setting in step 3, the following choices are available:

2.1ch – 3.1ch – 4.1ch – 5.1ch

If you selected **NO** for the subwoofer setting in step 3, the following choices are available:

2.0ch – 3.0ch – 4.0ch – 5.0ch

- Check the table below to find the speaker setup that corresponds with your system.

	Front Speakers	Center Speaker	Surround Speakers	Sub Woofer
2.0 ch	✓			
2.1 ch	✓			✓
3.0 ch	✓	✓		
3.1 ch	✓	✓		✓
4.0 ch	✓		✓	
4.1 ch	✓		✓	✓
5.0 ch	✓	✓	✓	
5.1 ch	✓	✓	✓	✓

6 Press ENTER.

7 Use the MULTI JOG dial to choose your room size.

Depending on the distance of your speakers from the listening position, choose between small, medium, or large (**S**, **M** or **L**), **M** being an average-sized room.

8 Press ENTER.

9 Use the MULTI JOG dial to choose your listening position.

You can cycle between the following choices:

- **FWD** – If you are nearer to the front speakers than the surround speakers
- **MID** – If you are equal distance from the front and surround speakers
- **BACK** – If you are nearer to the surround speakers than the front speakers

10 Press ENTER to confirm your setup.

The display shows the speaker setup, room size and listening position that you have selected.

Note

¹ Depending on your DVD player or source discs, you may only get digital 2 channel stereo and analog sound. In this case, the listening mode must be set to **STANDARD** (it should already be set – see *Listening in surround sound* on page 31 if you need to do this) if you want multichannel surround sound.

Automatically setting up for surround sound (MCACC)

VSX-817 model only

The Auto Multi-Channel Acoustic Calibration (MCACC) setup measures the acoustic characteristics of your listening area, taking into account ambient noise, speaker size and distance, and tests for both channel delay and channel level. After you have set up the microphone provided with your system, the receiver uses the information from a series of test tones to optimize the speaker settings and equalization for your particular room.



Important

- The Auto MCACC Setup will overwrite any existing speaker settings you've made.
- Make sure the headphones are unplugged.



Caution

- The test tones used in the Auto MCACC Setup are output at high volume.

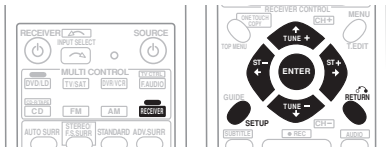

1 Connect the microphone to the MCACC/AUDIO IN jack on the front panel.

Make sure there are no obstacles between the speakers and the microphone.

Push down on the **PUSH OPEN** tab to access the **MCACC/AUDIO IN** jack.

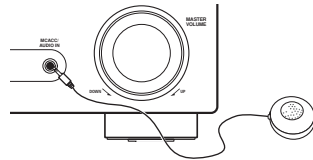

If you have a tripod, use it to place the microphone so that it's about ear level at your normal listening position. Otherwise, place the microphone at ear level using a table or a chair.

2 If the receiver is off, press  RECEIVER to turn the power on.

3 If you have a subwoofer, turn it on.

4 Press RECEIVER on the remote control, then press the SETUP button.

- Press **SETUP** again at any time to exit the System Setup menu.¹

5 Select 'A. MCACC' from the System Setup menu then press ENTER.

6 Make sure 'SB NORM.' is selected then press ENTER.²

Try to be as quiet as possible after pressing **ENTER**. The system outputs a series of test tones to establish the ambient noise level.

If the noise level is too high, **NOISY!** blinks in the display for five seconds. To exit and check the noise levels again, press **SETUP** (see the notes about ambient noise below) or press **ENTER** when you're prompted to **RETRY?**.

- Do not adjust the volume during the test tones. This may result in incorrect speaker settings.

The system now checks the microphone and your speaker setup.

Note

¹ The receiver will automatically exit the current menu after three minutes of inactivity. If you cancel the Auto MCACC Setup at any time, the receiver automatically exits and no settings will be made.

² • If you are planning on bi-amping your front speakers, or setting up a separate speaker system in another room, read through *Surround back speaker setting* on page 39 and make sure to connect your speakers as necessary before continuing to step 7.

If you see an **ERR** message in the display, there may be a problem with your mic or the speaker connections. Turn off the power, and check the problem indicated by the **ERR** message (see below), then try the auto surround setup again.

- **ERR MIC** – Check microphone connection.
- **ERR Fch** – Check front speaker connections.
- **ERR Sch** – Check surround speaker connections.
- **ERR SBch** – Check surround back speaker connection.
- **ERR SW** – Make sure the subwoofer has been switched on and volume on the subwoofer is turned up.

7 When you see CHECK OK in the display, confirm your speaker configuration.

Use **↑/↓** (cursor up/down) to check each speaker in turn. **YES** or **NO** should reflect the actual speakers connected. If the speaker configuration displayed isn't correct, use **←/→** (cursor left/right) to change the setting. When you're finished, go to the next step.

8 Select CHECK OK in the display then press ENTER.

If the display in step 7 is left untouched for 30 seconds, and the **ENTER** button is not pressed in Step 8, the Auto MCACC Setup will start again from the beginning.

The Auto MCACC checks the subwoofer level.

- If the subwoofer output level is too high/low, **SW.VOL.DWN/SW.VOL.UP** blinks in the display for five seconds. To exit and check your subwoofer output level, press **SETUP** or simply press **ENTER** when you're prompted to **RETRY?**

The receiver outputs more test tones to determine the optimum receiver settings for speaker setting, channel level, speaker distance, and Acoustic Calibration EQ.

Note

¹ Depending on the characteristics of your room, sometimes identical speakers with cone sizes of around 12 cm will end up with different size settings. You can correct the setting manually using the *Speaker setting* on page 43.

• The subwoofer distance setting may be farther than the actual distance from the listening position. This setting should be accurate (taking delay and room characteristics into account) and generally does not need to be changed.

² Some older TVs may interfere with operation of the mic. You may want to switch off your TV during the Auto MCACC Setup.

9 The Auto MCACC Setup has finished!

The front panel MCACC indicator lights to show the surround settings are complete.

The settings made in the Auto MCACC Setup should give you excellent surround sound from your system, but it is also possible to adjust these settings manually using the System Setup menu (starting on page 39).¹

Optionally, when you see **SKIP?** you can press **↑/↓** (cursor up/down) to select one of the following options then press **ENTER**, and use **↑/↓** (cursor up/down) to check the settings:

- **CHK SP** – Check the size and number of speakers you've connected (see page 43 for more on this)
- **CHK DIST.** – Check the distance of your speakers from the listening position (see page 45 for more on this)
- **CHK LEVEL** – Check the overall balance of your speaker system (see page 44 for more on this)
- **CHK EQ** – Select either **ALL CH** or **F ALIGN** to check the adjustments to the frequency balance of your speaker system based on the acoustic characteristics of your room (see page 41 for more on this)

10 When you're finished, select 'SKIP?' to go back to the System Setup menu.

- Remember to disconnect the microphone after completing the Auto MCACC Setup.

Other problems during Auto MCACC

If the room environment is not optimal for the Auto MCACC Setup (too much background noise, echo off the walls, obstacles blocking the speakers from the microphone) the final settings may be incorrect. Check for household appliances (air conditioner, fridge, fan, etc.), that may be affecting the environment and switch them off if necessary.² If there are any instructions showing in the front panel display, please follow them.

Chapter 3: Connecting up

Making cable connections

Make sure not to bend the cables over the top of this unit. If this happens, the magnetic field produced by the transformers in this unit may cause a humming noise from the speakers.

Important

- Before making or changing any connections, switch off the power and disconnect the power cord from the AC outlet.
- Before unplugging the power cord, switch the power into standby.

Analog audio cables

Use stereo RCA phono cables to connect analog audio components. These cables are typically red and white, and you should connect the red plugs to R (right) terminals and white plugs to L (left) terminals.

Analog audio cables

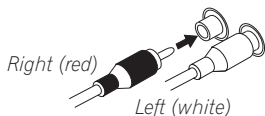

Digital audio cables

Commercially available coaxial digital audio cables or optical cables should be used to connect digital components to this receiver.¹

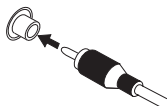

Coaxial digital audio cable

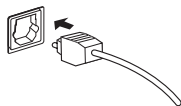

Optical cable

Video cables

Standard RCA video cables

These cables are the most common type of video connection and should be used to connect to the composite video terminals. They have yellow plugs to distinguish them from cables for audio.

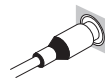

Standard RCA video cable

S-video cables

VSX-817 model only

S-video cables give you a clearer picture reproduction than standard RCA video cables by sending separate signals for the luminance and color.



S Video

Component video cables

Use component video cables to get the best possible color reproduction of your video source. The color signal of the TV is divided into the luminance (**Y**) signal and the color (**Pb** and **Pr**) signals and then output. In this way, interference between the signals is avoided.

Component video cables

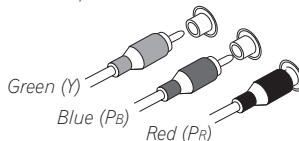

Note

- 1 • When connecting optical cables, be careful when inserting the plug not to damage the shutter protecting the optical socket.
- When storing optical cable, coil loosely. The cable may be damaged if bent around sharp corners.
- You can also use a standard RCA video cable for coaxial digital connections.

Connecting a TV and DVD player

This page shows you how to connect your DVD player and TV to the receiver.

1 Connect a coaxial digital audio output on your DVD player to the DIGITAL COAX 1 (DVD/LD) input on this receiver.

Use a coaxial digital audio cable for the connection.¹

2 Connect the composite video output and the stereo analog audio outputs² on your DVD player to the DVD/LD inputs on this receiver.

Use a standard RCA video cable³ and a stereo RCA phono cable for the connection.

- If your DVD player has multichannel analog outputs, see *Connecting the multichannel analog outputs* below for how to connect it.

3 Connect the analog audio outputs from your TV to the TV/SAT inputs on this receiver.

This will allow you to play the sound from the TV's built-in tuner. Use a stereo RCA phono cable to do this.

- If your TV has a built-in digital decoder, you can also connect an optical digital audio output from your TV to the **DIGITAL OPT 1 (CD)** input on this receiver. Use an optical cable for the connection.⁴

4 Connect the MONITOR OUT video jack on this receiver to a video input on your TV.

Use a standard RCA video cable to connect to the composite video jack.⁵

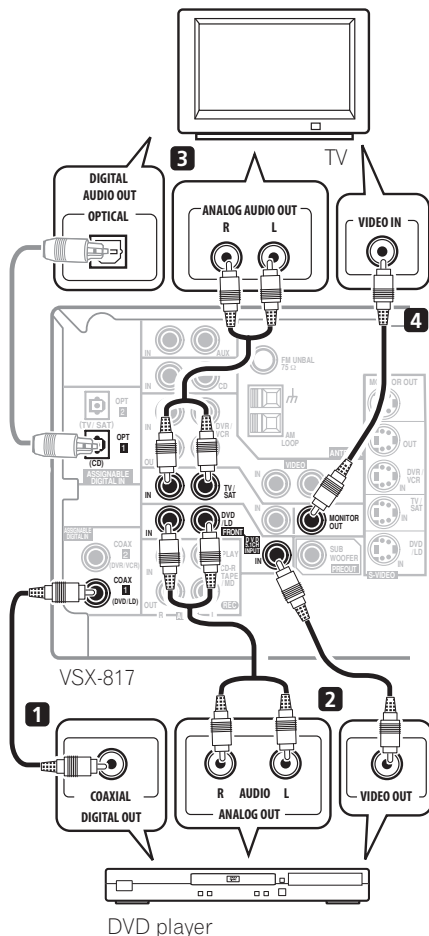

The illustration shows the VSX-817, but connections for the VSX-517 are the same.

Note

¹ If your DVD player only has an optical digital output, you can connect it to the optical input on this receiver using an optical cable. When you set up the receiver you'll need to tell the receiver which input you connected the player to (see *The Input Assign menu* on page 45).

² This connection will allow you to make analog recordings from your DVD player.

³ • VSX-817 model only – For better quality, you can also connect with S-video using the **S-VIDEO DVD/LD** jack.

⁴ If your player also has a component video output, you can connect this too. See *Using the component video jacks* on page 16. In this case, you'll need to tell the receiver which digital input you connected the TV to (see *The Input Assign menu* on page 45).

⁵ • VSX-817 model only – For better quality, you can also connect with S-video using the **S-VIDEO MONITOR OUT** jack.

• See *Using the component video jacks* on page 16 to use the component video outputs to connect this receiver to your TV.

Connecting the multichannel analog outputs

For DVD Audio and SACD playback, your DVD player may have 5.1 channel analog outputs. In this case, you can connect them to the multichannel inputs of the receiver as shown below.¹

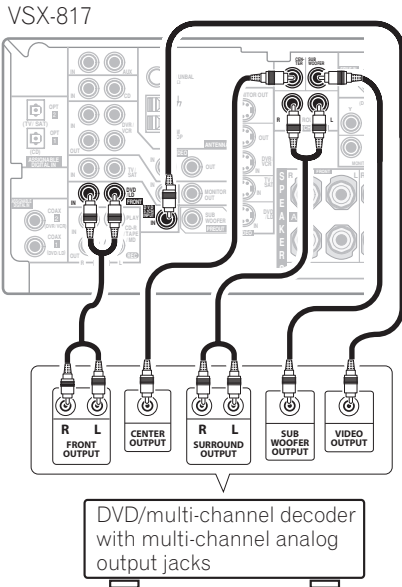

The illustration shows the VSX-817, but connections for the VSX-517 are the same.

Connecting a satellite receiver or other digital set-top box

Satellite and cable receivers, and terrestrial digital TV tuners are all examples of so-called 'set-top boxes'.

1 Connect a set of audio/video outputs on the set-top box component to the TV/SAT AUDIO and VIDEO inputs on this receiver.²

Use a stereo RCA phono cable for the audio connection and a standard RCA video cable for the video connection.³

2 If your set-top box has a digital output, connect it to a digital input on this receiver.

VSX-817 model – Use an optical cable for the connection.⁴

VSX-517 model – For example, connect to the DIGITAL OPT 1 (CD) for optical input or the DIGITAL COAX 2 (DVR/VCR) for coaxial input.⁵

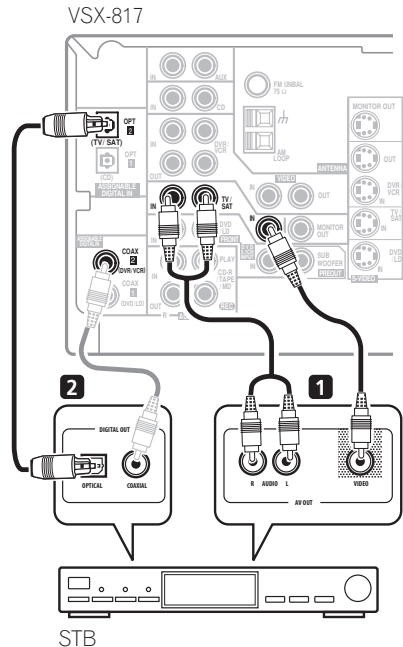

Note

¹ The multichannel input can only be used when DVD 5.1 ch is selected (see page 38).

² If you've already connected your TV to the TV/SAT inputs, simply choose another input. However, you'll need to remember which input you connected the set-top box to.

³ • VSX-817 model only – For better quality, you can also connect with S-video using the S-VIDEO TV/SAT jack.

• See *Using the component video jacks* on page 16 if your set-top box also has a component video output.

⁴ If your satellite/cable receiver doesn't have a digital audio output, omit this step. If it only has a coaxial digital output, you can connect it to one of the coaxial inputs on this receiver using a coaxial digital audio cable. When you set up the receiver you'll need to tell the receiver which input you connected the set-top box to (see *The Input Assign menu* on page 45).

⁵ In this case, you'll need to tell the receiver which digital input you connected the TV to (see *The Input Assign menu* on page 45).

The illustration shows the VSX-817, but connections for the VSX-517 are the same.

Connecting other audio components

The number and kind of connections depends on the kind of component you're connecting.¹ Follow the steps below to connect a CD-R, MD, DAT, tape recorder or other audio component.

1 If your component has a digital output, connect this to a digital input on the receiver.

The example shows an optical connection to the **DIGITAL OPT 1 (CD)** input.

2 If necessary, connect the analog audio outputs of the component to a set of spare audio inputs on this receiver.

You'll need to make this connection for components without a digital output, or if you want to record from a digital component. Use a stereo RCA phono cable as shown.

3 If you're connecting a recorder, connect the analog audio outputs (REC) to the analog audio inputs on the recorder.

The example shows an analog connection to the **CD-R/TAPE/MD** analog output jack using a stereo RCA phono cable.

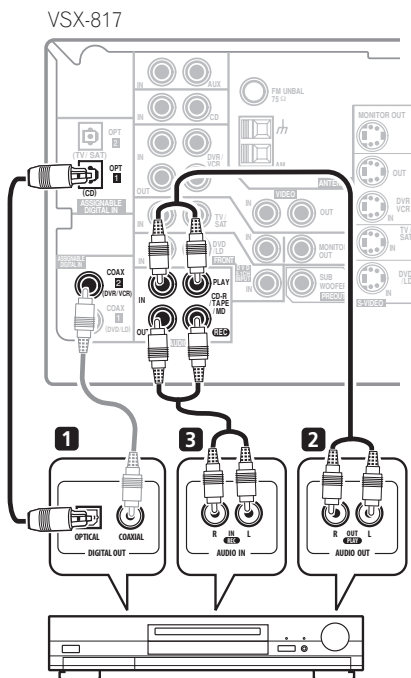

CD-R, MD, DAT, Tape recorder, etc.

The illustration shows the VSX-817, but connections for the VSX-517 are the same.

About the WMA9 Pro decoder

This unit has an on-board Windows Media[®] Audio 9 Professional (WMA9 Pro) decoder, so it is possible to playback WMA9 Pro-encoded audio using a coaxial or optical digital connection when connected to a WMA9 Pro-compatible player. However, the connected DVD player, set-top box, etc. must be able to output WMA9 Pro format audio signals through a coaxial or optical digital output.



Note

¹ Note that you must connect digital components to analog audio jacks if you want to record to/from digital components (like an MD) to/from analog components.

Windows Media[®], and the Windows logo are trademarks, or registered trademarks of Microsoft Corporation in the United States and/or other countries.

Connecting other video components

This receiver has audio/video inputs and outputs suitable for connecting analog or digital video recorders, including VCRs, DVD-recorders and HDD recorders.

1 Connect a set of audio/video outputs on the recorder to the DVR/VCR AUDIO and VIDEO inputs on this receiver.

Use a stereo RCA phono cable for the audio connection and a standard RCA video cable for the video connection.¹

2 Connect a set of audio/video inputs on the recorder to the DVR/VCR AUDIO and VIDEO outputs on this receiver.

Use a stereo RCA phono cable for the audio connection and a standard RCA video cable for the video connection.²

3 If your video component has a digital audio output, connect it to a digital input on this receiver.

The example shows a recorder connected to the **DIGITAL COAX 2 (DVR/VCR)** input.³

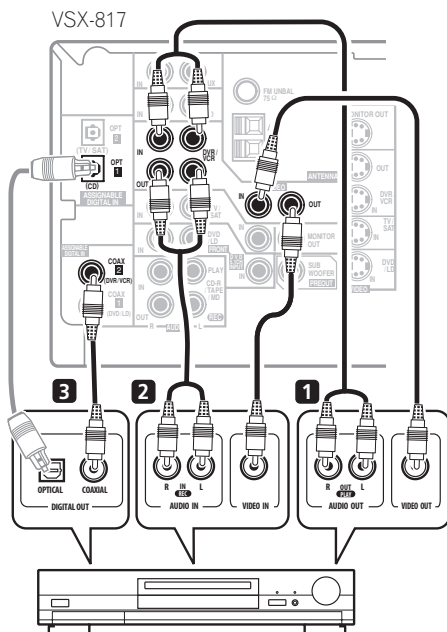

DVR, VCR, LD player, etc.

The illustration shows the VSX-817, but connections for the VSX-517 are the same.

Using the component video jacks

Component video should deliver superior picture quality when compared to composite video. A further advantage (if your source and TV are both compatible) is progressive-scan video, which delivers a very stable, flicker-free picture. See the manuals that came with your TV and source component to check whether they are progressive-scan video compatible.

Note

- 1 • *VSX-817 model only* – For better quality, you can also connect with S-video using the **S-VIDEO DVR/VCR IN** jack.
 - If your video component also has a component video output, you can connect this too. See *Using the component video jacks* on page 16 for more on this.
- 2 *VSX-817 model only* – For better quality, you can also connect with S-video using the **S-VIDEO DVR/VCR OUT** jack.
- 3 If your video component doesn't have a digital audio output, omit this step. If it only has an optical digital output, you can connect it to the optical input on this receiver using an optical cable. When you set up the receiver you'll need to tell the receiver which input you connected the component to (see *The Input Assign menu* on page 45).

Important

- If you connect any source component to the receiver using a component video input, you must also have your TV connected to this receiver's **COMPONENT VIDEO MONITOR OUT** jacks.

1 Connect the component video outputs of your source to a set of component video inputs on this receiver.

Use a three-way component video cable.

2 If necessary, assign the component video inputs to the input source you've connected.

This only needs to be done if you didn't connect according to the following defaults:

- **COMP 1** – DVD
- **COMP 2** – TV
- **COMP 3** – DVR

See *Assigning the component video inputs* on page 45.

3 Connect the COMPONENT VIDEO MONITOR OUT jacks on this receiver to the component video inputs on your TV or monitor.

Use a three-way component video cable.

Connecting to the front panel video terminal

VSX-817 model only

Front video connections are accessed via the front panel using the **VIDEO** button. Press **VIDEO** and select **VIDEO** input. There are standard audio/video jacks. Hook them up the same way you made the rear panel connections.

- Push down on the **PUSH OPEN** tab to access the front audio/video connection.

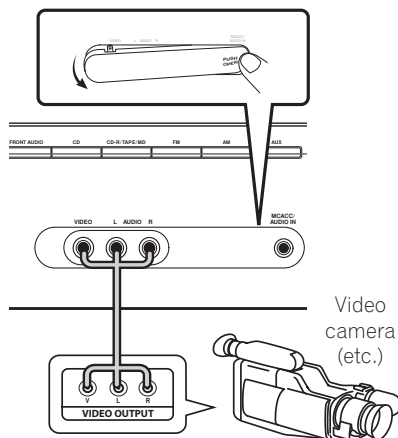

Connecting to the front panel audio mini jack

VSX-817 model only

Front audio connections are accessed via the front panel using the **FRONT AUDIO** button. Press **FRONT AUDIO** and select **F.AUDIO** input. Use a stereo mini-jack cable to connect a digital audio player.

- Push down on the **PUSH OPEN** tab to access the front audio/video connection.

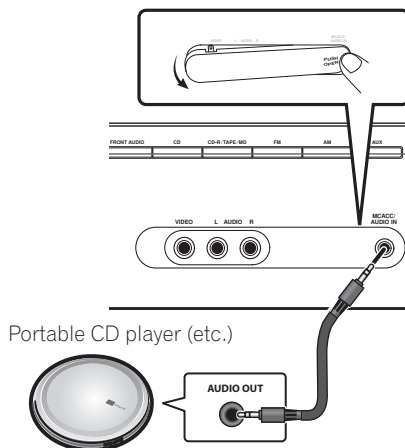

Connecting antennas

Connect the AM loop antenna and the FM wire antenna as shown below. To improve reception and sound quality, connect external antennas (see *Using external antennas* below).

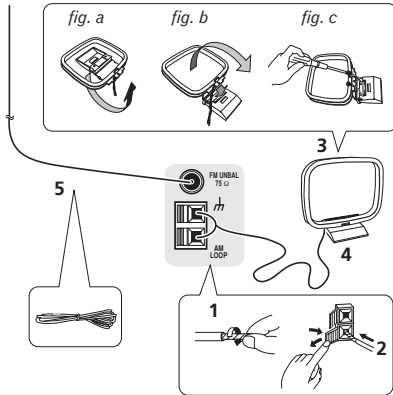

1 Pull off the protective shields of both AM antenna wires.

2 Push open the tabs, then insert one wire fully into each terminal, then release the tabs to secure the AM antenna wires.

3 Fix the AM loop antenna to the attached stand.

To fix the stand to the antenna, bend in the direction indicated by the arrow (*fig. a*) then clip the loop onto the stand (*fig. b*).

- If you plan to mount the AM antenna to a wall or other surface, secure the stand with screws (*fig. c*) before clipping the loop to the stand. Make sure the reception is clear.

4 Place the AM antenna on a flat surface and in a direction giving the best reception.

5 Connect the FM wire antenna in the same way as the AM loop antenna.

For best results, extend the FM antenna fully and fix to a wall or door frame. Don't drape loosely or leave coiled up.

Using external antennas

To improve FM reception

Connect an external FM antenna as shown below.

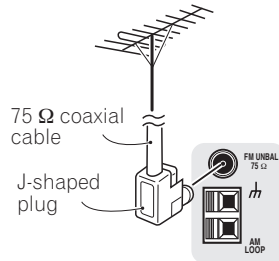

To improve AM reception

Connect a 5 m to 6 m length of vinyl-coated wire to the AM antenna terminal without disconnecting the supplied AM loop antenna.

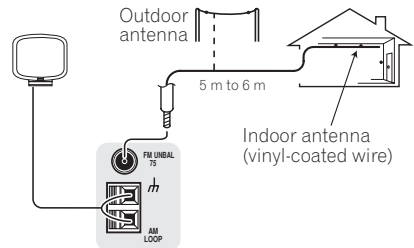

For the best possible reception, suspend horizontally outdoors.

Connecting the speakers

A complete speaker setup is shown below, but everyone's home setup will vary. Simply connect the speakers you have in the manner shown below. The receiver will work with just two stereo speakers (the front speakers in the diagram) but using at least three (*VSX-517 model*) / five (*VSX-817 model*) speakers is recommended, and a complete setup is best for surround sound. If you're not using a subwoofer, change the front speaker setting (see *Speaker setting* on page 43) to **LARGE**.

Make sure you connect the speaker on the right to the right terminal and the speaker on the left to the left terminal. Also make sure the positive and negative (+/-) terminals on the receiver match those on the speakers. You can use speakers with a nominal impedance between 6 Ω to 16 Ω (please see *Switching the speaker impedance* on page 60 if you plan to use speakers with an impedance of less than 8 Ω).

Be sure to complete all connections before connecting this unit to the AC power source.

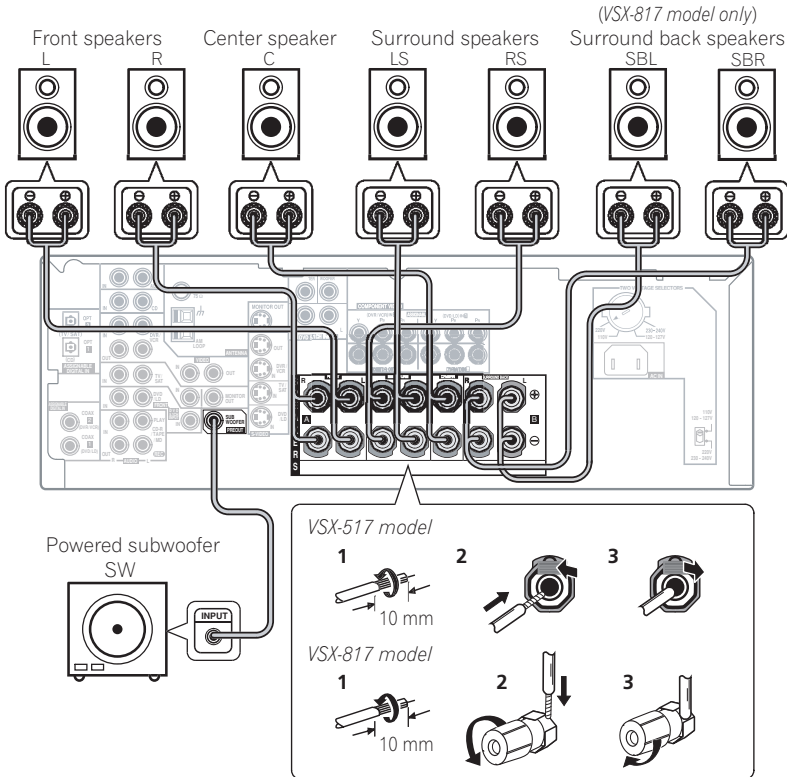

The illustration shows the VSX-817, but connections for the VSX-517 are the same.

V SX-517 model

- 1 **Twist exposed wire strands together.**
- 2 **Push open the tabs and insert exposed wire.**
- 3 **Release the tabs.**

V SX-817 model

- 1 **Twist exposed wire strands together.**
- 2 **Loosen terminal and insert exposed wire.**
- 3 **Tighten terminal.**

Speaker terminals

Make sure that all the bare speaker wire is twisted together and inserted fully into the speaker terminal. If any of the bare speaker wire is touching the back panel when you switch the unit on, the power may cut off as a safety measure. Use good quality speaker wire to connect the speakers to the receiver.



Caution

- These speaker terminals carry **HAZARDOUS LIVE voltage**. To prevent the risk of electric shock when connecting or disconnecting the speaker cables, disconnect the power cord before touching any uninsulated parts.

Hints on speaker placement

Speakers are usually designed with a particular placement in mind. Some are designed to be floorstanding, while others should be placed on stands to sound their best. Some should be placed near a wall; others should be placed away from walls. We have provided a few tips on getting the best sound from your speakers (following), but you should also follow the guidelines on placement that the speaker manufacturer provided with your particular speakers to get the most out of them.

- Place the front left and right speakers at equal distances from the TV.

- When placing speakers near the TV, we recommend using magnetically shielded speakers to prevent possible interference, such as discoloration of the picture when the TV is switched on. If you do not have magnetically shielded speakers and notice discoloration of the TV picture, move the speakers farther away from the TV.
- Place the center speaker above or below the TV so that the sound of the center channel is localized at the TV screen.
- If possible, place the surround speakers slightly above ear level.
- Try not to place the surround speakers further away from the listening position than the front and center speakers. Doing so can weaken the surround sound effect.
- To achieve the best possible surround sound, install your speakers as shown below. Be sure all speakers are installed securely to prevent accidents and improve sound quality.



Caution

- If you choose to install the center speaker on top of the TV, be sure to secure it with putty, or by other suitable means, to reduce the risk of damage or injury resulting from the speaker falling from the TV in the event of external shocks such as earthquakes.
- Make sure no exposed speaker wire is touching the rear panel, this may cause the receiver to turn off automatically.

Speaker placement diagrams

The following illustrations show 7.1 channel speaker setups.¹

3-D view of 7.1 channel speaker setup

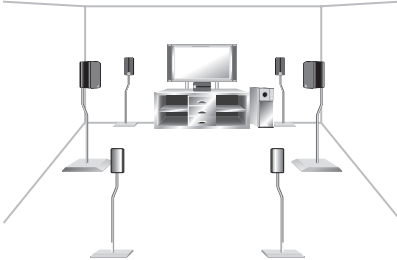

Overhead view of speaker setup

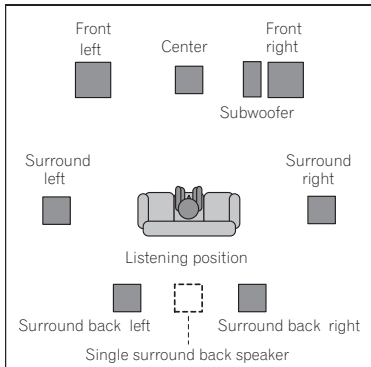

The diagrams below show suggested surround and surround back speaker orientation. The first diagram (*fig. A*) shows orientation with one surround back speaker (or none) connected. The second (*fig. B*) shows orientation with two surround back speakers connected.

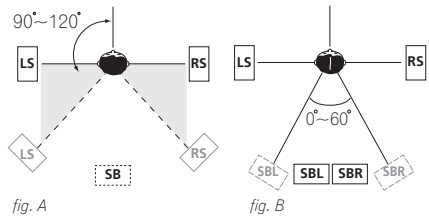

Note

¹ VSX-517 model only – Follow the speaker placement diagrams, disregarding the surround back speakers.

Chapter 4: Controls and displays

Front panel

Illustration shows the VSX-817 model

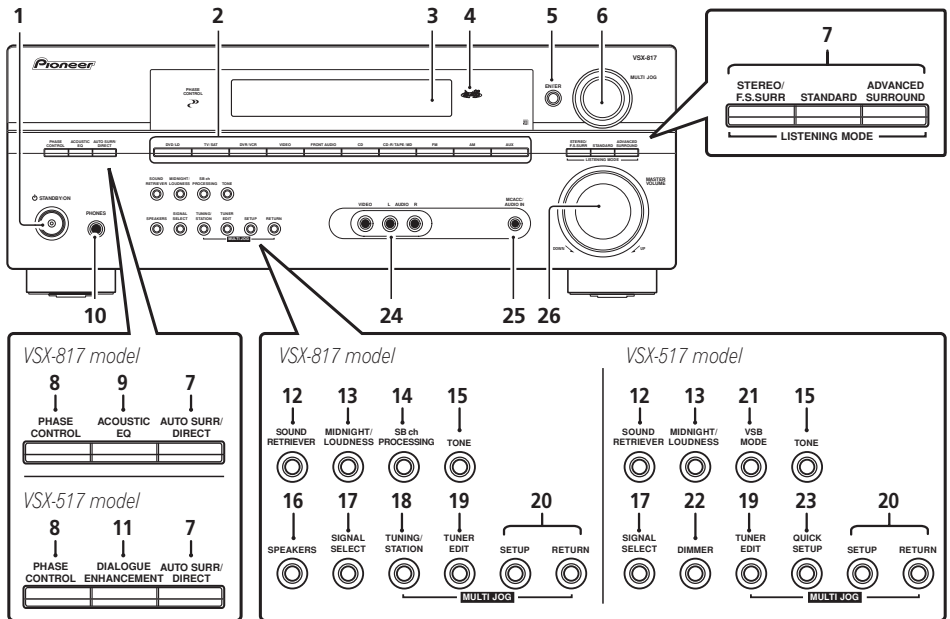

1 **STANDBY/ON**

2 **Input select buttons**

Selects an input source.

3 **Character display**

See *Display* on page 24.

4 **MCACC indicator** (VSX-817 model only)

Lights when Acoustic Calibration EQ (page 34) is on (Acoustic Calibration EQ is automatically set to **ALL CH ADJUST** after the Auto MCACC Setup (page 10) or EQ Auto Setup (page 41)).

5 **ENTER**

6 **MULTI JOG dial**

The **MULTI JOG** dial performs a number of tasks. Use it to select options after pressing the designated **MULTI JOG** buttons.

7 **LISTENING MODE buttons**

STEREO/F.S.SURR

Switches between stereo playback (page 33) and Front Stage Surround Advance modes (page 33).

STANDARD

Press for Standard decoding and to switch between the various **Pro Logic II** options *(VSX-817 model only)* – **Pro Logic IIx** and Neo:6 options (page 31).

ADVANCED SURROUND

Switches between the various surround modes (page 32).

AUTO SURR/DIRECT

Switches between Auto surround mode *(Auto playback on page 31)* and Stream Direct playback. Stream Direct playback bypasses the tone controls for the most accurate reproduction of a source (page 34).

8 PHASE CONTROL

Press to switch on/off Phase Control (page 36).

9 ACOUSTIC EQ

Press to select an Acoustic Calibration EQ setting (page 34).

10 PHONES jack

Use to connect headphones (when connected, there is no sound output from the speakers).

11 DIALOGUE ENHANCEMENT

Use to make dialog stand out when watching TV or a movie (page 37).

12 SOUND RETRIEVER

Press to restore CD quality sound to compressed audio sources (page 37).

13 MIDNIGHT/LOUDNESS

Switches to Midnight or Loudness listening (page 37).

14 SB ch PROCESSING

Selects the surround back channel mode (page 35) or virtual surround back mode (page 35).

15 TONE

Press this button to access the bass and treble controls, which you can then adjust with the **MULTI JOG** dial (page 37).

16 SPEAKERS

Use to change the speaker system (page 56) and the impedance setting (page 60).

17 SIGNAL SELECT

Selects an input signal (page 34).

18 TUNING / STATION

Selects the frequency (page 47) and station presets (page 47) when using the tuner.

19 TUNER EDIT

Memorizes/names stations for recall (page 47).

20 System Setup menu controls

SETUP

Use with the **MULTI JOG** dial to access the System Setup menu (page 39).

RETURN

Confirms and exits the current menu.

21 VSB MODE

Press to switch on/off Virtual Surround Back (VSB) mode (page 35).

22 DIMMER

Dims or brightens the display.

23 QUICK SETUP

See *Using the Quick Setup* on page 9.

24 VIDEO INPUT *(VSX-817 model only)*

See *Connecting to the front panel video terminal* on page 17.

25 MCACC/AUDIO IN jack *(VSX-817 model only)*

Use to connect a microphone when performing Auto MCACC setup, or connect an auxiliary component using a stereo mini-jack cable (page 17).

26 MASTER VOLUME

Display

Illustration shows the VSX-817 model

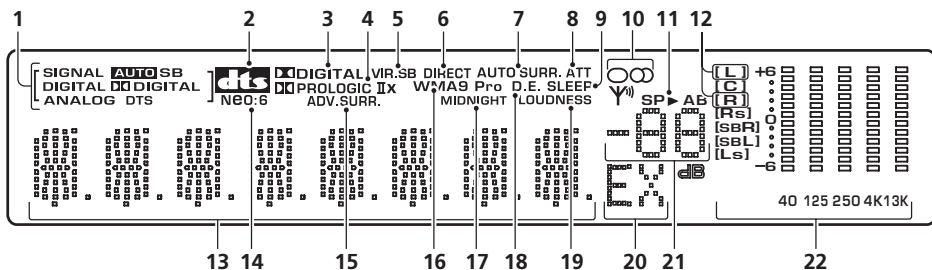

1 SIGNAL SELECT indicators

Lights to indicate the type of input signal assigned for the current component:

AUTO

Lights when **AUTO** signal select is on.

SB (VSX-817 model only)

Depending on the source, this lights when a signal with surround back channel encoding is detected.

DIGITAL

Lights when a digital audio signal is detected.

DTS

Lights when a source with DTS encoded audio signals is detected.

DIGITAL

Lights when a Dolby Digital encoded signal is detected.

ANALOG

Lights when an analog signal is detected.

2 DTS

Lights to indicate decoding of a DTS multichannel signal.

3 DIGITAL

Lights to indicate decoding of a Dolby Digital multichannel signal.

4 PRO LOGIC IIx (VSX-817 model only) / PRO LOGIC II

PRO LOGIC IIx lights to indicate Pro Logic IIx decoding. PRO LOGIC II lights to indicate Pro Logic II decoding (see *Listening in surround sound* on page 31 for more on this).

5 VIR.SB

Lights during Virtual surround back processing (page 35).

6 DIRECT

Lights when source Stream Direct playback is in use. Stream Direct playback bypasses the tone controls for the most accurate reproduction of a source.

7 AUTO SURR.

Lights when the Auto Surround feature is switched on (see *Auto playback* on page 31).

8 ATT

Lights when **ANALOG ATT** is used to attenuate (reduce) the level of the analog input signal.

9 SLEEP

Lights when the receiver is in sleep mode.

10 Tuner indicators

○ / MONO

Lights when the mono mode is set using the **MPX** button.

∞ / STEREO

Lights when a stereo FM broadcast is being received in auto stereo mode.

Y^{FM} / TUNED

Lights when a broadcast is being received.

11 Speaker indicator

VSX-817 model – Lights to indicate the current speaker system **A** and/or **B** (page 56).

VSX-517 model – Shows if the speaker system is on or not. **SP▶A** means the speakers are switched on. **SP▶** means the headphones are connected.

12 Sound Retriever indicators

Light when the Sound Retriever is switched on (page 37).

13 Character display

14 Neo:6 (*VSX-817 model only*)

Lights to indicate Neo:6 processing.

15 ADV.SURR. (Advanced Surround)

Lights when one of the Advanced Surround modes has been selected.

16 WMA9 Pro

Lights to indicate decoding of a WMA9 Pro signal.

17 MIDNIGHT

Lights during Midnight listening (page 37).

18 D.E.

Lights when Dialog Enhancement is switched on (page 37).

19 LOUDNESS

Lights during Loudness listening (page 37).

20 EX (*VSX-817 model only*)

Lights when a Dolby Digital Surround EX encoded signal is detected.

21 Master volume level

22 MCACC channel EQ indicators

(*VSX-817 model only*)

These indicators show the EQ balance for each channel in *Checking your Acoustic Calibration EQ settings* on page 43.

Remote control (VSX-817)

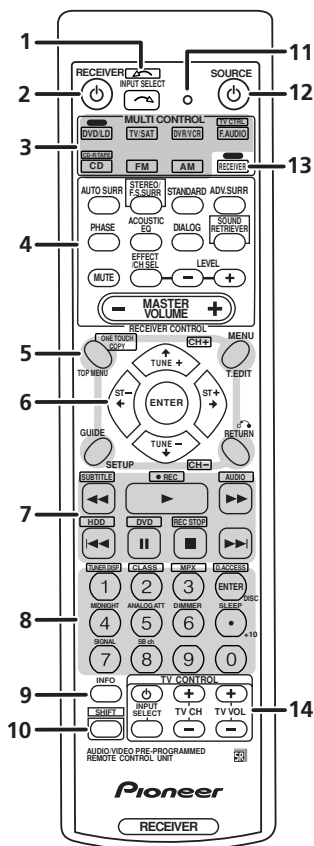

1 INPUT SELECT

Use to select the input source (use **SHIFT** for **INPUT SELECT**).

2 RECEIVER

This switches between standby and on for this receiver.

3 MULTI CONTROL buttons

Press to select control of other components (see *Controlling the rest of your system* on page 50).

4 RECEIVER CONTROL buttons

AUTO SURR

Switches between Auto surround mode (*Auto playback* on page 31) and Stream Direct playback. Stream Direct playback bypasses the tone controls for the most accurate reproduction of a source (page 34).

STEREO/F.S.SURR

Switches between stereo playback (page 33) and Front Stage Surround Advance modes (page 33).

STANDARD

Press for Standard decoding and to switch between the **PRO** Pro Logic IIx and Neo:6 options (page 31).

ADV.SURR

Switches between the various surround modes (page 32).

PHASE

Press to switch on/off Phase Control (page 36).

ACOUSTIC EQ

Press to select an Acoustic Calibration EQ setting (page 34).

DIALOG

Use to make dialog stand out when watching TV or a movie (page 37).

SOUND RETRIEVER

Press to restore CD quality sound to compressed audio sources (page 37).

MUTE

Mutes/unmutes the sound.

EFFECT/CH SEL

Press repeatedly to select a channel, then use **LEVEL +/-** to adjust the level (page 44). Also adjusts the level of the Advanced Surround effects as well as Dolby Pro Logic IIx Music and Neo:6 Music parameters (page 32). You can then use the **LEVEL +/-** buttons to make these adjustments.

LEVEL +/-

Use to adjust the Advanced Surround effect and channel levels, as well as to change Dolby Pro Logic IIx Music and Neo:6 Music parameter settings.

MASTER VOLUME +/-

Use to set the listening volume.

5 SYSTEM SETUP and Component control buttons

The following button controls can be accessed after you have selected the corresponding **MULTI CONTROL** button (**DVD/LD, TV/SAT, RECEIVER**, etc.)

TOP MENU

Displays the disc 'top' menu of a DVD.

ONE TOUCH COPY*

Copies the currently playing title from DVD to HDD or vice-versa.

GUIDE

Displays the guides on a digital TV.

SETUP

Use to access the System Setup menu (see page 39).

MENU

Displays the disc menu of DVD-Video discs.

T.EDIT

Press to memorize and name a station for recall (page 47).

RETURN

Press to confirm and exit the current menu (also use to return to the previous menu with DVDs or to select closed captioning with DTV).

6 ←→↓↑ (TUNE/ST +/-) /ENTER

Use the arrow buttons when setting up your surround sound system (see page 39). Also used to control DVD menus/options and for deck 1 of a double cassette deck player. Use the **TUNE +/-** buttons to find radio frequencies and use **ST +/-** to find preset stations (page 47). Use the **(SHIFT+) CH +/-** buttons to select channels.

7 Component control buttons

The main buttons (▶, ■, etc.) are used to control a component after you have selected it using the **MULTI CONTROL** buttons.

The controls above these buttons can be accessed after you have selected the corresponding **MULTI CONTROL** button (for example **DVD/LD**, **DVR/VCR** or **TV/SAT** (when connected to a DTV)).

SUBTITLE*

Displays/changes the subtitles included in multilingual DVD-Video discs.

●REC*

Start recording.

AUDIO*

Changes the audio language or channel on DVD discs.

HDD/DVD*

These buttons switch between the hard disk and DVD controls for DVD/HDD recorders.

REC STOP*

Stops recording.

8 Number buttons/other component and receiver controls

Use the number buttons to directly select a radio frequency (page 47) or the tracks on a CD, DVD, etc. There are other buttons that can be accessed after the **RECEIVER** is pressed (For example, **MIDNIGHT**, etc),

DISC (ENTER) can be used to enter commands for TV or DTV, and can also be used to select a disc in a multi-CD player.

TUNER DISP*

Switches between named station presets and radio frequencies (page 48).

CLASS*

Switches between the three banks (classes) of radio station presets (page 47).

MPX*

Switches between stereo and mono reception of FM broadcasts. If the signal is weak then switching to mono will improve the sound quality (page 47).

D. ACCESS*

After pressing, you can access a radio station directly using the number buttons (page 47).

MIDNIGHT

Switches to Midnight or Loudness listening (page 37).

ANALOG ATT

Attenuates (lowers) the level of an analog input signal to prevent distortion.

DIMMER

Dims or brightens the display.

SLEEP

Press to change the amount of time before the receiver switches into standby (**30 min – 60 min – 90 min – Off**). You can check the remaining sleep time at any time by pressing **SLEEP** once.

SIGNAL

Selects an input signal (page 34).

SB ch

Selects the surround back channel mode (page 35) or virtual surround back mode (page 35).

9 INFO

Use to bring up information screens on a digital TV.

10 SHIFT

Press to access the 'boxed' commands (above the buttons) on the remote. These buttons are marked with an asterisk (*) in this section.

11 Remote control LED

Lights when a command is sent from the remote control.

12 SOURCE

Press to turn on/off other components connected to the receiver (see page 50 for more on this).

13 RECEIVER

Switches the remote to control the receiver (used to select the green commands above the number buttons (**SETUP**, etc)). Also use this button to set up surround sound (page 9, page 39).

14 TV CONTROL buttons

These buttons are dedicated to control the TV assigned to the **TV CTRL** button. Thus if you only have one TV to hook up to this system assign it to the **TV CTRL MULTI CONTROL** button. If you have two TVs, assign the main TV to the **TV CTRL** button (see page 50 for more on this).



Use to turn on/off the power of the TV.

INPUT SELECT

Use to select the TV input signal.

TV CH +/-

Use to select channels.

TV VOL +/-

Use to adjust the volume on your TV.

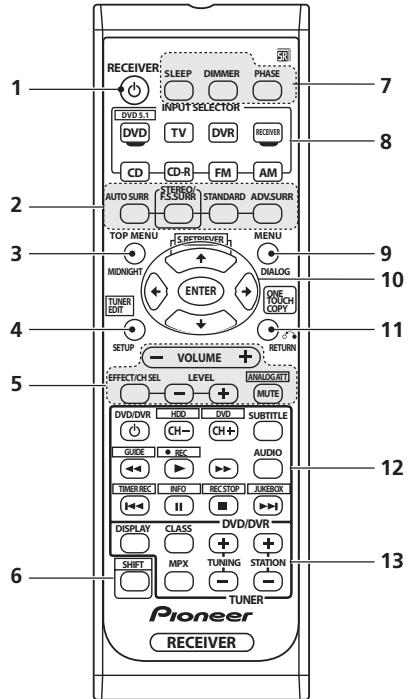
Remote control (VSX-517)**1 RECEIVER**

Switches the receiver between standby and on.

2 Listening mode buttons**AUTO SURR**

Switches between Auto surround mode (*Auto playback* on page 31) and Stream Direct playback. Stream Direct playback bypasses the tone controls for the most accurate reproduction of a source (page 34).

STANDARD

Press for Standard decoding and to switch between  Pro Logic II options.

STEREO/F.S.SURR

Switches between stereo playback (page 33) and Front Stage Surround Advance modes (page 33).

ADV.SURR

Switches between the various surround modes (page 32).

3 TOP MENU

Displays the disc 'top' menu of a DVD.

MIDNIGHT/LOUDNESS

Switches to Midnight or Loudness listening (page 37).

4 TUNER EDIT*

Memorizes/names stations for recall (page 47).

SETUP

Press to access the System Setup menu (page 39). Also functions as the **SETUP** button for DVD/DVR units.

5 RECEIVER CONTROL buttons

VOLUME +/-

Use to set the listening volume.

EFFECT/CH SEL

Press repeatedly to select a channel, then use **LEVEL +/-** to adjust the level. Also adjusts the level of the Advanced Surround effects as well as Dolby Pro Logic II Music parameters (page 32). You can then use the **LEVEL +/-** buttons to make these adjustments.

LEVEL +/-

Use to adjust the effect and channel levels.

MUTE

Mutes/unmutes the sound.

ANALOG ATT*

Attenuates (lowers) the level of an analog input signal to prevent distortion.

6 SHIFT

Press to access the 'boxed' commands (above the buttons) on the remote. These buttons are marked with an asterisk (*) in this section.

7 SLEEP

Press to change the amount of time before the receiver switches into standby (**30 min – 60 min – 90 min – Off**). You can check the remaining sleep time at any time by pressing **SLEEP** once.

DIMMER

Dims or brightens the display.

PHASE

Press to switch on/off Phase Control (page 36).

8 INPUT SELECTOR buttons

Press to select an input source.

DVD/DVR

Press to use the remote DVD/DVR controls.

RECEIVER

Use to switch to the receiver controls on the remote control. Use when setting up surround sound for the receiver (page 39).

9 MENU

Displays the disc menu of DVD-Video discs. It also displays TV menus.

DIALOG

Use to make dialog stand out when watching TV or a movie (page 37).

10 /ENTER

Use the arrow buttons when setting up your surround sound system (page 39). Also used for DVD menus.

(S.RETRIEVER)*

Press to restore CD quality sound to compressed audio sources (page 37).

11 RETURN







Confirm and exit the current menu screen.

ONE TOUCH COPY*

Copies the currently playing title from DVD to HDD or vice-versa.

12 DVD/DVR control buttons

Use these buttons to control a Pioneer DVD player or recorder connected to your system (press **SHIFT** to access the commands bordered by a rectangle).

Button	What it does
DVD/ DVR 	Turns DVD power on/off.
CH +/-	Switches channels.
SUBTITLE	Displays/changes the subtitles on multilingual DVD-Video discs.
AUDIO	Changes audio language or channel.
	Starts/resumes normal playback.
II	Pauses/unpauses.
	Stops playback.
	Press to start fast reverse/forward scanning.
	Skips to the start of the current track or chapter, then previous tracks/chapters.
	Skips to the next track or chapter.
HDD/ DVD *	Switch between the hard disk and DVD controls for DVD/HDD recorders.
GUIDE *	Displays the guides on a DVD/DVR.
	Starts recording.
TIMER REC *	Accesses the timerrecording menu.
INFO *	Displays additional EPG information.
REC STOP *	Stops recording.
JUKEBOX *	Switches to the Jukebox feature.

13 TUNER controls

The **TUNING +/-** buttons can be used to find radio frequencies (page 47) and the **STATION +/-** buttons can be used to select preset radio stations (page 48).

DISPLAY

Switch the display between station preset name and frequency (see tip on page 47).

CLASS

Switches between the three banks (classes) of station presets (page 47).

MPX

Use to switch between auto stereo and mono reception of FM broadcasts. If the signal is weak then switching to mono will improve the sound quality (page 47).

Chapter 5:

Listening to your system

 **Important**

- Certain features explained in this section will not be possible depending on the source (for example, PCM 88.2 kHz / 96 kHz, DTS 96 kHz (24 bit) or WMA9 Pro sources).

Auto playback

The simplest, most direct listening option is the Auto Surround feature. With this, the receiver automatically detects what kind of source you're playing and selects multichannel or stereo playback as necessary.¹

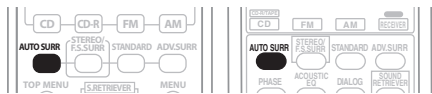

Above: VSX-517 (left) and VSX-817 (right)

- **While listening to a source, press **AUTO SURR**² for auto playback of a source.**

Press repeatedly until **AUTOSURR** shows briefly in the display (it will then show the decoding or playback format). Check the digital format indicators in the display to see how the source is being processed.

Listening in surround sound

Using this receiver, you can listen to any source in surround sound. However, the options available will depend on your speaker setup and the type of source you're listening to.

 **Note**

¹ • Stereo surround (matrix) formats are decoded accordingly using **Pro Logic II MOVIE** (VSX-517)/**Pro Logic IIx MOVIE** or **Neo:6 CINEMA** (VSX-817) (see *Listening in surround sound* below for more on these decoding formats).

• The Auto Surround feature is canceled if you connect headphones or select the multichannel analog inputs.

² For more options using this button, see *Using Stream Direct* on page 34.

³ VSX-817 model only – If surround back channel processing (page 35) is switched to **OFF**, or the surround back speaker is set to **NO** (page 39), **Pro Logic IIx** becomes **Pro Logic II** (5.1 channel sound).

⁴ When listening to 2-channel sources in Dolby Pro Logic IIx Music/Dolby Pro Logic II Music mode, there are three further parameters you can adjust: Center Width, Dimension, and Panorama. See *Setting the effect options* below to adjust them.

VSX-817 only – If you connected surround back speaker, see also *Using surround back channel processing* on page 35.



Above: VSX-517 (left) and VSX-817 (right)

- **While listening to a source, press **STANDARD**.**

If the source is Dolby Digital, DTS, or Dolby Surround encoded, the proper decoding format will automatically be selected and shows in the display.³

With two channel sources, press **STANDARD** repeatedly to select from:

- **Pro Logic II MOVIE** – Up to 5.1 channel sound, especially suited to movie sources
- **Pro Logic II MUSIC**⁴ – Up to 5.1 channel sound, especially suited to music sources
- **Pro Logic II GAME** – Up to 5.1 channel sound, especially suited for video games
- **PRO LOGIC** – 4.1 channel surround sound

VSX-817 model only:

- **Pro Logic IIx MOVIE** – Up to 7.1 channel sound, especially suited to movie sources
- **Pro Logic IIx MUSIC** – Up to 7.1 channel sound, especially suited to music sources
- **Pro Logic IIx GAME** – Up to 7.1 channel sound, especially suited for video games

- **Neo:6 CINEMA** – 6.1 channel sound, especially suited to movie sources
- **Neo:6 MUSIC** – 6.1 channel sound, especially suited to music sources

VSX-817 model only – With multichannel sources, if you have connected surround back speaker(s) and have selected **SB ON**, you can select (according to format):

- **Pro Logic IIx MOVIE** – See above
- **Pro Logic IIx MUSIC** – See above
- **Dolby Digital EX** – Creates surround back channel sound for 5.1 channel sources and provides pure decoding for 6.1 channel sources (like Dolby Digital Surround EX)
- **DTS-ES** – Allows you to hear 6.1 channel playback with DTS encoded sources

Using the Advanced surround effects

The Advanced surround feature creates a variety of surround effects. Try different modes with various soundtracks to see which you like.¹



Above: VSX-517 (left) and VSX-817 (right)

- Press '**ADV.SURR**' repeatedly to select a listening mode.
 - **ACTION** – Designed for action movies with dynamic soundtracks.
 - **DRAMA** – Designed for movies with lots of dialog.
 - **MONOFILM** – Creates surround sound from mono soundtracks.
 - **ENT. SHOW** – Suitable for musical sources.
 - **EXPANDED** – Creates an extra wide stereo field.²
 - **TV SURR.** – Provides surround sound for both mono and stereo TV sources.

- **ADV. GAME** – Suitable for video games.
- **SPORTS** – Suitable for sports programs.
- **ROCK/POP** – Creates a live concert sound for rock and/or pop music.
- **UNPLUGGED** – Suitable for acoustic music sources.
- **X-STEREO** – Gives multichannel sound to a stereo source, using all of your speakers.
- **PHONESUR.** – Creates the effect of overall surround with headphones.

Setting the effect options

When using surround effects, there are a number of settings you can adjust.

1 Press EFFECT/CH SEL repeatedly to select the setting you want to adjust.

Depending on the current status / mode of the receiver, certain options may not appear. Check the table below for notes on this.

2 Use the LEVEL +/- buttons to set it as necessary.

See the table below for the options available for each setting. The defaults, if not stated, are listed in bold.

3 Press EFFECT/CH SEL again to adjust other settings.

Setting	What it does	Options
Center Width^a (Applicable only when using a center speaker)	Spreads the center channel between the front right and left speakers, making it sound wider (higher settings) or narrower (lower settings).	0 to 7 Default: 3
Dimension^a	Adjusts the surround sound balance from front to back, making the sound more distant (minus settings), or more forward (positive settings).	-3 to +3 Default: 0

Note

- If you press **ADV.SURR** with the headphones connected, **PHONES SURROUND** will automatically be selected.
 - *VSX-817 model only* – Depending on the source and the sound mode you have selected, you may not get sound from the surround back speaker in your setup. For more on this, refer to *Using surround back channel processing* on page 35.
 - When an Advanced Surround listening mode is selected, the effect level can be adjusted using the **EFFECT** parameter in *Setting the effect options* below.
- Use with Dolby Pro Logic for a stereo surround effect (stereo field is wider than Standard modes with Dolby Digital sources).

Setting	What it does	Options
Panorama^a	Extends the front stereo image to include surround speakers for a 'wraparound' effect.	OFF ON
Center Image^b (Applicable only when using a center speaker)	Adjusts the center image to create a wider stereo effect with vocals. Adjust the effect from 0 (all center channel sent to front right and left speakers) to 10 (center channel sent to the center speaker only).	0 to 10 Default: 3
Effect	Sets the effect level for the currently selected Advanced Surround mode (each mode can be set separately).	10 to 90

a Only available with 2 ch sources in Dolby Pro Logic IIx Music (VSX-817 model only)/Dolby Pro Logic II Music mode.
 b VSX-817 model only – Only available with 2 ch sources in Neo:6 Music mode.

Listening in stereo

When you select **STEREO** you will hear the source through just the front left and right speakers (and possibly your subwoofer depending on your speaker settings). Dolby Digital and DTS multichannel sources are downmixed to stereo.



Above: VSX-517 (left) and VSX-817 (right)

• While listening to a source, press **STEREO/F.S.SURR** for stereo playback.

Press repeatedly to switch between:

- **STEREO** – The audio is heard with your surround settings and you can still use the Midnight, Loudness, and Tone functions.
- **F.S.S.FOCUS** – See *Using Front Stage Surround Advance* below for more on this.
- **F.S.S. WIDE** – See *Using Front Stage Surround Advance* below for more on this.

Using Front Stage Surround Advance

The Front Stage Surround Advance function allows you to create natural surround sound effects using just the front speakers and the subwoofer.



Above: VSX-517 (left) and VSX-817 (right)

• While listening to a source, press **STEREO/F.S.SURR** to select Front Stage Surround Advance modes.

- **STEREO** – See *Listening in stereo* above for more on this.
- **F.S.S.FOCUS** – Use to provide a rich surround sound effect directed to the center of where the front left and right speakers sound projection area converges.
- **F.S.S. WIDE** – Use to provide a surround sound effect to a wider area than **FOCUS** mode.¹

FOCUS position (Recommend)

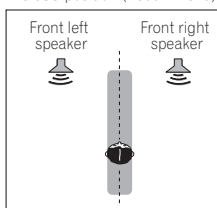

WIDE position

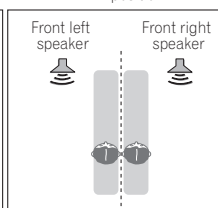

Note

- 1 • VSX-517 model – When using **F.S.S. WIDE**, a better effect can be obtained if Quick Setup is performed (see *Using the Quick Setup* on page 9).
- VSX-817 model – When using **F.S.S. WIDE**, a better effect can be obtained if Auto MCACC Setup is performed. For more on this, refer to *Automatically setting up for surround sound (MCACC)* on page 10.

Using Stream Direct

Use the Stream Direct modes when you want to hear the truest possible reproduction of a source. All unnecessary signal processing is bypassed.

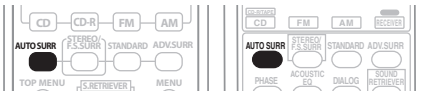

Above: VSX-517 (left) and VSX-817 (right)

- **While listening to a source, press AUTO SURR to select Stream Direct mode.**

- **AUTOSURR.** – See *Auto playback* on page 31.
- **DIRECT** – Sources are heard according to the settings made in the Surround Setup (speaker setting, channel level, speaker distance), as well as with dual mono, Center Width, Dimension and Panorama settings. You will hear sources according to the number of channels in the signal. For analog sources, only Channel Level can be set. All other digital processing can not be set.

Listening with Acoustic Calibration EQ

VSX-817 model only

- Default setting: **OFF / ALL CH** (after the Auto MCACC Setup or EQ Auto Setting)

You can listen to sources using the Acoustic Calibration Equalization set in *Automatically setting up for surround sound (MCACC)* on page 10 or *Acoustic Calibration EQ* on page 41. Refer to these pages for more on Acoustic Calibration Equalization.



- **While listening to a source, press (SHIFT +) ACOUSTIC EQ.**

Press repeatedly to select between:

- **ALL CH** – No special weighting is given to any one channel.
- **F. ALIGN** – All speakers are heard in accordance with the front speaker settings.
- **CUSTOM 1/2** – Custom settings
- **EQ OFF** – Switches Acoustic Calibration EQ off.

The MCACC indicator on the front panel lights when Acoustic Calibration EQ is active.¹

Choosing the input signal

- Default setting: **AUTO**

You need to hook up a component to both analog and digital inputs on the rear of the receiver to select between input signals.²

- **Press SIGNAL SELECT (front panel) to select the input signal corresponding to the source component.**

Each press cycles through the following:

- **AUTO** – This automatically switches to **DIGITAL** if a digital source is detected, otherwise it remains on **ANALOG**.
- **ANALOG** – Selects the analog inputs.
- **DIGITAL** – Selects the digital input.

When set to **DIGITAL** or **AUTO**, **□ DIGITAL** lights when a Dolby Digital signal is input, and **DTS** lights when a DTS signal is input.

Note

- ¹ You can't use Acoustic Calibration EQ with **DVD 5.1ch**, WMA9 Pro and it has no effect with headphones.
- ² This receiver can only playback Dolby Digital, PCM (32 kHz to 96 kHz), DTS and WMA9 Pro digital signal formats. With other digital signal formats, set to **ANALOG**.
 - You may get digital noise when a LD or CD player compatible with DTS is playing an analog signal. To prevent noise, make the proper digital connections (page 13) and set the signal input to **DIGITAL**.
 - Some DVD players don't output DTS signals. For more details, refer to the instruction manual supplied with your DVD player.

Using surround back channel processing

VSX-817 model only

- Default setting: **SB ON**

You can have the receiver automatically use 6.1 decoding for 6.1 encoded sources (for example, Dolby Digital EX or DTS-ES), or you can choose to always use 6.1 decoding (for example, with 5.1 encoded material). With 5.1 encoded sources, a surround back channel will be generated, but the material may sound better in the 5.1 format for which it was originally encoded (in which case, you can simply switch surround back processing off).¹

The table below indicates when you will hear the surround back channel (●=Sound plays through surround back speaker).

- **Press SB ch PROCESSING to select a surround back channel option.**

Each press cycles through the following:

- **SB ON** – 6.1 decoding is always used (for example, a surround back channel will be generated for 5.1 encoded material)
- **SB AUTO** – Automatically switches to 6.1 decoding for 6.1 encoded sources (for example, Dolby Digital EX or DTS-ES)
- **SB OFF** – Maximum 5.1 playback

Using Virtual Surround Back (VSB)

When you're not using surround back speaker, selecting this mode allows you to hear a virtual surround back channel through your surround speakers. You can choose to listen to sources with no surround back channel information, or if the material sounds better in the format (for example, 5.1) for which it was originally encoded, you can have the receiver only apply this effect to 6.1 encoded sources like Dolby Digital EX or DTS-ES.²

Depending on the input signal and the Listening Mode, the Virtual Surround Back mode may not be effective.

VSX-817 model only – The table indicates when you will hear the virtual surround back channel (●=Sound plays through surround speaker).

- **Press SB ch PROCESSING / VSB MODE to select a virtual surround back channel option.**

Each press cycles through the following:

- **VSB ON** – Virtual Surround Back is always used (for example, on 5.1 encoded material)
- **VSB AUTO** (*VSX-817 model only*) – Virtual Surround Back is automatically applied to 6.1 encoded sources (for example, Dolby Digital EX or DTS-ES)
- **VSB OFF** – Virtual Surround Back mode is switched off

Note

¹ You can't use the surround back channel processing with headphones, the Stereo, Front Stage Surround Advance, Stream Direct mode, or if the surround speaker is set to **NO** in *Speaker setting* on page 43 (*VSX-817 model only* – however, the surround back speaker *must* be set to **NO**).

² The Virtual Surround Back mode is not effective when using headphones, Stream Direct, Stereo, Front Stage Surround Advance mode. It is also unavailable if the surround speaker is set to **NO** in *Speaker setting* on page 43.

Type of source	SBch Processing / Virtual SB mode	Standard				Advanced surround
		Multichannel sources	Stereo sources			
			Dolby Pro Logic IIx	Dolby Pro Logic	Neo:6	
Dolby Digital EX/DTS-ES/WMA9 Pro encoded multichannel sources with 6.1ch surround	ON	●				● ^a
	AUTO	●				● ^a
Dolby Digital/DTS/WMA9 Pro encoded multichannel sources	ON	●				● ^a
	AUTO	●				● ^a
Dolby Digital/DTS/WMA9 Pro encoded stereo source; other digital stereo source	ON		●	● ^{a,b}	●	● ^a
	AUTO		● ^c		●	● ^a
Analog 2-channel (stereo) sources	ON		●	● ^b	●	●
	AUTO		● ^c		●	●

a Excluding WMA9 Pro format

b Only applicable when using the Virtual Surround Back mode.

c Not applicable when using the Virtual Surround Back mode.

Using Phase Control

This receiver's Phase Control feature uses phase correction measures to make sure your sound source arrives at the listening position in phase, preventing unwanted distortion and/or coloring of the sound (see illustration below).

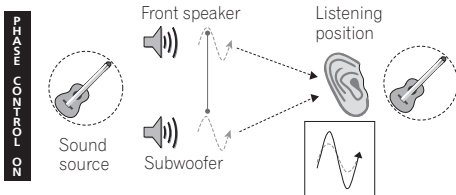
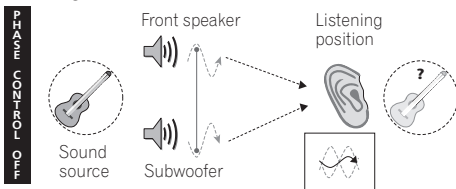

Phase Control technology provides coherent sound reproduction through the use of phase matching¹ for an optimal sound image at your listening position. The default setting is on and we recommend leaving Phase Control switched on for all sound sources.



Above: VSX-517 (left) and VSX-817 (right)

- Press **PHASE (PHASE CONTROL)** to switch on phase correction.

Note

¹ Phase matching is a very important factor in achieving proper sound reproduction. If two waveforms are 'in phase', they crest and trough together, resulting in increased amplitude, clarity and presence of the sound signal. If a crest of a wave meets a trough (as shown in the upper section of the diagram above) then the sound will be 'out of phase' and an unreliable sound image will be produced.

Using Midnight and Loudness

The Midnight listening feature allows you to hear effective surround sound of movies at low volume levels. The effect automatically adjusts according to the volume at which you're listening. The Loudness listening feature can be used to get good bass and treble from music sources at low volume levels.

- Press **MIDNIGHT (MIDNIGHT/LOUDNESS)** to switch between **MIDNIGHT, LOUDNESS, and OFF**.

Enhancing dialog

- Default setting: **OFF**

The Dialog Enhancement feature localizes dialog in the center channel to make it stand out from other background sounds in a TV or movie soundtrack.

- Press **DIALOG (DIALOGUE ENHANCEMENT)** to switch dialog enhancement on or off.

Using the tone controls

Depending on what you are listening to, you may want to adjust the bass or treble using the front panel tone control.¹

- 1 Press **TONE** to select the frequency you want to adjust.

Press to switch between **BASS** and **TREBLE**.

- 2 Use the **MULTI JOG** dial to change the amount of bass or treble as necessary.

Wait about five seconds for your changes to be input automatically.

Using the Sound Retriever

When audio data is removed during the compression process, sound quality often suffers from an uneven sound image. The Sound Retriever feature employs new DSP technology that helps bring CD quality sound back to compressed 2-channel audio by restoring sound pressure and smoothing jagged artifacts left over after compression.²

VSX-517 model –

- Press **S.RETRIEVER (SHIFT+↑) (SOUND RETRIEVER)** to switch the sound retriever on or off.

VSX-817 model –

- Press **SOUND RETRIEVER** to switch the sound retriever on or off.

Playing other sources

- 1 Turn on the power of the playback component.
- 2 Turn on the power of the receiver.
- 3 Select the source you want to playback. Use the input select buttons (**INPUT SELECTOR**).
- 4 Start playback of the component you selected in step 1.

Note

¹ The tone controls are only available when Stereo or Front Stage Surround Advance mode are selected (except when **STEREO** is selected using **AUTO SURROUND**).

² The Sound Retriever is only applicable to 2-channel sources.

Selecting the multichannel analog inputs

If you have connected a decoder or a DVD player with multichannel analog outputs to this receiver (page 14), you must select the analog multichannel inputs for surround sound.¹

VSX-517 model –

- **Press DVD 5.1 (SHIFT+DVD) on the remote control or DVD 5.1 on the front panel.**

To cancel playback from the multichannel inputs, use the **INPUT SELECTOR** buttons to select a different input signal.

VSX-817 model –

- 1 Make sure you have set the playback source to the proper output setting.**

For example, you might need to set your DVD player to output multichannel analog audio.

- 2 Press DVD/LD.**

- 3 Press SIGNAL SELECT on the front panel to select the multichannel analog inputs.**

DVD 5.1ch shows in the display and the **ANALOG** indicator lights.

Selecting the front audio inputs

VSX-817 model only

When playing back a component connected to the **MCACC/AUDIO IN** jack on the front panel, set the source to **F.AUDIO** on the receiver.

- 1 Press F.AUDIO on the remote control.**

You can also select the source by pressing **FRONT AUDIO** on the front panel.

- 2 Playback the connected component.**

Note

¹ During playback from the multichannel inputs, you can't use any of the sound features/modes and only the volume and channel levels can be set.

Chapter 6:

The System Setup menu

Using the System Setup menu

The following section shows you how to make detailed settings to specify how you're using the receiver. It also explains how to fine-tune individual speaker system settings.

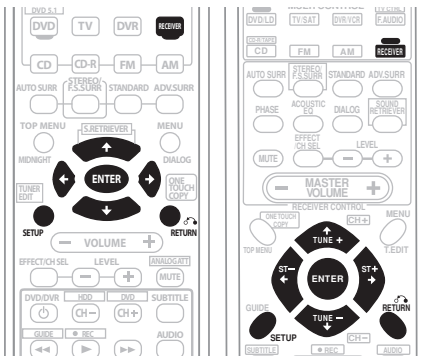

Above: VSX-517 (left) and VSX-817 (right)

- 1 Press **RECEIVER** on the remote control, then press the **SETUP** button.¹
- 2 Use **↑/↓** to select the setting you want to adjust then press **ENTER**.

- **SB.SYSTEM** (VSX-817 only) – Specify how you are using your surround back speakers (see *Surround back speaker setting* below).
- **A. MCACC** (VSX-817 only) – This is a quick and effective automatic surround setup (see *Automatically setting up for surround sound (MCACC)* on page 10).
- **M. MCACC** (VSX-817 only) – Fine tune your speaker settings and customize the Acoustic Calibration EQ (see *Manual MCACC speaker setup* on page 40).

- **SP SETUP** – Specify the size, number, distance and overall balance of the speakers you've connected (see *Manual speaker setup* on page 43).
- **IN ASSIG.** – Specify what you've connected to the digital input and component video input (see *The Input Assign menu* on page 45).
- **OTHER** – Make customized settings to reflect how you are using the receiver (see *The Other setup menu* on page 46).

Surround back speaker setting

VSX-817 model only

- Default setting: **SB NORM.**

There are several ways you can use the surround back speaker channels with this system. In addition to a normal home theater setup where they are used for the surround back speakers, they can be used for bi-amping the front speakers or as a separate speaker system in another room.

1 Select 'SB.SYSTEM' from the System Setup menu.

See *Using the System Setup menu* above if you're not already at this menu.

2 Select the surround back speaker setting.

- **SB NORM.** – Select for normal home theater use with surround back speakers in your main (speaker system A) setup.
- **SB 2ND Z** – Select to use the (surround back) B speaker terminals to listen to stereo playback in another room (see *Second Zone speaker B setup* on page 56).

Note

- 1 • VSX-817 model only – You can't use the System Setup menu when the Front Audio input is selected.
- Press **SETUP** at any time to exit the System Setup menu.

- **SB BIAMP** – Select this setting if you're bi-amping your front speakers (see *Bi-amping your front speakers* on page 57).

3 When you're finished, press RETURN.

You return to the System Setup menu.

Manual MCACC speaker setup

VSX-817 model only

You can use the settings in the Manual MCACC setup menu to make detailed adjustments when you're more familiar with the system. Before making these settings, you should have already completed *Automatically setting up for surround sound (MCACC)* on page 10.

You only need to make these settings once (unless you change the placement of your current speaker system or add new speakers).



Important

- For some of the settings below, you'll have to connect the setup microphone to the front panel and place it about ear level at your normal listening position. See *Automatically setting up for surround sound (MCACC)* on page 10 if you're unsure how to do this. Also see *Other problems during Auto MCACC* on page 11 for notes regarding high background noise levels and other possible interference.
- If you're using a subwoofer, switch it on and turn up the volume to the middle position.

1 Select 'M. MCACC' from the System Setup menu.

See *Using the System Setup menu* above if you're not already at this menu.

2 Select the setting you want to adjust.

If you're doing this for the first time, you might want to make these settings in order.

- **CH LEVEL** – Make fine adjustments to the overall balance of your speaker system (see *Fine Channel Level* below).
- **SP DISTN.** – Make precise delay settings for your speaker system (see *Fine Speaker Distance* on page 41).

The last five settings are specifically for customizing the parameters explained in *Acoustic Calibration EQ* on page 41:

- **EQ A. SET** – Measure the acoustic characteristics of your room and automatically adjust the frequency balance of your speaker system (see *Setting the Acoustic Calibration EQ automatically* on page 41).
- **EQ COPY** – Copy Acoustic Calibration EQ settings for manual adjustment (see *Copying your Acoustic Calibration EQ settings* on page 42).
- **C1 ADJ/C2 ADJ** – Make detailed manual adjustments to your custom Acoustic Calibration EQ settings (see *Setting the Acoustic Calibration EQ manually* on page 42).
- **EQ CHECK** – Check the **ALL CH, F. ALIGN** and custom settings (see *Checking your Acoustic Calibration EQ settings* on page 43).

Fine Channel Level

- Default setting: **0dB** (all channels)

You can achieve better surround sound by properly adjusting the overall balance of your speaker system. The following setting can help you make detailed adjustments that you may not achieve using the *Automatically setting up for surround sound (MCACC)* on page 10.

1 Select 'CH LEVEL' from the Manual MCACC setup menu.

You'll hear test tones from each speaker in turn. Since the left speaker is the main reference speaker, the level is fixed.

Caution

- The test tones used in the System Setup are output at high volume (the volume increases to **-18 dB** automatically).

2 Use **↑/↓** to select each channel in turn and adjust the levels (**+/- 10 dB**) as necessary.

Use **←/→** to adjust the volume of the selected speaker to match the reference speaker. When it sounds like both tones are the same volume, press **↓** (cursor down) to continue to the next channel.

- For comparison purposes, the reference speaker will change depending on which speaker you select.
- If you want to go back and adjust a channel, simply use **↑/↓** to select it.

3 When you're finished, press RETURN.

You will return to the Manual MCACC setup menu.

Fine Speaker Distance

- Default setting: **3 m** (all channels)

For proper sound depth and separation with your system, it is necessary to add a slight bit of delay to some speakers so that all sounds will arrive at the listening position at the same time. The following setting can help you make detailed adjustments that you may not achieve using the *Automatically setting up for surround sound (MCACC)* on page 10.

1 Select 'SP DISTN.' from the Manual MCACC setup menu.

2 Use **←/→** to adjust the distance of the left channel from the listening position then press ENTER.

3 Use **↑/↓** to select each channel in turn and adjust the distance as necessary.

Use **←/→** to adjust the delay of the selected speaker to match the reference speaker. The delay is measured in terms of speaker distance from **0.1** to **9.0** meters.

Listen to the reference speaker and use it to measure the target channel. From the listening position, face the two speakers with your arms outstretched pointing at each speaker.

Try to make the two tones sound as if they are arriving simultaneously at a position slightly in front of you and between your arm span.

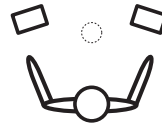

When it sounds like the delay settings are matched up, press **↓** (cursor down) to confirm and continue to the next channel.

- For comparison purposes, the reference speaker will change depending on which speaker you select.
- If you want to go back and adjust a channel, simply use **↑/↓** to select it.

4 When you're finished, press RETURN.

You will return to the Manual MCACC setup menu.

Acoustic Calibration EQ

Acoustic Calibration Equalization is a kind of room equalizer for your speakers (excluding the subwoofer). It works by measuring the acoustic characteristics of your room and neutralizing the ambient characteristics that can color the original source material. This provides a 'flat' equalization setting. If you're not satisfied with the automatic adjustment, you can also adjust these settings manually to get a frequency balance that suits your tastes.

Setting the Acoustic Calibration EQ automatically

If you have already completed *Automatically setting up for surround sound (MCACC)* on page 10, **A. CH ADJ** and **F.ALG ADJ** (below) should already be set. Therefore, if you want to adjust your settings manually, you can skip to *Setting the Acoustic Calibration EQ manually* below.

1 Select 'EQ A. SET' from the Manual MCACC setup menu.

- Make sure the microphone is connected.
- If you're using a subwoofer, it is automatically detected every time you switch on the system. Make sure it is on and the volume is at the middle position.
- See *Other problems during Auto MCACC* on page 11 for notes regarding high background noise levels and other possible interference.

2 Wait for the EQ Auto Setup to finish.

As the receiver outputs test tones, the frequency balance is adjusted automatically for the following settings:

- **A. CH** – *All Channel Adjust* is a 'flat' setting where all the speakers are set individually so no special weighting is given to any one channel.
- **F.ALG** – *Front Align Adjust* balances the overall sound so that all speakers are set in accordance with the front speaker settings (no equalization is applied to the front left and right channels).

You will return to the Acoustic Cal EQ setup menu after the Acoustic Calibration Equalization is set.

Copying your Acoustic Calibration EQ settings

If you want to manually adjust the Acoustic Calibration EQ (see *Setting the Acoustic Calibration EQ manually* below), we recommend copying the **A. CH** or the **F.ALG** settings from the **EQ A. SET** setup above (or from *Automatically setting up for surround sound (MCACC)* on page 10) to one of the custom (**C1** or **C2**) settings. Instead of just a flat EQ curve, this will give you a reference point from which to start.

1 Select 'EQ COPY' from the Manual MCACC setup menu.

2 Use ↑/↓ to select C1 or C2 then use the ←/→ buttons to select the setting you want to copy.

- You can also copy from one custom setting to another. For more on the **A. CH** and **F.ALG** settings, see *Setting the Acoustic Calibration EQ automatically* above.

3 Use ↑/↓ to select 'COPY? YES' to copy and confirm.

You can also use ←/→ to select **COPY? NO** to cancel.

Setting the Acoustic Calibration EQ manually

Before manually adjusting the Acoustic Calibration EQ, we recommend copying the **A. CH** or the **F.ALG** settings from the auto setup above (or from *Automatically setting up for surround sound (MCACC)* on page 10) to one of the custom settings. Instead of just a flat EQ curve, this will give you a reference point from which to start (see *Copying your Acoustic Calibration EQ settings* above for how to do this).

1 Select 'C1 ADJ' or 'C2 ADJ' from the Manual MCACC setup menu.

2 Use ←/→ and ENTER to select which method you want to use to adjust the overall frequency balance.

It is best to choose whichever one you copied to the custom setting in *Copying your Acoustic Calibration EQ settings* above.

- **A. CH ADJ** – All the speakers can be set independently so no special weighting is given to any one channel. When adjusting, test tones will sound for each individual channel.
- **F.ALG ADJ** – Speakers are set in accordance with the front speaker settings. The sound of the test tone will alternate between the left front (reference) speaker and the target speaker.

3 Use \leftarrow/\rightarrow to select the channel you want and adjust to your liking.

Use the \uparrow/\downarrow buttons to select the frequency and \leftarrow/\rightarrow to boost or cut the EQ. When you're finished, use the \uparrow/\downarrow buttons to select the channel display (for example **R EQ** for the right channel or **SB EQ** for the surround back channel) then \leftarrow/\rightarrow to proceed to the next channel.

- The front speakers can't be adjusted if you selected **F.ALG ADJ**.
- The **OVER!** indicator shows in the display if the frequency adjustment is too drastic and might distort. If this happens, bring the level down until **OVER!** disappears from the display.

Tip

- Changing the frequency curve of one channel too drastically will affect the overall balance. If the speaker balance seems uneven, you can raise or lower channel levels using test tones with the 'trim' band (**TRM** shows in the display). Use \uparrow/\downarrow to select **TRM** then use \leftarrow/\rightarrow to raise or lower the channel level for the current speaker.

4 When you're finished, press RETURN.

Press **RETURN** once more to go back to the Manual MCACC setup menu.

Checking your Acoustic Calibration EQ settings

After you have completed an automatic or manual Acoustic Calibration EQ adjustment, you can check the **ALL CH**, **F.ALIGN** and **CUSTOM1/2** settings in the display.

1 Select 'EQ CHECK' from the Manual MCACC setup menu.

2 Use \leftarrow/\rightarrow and ENTER to select the setting you want to check.

- It is useful to do this while a source is playing so you can compare settings.

3 Use \leftarrow/\rightarrow to select the channel you want, using \uparrow/\downarrow to check the settings.

The MCACC channel EQ indicators in the front panel display will light accordingly.

4 When you're finished, press RETURN.

You will return to the Manual MCACC setup menu.

Manual speaker setup

These settings optimize surround sound performance (if you're satisfied with the settings made in *Using the Quick Setup (VSX-517 model only)* on page 9/ *Automatically setting up for surround sound (MCACC) (VSX-817 model only)* on page 10, adjustment may not be necessary). You only need to make these settings once (unless you change the placement of your current speaker system or add new speakers).

1 Select SP SETUP from the System Setup menu.

2 Use \uparrow/\downarrow to select the setting you want to adjust then press ENTER.

- **SP SET** – Specify size / number of speakers connected (see *Speaker setting* below).
- **X.OVER** – Specify which frequencies will be sent to the subwoofer (see *Crossover network* on page 44).
- **CH LEVEL** – Adjust overall balance of your speaker system (see *Channel level* on page 44).
- **SP DISTN.** – Specify the distance of your speakers from the listening position (see *Speaker Distance* on page 45).

3 Press RETURN after making the adjustments necessary for each setting.

Speaker setting

Use this setting to specify your speaker configuration (size, number of speakers).

1 Select SP SET from the SP SETUP menu.

2 Use **↑/↓** to choose the speaker(s) that you want to set then select a speaker size.

Use **←/→** to select the size (and number) of each of the following speakers:

- **Front (F)** – Select **LARGE** if your front speakers reproduce bass frequencies effectively, or if you didn't connect a subwoofer. Select **SMALL** to send the bass frequencies to the subwoofer.¹
- **Center (C)** – Select **LARGE** if your center speaker reproduces bass frequencies effectively, or select **SMALL** to send bass frequencies to the other speakers or subwoofer. If you didn't connect a center speaker, choose **NO** (the center channel is sent to the other speakers).
- **Surround (S)** – Select **LARGE** if your surround speakers reproduce bass frequencies effectively. Select **SMALL** to send bass frequencies to the other speakers or subwoofer. If you didn't connect surround speakers choose **NO** (the sound of the surround channels is sent to the other speakers).
- **Surround Back (SB)** (*VSX-817 model only*) – Select **LARGE** if your surround back speaker reproduce bass frequencies effectively. Select **SMALL** to send bass frequencies to the other speakers or subwoofer. If you didn't connect surround back speaker choose **NO**.²
- **Subwoofer (SW)** – LFE signals and bass frequencies of channels set to **SMALL** are output from the subwoofer when **YES** is selected.³ Choose the **PLUS** setting if you want the subwoofer to output bass sound continuously or you want deeper bass (the

bass frequencies that would normally come out the front and center speakers are also routed to the subwoofer). If you did not connect a subwoofer choose **NO** (the bass is output from other speakers).

Crossover network

- Default setting: **100Hz**

This setting decides the cutoff between bass sounds playing back from the speakers selected as **LARGE**, or the subwoofer, and bass sounds playing back from those selected as **SMALL**.⁴ It also decides where the cutoff will be for bass sounds in the LFE channel.

1 Select 'X.OVER' from the SP SETUP menu.

2 Use **←/→** to choose the frequency cutoff point.

Frequencies below the cutoff point will be sent to the subwoofer (or **LARGE** speakers).

Channel level

Using these settings, you can adjust the overall balance of your speaker system.

1 Select CH LEVEL from the SP SETUP menu.

2 Use **←/→** to select a setup option.

- **T. TONE M.** – Move the test tone manually from speaker to speaker and adjust individual channel levels.
- **T. TONE A.** – Adjust channel levels as the test tone moves from speaker to speaker automatically.

3 Confirm your selected setup option.

The test tones will start after you press **ENTER**.⁵

Note

¹ If you select **SMALL** for the front speakers the subwoofer is fixed to **YES**. Also, the center, surround, and surround back speakers can't be set to **LARGE** if the front speakers are set to **SMALL**. In this case, all bass frequencies are sent to the subwoofer.

² • If the surround speakers are set to **NO**, the surround back speaker will automatically be set to **NO**.

- If you select one surround back speaker only, make sure that speaker is hooked up to the left surround back terminal.

³ If you can't get good bass results, listen to the bass response with the subwoofer set to **PLUS** and **YES** or the front speakers set to **LARGE** and **SMALL** alternatively and let your ears judge which sounds best. If you're having problems, the easiest option is to route all the bass sounds to the subwoofer by selecting **SMALL** for the front speakers.

⁴ For more on selecting the speaker sizes, see *Speaker setting* above.

⁵ After the volume increases to the reference level, test tones will be output.

4 Adjust the level of each channel using \leftarrow/\rightarrow . If you selected **T. TONE M.**, use \uparrow/\downarrow to switch speakers.

The **T. TONE A.** setup outputs test tones in the following order (depends on speaker settings):

L → C → R → RS → SBR* → SBL* → LS → SW

**VSX-817 model only*

Adjust the level of each speaker as the test tone is emitted.¹

Speaker Distance

For good sound depth and separation from your system, you need to specify the distance of your speakers from the listening position. The receiver can then add the proper delay needed for effective surround sound.

1 Select 'SP DISTN.' from the SP SETUP menu.

2 Use \uparrow/\downarrow **to choose the speaker that you want then set the distance.**

Use \leftarrow/\rightarrow to adjust the distance of each speaker (in 0.1 meter increments).

The Input Assign menu

You only need to make settings in the Input Assign menu if you didn't hook up your digital equipment according to the default settings for the digital inputs, or if you didn't hook up your video equipment according to the default settings for the component video inputs.

1 Select 'IN ASSIG.' from the System Setup menu.

2 Use \uparrow/\downarrow **to select the setting you want to adjust then press ENTER.**

- **DIG. IN** – See *Assigning the digital inputs* below.

- **COMP. IN*** – See *Assigning the component video inputs* below.

**VSX-817 model only*

3 Press RETURN after making the adjustments necessary for each setting.

Assigning the digital inputs

- Default settings:

COAX 1 (coaxial) – DVD

COAX 2 (coaxial) – DVR

OPT 1 (optical) – CD

VSX-817 model only

OPT2 (optical) – TV

You only need to do this if you didn't connect your digital components according to the defaults above. This tells the receiver what component is connected to which terminal so it corresponds to the buttons on the remote.

1 Select DIG. IN from the IN ASSIG. menu.

2 Use \uparrow/\downarrow **to select the number of the digital input to which you've connected your digital component.**

The numbers correspond with the numbers beside the inputs on the back of the receiver.

3 Select the component that corresponds with the one you connected to that input.

- Use the \leftarrow/\rightarrow buttons and **ENTER** to select **DVD, TV, CD, CDR, DVR** or **OFF**.
- If you assign a digital input to a certain function (for example, **DVD**) then any digital inputs previously assigned to that function will automatically be switched off.

Assigning the component video inputs

- Default settings:

COMP 1 – DVD

COMP 2 – TV

COMP 3 – DVR

Note

- 1 • If you are using a Sound Pressure Level (SPL) meter, take the readings from your main listening position and adjust the level of each speaker to 75 dB SPL (C-weighting/slow reading).
 - The subwoofer test tone is output at low volumes. You may need to adjust the level after testing with an actual soundtrack.
 - You can change the channel levels at any time by using **EFFECT/CH SEL** and **+/-** on the remote control. You can set two channel levels: one for **DVD 5.1** and one for the listening modes.

If you didn't make component video connections according to the defaults above, you must assign the numbered input to the component you've connected (or else you may see the video signal of a different component). For more on this, see *Using the component video jacks* on page 16.

1 Select COMP. IN from the IN ASSIG. menu.

2 Use ↑/↓ to select the number of the component video input to which you've connected your video component.

The numbers match the numbers beside the inputs on the back of the receiver.

3 Select the component that corresponds with the one you connected to that input.

- Use the ←/→ buttons and **ENTER** to select **DVD, TV, DVR** or **OFF**.
- Make sure you have connected the audio from the component to the corresponding inputs on the rear of the receiver.
- If you connect any source component to the receiver using a component video input, you should also have your TV connected to this receiver's **COMPONENT VIDEO MONITOR OUT** jacks.

The Other setup menu

The Other menu is where you can make customized settings to reflect how you are using the receiver.

1 Select OTHER from the System Setup menu.

2 Use ↑/↓ to select the setting you want to adjust then press ENTER.

If you are doing this for the first time, you may want to adjust these settings in order:

- **DRC** – Specify the amount of dynamic range adjustment to Dolby Digital or DTS soundtracks (see *Dynamic Range Control Setup* below).

- **DUALMONO** – Isolate one channel when listening to discs with dual mono encoding (see *Dual Mono Setup* below).
- **LFE ATT** – Set the attenuator level for the LFE channel (*LFE Attenuator Setup* below).

3 Use ←/→ to make the adjustments necessary for each setting, pressing RETURN to confirm after each screen.

Dynamic Range Control Setup

- Default setting: **OFF**

Specifies the amount of dynamic range adjustment to Dolby Digital or DTS soundtracks:

- **DRC OFF** – No dynamic range adjustment (use when listening at higher volume).
- **DRC MAX** – Dynamic range is reduced (loud sounds are reduced in volume while quieter sounds are increased).
- **DRC MID** – Mid setting.

Dual Mono Setup

- Default setting: **CH1**

Specifies how dual mono encoded Dolby Digital soundtracks should be played:¹

- **CH1** – Only channel 1 is played
- **CH2** – Only channel 2 is played
- **CH1 CH2** – Both channels are played through the front speakers

LFE Attenuator Setup

- Default setting: **ATT 0 dB**

Set the LFE attenuator as necessary to prevent ultra-low bass tones (included with some Dolby Digital and DTS audio sources) from distorting the sound from the speakers:

- **LFEATT 0** – No limiting (recommended setting)
- **LFEATT 10** – 10 dB of limiting
- **LFEATT **** – No sound from LFE channel

Note

¹ This setting works only with dual mono encoded Dolby Digital and DTS soundtracks.

Chapter 7:

Using the tuner

Listening to the radio

The following steps show you how to tune in to FM and AM radio broadcasts and memorize the frequency for recall later.

1 Press AM or FM to select the tuner band.

2 Tune to a station.

There are three ways to do this:

Automatic tuning – Press and hold **TUNE +/-** (*VSX-817 model*) / **TUNING +/-** (*VSX-517 model*) for about a second. Searching automatically stops at the next station.

Manual tuning – To change the frequency one step at a time, press **TUNE +/-** (*VSX-817 model*) / **TUNING +/-** (*VSX-517 model*).

High speed tuning – Press and hold **TUNE +/-** (*VSX-817 model*) / **TUNING +/-** (*VSX-517 model*) continuously.

If the signal is weak, press the **MPX** button to switch the receiver into mono reception mode.

Tuning directly to a station

VSX-817 model only

Sometimes, you'll already know the frequency of the station you want to listen to. In this case, you can simply enter the frequency directly using the number buttons on the remote control.

1 Press FM or AM to select the band.

2 Press (SHIFT +) D.ACCESS (Direct Access).

3 Use the number buttons to enter the frequency of the radio station.

For example, to tune to **106.00** (FM), press **1, 0, 6, 0, 0**.

If you make a mistake halfway through, press **(SHIFT +) D.ACCESS** twice to cancel the frequency and start over.

Saving station presets

This receiver can memorize up to 30 stations, stored in three banks of 10 stations each.¹

1 Tune to a station you want to memorize.

2 Press T.EDIT (VSX-817 model) / (SHIFT +) TUNER EDIT (VSX-517 model).

The display shows **ST. MEMORY**, then a blinking memory class.

3 Press (SHIFT +) CLASS (VSX-817 model) / CLASS (VSX-517 model) to select one of the three classes then press ST +/- (VSX-817 model) / STATION +/- (VSX-517 model) to select the station preset you want.

Use the **MULTI JOG** dial after pressing **STATION** (front panel) to select station presets.

4 Press ENTER to store the station.

Naming station presets

You can name your presets for easy recall.

1 Choose the preset you want to name.

See *Listening to station presets* below.

2 Press T.EDIT (VSX-817 model) / (SHIFT +) TUNER EDIT (VSX-517 model).

A cursor appears at the first character position.

Note

¹ When saving an FM frequency, the **MPX** setting is also stored.

3 Input the name you want then press ENTER.

Names can be up to four characters long.

- Use the **MULTI JOG** dial (front panel) or the **ST +/-** (*VSX-817 model*) / **STATION +/-** (*VSX-517 model*) buttons (remote) to select characters, and **ENTER** to confirm. If no character is input, a space is input.



Tip

- Once you have named a station preset, you can press **(SHIFT +) TUNER DISP** (*VSX-817 model*) / **DISPLAY** (*VSX-517 model*) when listening to a station to switch the display between the name and the frequency.

Listening to station presets

You will need to have some presets stored to do this. See *Saving station presets* on page 47 if you haven't done this already.

1 Press AM or FM to select the tuner.

2 Press (SHIFT +) CLASS (VSX-817 model) / CLASS (VSX-517 model) to select the class in which the station is stored.

Press repeatedly to cycle through classes A, B and C.

3 Press ST +/- (VSX-817 model) / STATION +/- (VSX-517 model) to select the station preset you want.

Changing the frequency step

If you find that you can't tune into stations successfully, the frequency step may not be suitable for your country/region. Here's how to switch the setting:

1 Switch the receiver into standby.

2 On the front panel, press STANDBY/ON while you press and hold the TUNER EDIT button.

The channel tuning step alternates between **10K STEP** and **9K STEP** each time you do this.

Chapter 8:

Making recordings

Making an audio or a video recording

You can make an audio or a video recording from the built-in tuner, or from an audio or video source connected to the receiver (such as a CD player or TV).¹

Keep in mind you can't make a digital recording from an analog source or vice-versa, so make sure the components you are recording to/from are hooked up in the same way (see *Connecting up* on page 12 for more on connections).

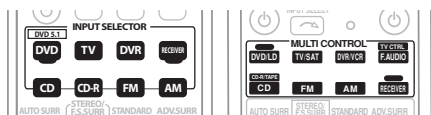

Above: VSX-517 (left) and VSX-817 (right)

1 Select the source you want to record.

Use the input select buttons (**INPUT SELECTOR**).

2 Select the input signal (if necessary).

Press **SIGNAL SELECT** (front panel) to select the input signal corresponding to the source component (see page 34 for more on this).

3 Prepare the source you want to record.

Tune to the radio station, load the CD, video, DVD etc.

4 Prepare the recorder.

Insert a blank tape, MD, video etc. into the recording device and set the recording levels.²

Refer to the instructions that came with the recorder if you are unsure how to do this. Most video recorders set the audio recording level automatically—check the component's instruction manual if you're unsure.

5 Start recording, then start playback of the source component.

Note

¹ VSX-817 model only – If you are recording a video source, you need to use the same type of connection for the source as for the recorder. For example, you can't record a component hooked up to composite video jacks with a recorder hooked up to the component video outputs (see *Connecting other video components* on page 16 for more on video connections).

² The receiver's volume, balance, tone (bass, treble, loudness), and surround effects have no effect on the recorded signal.

Chapter 9:

Controlling the rest of your system

VSX-817 model only

Setting the remote to control other components

Most components can be assigned to one of the **MULTI CONTROL** buttons using the component's manufacturer preset code stored in the remote.

However, please note that there are cases where only certain functions may be controllable after assigning the proper preset code, or the codes for the manufacturer in the remote control will not work for the model that you are using.



Note

- After one minute of inactivity, the remote automatically exits the operation.

Selecting preset codes directly

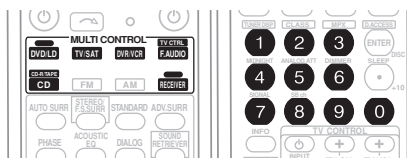

1 While pressing the RECEIVER button, press and hold the 1 button.

The LED blinks.

2 Press the MULTI CONTROL button for the component you want to control.

The LED lights on continuously.

3 Use the number buttons to enter the preset code.

You can find the preset codes on page 55.

The LED blinks again after you enter the code.

If the correct code has been input the power of the component being input will turn on or off.

The power of the component being input will only turn on or off if that component is able to be turned on directly by remote control.

- You can only input a code for the component type written on each **MULTI CONTROL** button.¹
- Even if you don't input a preset code for the TV (**TV/SAT MULTI CONTROL** button) you will be able to control your TV using the dedicated **TV CONTROL** on the remote if you have assigned it to the **TV CTRL** button.

4 Repeat steps 2 through 3 to try a different code, or to enter a code for another component you want to control.

5 When you're done, press RECEIVER.

Note

- TV codes (for example, codes for TV, CATV, Satellite TV or DTV) can only be assigned to the **TV/SAT** or **TV CTRL** button.
- You can't assign the **AM / FM** or **RECEIVER** buttons.

Direct function

- Default setting: **ON**

You can use the direct function feature to control one component using the remote control while at the same time, using your receiver to playback a different component. This could let you, for example, use the remote control to set up and listen to a CD on the receiver and then use the remote control to rewind a tape in your VCR while you continue to listen to your CD player.

When direct function is on, any component you select (using the **MULTI CONTROL** buttons) will be selected by both the receiver and the remote control. When you turn direct function off, you can operate the remote control without affecting the receiver.¹

1 While pressing the RECEIVER button, press and hold the 4 button.

The LED blinks.

2 Press the MULTI CONTROL button for the component you want to control.

The LED lights on continuously.

3 Use the number buttons to enter either 1 (direct on) or 2 (direct off).

The LED blinks again.

4 Repeat steps 2 through 3 for the other components you want to control.

5 When you're done, press RECEIVER.

Clearing all the remote control settings

You can clear all presets and restore the factory default settings.

- **While pressing the RECEIVER button, press and hold the 0 button for three seconds.**

The LED blinks three times indicating the settings have been restored to the factory presets.







Note

¹ You can't use direct function with the **AM / FM** and **TV CTRL** functions.

Controls for TVs

This remote control can control components after entering the proper codes or teaching the receiver the commands (see *Setting the remote to control other components* on page 50 for more on this). Use the **MULTI CONTROL** buttons to select the component.

- The **TV CONTROL** buttons on the remote control are dedicated to control the TV assigned to the **TV CTRL** button. If you have two TVs, assign the main TV to the **TV CTRL** button.

Button(s)	Function	Components
TV 	Switches the DTV on or off.	DTV
	Switches the TV or CATV between standby and on.	Cable TV/Satellite TV/TV
INPUT SELECT	Switches the TV input. (Not possible with all models.)	TV
TV CH +/-	Selects channels.	Cable TV/Satellite TV/TV/DTV
TV VOL +/-	Adjust the TV volume.	Cable TV/Satellite TV/TV/DTV
TOP MENU	Use as the TEXT ON/OFF button.	TV
	Select different menus from the DTV functions.	DTV
MENU	Select the menu screen.	Cable TV/Satellite TV/TV
AUDIO	Use as the AUDIO button.	Cable TV/Satellite TV/TV/DTV
GUIDE	Use as the GUIDE button for navigating.	Cable TV/Satellite TV/DTV
	Use as the TEXT OFF button.	TV
Number Buttons	Use to select a specific TV channel.	Cable TV/Satellite TV/TV/DTV
(SHIFT +) 7	Use to choose the BLUE commands on a DTV menu.	DTV
(SHIFT +) 8	Use to choose the GREEN commands on a DTV menu.	DTV
(SHIFT +) 9	Use to choose the RED commands on a DTV menu.	DTV
(SHIFT +) 0	Use to choose the YELLOW commands on a DTV menu.	DTV
	Switches DTV on or off.	DTV
	Use to choose the 'A' commands on a Satellite TV menu.	Satellite TV
	Use to choose the 'B' commands on a Satellite TV menu.	Satellite TV
	Use to choose the 'C' commands on a Satellite TV menu.	Satellite TV
	Use to choose the 'D' commands on a Satellite TV menu.	Satellite TV
	Use to choose the 'E' commands on a Satellite TV menu.	Satellite TV

Button(s)	Function	Components
+10 button	Use to add a decimal point when selecting a specific TV channel.	DTV
INFO	Press to get information on DTV programs.	DTV
ENTER/ DISC	Use to enter a channel.	Cable TV/TV/DTV
←→↓↑& ENTER	Select or adjust and navigate items on the menu screen. ENTER brings up the DTV menus.	DTV
	Press to select or adjust and navigate items on the menu screen.	Cable TV/Satellite TV/TV/DTV

Controls for other components

This remote control can control these components after entering the proper codes or teaching the receiver the commands (see *Setting the remote to control other components* on page 50 for more on this). Use the **MULTI CONTROL** buttons to select the component.

Button (s)	Function	Components
SOURCE	Press to switch the component between standby and on.	CD/MD/CD-R/VCR/DVD/LD/DVR player/Cassette deck
⏮	Press to return to the start of the current track. Repeated presses skips to the start of previous tracks.	CD/MD/CD-R/DVD/LD player
	Play the reverse side of the tape on a reversible deck.	Cassette deck
⏭	Press to advance to the start of the next track. Repeated presses skips to the start of following tracks.	CD/MD/CD-R/DVD/LD player
⏸	Pause playback or recording.	CD/MD/CD-R/VCR/DVD/LD/DVR player/Cassette deck
▶	Start playback.	CD/MD/CD-R/VCR/DVD/LD/DVR player/Cassette deck
⏩	Hold down for fast forward playback.	CD/MD/CD-R/VCR/DVD/LD/DVR player/Cassette deck
⏪	Hold down for fast reverse playback.	CD/MD/CD-R/VCR/DVD/LD/DVR player/Cassette deck
■	Stops playback (on some models, pressing this when the disc is already stopped will cause the disc tray to open).	CD/MD/CD-R/VCR/DVD/LD/DVR player/Cassette deck
● REC (SHIFT+▶)	Starts recording. To prevent accidental recording, this button must be pressed twice to take effect.	MD/CD-R/VCR/ DVR player/Cassette deck

Button (s)	Function	Components
REC STOP (SHIFT+■)	Stops recording.	DVR player
Number buttons	Directly access tracks on a program source.	CD/MD/CD-R/VCR/LD player
	Use the number buttons to navigate the on-screen display.	DVD/DVR player
+10 button	Selects tracks higher than 10. (For example, press +10 then 3 to select track 13.)	CD/MD/CD-R/VCR/LD player
ENTER/ DISC	Changes the search mode.	DVD
	Chooses the disc.	Multiple CD player
	Use as the ENTER button.	VCR
	Displays the setup screen for DVR players.	DVR player
	Changes sides of the LD.	LD player
TOP MENU	Displays the disc 'top' menu.	DVD/DVR/LD player
MENU	Displays menus concerning the current DVD or DVR you are using.	DVD/DVR player
↑	Pauses the tape.	Cassette deck
↓	Stops the tape.	Cassette deck
ENTER	Starts playback.	Cassette deck
←/→	Fast rewinds/fast forwards the tape.	Cassette deck
←→↓↑ & ENTER	Navigates DVD menu/options.	DVD/DVR player
GUIDE	Displays/changes the subtitles on multilingual DVDs.	DVR player
CH +/- (SHIFT+↓/↑)	Selects channels.	VCR/DVR player
AUDIO (SHIFT+▶▶)	Changes the audio language, channel or track.	DVD/DVR/LD/CD player
SUBTITLE (SHIFT+◀◀)	Displays/changes the subtitles on multilingual DVDs.	DVD/DVR player
HDD (SHIFT+ ◀◀)	Switches to the hard disk controls when using a DVD/HDD recorder.	DVR player
DVD (SHIFT+)	Switches to the DVD controls when using a DVD/HDD recorder.	DVR player

Preset Code List

You should have no problem controlling a component if you find the manufacturer in this list, but please note that there are cases where codes for the manufacturer in the list will not work for the model that you are using. There are also cases where only certain functions may be controllable after assigning the proper preset code.

DVD

Manufacturer Code

TOSHIBA 001
 SONY 002
 PANASONIC 003
 JVC 004
 SAMSUNG 005
 SHARP 006
 AKAI 007
 RCA 009, 011
 DENON 010
 HITACHI 012
 PHILIPS 013
 ZENITH 014
 THOMSON 015
 SONY 016 (video game)
 MICROSOFT 017
 (Videogame)
 PIONEER 000, 008, 020

LD

Manufacturer Code

SONY 101
 PANASONIC 105, 106
 PHILIPS 104
 KENWOOD 103
 RCA 107
 PIONEER 100, 111

TV TV/SAT TV/CTRL

Manufacturer Code

RCA 601, 615, 616, 617, 618
 ZENITH 603, 620
 MAGNAVOX 612, 629
 GE 611, 628
 GENERAL 666
 PHILIPS 607
 SONY 604
 PANASONIC 608, 622
 TOSHIBA 605, 626, 663
 SHARP 602, 619, 627
 HITACHI 606, 624, 625, 664
 SANYO 621, 614
 MITSUBISHI 609
 GOLDSTAR 610, 623
 JVC 613, 665
 FUNAI 658

AIWA 660

NEC 659

GRANDIENTE 630

PIONEER 600, 667

STB (SATELLITE/CATV) TV/SAT TV/CTRL

Manufacturer Code

AICHI DENSI 734
 DX ANNTENA 732, 733
 FUJITSU 722, 723, 724
 HITACHI 721
 MASPRO 729
 NEC 720
 PANASONIC 725, 726, 728
 SUMITOMO 730
 TOSHIBA 719
 JERROLD 701, 702, 703, 704,
 711, 712, 713, 714, 715, 716
 SA 705, 706, 708, 709, 731
 ZENITH 707, 717, 710
 PIONEER 700, 718

On digital STB TV/SAT TV/CTRL

Manufacturer Code

RCA 201, 203, 209
 SONY 202, 557
 ECHOSTAR 205
 PRIMESTAR 206
 BELL 208
 TOSHIBA 555
 SHARP 554
 AIWA 562, 563, 564
 HITACHI 556
 JVC 551, 552, 553
 MASPRO 559, 560, 561
 PANASONIC 558
 PIONEER 200

DTV TV/SAT TV/CTRL

Manufacturer Code

PIONEER 207, 229, 231,
 232
 PANASONIC 226, 230
 JVC 227
 TOSHIBA 228

VCR

Manufacturer Code

RCA 401, 413, 415
 ZENITH 403
 MAGNAVOX 414
 FISHER 412, 426, 427
 PANASONIC 408, 432, 433,
 462, 463, 473
 TOSHIBA 405, 464, 474
 JVC 407, 428, 429, 430, 431
 HITACHI 406, 434, 436,
 465, 472
 SONY 404, 416, 417, 457,
 458, 459, 460, 461, 475,
 476, 477, 478
 MITSUBISHI 409, 420, 421,
 422, 423, 424, 466, 467,
 470
 SANYO 410, 425, 435, 468
 SHARP 402, 418, 419, 469,
 471
 GOLDSTAR 411
 GRADIENTE 441
 PIONEER 400

DVD Recorder

Manufacturer Code

PIONEER 456, 487, 488,
 489
 TOSHIBA 485
 PANASONIC 486

TAPE

Manufacturer Code

DENON 810
 FISHER 813
 JVC 802
 PANASONIC 803
 KENWOOD 804, 807
 ONKYO 808, 809
 SONY 801, 806
 TEAC 805
 YAMAHA 811, 812
 PIONEER 800

CD

Manufacturer Code

DENON 309
 JVC 303
 PANASONIC 304, 326
 KENWOOD 310, 311,
 321
 MARANTZ 323
 ONKYO 307, 308, 320
 PHILIPS 312, 313, 322
 RCA 302, 319
 SONY 301, 316, 317,
 318
 TEAC 305, 306, 324, 325,
 327
 YAMAHA 314, 315, 328
 PIONEER 300

CD-R

Manufacturer Code

PHILIPS 346
 PIONEER 345
 YAMAHA 347

MD

Manufacturer Code

SONY 901
 KENWOOD 903
 SHARP 902
 TEAC 904
 ONKYO 905
 DENON 906
 PIONEER 900

DAT

Manufacturer Code

PIONEER 907

Chapter 10: Other connections

VSX-817 model only



Caution

- Before making or changing the connections, switch off the power and disconnect the power cord from the power outlet. Plugging in components should be the last connection you make with your system.
- Do not allow any contact between speaker wires from different terminals.
- You can use speakers with a nominal impedance between 6 Ω to 16 Ω (please see *Switching the speaker impedance* on page 60 if you plan to use speakers with an impedance of less than 8 Ω).

Second Zone speaker B setup

After selecting **SB 2ND Z** in *Surround back speaker setting* on page 39, you can use the speakers connected to the (surround back) B speaker terminals on the rear panel to listen to stereo playback in another room. See *Switching the speaker system* below for the listening options with this setup.

1 Connect a pair of speakers to the surround back speaker terminals on the rear panel.

Connect them the same way you connected your speakers in *Connecting the speakers* on page 19. Make sure to review *Hints on speaker placement* on page 20 when placing the speakers in another room.

2 Select 'SB 2ND Z' from the 'SB.SYSTEM' menu.

See *Surround back speaker setting* on page 39 to do this.

Switching the speaker system

If you selected **SB 2ND Z** in *Surround back speaker setting* on page 39, three speaker system settings are possible using the **SPEAKERS** button. If you selected **SB NORM.** or **SB BIAMP.** the speaker system is fixed as **SP▶A** or **SP▶AB** (respectively). The options below are for the **SB 2ND Z** setting only.¹

- Use the **SPEAKERS** button on the front panel to select a speaker system setting.

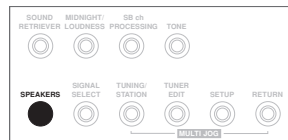

Press repeatedly to choose a speaker system option:

- **SP▶A** – Sound is output from the speakers connected to the A speaker terminals (multichannel playback is possible).
- **SP▶B** – Sound is output from the two speakers connected to speaker system B (only stereo playback is possible).
- **SP▶AB** – Sound is output from speaker system A (up to 5 channels, depending on the source), the two speakers in speaker system B, and the subwoofer. Multichannel sources (heard through speaker system A) are downmixed for stereo output from speaker system B.

Note

- 1 • The subwoofer output depends on the settings you made in *Speaker setting* on page 43. However, if **SP▶B** is selected above, no sound is heard from the subwoofer (the LFE channel is not downmixed).
 - Depending on the *Surround back speaker setting* on page 39 output from the surround back pre-out terminals may change.
 - All speaker systems (except **SB 2ND Z** connections) are switched off when headphones are connected.

Bi-amping your front speakers

Bi-amping is when you connect the high frequency driver and low frequency driver of your speakers to different amplifiers (in this case, to both front and surround back terminals) for better crossover performance. Your speakers must be bi-ampable to do this (having separate terminals for high and low) and the sound improvement will depend on the kind of speakers you're using.

1 Connect your speakers as shown below.

This illustration below shows the connections for bi-amping your front left speaker. Hook up your front right speaker in the same way.

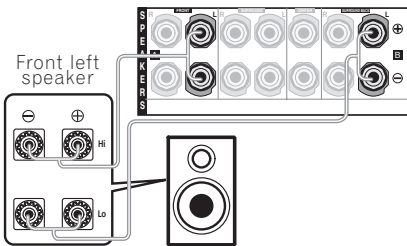

Since both front and surround back speaker terminals output the same audio, it doesn't matter which set (front or surround back) is powering which part (**Hi** or **Low**) of the speaker.

- Make sure that the + / - connections are properly inserted.

2 Select the 'SB BIAMP' setting from the 'SB.SYSTEM' menu.

See *Surround back speaker setting* on page 39 to specify how you're using the surround back speaker terminals.

Caution

- Most speakers with both **Hi** and **Low** terminals have two metal plates that connect the **Hi** to the **Low** terminals. These must be removed when you are bi-amping the speakers or you could severely damage the amplifier. See your speaker manual for more information.
- If your speakers have a removable crossover network, make sure you do not remove it for bi-amping. Doing so may damage your speakers.

Bi-wiring your speakers

The reasons for bi-wiring are basically the same as bi-amping, but additionally, interference effects within the wire could be reduced, producing better sound. Again, to do this your speakers must be bi-wireable (that is they must have separate terminals for the high and low frequencies). When bi-wiring, make sure you've selected **SB NORM.** or **SB 2ND Z** in *Surround back speaker setting* on page 39.

- **To bi-wire a speaker, connect two speaker cords to the speaker terminal on the receiver.**

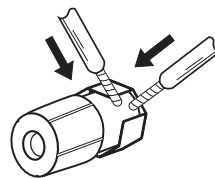

Caution

- Make sure you use a parallel (not series, which are fairly uncommon) connection when bi-wiring your speakers.
- Don't connect different speakers from the same terminal in this way.

Chapter 11: Additional information

Troubleshooting

Incorrect operations are often mistaken for trouble and malfunctions. If you think that there is something wrong with this component, check the points below. Sometimes the trouble may lie in another component. Investigate the other components and electrical appliances being used. If the trouble cannot be rectified even after exercising the checks listed below, ask your nearest Pioneer authorized service center or your dealer to carry out repair work.

- If the unit does not operate normally due to external effects such as static electricity disconnect the power plug from the outlet and insert again to return to normal operating conditions.

Problem	Remedy
The power does not turn on.	<ul style="list-style-type: none"> • Disconnect the power plug from the outlet, and insert again. • Make sure there are no loose strands of speaker wire touching the rear panel. This could cause the receiver to shut off automatically. • If the power shuts off automatically, take the unit to your nearest Pioneer authorized service center or your dealer for servicing. • The unit may have been switched on using the wrong voltage setting. Make sure you switch the VOLTAGE SELECTOR on the rear panel to the right voltage for your country or region, then reset the unit (page 60) before switching on again.
No sound is output when a function is selected.	<ul style="list-style-type: none"> • Make sure the component is connected correctly (refer to <i>Connecting up</i> on page 12). • Press MUTE on the remote control to turn muting off.
No image is output when a function is selected.	<ul style="list-style-type: none"> • Make sure the component is connected correctly (refer to <i>Connecting up</i> on page 12). • Select the correct component (use the input select buttons).
Considerable noise in radio broadcasts.	<ul style="list-style-type: none"> • Connect the antenna (page 18) and adjust the position for best reception. • Route any loose cables away from the antenna terminals and wires. • Fully extend the FM wire antenna, position for best reception, and secure to a wall (or connect an outdoor FM antenna). • Connect an additional internal or external AM antenna (page 18). • Turn off equipment causing interference or move it away from the receiver (or move antennas farther away from equipment causing noise).
Broadcast stations cannot be selected automatically.	<ul style="list-style-type: none"> • Connect an outdoor antenna (refer to page 18).

Problem	Remedy
No sound from surround or center speakers.	<ul style="list-style-type: none"> • Connect the speakers properly (refer to page 19). • Refer to <i>Speaker setting</i> on page 43 to check the speaker settings. • Refer to <i>Channel level</i> on page 44 to check the speaker levels.
<i>VSX-817 model only</i> – No sound from surround back speakers.	<ul style="list-style-type: none"> • Refer to <i>Speaker setting</i> on page 43 to check the surround back speaker settings. • Refer to <i>Channel level</i> on page 44 to check the speaker levels. • Refer to <i>Using surround back channel processing</i> on page 35 to make sure surround back processing and the sound mode are set for surround back sound.
No sound from subwoofer.	<ul style="list-style-type: none"> • Make sure the subwoofer is switched on. • If the subwoofer has a volume knob, make sure it's turned up. • The Dolby Digital or DTS source you are listening to may not have an LFE channel. • Switch the subwoofer setting in <i>Speaker setting</i> on page 43 to YES or PLUS. • Switch the <i>LFE Attenuator Setup</i> on page 46 to LFEATT 0 or LFEATT 10.
The PHASE CONTROL feature doesn't seem to have an audible effect.	<ul style="list-style-type: none"> • If applicable, check that the lowpass filter switch on your subwoofer is off, or the lowpass cutoff is set to the highest frequency setting. If there is a PHASE setting on your subwoofer, set it to 0° (or depending on the subwoofer, the setting where you think it has the best overall effect on the sound). • Make sure the speaker distance setting is correct for all speakers (see <i>Speaker Distance</i> on page 45).
Noise during playback of a cassette deck.	<ul style="list-style-type: none"> • Move the cassette deck further from your receiver, until the noise disappears.
No sound is output or a noise is output when software with DTS is played back.	<ul style="list-style-type: none"> • Set the digital volume level of the player to full, or to the neutral position.
During a playback search, noise is output from a DTS compatible CD player.	<ul style="list-style-type: none"> • This is not a malfunction, but be sure to turn the volume down to prevent the output of loud noise from your speakers.
Can't operate the remote control.	<ul style="list-style-type: none"> • Replace the batteries (refer to page 6). • Operate within 7 m, 30° of the remote sensor on the front panel (refer to page 7). • Remove the obstacle or operate from another position. • Avoid exposing the remote sensor on the front panel to direct light.
The display is dark or off.	<ul style="list-style-type: none"> • Press DIMMER on the remote repeatedly to return to the default.

Resetting the main unit

Use this procedure to reset all the receiver's settings to the factory default. Use the front panel controls to do this.

- 1 Switch the receiver into standby.**
- 2 While holding down the TONE button, press and hold the \odot STANDBY/ON button for about three seconds.**
- 3 When you see RESET? appear in the display, press the ENTER button.**
OK? shows in the display.
- 4 Press SETUP to confirm.**
OK appears in the display to indicate that the receiver has been reset to the factory default settings.

Switching the speaker impedance

We recommend using speakers of 8 Ω with this system, but it is possible to switch the impedance setting if you plan to use speakers with a 6 Ω impedance rating.

- **With the receiver in standby, press \odot STANDBY/ON while holding down the QUICK SETUP (VSX-517) / SPEAKERS (VSX-817) button.**

Each time you do this, you switch between the impedance settings:

- **SP 6 OHM** – Use this setting if your speakers are rated at 6 Ω .
- **SP 8 OHM** – Use this setting if your speakers are rated at 8 Ω or more.

Power cord caution

Handle the power cord by the plug. Do not pull out the plug by tugging the cord and never touch the power cord when your hands are wet as this could cause a short circuit or an electric shock. Do not place the unit, a piece of

furniture, etc., on the power cord, or pinch the cord. Never make a knot in the cord or tie it with other cords. The power cords should be routed such that they are not likely to be stepped on. A damaged power cord can cause a fire or give you an electrical shock. Check the power cord once in a while. When you find it damaged, ask your nearest Pioneer authorized service center or your dealer for a replacement.

Specifications

Amplifier section

- **Maximum power output (surround / 1 kHz, THD 10 %, 8 Ω)**
 Front 130 W per channel
 Center 130 W
 Surround 130 W per channel
 Surround Back (*VSX-817 model only*) 130 W per channel
- **Continuous power output (stereo)**
 Front 100 W + 100 W
 (DIN 1 kHz, THD 1.0 %, 8 Ω)
- **Rated power output (surround / 20 Hz to 20 kHz, THD 0.08 %, 8 Ω)**
 Front 90 W per channel
 Center 90 W
 Surround 90 W per channel
 Surround Back (*VSX-817 model only*) 90 W per channel

Audio section

- **Input (Sensitivity/Impedance)**
 CD, DVR/VCR, CD-R/TAPE/MD,
 DVD/LD, TV/SAT 200 mV/47 kΩ
- **Frequency response**
 CD, DVR/VCR, CD-R/TAPE/MD, DVD/LD,
 TV/SAT 5 Hz to 100 000 Hz ± 3 dB
- **Output (Level/Impedance)**
 DVR/VCR REC, CD-R/TAPE/
 MD REC 200 mV/2.2 kΩ
- **Tone control**
 Bass ± 6 dB (100 Hz)
 Treble ± 6 dB (10 kHz)
 Loudness +10 dB/+5 dB (100 Hz/10 kHz)
 (at volume level -50 dB)
- **Signal-to-Noise Ratio DIN (Continuous rated power output/ 50 mW)**
 CD, DVR/VCR, CD-R/TAPE/MD,
 DVD/LD, TV/SAT 88 dB/64 dB

- **Signal-to-Noise Ratio (IHF, short circuited, A network)**
 CD, DVR/VCR, CD-R/TAPE/MD,
 DVD/LD, TV/SAT 96 dB

- **Signal-to-Noise Ratio [EIA, at 1 W (1 kHz)]**
 CD, DVR/VCR, CD-R/TAPE/MD,
 DVD/LD, TV/SAT 79 dB

Video Section

- **Input (Sensitivity/Impedance)**
 DVR/VCR, DVD/LD, TV/SAT 1 V_{p-p}/75 Ω
- **Output (Level/Impedance)**
 DVR/VCR, MONITOR OUT 1 V_{p-p}/75 Ω
- **Frequency response**
 DVR/VCR, DVD/LD,
 TV/SAT \Leftrightarrow MONITOR 5 Hz to 7 MHz ± 0 dB
 Signal-to-Noise Ratio 55 dB
 Crosstalk 50 dB

Component video section

- **Input (Sensitivity/Impedance)**
 DVD/LD, TV/SAT 1 V_{p-p}/75 Ω
- **Output (Level/Impedance)**
 MONITOR OUT 1 V_{p-p}/75 Ω
- **Frequency response**
 DVD/LD,
 TV/SAT \Leftrightarrow MONITOR 5 Hz to 40 MHz ± 3 dB
 Signal-to-Noise Ratio 60 dB

FM Tuner Section

- Frequency Range 87.5 MHz to 108 MHz
- Usable Sensitivity Mono: 13.2 dBf, IHF
 (1.3 μV/ 75 Ω)
 50 dB Quieting Sensitivity Mono: 20.2 dB
 Stereo: 38.6 dBf
- Signal-to-Noise Ratio ... Mono: 73 dB (at 85 dBf)
 Stereo: 70 dB (at 85 dBf)
- Distortion Stereo: 0.5 % (1 kHz)
- Alternate Channel Selectivity ... 60 dB (400 kHz)
- Stereo Separation 40 dB (1 kHz)
- Frequency Response 30 Hz to 15 kHz
 (± 1 dB)
- Antenna Input (DIN) 75 Ω unbalanced

AM Tuner Section

Frequency Range

9 kHz step 531 kHz to 1602 kHz

10 kHz step 530 kHz to 1700 kHz

Sensitivity (IHF, Loop antenna) 350 μ V/m

Signal-to-Noise Ratio 50 dB

Antenna Loop antenna

Miscellaneous

Power requirements

Black model AC 110 V/AC 120 V to 127 V/
AC 220 V/AC 230 V to 240 V, 50 Hz/60 Hz

Silver model

Australia model AC 230 V to 240 V, 50 Hz

All other models. . . AC 110 V/AC 120 V to 127 V/
AC 220 V/AC 230 to 240 V, 50 Hz/60 Hz

Power consumption

VSX-517 280 W

VSX-817 360 W

In standby 0.5 W (AC 220 V/50 Hz)

Dimensions

VSX-517

. 420 (W) mm x 158 (H) mm x 348 (D) mm

VSX-817

. 420 (W) mm x 158 (H) mm x 352.5 (D) mm

Weight (without package)

VSX-517 8.5 kg

VSX-817 8.6 kg

Furnished Parts

AM loop antenna 1

FM wire antenna 1

Dry cell batteries (AA size IEC R6) 2

Remote control 1

Setup microphone (VSX-817 model only) 1

Power cords:

VSX-517/817-K (black models) 2

(Round 2-pin type and Australian type)

VSX-517/817-S

(silver models – Except Australian model) . . . 3

(Round 2-pin type, flat blade 2-pin type,

UK 3-pin type)

Power plug adaptor (VSX-517/817-K only) 1

J-shaped plug 1

These operating instructions



Note

- Specifications and the design are subject to possible modifications without notice, due to improvements.

Cleaning the unit

- Use a polishing cloth or dry cloth to wipe off dust and dirt.
- When the surface is dirty, wipe with a soft cloth dipped in some neutral cleanser diluted five or six times with water, and wrung out well, and then wipe again with a dry cloth. Do not use furniture wax or cleansers.
- Never use thinners, benzene, insecticide sprays or other chemicals on or near this unit, since these will corrode the surface.

VSX-517 model

Manufactured under license from Dolby Laboratories. "Dolby", "Pro Logic" and the double-D symbol are trademarks of Dolby Laboratories.

"DTS" is a registered trademark of DTS, Inc. and "DTS 96/24" is a trademark of DTS, Inc.

VSX-817 model

Manufactured under license from Dolby Laboratories. "Dolby", "Pro Logic", "Surround EX", and the double-D symbol are trademarks of Dolby Laboratories.

"DTS" and "DTS-ES | Neo:6" are registered trademarks of DTS, Inc. "96/24" is a trademark of DTS, Inc.

Published by Pioneer Corporation.
Copyright © 2007 Pioneer Corporation.
All rights reserved.

PIONEER CORPORATION

4-1, Meguro 1-Chome, Meguro-ku, Tokyo 153-8654, Japan

PIONEER ELECTRONICS (USA) INC.

P.O. BOX 1540, Long Beach, California 90801-1540, U.S.A. TEL: (800) 421-1404

PIONEER ELECTRONICS OF CANADA, INC.

300 Allstate Parkway, Markham, Ontario L3R 0P2, Canada TEL: 1-877-283-5901, 905-479-4411

PIONEER EUROPE NV

Haven 1087, Keetberglaan 1, B-9120 Melsele, Belgium TEL: 03/570.05.11

PIONEER ELECTRONICS ASIACENTRE PTE. LTD.

253 Alexandra Road, #04-01, Singapore 159936 TEL: 65-6472-7555

PIONEER ELECTRONICS AUSTRALIA PTY. LTD.

178-184 Boundary Road, Braeside, Victoria 3195, Australia, TEL: (03) 9586-6300

PIONEER ELECTRONICS DE MEXICO S.A. DE C.V.

Bldv.Manuel Avila Camacho 138 10 piso Col.Lomas de Chapultepec, Mexico,D.F. 11000 TEL: 55-9178-4270

K002_B_En

Free Manuals Download Website

<http://myh66.com>

<http://usermanuals.us>

<http://www.somanuals.com>

<http://www.4manuals.cc>

<http://www.manual-lib.com>

<http://www.404manual.com>

<http://www.luxmanual.com>

<http://aubethermostatmanual.com>

Golf course search by state

<http://golfingnear.com>

Email search by domain

<http://emailbydomain.com>

Auto manuals search

<http://auto.somanuals.com>

TV manuals search

<http://tv.somanuals.com>