

Pioneer

**AUDIO/VIDEO MULTI-CHANNEL
RECEIVER**

**VSX-1019AH-K
VSX-919AH-K**

Register your product at

<http://www.pioneerelectronics.com> (US)

<http://www.pioneerelectronics.ca> (Canada)

• **Protect your new investment**

The details of your purchase will be on file for reference in the event of an insurance claim such as loss or theft.

• **Receive free tips, updates and service bulletins on your new product**

• **Improve product development**

Your input helps us continue to design products that meet your needs.

• **Receive a free Pioneer newsletter**

Registered customers can opt in to receive a monthly newsletter.

Operating Instructions

WARNING

This equipment is not waterproof. To prevent a fire or shock hazard, do not place any container filled with liquid near this equipment (such as a vase or flower pot) or expose it to dripping, splashing, rain or moisture.

D3-4-2-1-3_B_En

WARNING

Before plugging in for the first time, read the following section carefully.

The voltage of the available power supply differs according to country or region. Be sure that the power supply voltage of the area where this unit will be used meets the required voltage (e.g., 230 V or 120 V) written on the rear panel.

D3-4-2-1-4_A_En

This product contains mercury. Disposal of this material may be regulated due to environmental considerations. For disposal or recycling information, please contact your local authorities or the Electronics Industries Alliance : www.eiae.org.

K057_En

If the AC plug of this unit does not match the AC outlet you want to use, the plug must be removed and appropriate one fitted. Replacement and mounting of an AC plug on the power supply cord of this unit should be performed only by qualified service personnel. If connected to an AC outlet, the cut-off plug can cause severe electrical shock. Make sure it is properly disposed of after removal. The equipment should be disconnected by removing the mains plug from the wall socket when left unused for a long period of time (for example, when on vacation).

D3-4-2-2-1a_A_En

WARNING: Handling the cord on this product or cords associated with accessories sold with the product will expose you to chemicals listed on proposition 65 known to the State of California and other governmental entities to cause cancer and birth defect or other reproductive harm.

Wash hands after handling

D36-P4_A_En

IMPORTANT NOTICE – THE SERIAL NUMBER FOR THIS EQUIPMENT IS LOCATED IN THE REAR. PLEASE WRITE THIS SERIAL NUMBER ON YOUR ENCLOSED WARRANTY CARD AND KEEP IN A SECURE AREA. THIS IS FOR YOUR SECURITY.

D1-4-2-6-1_En

NOTE: This equipment has been tested and found to comply with the limits for a Class B digital device, pursuant to Part 15 of the FCC Rules. These limits are designed to provide reasonable protection against harmful interference in a residential installation. This equipment generates, uses, and can radiate radio frequency energy and, if not installed and used in accordance with the instructions, may cause harmful interference to radio communications. However, there is no guarantee that interference will not occur in a particular installation. If this equipment does cause harmful interference to radio or television reception, which can be determined by turning the equipment off and on, the user is encouraged to try to correct the interference by one or more of the following measures:

- Reorient or relocate the receiving antenna.
- Increase the separation between the equipment and receiver.
- Connect the equipment into an outlet on a circuit different from that to which the receiver is connected.
- Consult the dealer or an experienced radio/TV technician for help.

D8-10-1-2_En

This Class B digital apparatus complies with Canadian ICES-003.

Cet appareil numérique de la Classe B est conforme à la norme NMB-003 du Canada.

D8-10-1-3_EF

Information to User

Alteration or modifications carried out without appropriate authorization may invalidate the user's right to operate the equipment.

D8-10-2_En

CAUTION: This product satisfies FCC regulations when shielded cables and connectors are used to connect the unit to other equipment. To prevent electromagnetic interference with electric appliances such as radios and televisions, use shielded cables and connectors for connections.

D8-10-3a_En

FEDERAL COMMUNICATIONS COMMISSION DECLARATION OF CONFORMITY

This device complies with part 15 of the FCC Rules. Operation is subject to the following two conditions: (1) This device may not cause harmful interference, and (2) this device must accept any interference received, including interference that may cause undesired operation.

Product Name: AUDIO/VIDEO MULTI-CHANNEL RECEIVER
Model Number: VSX-1019AH-K, VSX-919AH-K
Responsible Party Name: PIONEER ELECTRONICS SERVICE INC.
Address: 1925 E. DOMINGUEZ ST. LONG BEACH, CA 90801-1760, USA
Phone: 1-800-421-1404

IMPORTANT



The lightning flash with arrowhead symbol, within an equilateral triangle, is intended to alert the user to the presence of uninsulated "dangerous voltage" within the product's enclosure that may be of sufficient magnitude to constitute a risk of electric shock to persons.

CAUTION

RISK OF ELECTRIC SHOCK
DO NOT OPEN

CAUTION:

TO PREVENT THE RISK OF ELECTRIC SHOCK, DO NOT REMOVE COVER (OR BACK). NO USER-SERVICEABLE PARTS INSIDE. REFER SERVICING TO QUALIFIED SERVICE PERSONNEL.



The exclamation point within an equilateral triangle is intended to alert the user to the presence of important operating and maintenance (servicing) instructions in the literature accompanying the appliance.

D3-4-2-1-1_En-A

IMPORTANT SAFETY INSTRUCTIONS

- 1) Read these instructions.
- 2) Keep these instructions.
- 3) Heed all warnings.
- 4) Follow all instructions.
- 5) Do not use this apparatus near water.
- 6) Clean only with dry cloth.
- 7) Do not block any ventilation openings. Install in accordance with the manufacturer's instructions.
- 8) Do not install near any heat sources such as radiators, heat registers, stoves, or other apparatus (including amplifiers) that produce heat.
- 9) Do not defeat the safety purpose of the polarized or grounding-type plug. A polarized plug has two blades with one wider than the other. A grounding type plug has two blades and a third grounding prong. The wide blade or the third prong are provided for your safety. If the provided plug does not fit into your outlet, consult an electrician for replacement of the obsolete outlet.
- 10) Protect the power cord from being walked on or pinched particularly at plugs, convenience receptacles, and the point where they exit from the apparatus.
- 11) Only use attachments/accessories specified by the manufacturer.
- 12) Use only with the cart, stand, tripod, bracket, or table specified by the manufacturer, or sold with the apparatus. When a cart is used, use caution when moving the cart/apparatus combination to avoid injury from tip-over.
- 13) Unplug this apparatus during lightning storms or when unused for long periods of time.
- 14) Refer all servicing to qualified service personnel. Servicing is required when the apparatus has been damaged in any way, such as power-supply cord or plug is damaged, liquid has been spilled or objects have fallen into the apparatus, the apparatus has been exposed to rain or moisture, does not operate normally, or has been dropped.



P1-4-2-2_En

VENTILATION CAUTION

When installing this unit, make sure to leave space around the unit for ventilation to improve heat radiation (at least 60 cm at top, 10 cm at rear, and 30 cm at each side).

WARNING

Slots and openings in the cabinet are provided for ventilation to ensure reliable operation of the product, and to protect it from overheating. To prevent fire hazard, the openings should never be blocked or covered with items (such as newspapers, table-cloths, curtains) or by operating the equipment on thick carpet or a bed.

D3-4-2-1-7b_A_En

Operating Environment

Operating environment temperature and humidity: +5 °C to +35 °C (+41 °F to +95 °F); less than 85 %RH (cooling vents not blocked)

Do not install this unit in a poorly ventilated area, or in locations exposed to high humidity or direct sunlight (or strong artificial light)

D3-4-2-1-7c_A_En

This product is for general household purposes. Any failure due to use for other than household purposes (such as long-term use for business purposes in a restaurant or use in a car or ship) and which requires repair will be charged for even during the warranty period.

K041_En

WARNING

To prevent a fire hazard, do not place any naked flame sources (such as a lighted candle) on the equipment.

D3-4-2-1-7a_A_En

CAUTION

The STANDBY/ON switch on this unit will not completely shut off all power from the AC outlet. Since the power cord serves as the main disconnect device for the unit, you will need to unplug it from the AC outlet to shut down all power. Therefore, make sure the unit has been installed so that the power cord can be easily unplugged from the AC outlet in case of an accident. To avoid fire hazard, the power cord should also be unplugged from the AC outlet when left unused for a long period of time (for example, when on vacation).

D3-4-2-2-2a_A_En

CAUTION

To prevent fire hazard, the Class 2 Wiring Cable should be used for connection with speaker, and should be routed away from hazards to avoid damage to the insulation of the cable.

For U.S. and Australia Model



Thank you for buying this Pioneer product. Please read through these operating instructions so you will know how to operate your model properly. After you have finished reading the instructions, put them away in a safe place for future reference.

Contents

01 Before you start

Checking what's in the box	7
Installing the receiver	7
Loading the batteries	7

02 Controls and displays

Front panel	8
Display	9
Remote control	11
Operating range of remote control unit	13

03 Connecting your equipment

Rear panel	14
Determining the speakers' application	15
Other speaker connection	16
Placing the speakers	17
Some tips for improving sound quality	17
Connecting the speakers	18
Installing your speaker system	19
Standard 5.1/6.1/7.1-channel surround connections	19
Bi-amping your speakers	20
Bi-wiring your speakers	20
Selecting the Surr Back system	21
Zone 2 setup	21
Speaker B setup	21
Bi-Amping setup	21
About the audio connection	22
About the video converter	22
Connecting your TV and playback components	23
Connecting using HDMI	23
Connecting your DVD player with no HDMI output	25
Connecting your TV with no HDMI input	26
Connecting a satellite/cable receiver or other set-top box	27
Connecting a HDD/DVD recorder, VCR and other video sources	28
Connecting the multichannel analog inputs	28
Connecting other audio components	29
About the WMA9 Pro decoder	29
Connecting AM/FM antennas	30
Connecting external antennas	30
MULTI-ZONE setup	31
Making MULTI-ZONE connections	31
Connecting an IR receiver	32
Operating other Pioneer components with this unit's sensor	32
Connecting your SiriusConnect™ Tuner	33

Connecting a component to the front panel inputs	34
Connecting an iPod	34
Connecting a USB device	35
Plugging in the receiver	35

04 Basic Setup

Switching the speaker impedance	36
Changing the OSD display language (OSD Language)	36
Automatically setting up for surround sound (Auto MCACC)	37
Problems when using the Auto MCACC Setup	39
The Input Setup menu	39
Input function default and possible settings	40

05 Basic playback

Playing a source	41
Playing a source with HDMI connection	42
Selecting the multichannel analog inputs	42
Playing an iPod	43
Playing back audio files stored on an iPod	43
Playing a USB device	45
Playing back audio files stored on a USB memory device	45
Playing back photo files stored on a USB memory device	47
About playable file formats	48
Using SIRIUS Radio	49
Listening to SIRIUS Radio	49
Saving channel presets	50
Using the SIRIUS Menu	51
Listening to the radio	51
Improving FM sound	51
Using Neural THX	51
Tuning directly to a station	51
Saving station presets	52
Naming station presets	52
Listening to station presets	52

06 Listening to your system

Auto playback	53
Listening in surround sound	53
Standard surround sound	53
Using the Advanced surround effects	54
Listening in stereo	55
Using Front Stage Surround Advance	55
Using Stream Direct	56
Using surround back channel processing	56
Using the Virtual Surround Back mode	57
Setting the Up Mix function	57
Selecting MCACC presets	58
Choosing the input signal	58
Better sound using Phase Control	59

07 KURO LINK

Making the KURO LINK connections	60
Cautions on the KURO LINK function	61
About connections with a product of a different brand that supports the KURO LINK function	61
KURO LINK Setup	62
Setting the PQLS function	62
Before using synchronization	63
Synchronized amp mode	63
Synchronized amp mode operations	63
Canceling synchronized amp mode	63

08 Using other functions

Setting the Audio options	64
Setting the Video options	67
Switching the speaker system	69
Using the MULTI-ZONE controls	69
Making an audio or a video recording	70
Reducing the level of an analog signal	71
Using the sleep timer	71
Dimming the display	71
Checking your system settings	71
Resetting the system	72
Default system settings	72

09 Controlling the rest of your system

Operating multiple receivers	73
Setting the remote to control other components	73
Selecting preset codes directly	73
Resetting the remote control presets	74
Default preset codes	74
Controls the components	74

10 The Advanced MCACC menu

Making receiver settings from the Advanced MCACC menu	77
Automatic MCACC (Expert)	78
Manual MCACC setup	82
Fine Channel Level	83
Fine Speaker Distance	83
Standing Wave	85
Acoustic Calibration EQ Adjust	85
Acoustic Calibration EQ Professional	86
Checking MCACC Data	89
Speaker Setting	89
Channel Level	89
Speaker Distance	90
Standing Wave	90
Acoustic Cal EQ	90
Data Management	91
Renaming MCACC presets	91
Copying MCACC preset data	92
Clearing MCACC presets	92

11 The system and the other setup

Making receiver settings from the System Setup menu	93
Manual speaker setup	94
Surround back speaker setting	94
Speaker Setting	95
Channel Level	96
Speaker Distance	97
X-Curve	98
The Other Setup menu	98
Multi Channel Input Setup	99
ZONE Audio Setup	99
Power ON Level Setup	100
Volume Limit Setup	100
Remote Control Mode Setup	101
Flicker Reduction Setup	101

12 Additional information

Troubleshooting	102
Power	102
No sound	103
Other audio problems	105
Video	106
Settings	106
Professional Calibration EQ graphical output	107
Display	108
Remote control	109
HDMI	109
Important information regarding the HDMI connection	110
USB interface	111
SIRIUS radio messages	112
Surround sound formats	113
Dolby	113
DTS	113
Windows Media Audio 9 Professional	113
About iPod	113
About SIRIUS	114
About Neural – THX Surround	114
Auto Surround, ALC and Stream Direct with different input signal formats	115
Preset code list	116
Specifications	125
Cleaning the unit	126
Warranty	127

Flow of settings on the receiver

The unit is a full-fledged AV receiver equipped with an abundance of functions and terminals. It can be used easily after following the procedure below to make the connections and settings.

The colors of the steps indicate the following:

Required setting item

Setting to be made as necessary

1 Before you start

- Checking what's in the box (page 7)
- Loading the batteries (page 7)



2 Determining the speakers' application (page 15)

- 7.1ch surround connection
- 5.1ch surround & Front Bi-amping connection
- 5.1ch surround & Zone 2 connection
- 5.1ch surround & Speaker B connection



3 Connecting the speakers

- Placing the speakers (page 17)
- Connecting the speakers (page 18)
- Standard 5.1/6.1/7.1-channel surround connections (page 19)
- Bi-amping your speakers (page 20)



4 Connecting the components

- About the audio connection (page 22)
- About the video converter (page 22)
- Connecting your TV and playback components (page 23)
- Connecting AM/FM antennas (page 30)
- Plugging in the receiver (page 35)



5 Switching the speaker impedance (page 36)

(Only if the impedance of the connected speakers is 6 Ω to 8 Ω)



6 Power On



7 Changing the OSD display language (OSD Language) (page 36)



8 Surround back speaker setting (page 94)



9 MCACC speaker settings

- Automatically setting up for surround sound (Auto MCACC) (page 37)



10 The Input Setup menu (page 39)

(When using connections other than the recommended connections)



11 Basic playback (page 41)



12 Adjusting the sound and picture quality as desired

- Using the various listening modes
- Using surround back channel processing (page 56)
- Better sound using Phase Control (page 59)
- Switches on/off the Acoustic Calibration EQ, Sound retriever or Dialog Enhancement (page 64)
- Change the channel level while listening (*Tip* on page 97)
- Measure the all EQ type (SYMMETRY/ALL CH ADJ/FRONT ALIGN) (page 78)
- Setting the PQLS function (page 62)
- Setting the Audio options (Tone, Loudness or Sound delay, etc.) (page 64)
- Setting the Video options (page 67)



13 Other optional adjustments and settings

- KURO LINK Setup (page 62)
- The Advanced MCACC menu (page 77)
- The system and the other setup (page 93)



14 Making maximum use of the remote control

- Operating multiple receivers (page 73)
- Setting the remote to control other components (page 73)

Chapter 1: Before you start

Checking what's in the box

Please check that you've received the following supplied accessories:

- Setup microphone (cable: 5 m (16.4 ft.))
- Remote control unit
- AA size IEC R6 dry cell batteries (to confirm system operation) x2
- AM loop antenna
- FM wire antenna
- iPod cable
- These operating instructions

Installing the receiver

- When installing this unit, make sure to put it on a level and stable surface.

Don't install it on the following places:

- on a color TV (the screen may distort)
- near a cassette deck (or close to a device that gives off a magnetic field). This may interfere with the sound.
- in direct sunlight
- in damp or wet areas
- in extremely hot or cold areas
- in places where there is vibration or other movement
- in places that are very dusty
- in places that have hot fumes or oils (such as a kitchen)
- Do not touch this receiver's bottom panel while the power is turned on. The bottom panel gets hot when the power is on, and touching it could cause burns.

Loading the batteries

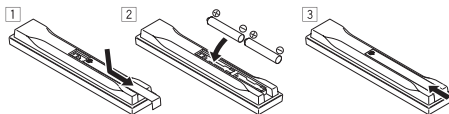

CAUTION

Incorrect use of batteries may result in such hazards as leakage and bursting. Observe the following precautions:

- Never use new and old batteries together.
- Insert the plus and minus sides of the batteries properly according to the marks in the battery case.
- Batteries with the same shape may have different voltages. Do not use different batteries together.
- When disposing of used batteries, please comply with governmental regulations or environmental public instruction's rules that apply in your country or area.
- **WARNING**
Do not use or store batteries in direct sunlight or other excessively hot place, such as inside a car or near a heater. This can cause batteries to leak, overheat, explode or catch fire. It can also reduce the life or performance of batteries.

(Symbol examples for batteries)

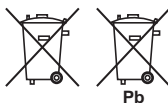

These symbols are only valid in the European Union.

K058c_A1_En

Chapter 2:

Controls and displays

Front panel

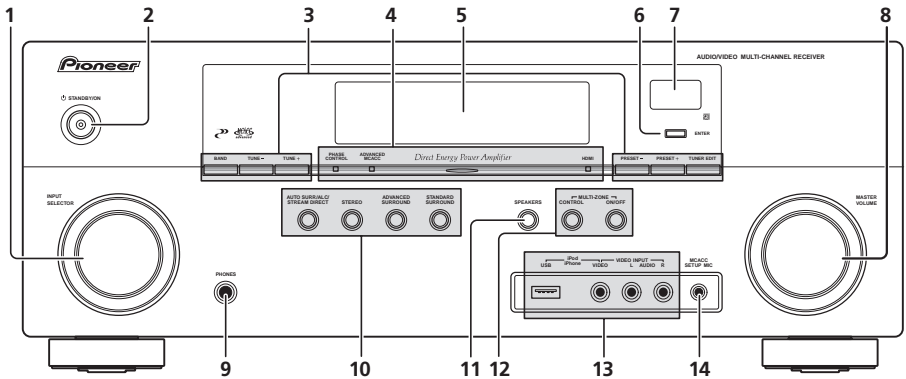
**1 INPUT SELECTOR dial**

Use to select an input function.

2  STANDBY/ON

Switches the receiver between on and standby. Power indicator lights when the receiver is on.

When the **KURO LINK** function is set to **ON**, the power indicator lights dimly when the power is in standby.

3 Tuner controls

BAND – Switches between AM and FM radio bands (page 51).

TUNE +/- – Use to find radio frequencies (page 51).

PRESET +/- – Use to find preset stations (page 52).

TUNER EDIT – Use with **TUNE +/-**, **PRESET +/-** and **ENTER** to memorize and name stations for recall (page 52).

4 PHASE CONTROL indicator – Lights to indicate Phase Control is selected (page 59).

ADVANCED MCACC indicator – Lights when **EQ** is set to **ON** in the **AUDIO PARAMETER** menu.

HDMI indicator – Blinks when connecting an HDMI-equipped component; lights when the component is connected (page 23).

5 Character display

See *Display* on page 9.

6 ENTER**7 Remote sensor**

Receives the signals from the remote control (see *Operating range of remote control unit* on page 13).

8 MASTER VOLUME dial

9 PHONES jack

Use to connect headphones. When the headphones are connected, there is no sound output from the speakers.

10 Listening mode buttons

AUTO SURR/ALC/STREAM DIRECT – Switches between Auto Surround (page 53), Auto level control mode and Stream Direct mode (page 56).

STEREO – Switches between stereo playback, and Front Stage Surround Advance modes (page 55).

ADVANCED SURROUND – Use to switch between the various surround modes (page 54).

STANDARD SURROUND – Press for Standard decoding and to switch between the various Pro Logic IIx and Neo:6 options (page 53).

11 SPEAKERS

Use to change the speaker system (page 69).

12 MULTI-ZONE controls

If you've made MULTI-ZONE connections (see *MULTI-ZONE setup* on page 31) use these controls to control the sub zone from the main zone (see *Using the MULTI-ZONE controls* on page 69).

13 iPod/iPhone/USB, VIDEO INPUT terminals

Use to connect your Apple iPod as an audio and video source, or connect a USB device for audio and photo playback (page 34, 35).

See *Connecting a component to the front panel inputs* on page 34.

14 MCACC SETUP MIC jack

Use to connect the supplied microphone (page 37).

Display

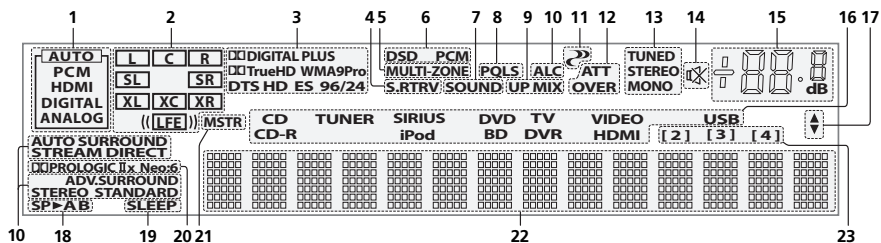

1 SIGNAL indicators

Light to indicate the currently selected input signal. **AUTO** lights when the receiver is set to select the input signal automatically (page 58).

2 Program format indicators

Light to indicate the channels being input when PCM signals are being input. They do not indicate the audio signals being output from the receiver.

L/R – Left front/Right front channel

C – Center channel

SL/SR – Left surround/Right surround channel

LFE – Low frequency effects channel (the) indicators light when an LFE signal is being input)

XL/XR – Two channels other than the ones above

XC – Either one channel other than the ones above, the mono surround channel or matrix encode flag

3 Digital format indicators

Light when a signal encoded in the corresponding format is detected.

4 S.RTRV

Lights when the Sound Retriever function is active (page 65).

5 MULTI-ZONE

Lights when the MULTI-ZONE feature is active (page 69).

6 DSD PCM – Light during DSD (Direct Stream Digital) to PCM conversion with SACDs.

PCM – Lights during playback of PCM signals.

7 SOUND

Lights when any of the Midnight, Loudness or tone controls feature is selected (page 64).

Lights when Dialog Enhancement is switched on.

8 PQLS

Lights when the PQLS feature is active (page 62).

9 UP MIX

Lights when the UP Mix is switched on (page 57).

10 Listening mode indicators

AUTO SURROUND – Lights when the Auto Surround feature is switched on (page 53).

ALC – Lights when the ALC (Auto level control) mode is selected (page 56).

STREAM DIRECT – Lights when Direct/ Pure Direct is selected (page 56).

ADV.SURROUND – Lights when one of the Advanced Surround modes has been selected (page 54).

STEREO – Lights when stereo listening is switched on (page 55).

STANDARD – Lights when one of the Standard Surround modes is switched on (page 53).

11  (PHASE CONTROL)

Lights when the Phase Control is switched on (page 59).

12 Analog signal indicators

Light to indicate reducing the level of an analog signal (page 71).

13 Tuner indicators

TUNED – Lights when a broadcast is being received.

STEREO – Lights when a stereo FM broadcast is being received in auto stereo mode.

MONO – Lights when the mono mode is set using **MPX**.

14 

Lights when the sound is muted (page 13).

15 Master volume level

Shows the overall volume level.

"---" indicates the minimum level, and "+12dB" indicates the maximum level.



16 Input function indicators

Light to indicate the input function you have selected.

17 Scroll indicators

Light when there are more selectable items when making the various settings.

18 Matrix decoding format indicators

 **PRO LOGIC IIx** – This lights to indicate  Pro Logic II /  Pro Logic IIx decoding (page 53).

Neo:6 – When one of the Neo:6 modes of the receiver is on, this lights to indicate Neo:6 processing (page 53).

19 Speaker indicators

Lights to indicate the current speaker system, **A** and/or **B** (page 69).

20 SLEEP

Lights when the receiver is in sleep mode (page 71).

21 MSTR

Lights during playback of DTS-HD Master Audio signal.

22 Character display

Displays various system information.

23 Remote control mode indicator

Lights to indicate the receiver's remote control mode setting. (Not displayed when set to **1.**) (page 73)

Remote control

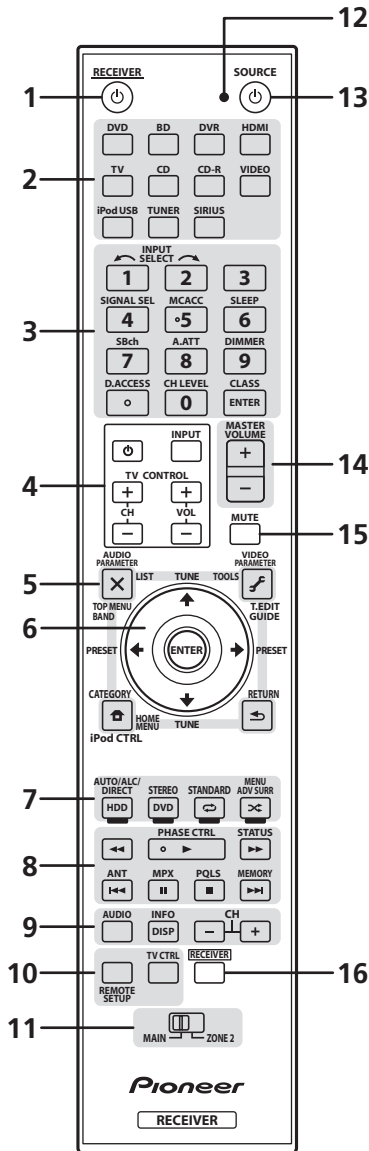

The remote has been conveniently color-coded according to component control using the following system:

- **White** – Receiver control, TV Control
- **Blue** – Other controls

1 RECEIVER

This switches between standby and on for this receiver.

2 Input function buttons

Press to select control of other components (see *Controlling the rest of your system* on page 73).

3 Number buttons and other receiver/ component controls

Use the number buttons to directly select a radio frequency (page 51) or the tracks on a CD, DVD, etc.

ENTER can be used to enter commands for TV or DTV.

Press **RECEIVER** first to access:

INPUT SELECT – Use to select the input function (page 41).

SIGNAL SEL – Use to select an input signal (page 58).

MCACC – Press to switch between MCACC presets (page 58).

SLEEP – Use to put the receiver in sleep mode and select the amount of time before sleep (page 71).

SBch – Use to select the surround back/virtual surround back channel mode (page 56).

A.ATT – Attenuates (lowers) the level of an analog input signal to prevent distortion (page 71).

DIMMER – Dims or brightens the display (page 71).

CH LEVEL – Press repeatedly to select a channel, then use **◀/▶** to adjust the level (page 97).

Press **TUNER** first to access:

D.ACCESS – After pressing, you can access a radio station directly using the number buttons (page 51).

CLASS – Switches between the seven banks (classes) of radio station presets (page 52).

4 TV CONTROL buttons

These buttons are dedicated to control the TV assigned to **TV** operation selector switch. Thus if you only have one TV to hook up to this system assign it to the **TV** operation selector switch (see page 75 for more on this).

⏻ – Use to turn on/off the power of the TV.

INPUT – Use to select the TV input signal.

CH +/- – Use to select channels.

VOL +/- – Use to adjust the volume on your TV.

5 Tuner/component control buttons/HOME MENU

These button controls can be accessed after you have selected the corresponding input function button (**DVD**, **DVR**, **TV**, etc.). The **BAND** and **T.EDIT** tuner controls are explained on page 51 and page 52.

Press **RECEIVER** first to access:

AUDIO PARAMETER – Use to access the Audio options (page 64).

VIDEO PARAMETER – Use to access the Video options (page 67).

HOME MENU – Use to access the Home Menu (pages 36, 39, 62, 77, 93 and 98).

RETURN – Press to confirm and exit the current menu screen (also use to return to the previous menu with DVDs or to select closed captioning with DTV).

6 ↑/↓/←/→ (TUNE/PRESET) /ENTER

Use the arrow buttons when setting up your surround sound system (see page 77) and the Audio or Video options (page 64 or 67). Also used to control DVD menus/options and for deck 1 of a double cassette deck player. Use **TUNE** ↑/↓ to find radio frequencies and use **PRESET** ←/→ to find preset stations (page 52).

7 Receiver controls

Press **RECEIVER** first to access:

AUTO/ALC/DIRECT – Switches between Auto Surround (page 53), Auto level control mode and Stream Direct mode (page 56).

STEREO – Switches between stereo playback, and Front Stage Surround Advance modes (page 55).

STANDARD – Press for Standard decoding and to switch between the various  Pro Logic IIx and Neo:6 options (page 53).

ADV SURR – Use to switch between the various surround modes (page 54).

8 Component control buttons

The main buttons (▶, ■, etc.) are used to control a component after you have selected it using the input function buttons.

The controls above these buttons can be accessed after you have selected the corresponding input function button (for example **DVD**, **DVR** or **TV**). These buttons also function as described below.

Press **TV** first to access:

ANT – Use to select the VHF/UHF antennas or Cable TV.

Press **TUNER** first to access:

MPX – Switches between stereo and mono reception of FM broadcasts. If the signal is weak, then switching to mono will improve the sound quality (page 51).

Press **RECEIVER** first to access:

PHASE CTRL – Press to switch on/off Phase Control (page 59).

STATUS – Press to check selected receiver settings (page 71).

9 AUDIO – Changes the audio or channel on DVD discs.

DISPLAY – Switches between named station presets and radio frequencies.

CH +/- – Use to select channels for DVD/DVR units.

10 REMOTE SETUP – Use to input the preset code when making remote control settings and to set the remote control mode (page 73).

TV CTRL – Use this button to set preset code of your TV's manufacturer when controlling TV (see *Selecting preset codes directly* on page 73 for more on this).

11 MULTI-ZONE operation selector switch

Switch to perform operations in the main zone and sub zone (page 70).

12 Remote control LED

Lights when a command is sent from the remote control (page 73).

13 SOURCE

Press to turn on/off other components connected to the receiver (see page 73 for more on this).

14 MASTER VOLUME +/-

Use to set the listening volume.

15 MUTE

Mutes the sound or restores the sound if it has been muted (adjusting the volume also restores the sound).

16 RECEIVER

Switches the remote to control the receiver (used to select the white commands above the number buttons (**A.ATT**, etc.)). Also use this button to set up surround sound.

Operating range of remote control unit

The remote control may not work properly if:

- There are obstacles between the remote control and the receiver's remote sensor.
- Direct sunlight or fluorescent light is shining onto the remote sensor.
- The receiver is located near a device that is emitting infrared rays.
- The receiver is operated simultaneously with another infrared remote control unit.

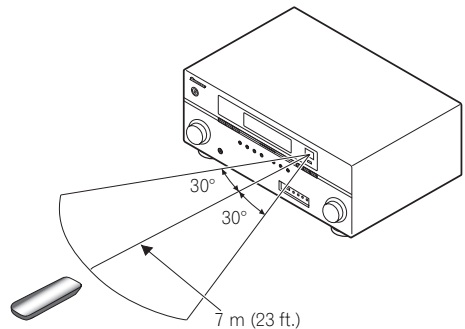

Chapter 3:

Connecting your equipment

This receiver provides you with many connection possibilities, but it doesn't have to be difficult. This page explains the kinds of components you can connect to make up your home theater system.

Rear panel

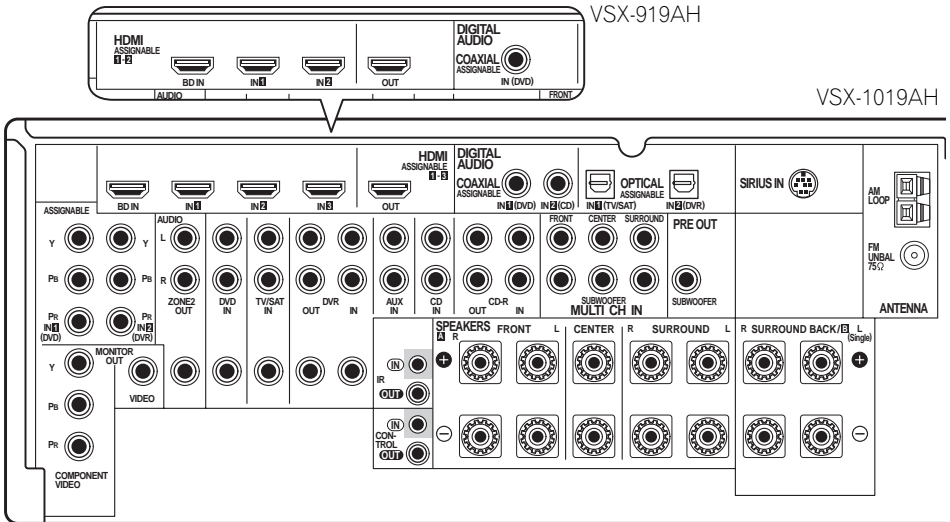

Important

- Illustration shows the VSX-1019AH, however connections for the VSX-919AH are the same except where noted.



CAUTION

- Before making or changing the connections, switch off the power and disconnect the power cord from the power outlet. Plugging in should be the final step.
- To avoid hum, do not lay connected cables over the top of the receiver.

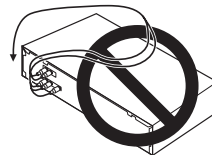

Determining the speakers' application

Surround sound with a strong sense of presence can be enjoyed by connecting 7 speakers and 1 subwoofer. It is also possible to achieve high sound quality using bi-amp connections and to enjoy music in other rooms using the MULTI-ZONE feature. High sound quality can be achieved with a minimum of two speakers.

- Be sure to connect speakers to the front left and right channels (FL and FR).
- The **Surr Back System** setting must be made if you use any of the connections shown below other than [1] (see *Selecting the Surr Back System* on page 21).

[1] 7.1ch surround connection (Simple connection & Best surround)

**Default setting*

These connections prioritize surround sound with a speaker layout like that in a movie theater.

- **Surr Back System setting: Normal** (default)
- If you have six speakers, either only connect one surround back speaker (6.1 ch surround), or connect for the 7.1-channel setting as shown on the diagram below but without the center speaker.

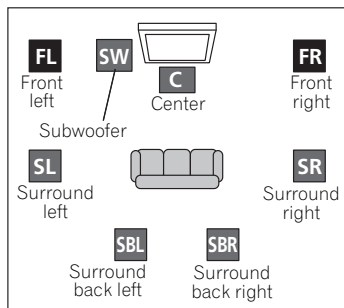

[2] 5.1ch surround & Front Bi-amping connection (High quality surround)

Bi-amping connection of the front speakers for high sound quality with 5.1-channel surround sound.

- **Surr Back System setting: Front Bi-Amp**

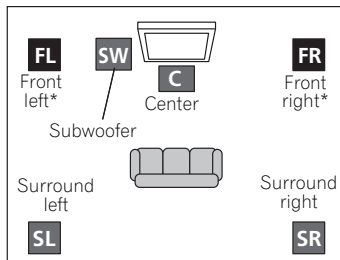

*Bi-amp compatible speaker

[3] 5.1ch surround & Zone 2 connection (Multi Zone)

With these connections you can simultaneously enjoy 5.1-channel surround sound in the main zone with stereo playback on another component in Zone 2. (The selection of input devices is limited.)

- **Surr Back System setting: Zone2**

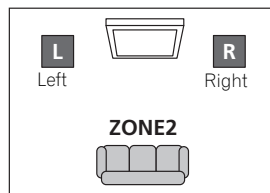
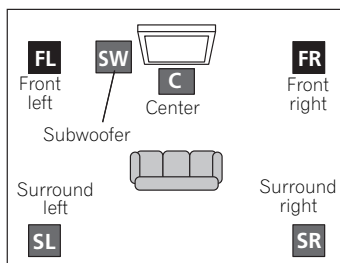

[4] 5.1ch surround & Speaker B connection

With these connections you can simultaneously enjoy 5.1-channel surround sound in the main zone with stereo playback of the same sound on the B speakers.

- **Surr Back System setting: Speaker B**

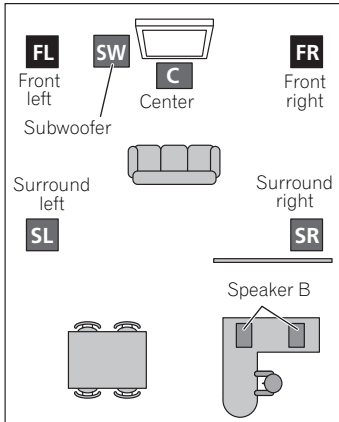
**Other speaker connection**

- Your favorite speaker connections can be selected even if you have fewer than 5.1 speakers.
- When not connecting a subwoofer, connect speakers with low frequency reproduction capabilities to the front channel. (The subwoofer's low frequency component is played from the front speakers, so the speakers could be damaged.)
- **After connecting, be sure to conduct the Auto MCACC (speaker environment setting) procedure** (page 37).

Placing the speakers

To achieve the best possible surround sound, install your speakers as shown below.

5.1 channel surround system:

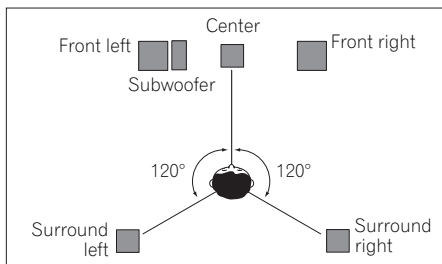

6.1 channel surround system:

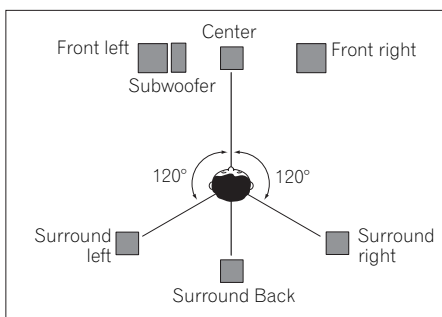

7.1 channel surround system:

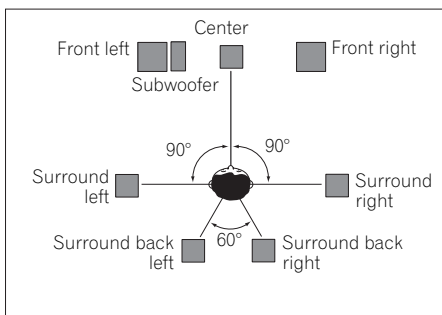

Some tips for improving sound quality

Where you put your speakers in the room has a big effect on the quality of the sound. The following guidelines should help you to get the best sound from your system.

- The subwoofer can be placed on the floor. Ideally, the other speakers should be at about ear-level when you're listening to them. Putting the speakers on the floor (except the subwoofer), or mounting them very high on a wall is not recommended.
- For the best stereo effect, place the front speakers 2 m to 3 m (6 ft. to 9 ft.) apart, at equal distance from the TV.
- If you're using a center speaker, place the front speakers at a wider angle. If not, place them at a narrower angle.
- Place the center speaker above or below the TV so that the sound of the center channel is localized at the TV screen. Also, make sure the center speaker does not cross the line formed by the leading edge of the front left and right speakers.
- It is best to angle the speakers towards the listening position. The angle depends on the size of the room. Use less of an angle for bigger rooms.
- Surround and surround back speakers should be positioned 60 cm to 90 cm (2 ft. to 3 ft.) higher than your ears and tilted slight downward. Make sure the speakers don't face each other. For DVD-Audio, the speakers should be more directly behind the listener than for home theater playback.
- If the surround speakers cannot be set directly to the side of the listening position with a 7.1-channel system, the surround effect can be enhanced by turning off the UP Mix function (see *Setting the Up Mix function* on page 57).
- Try not to place the surround speakers farther away from the listening position than the front and center speakers. Doing so can weaken the surround sound effect.

Connecting the speakers

Each speaker connection on the receiver comprises a positive (+) and negative (–) terminal. Make sure to match these up with the terminals on the speakers themselves.

⚠ CAUTION

- These speaker terminals carry **HAZARDOUS LIVE voltage**. To prevent the risk of electric shock when connecting or disconnecting the speaker cables, disconnect the power cord before touching any uninsulated parts.
- Make sure that all the bare speaker wire is twisted together and inserted fully into the speaker terminal. If any of the bare speaker wire touches the back panel it may cause the power to cut off as a safety measure.

Bare wire connections

- 1 **Twist exposed wire strands together.**
(fig. A)
- 2 **Loosen terminal and insert exposed wire.**
(fig. B)
- 3 **Tighten terminal.** (fig. C)

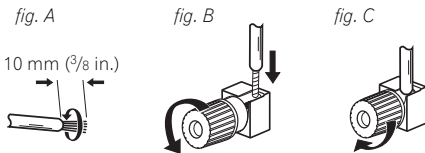

Banana plug connections

If you want to use speaker cables terminated with banana plugs, screw the speaker terminal fully shut, then plug the banana plug into the end of the speaker terminal.

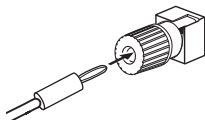

👉 Important

- Please refer to the manual that came with your speakers for details on how to connect the other end of the speaker cables to your speakers.
- Use an RCA cable to connect the subwoofer. It is not possible to connect using speaker cables.

⚠ CAUTION

- Make sure that all speakers are securely installed. This not only improves sound quality, but also reduces the risk of damage or injury resulting from speakers being knocked over or falling in the event of external shocks such as earthquakes.

Installing your speaker system

At the very least, front left and right speakers only are necessary. Note that your main surround speakers should always be connected as a pair, but you can connect just one surround back speaker if you like (it must be connected to the left surround back terminal).

Standard 5.1/6.1/7.1-channel surround connections

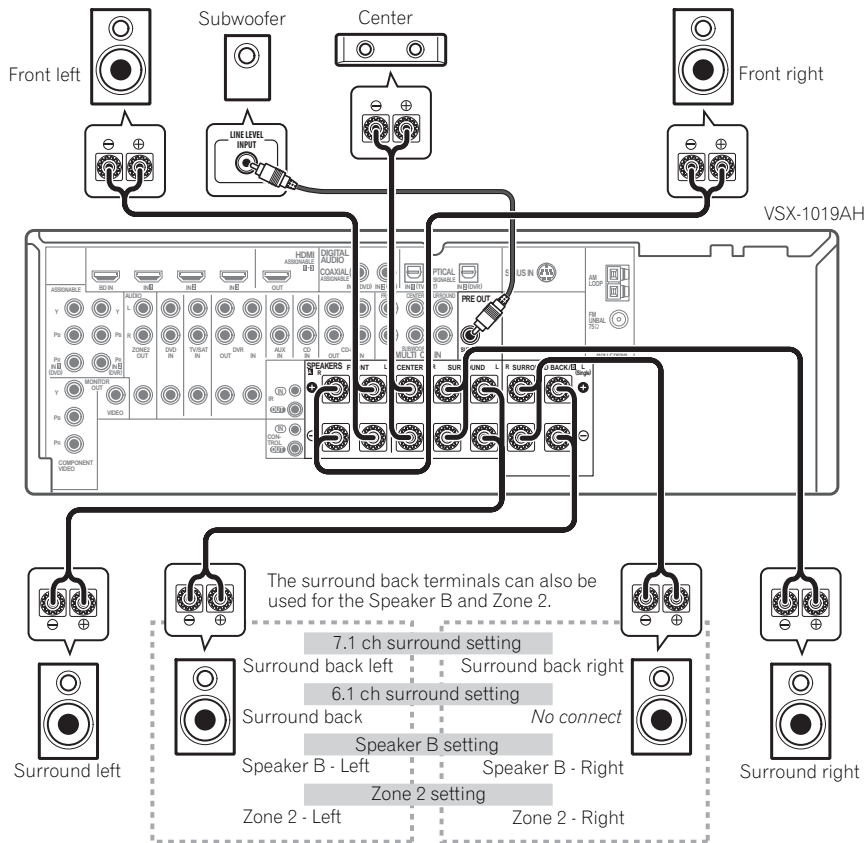

Bi-amping your speakers

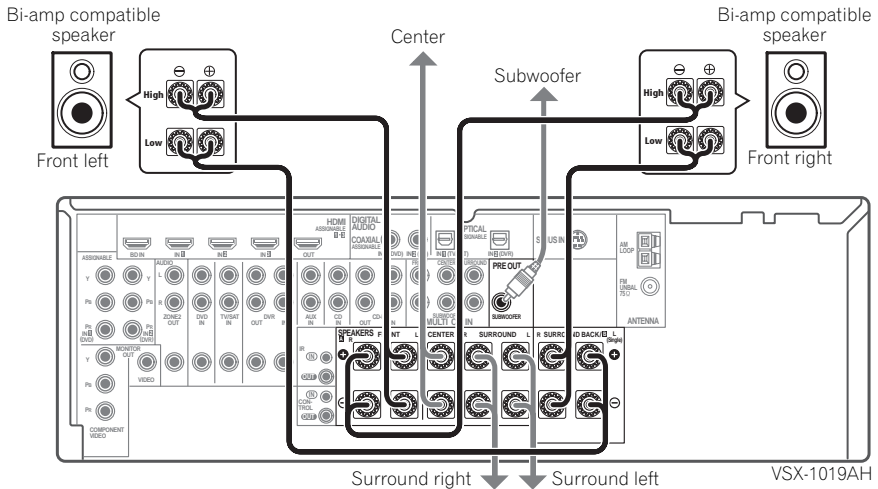

Bi-amping is when you connect the high frequency driver and low frequency driver of your speakers to different amplifiers for better crossover performance. Your speakers must be bi-ampable to do this (having separate terminals for high and low) and the sound improvement will depend on the kind of speakers you're using.

⚠ CAUTION

- Most speakers with both **High** and **Low** terminals have two metal plates that connect the **High** to the **Low** terminals. These must be removed when you are bi-amping the speakers or you could severely damage the amplifier. See your speaker manual for more information.
- If your speakers have a removable crossover network, make sure you do not remove it for bi-amping. Doing so may damage your speakers.

Bi-wiring your speakers

Your speakers can also be bi-wired if they support bi-amping.

- With these connections, the **Surr Back System** setting makes no difference.
- **To bi-wire a speaker, connect two speaker cables to the speaker terminal on the receiver.** Using a banana plug for the second connection is recommended.

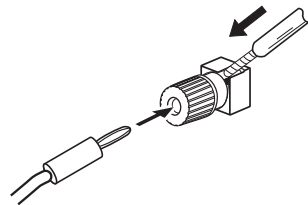

⚠ CAUTION

- Don't connect different speakers from the same terminal in this way.
- When bi-wiring as well, heed the cautions for bi-amping shown at the left.

Selecting the Surr Back system

The surround back terminals can be used for bi-amping, Speaker B and Zone 2 connections, in addition to for the surround back speakers. Make this setting according to the application.

Zone 2 setup

With these connections you can simultaneously enjoy 5.1-channel surround sound in the main zone with stereo playback on another component in Zone 2.

1 Connect a pair of speakers to the surround back speaker terminals.

See *Standard 5.1/6.1/7.1-channel surround connections* on page 19.

2 Select 'ZONE 2' from the Surr Back System menu.

See *Surround back speaker setting* on page 94 to do this.

Speaker B setup

You can listen to stereo playback in another room.

1 Connect a pair of speakers to the surround back speaker terminals.

See *Standard 5.1/6.1/7.1-channel surround connections* on page 19.

2 Select 'Speaker B' from the Surr Back System menu.

See *Surround back speaker setting* on page 94 to do this.

Bi-Amping setup

Bi-amping connection of the front speakers for high sound quality with 5.1-channel surround sound.

1 Connect a Bi-amp compatible speakers to the front and surround back speaker terminals.



See *Bi-amping your speakers* on page 20.

2 Select the 'Front Bi-Amp' setting from the 'Surr Back System' menu.

See *Surround back speaker setting* on page 94 to do this.

About the audio connection

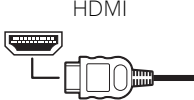
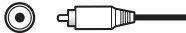
There are several types of audio input and output terminals on this receiver. The receiver selects the first available signal in the following order:

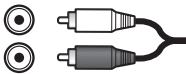
	Types of cables and terminals	Transferable audio signals
↑ Sound signal priority	HDMI 	HD audio
	Digital (Coaxial) 	Conventional digital audio
	Digital (Optical) 	
	RCA (Analog) (White/Red) 	Conventional analog audio

- With an HDMI cable, video and audio signals can be transferred in high quality over a single cable.

⚠ CAUTION

- When connecting optical cables, be careful when inserting the plug not to damage the shutter protecting the optical socket.
- When storing optical cable, coil loosely. The cable may be damaged if bent around sharp corners.

📌 Note

- If the video signal does not appear on your TV or flat panel TV, try adjusting the resolution settings on your component or display. Note that some components (such as video game units) have resolutions that may not be converted. In this case, try switching Digital Video Conversion (in *Setting the Video options* on page 67) **OFF**.
 - The signal input resolutions that can be converted from the component video input for the HDMI output are 480i/576i, 480p/576p, 720p and 1080i. 1080p signals cannot be converted.
 - Only signals with an input resolution of 480i/576i can be converted from the component video input for the composite monitor output.

About the video converter

The video converter ensures that all video sources are output through all of the **MONITOR VIDEO OUT** jacks. The only exception is HDMI: since this resolution cannot be downsampled, you must connect your monitor/TV to the receiver's HDMI video outputs when connecting this video source.¹

If several video components are assigned to the same input function (see *The Input Setup menu* on page 39), the converter gives priority to HDMI, component, then composite (in that order).

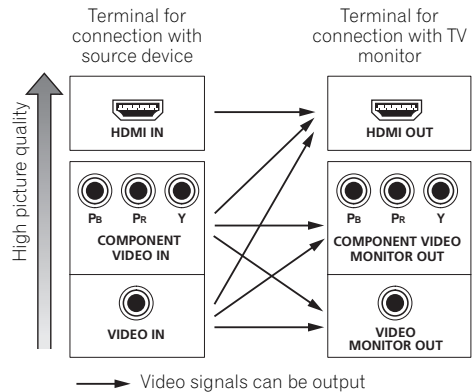

This product incorporates copyright protection technology that is protected by method claims of certain U.S. patents and other intellectual property rights owned by Macrovision Corporation and other rights owners. Use of this copyright protection technology must be authorized by Macrovision Corporation, and is intended for home and other limited viewing uses only unless otherwise authorized by Macrovision Corporation. Reverse engineering or disassembly is prohibited.

Connecting your TV and playback components

Connecting using HDMI

If you have an HDMI or DVI (with HDCP) equipped component (Blu-ray disc player, etc.), you can connect it to this receiver using a commercially available HDMI cable.

If the TV and playback components support the Pioneer KURO LINK feature, the convenient KURO LINK functions can be used (see *KURO LINK* on page 60).

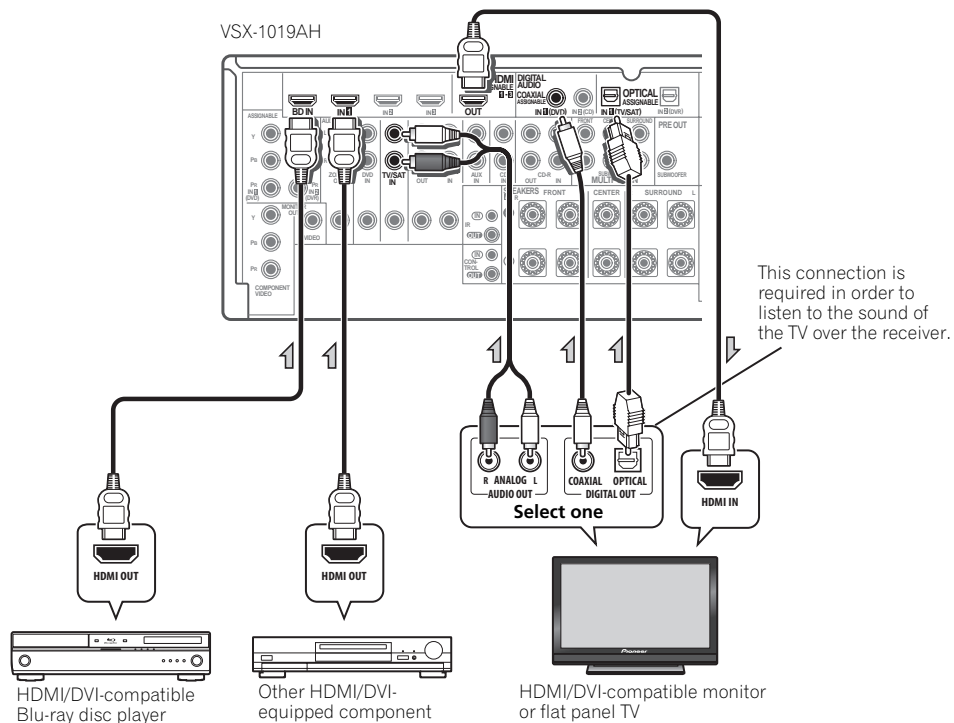

- When connecting a Blu-ray disc player, connect the player to the receiver's **BD IN** terminal.
- The **HDMI** indicator lights on the front panel when an HDMI-equipped component is connected.

- For input components, connections other than HDMI connections are also possible (see *Connecting your DVD player with no HDMI output* on page 25).
- If your Blu-ray disc player offers multi-channel analog audio outputs, see *Connecting the multichannel analog inputs* on page 28.

- The sound of the TV cannot be heard over the receiver if the TV is connected using an HDMI cable.

If you want to listen to the sound of the TV over the receiver, connect the receiver and TV with audio cables.

- Synchronized operation with components using the KURO LINK function (see *KURO LINK* on page 60)

HDMI, the HDMI logo and High-Definition Multimedia Interface are trademarks or registered trademarks of HDMI Licensing, LLC. "x.v.Color" and x.v.Color logo are trademarks of Sony Corporation.

About HDMI¹

The HDMI connection transfers uncompressed digital video, as well as almost every kind of digital audio that the connected component is compatible with, including DVD-Video, DVD-Audio, SACD, Dolby Digital Plus, Dolby TrueHD, DTS-HD Master Audio (see below for limitations), Video CD/Super VCD and CD. See *About the video converter* on page 22 for more on HDMI compatibility.

This receiver incorporates High-Definition Multimedia Interface (HDMI™) technology.

This receiver supports the functions described below through HDMI connections.

- Digital transfer of uncompressed video (contents protected by HDCP (1080p/24, 1080p/60, etc.))
- DeepColor signal transfer²
- x.v.Color signal transfer²
- Input of multi-channel linear PCM digital audio signals (192 kHz or less) for up to 8 channels
- Input of the following digital audio formats:
 - Dolby Digital, Dolby Digital Plus, DTS, High bitrate audio (Dolby TrueHD, DTS-HD Master Audio), DVD-Audio, CD, SACD (DSD signal), Video CD, Super VCD

Note

- 1 • An HDMI connection can only be made with DVI-equipped components compatible with both DVI and High Bandwidth Digital Content Protection (HDCP). If you choose to connect to a DVI connector, you will need a separate adaptor (DVI → HDMI) to do so. A DVI connection, however, does not support audio signals. Consult your local audio dealer for more information.
 - If you connect a component that is not compatible with HDCP, an **HDCP ERROR** message is displayed on the front panel display. Some components that are compatible with HDCP still cause this message to be displayed, but so long as there is no problem with displaying video this is not a malfunction.
 - Depending on the component you have connected, using a DVI connection may result in unreliable signal transfers.
 - This receiver supports SACD, Dolby Digital Plus, Dolby TrueHD and DTS-HD Master Audio. To take advantage of these formats, however, make sure that the component connected to this receiver also supports the corresponding format.
- 2 Signal transfer is only possible when connected to a compatible component.

Connecting your DVD player with no HDMI output

This diagram shows connections of a TV (with HDMI input) and DVD player (or other playback component with no HDMI output) to the receiver.

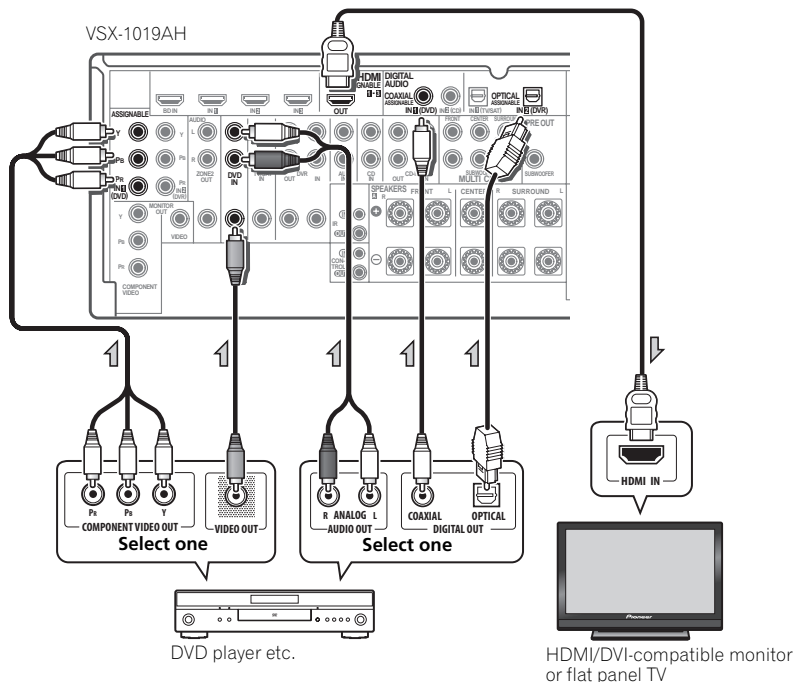

- If you want to listen to the sound of the TV over the receiver, connect the receiver and TV with audio cables.
- Component video should give superior picture quality when compared to composite. You can also take advantage of progressive scan video (if your source and TV are both compatible), which delivers a very stable, flicker-free picture. See the manuals that came with your TV and source component to check whether they are compatible with progressive-scan video.

Connecting your TV with no HDMI input

This diagram shows connections of a TV (with no HDMI input) and DVD player (or other playback component) to the receiver.

- With these connections, the picture is not output to the TV even if the DVD player is connected with an HDMI cable. Connect the DVD player's video signals using a composite or component cord.

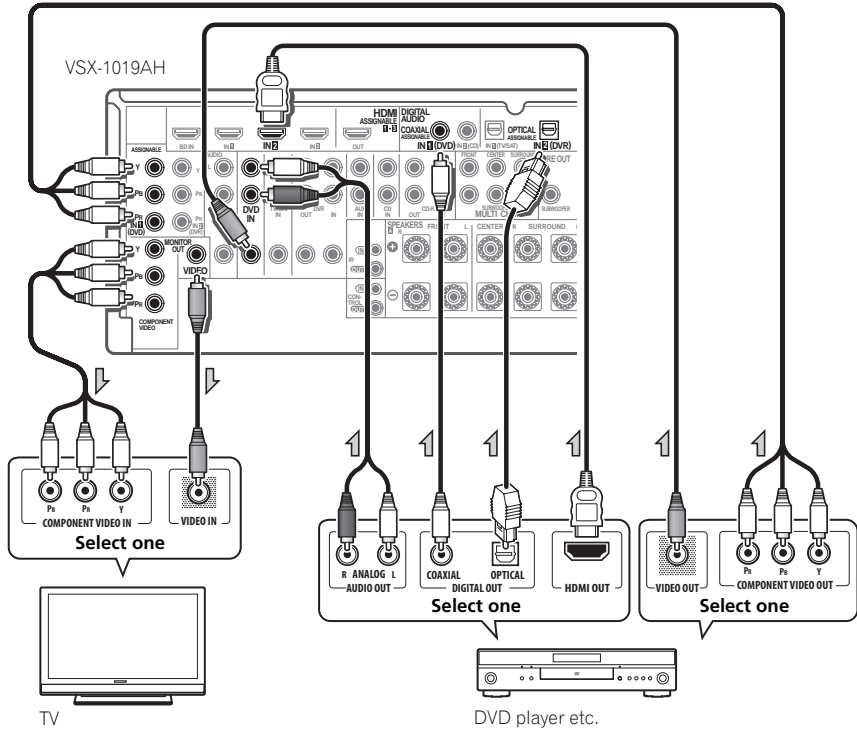

- Connect using an HDMI cable to listen to HD audio on the receiver. Do not use an HDMI cable to input video signals. Depending on the video component, it may not be possible to output signals connected by HDMI and other methods simultaneously, and it may be necessary to make output settings. Please refer to the operating instructions supplied with your component for more information.
- Component video should give superior picture quality when compared to composite. You can also take advantage of progressive scan video (if your source and TV are both compatible), which delivers a very stable, flicker-free picture. See the manuals that came with your TV and source component to check whether they are compatible with progressive-scan video.

- If your DVD player has multichannel analog outputs, you can connect these instead. See also see *Connecting the multichannel analog inputs* on page 28.
- The input functions below are assigned by default to the receiver's different input terminals. Refer to *The Input Setup menu* on page 39 to change the assignments if other connections are used. For example, the BD terminal is fixed to **BD** input; no other audio signals can be input to this terminal.

Input function	Input Terminals		
	Digital	HDMI	Component
DVD	COAX-1 ^a /COAX ^b		IN 1
BD		(BD)	
TV/SAT	OPT-1		
DVR	OPT-2		IN 2
HDMI 1		(HDMI-1)	
HDMI 2		(HDMI-2)	
HDMI 3 ^a		(HDMI-3)	
CD	COAX-2 ^a		

a.VSX-1019AH model only.
b.VSX-919AH model only.

Connecting a satellite/cable receiver or other set-top box

Satellite and cable receivers, and terrestrial digital TV tuners are all examples of so-called 'set-top boxes'.

When you set up the receiver you'll need to tell the receiver which input you connected the set-top box to (see *The Input Setup menu* on page 39).

VSX-1019AH

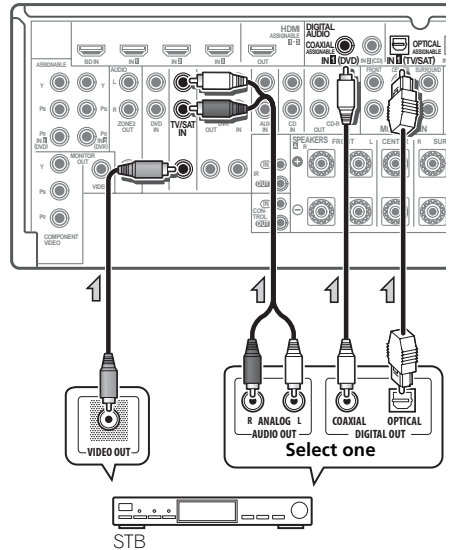

Connecting a HDD/DVD recorder, VCR and other video sources

This receiver has two sets of audio/video inputs and outputs suitable for connecting analog or digital video devices, including HDD/DVD recorders and VCRs.

When you set up the receiver you'll need to tell the receiver which input you connected the recorder to (see also *The Input Setup menu* on page 39).

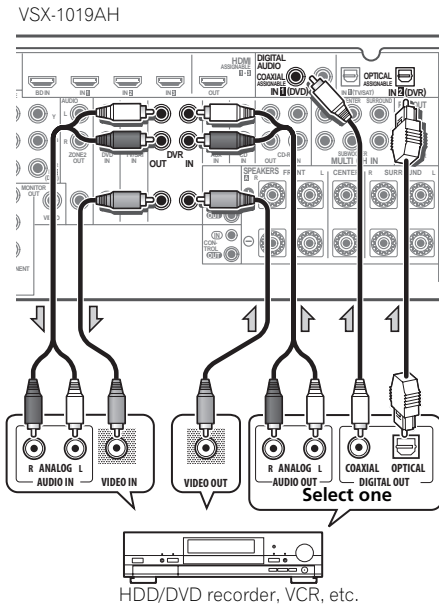

- In order to record, you must connect the analog audio cables (the digital connection is for playback only).

Connecting the multichannel analog inputs

For DVD Audio and SACD playback, your DVD player may have 5.1 channel analog outputs. Make sure that the player is set to output multichannel analog audio.

VSX-1019AH

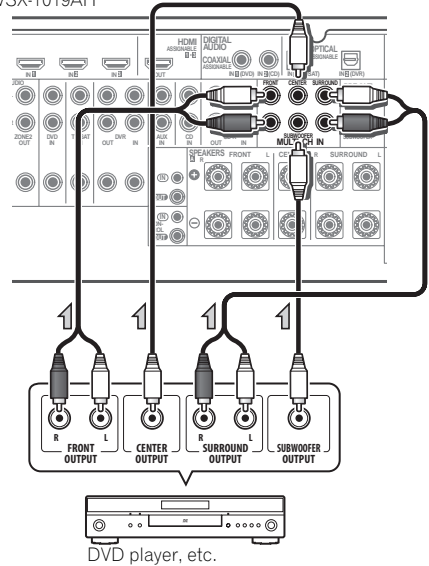

- If your player has 7.1-channel analog outputs, the player's surround back output terminals are not used. Please refer to the operating instructions supplied with your component for more information.

Connecting other audio components

This receiver has both digital and analog inputs, allowing you to connect audio components for playback.

This receiver features five stereo audio-only inputs. One of these inputs have corresponding outputs for use with audio recorders.

Most digital components also have analog connections.

When you set up the receiver you'll need to tell the receiver which input you connected the component to (see also *The Input Setup menu* on page 39).

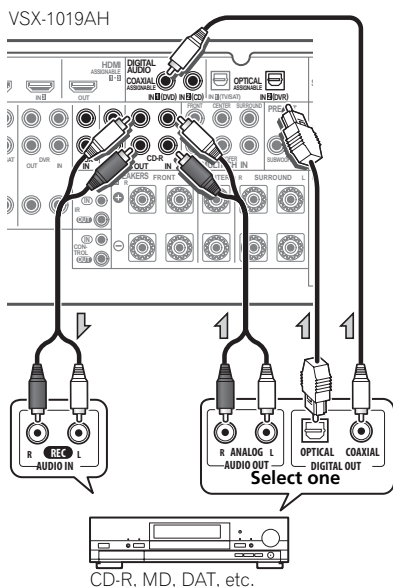

- If your turntable has line-level outputs (i.e., it has a built-in phono pre-amp), connect it to the **CD** inputs instead.
- If you're connecting a recorder, connect the analog audio outputs to the analog audio inputs on the recorder.

About the WMA9 Pro decoder

This unit has an on-board Windows Media™ Audio 9 Professional¹ (WMA9 Pro) decoder, so it is possible to playback WMA9 Pro-encoded audio using HDMI, coaxial or optical digital connection when connected to a WMA9 Pro-compatible player. However, the connected DVD player, set-top box, etc. must be able to output WMA9 Pro format audio signals through a coaxial or optical digital output.

Note

- ¹ • Windows Media and the Windows logo are trademarks or registered trademarks of Microsoft Corporation in the United States and/or other countries.
 - With WMA9 Pro, sound problems may occur depending on your computer system. Note that WMA9 Pro 96 kHz sources will be downsampled to 48 kHz.

Connecting AM/FM antennas

Connect the AM loop antenna and the FM wire antenna as shown below. To improve reception and sound quality, connect external antennas (see *Connecting external antennas* below).

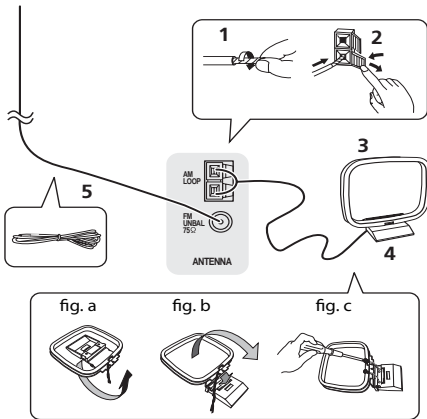

1 Pull off the protective shields of both AM antenna wires.

2 Push open the tabs, then insert one wire fully into each terminal, then release the tabs to secure the AM antenna wires.

3 Fix the AM loop antenna to the attached stand.

To fix the stand to the antenna, bend in the direction indicated by the arrow (*fig. a*) then clip the loop onto the stand (*fig. b*).

- If you plan to mount the AM antenna to a wall or other surface, secure the stand with screws (*fig. c*) before clipping the loop to the stand. Make sure the reception is clear.

4 Place the AM antenna on a flat surface and in a direction giving the best reception.

5 Connect the FM wire antenna in the same way as the AM loop antenna.

For best results, extend the FM antenna fully and fix to a wall or door frame. Don't drape loosely or leave coiled up.

Connecting external antennas

To improve FM reception connect an external FM antenna to the **FM UNBAL 75 Ω**.

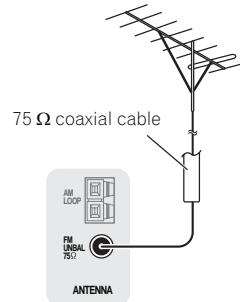

To improve AM reception, connect a 5 m to 6 m (16 ft. to 20 ft.) length of vinyl-coated wire to the **AM LOOP** terminals without disconnecting the supplied AM loop antenna.

For the best possible reception, suspend horizontally outdoors.

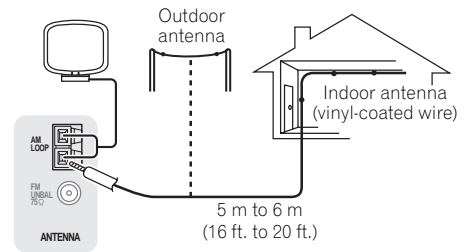

MULTI-ZONE setup

This receiver can power up to two independent systems in separate rooms after you have made the proper MULTI-ZONE connections.

Different sources can be playing in two zones at the same time or, depending on your needs, the same source can also be used. The main and sub zone have independent power (the main zone power can be off while sub zone is on) and the sub zone can be controlled by the remote or front panel controls. However, you may need to specify the volume settings in *ZONE Audio Setup* on page 99.

Making MULTI-ZONE connections

It is possible to make these connections if you have a separate TV and speakers for the sub zone (**ZONE2**). You will also need a separate amplifier if you are not using the *MULTI-ZONE setup using speaker terminals (Zone 2)* below for the sub zone.

MULTI-ZONE listening options

The following table shows the signals that can be output to ZONE 2:

Sub Zone	Input functions available
ZONE2	Analog audio signals (AUDIO ZONE2 OUT). ^a With video signals, ^b the composite video (VIDEO ZONE2 OUT) signals can be output.

a. Any analog signal. (This does not apply for the MULTI CH IN input.)

b. JPEG files cannot be played with the USB input.

Basic MULTI-ZONE setup (Zone 2)

• **Connect a separate amplifier to the AUDIO ZONE2 OUT jacks and a TV monitor to the VIDEO ZONE2 OUT jack, both on this receiver.** You should have a pair of speakers attached to the sub zone amplifier as shown in the following illustration.

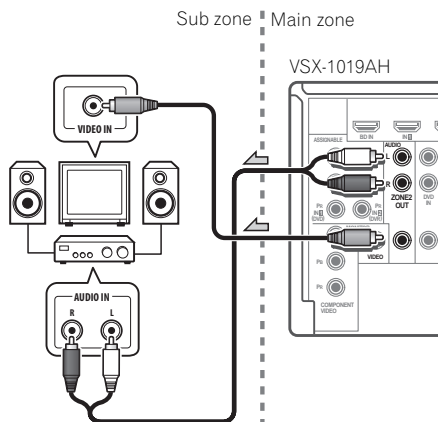

MULTI-ZONE setup using speaker terminals (Zone 2)

You must select **ZONE 2** in *Surround back speaker setting* on page 94 to use this setup. Note that the sound in the sub zone will be temporarily interrupted when controlling the main zone (for example, changing the input function or starting playback).

- **Connect a TV monitor to the VIDEO ZONE2 OUT jacks on this receiver.**

You should have a pair of speakers attached to the surround back speaker terminals as shown below.

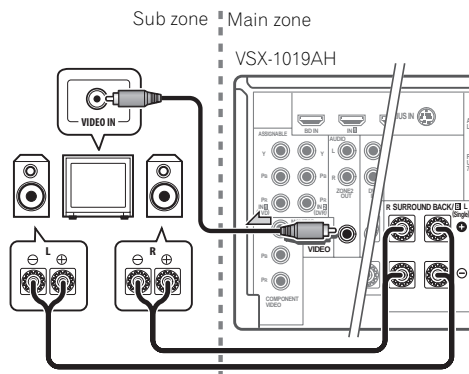

Connecting an IR receiver

If you keep your stereo components in a closed cabinet or shelving unit, or you wish to use the sub zone remote control in another zone, you can use an optional IR receiver (such as a Niles or Xantech unit) to control your system instead of the remote sensor on the front panel of this receiver.¹

1 Connect the IR receiver sensor to the IR IN jack on the rear of this receiver.

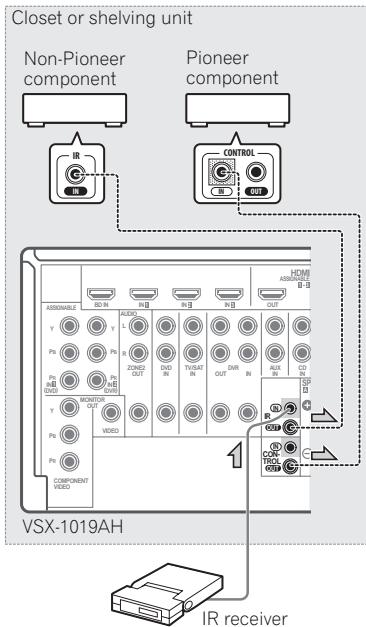

2 Connect the IR IN jack of another component to the IR OUT jack on the rear of this receiver to link it to the IR receiver.

Please see the manual supplied with your IR receiver for the type of cable necessary for the connection.

- If you want to link a Pioneer component to the IR receiver, see *Operating other Pioneer components with this unit's sensor* below to connect to the **CONTROL** jacks instead of the **IR OUT** jack.

Operating other Pioneer components with this unit's sensor

Many Pioneer components have **SR CONTROL** jacks which can be used to link components together so that you can use just the remote sensor of one component. When you use a remote control, the control signal is passed along the chain to the appropriate component.²



Important

- Note that if you use this feature, *make sure that you also have at least one set of analog audio, video or HDMI jacks connected to another component for grounding purposes.*

1 Decide which component you want to use the remote sensor of.

When you want to control any component in the chain, this is the remote sensor at which you'll point the corresponding remote control.

Note

- Remote operation may not be possible if direct light from a strong fluorescent lamp is shining on the IR receiver remote sensor window.
 - Note that other manufacturers may not use the IR terminology. Refer to the manual that came with your component to check for IR compatibility.
 - If using two remote controls (at the same time), the IR receiver's remote sensor takes priority over the remote sensor on the front panel.
- If you want to control all your components using this receiver's remote control, see *Setting the remote to control other components* on page 73.
 - If you have connected a remote control to the **CONTROL IN** jack (using a mini-plug cable), you won't be able to control this unit using the remote sensor.

2 Connect the CONTROL OUT jack of that component to the CONTROL IN jack of another Pioneer component.

Use a cable with a mono mini-plug on each end for the connection.

VSX-1019AH

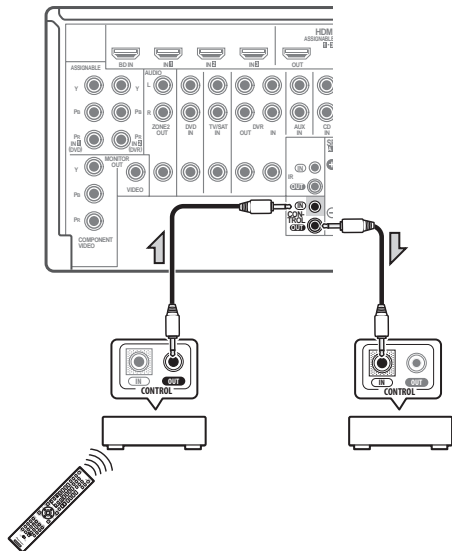

Continue the chain in the same way for as many components as you have.

Connecting your SiriusConnect™ Tuner

To receive SIRIUS Satellite Radio broadcasts, you will need to activate your SiriusConnect™ tuner.

VSX-1019AH

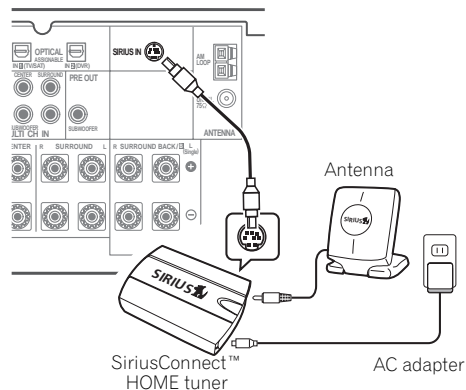

- **Connect a SiriusConnect™ tuner to the SIRIUS IN jack on the rear of this receiver.** You will also need to connect the antenna and AC adapter to the SiriusConnect™ tuner.

Connecting a component to the front panel inputs

The front panel inputs comprise a composite video jack (**VIDEO**) and stereo analog audio inputs (**AUDIO L/R**). You can use these connections for any kind of audio/video component, but they are especially convenient for portable equipment such as camcorders, video games and portable audio/video equipment.

- Push down on the **PUSH OPEN** tab to access the front panel inputs.
- Select these inputs using **INPUT SELECT** (remote) or the **INPUT SELECTOR** dial (front panel) to select **VIDEO**.

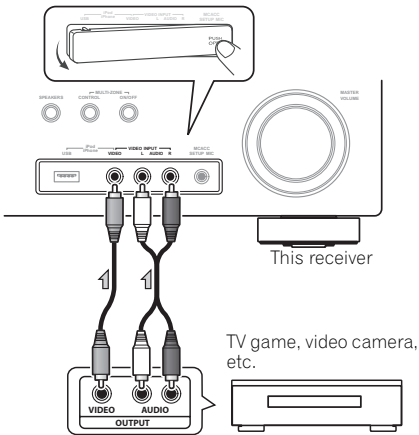

Connecting an iPod

This receiver has a dedicated iPod terminal that will allow you to control playback of audio content from your iPod using the controls of this receiver.

- **Switch the receiver into standby then use the supplied iPod cable to connect your iPod to the iPod/iPhone/USB terminal on the front panel of this receiver.**
 - Push down on the **PUSH OPEN** tab to access the **iPod/iPhone/USB** terminal.
 - It is also possible to connect using the cable included with the iPod, but in this case it is not possible to view pictures via the receiver.
 - For the cable connection, refer to also the operating instructions for iPod.

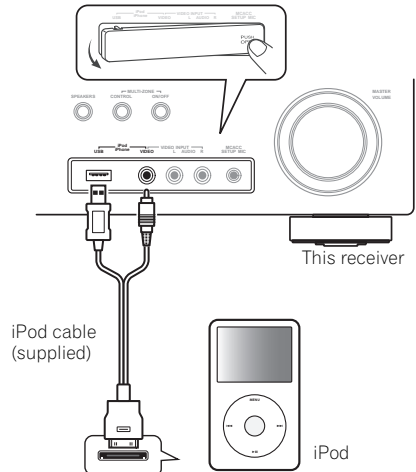

Connecting a USB device

It is possible to playback files using the USB interface on the front of this receiver.

- Switch the receiver into standby then connect your USB device to the iPod/iPhone/USB terminal on the front panel of this receiver.

- Push down on the **PUSH OPEN** tab to access the iPod/iPhone/USB terminal.

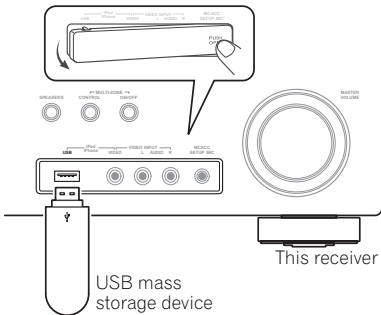

Plugging in the receiver

Only plug in after you have connected all your components to this receiver, including the speakers.

- Plug the AC power cord into a convenient AC power outlet.¹

⚠ CAUTION

- Handle the power cord by the plug part. Do not pull out the plug by tugging the cord, and never touch the power cord when your hands are wet, as this could cause a short circuit or electric shock. Do not place the unit, a piece of furniture, or other object on the power cord or pinch the cord in any other way. Never make a knot in the cord or tie it with other cables. The power cords should be routed so that they are not likely to be stepped on. A damaged power cord can cause a fire or give you an electric shock. Check the power cord once in a while. If you find it damaged, ask your nearest Pioneer authorized independent service company for a replacement.
- The receiver should be disconnected by removing the mains plug from the wall socket when not in regular use, e.g., when on vacation.
- Make sure the blue **STANDBY/ON** light has gone out before unplugging.
- If you have connected speakers with a 6 Ω impedance, change the impedance setting before turning on the power.

📌 Note

¹ After this receiver is connected to an AC outlet, a 2 second to 10 second HDMI initialization process begins. You cannot carry out any operations during this process. The **HDMI** indicator in the front panel display blinks during this process, and you can turn on this receiver once it has stopped blinking. When you set the **KURO LINK** mode to **OFF**, you can skip this process. For details about the **KURO LINK** feature, see *KURO LINK* on page 60.

Chapter 4: Basic Setup

Switching the speaker impedance

We recommend using speakers of 8 Ω with this system, but it is possible to switch the impedance setting if you plan to use speakers with a 6 Ω impedance rating.

1 Switch the receiver into standby.

2 While holding down ENTER on the front panel, press \odot STANDBY/ON.

The display shows **RESET ◀ NO ▶**.

Use **TUNE +/-** (or \uparrow/\downarrow on the remote control) to select **SPEAKER ◀ 8 Ω ▶**, and then use **PRESET +/-** (or \leftarrow/\rightarrow on the remote control) to select **SPEAKER 8 Ω** or **SPEAKER 6 Ω** .

- **SPEAKER 8 Ω** – Use this setting if your speakers are rated at 8 Ω or more.
- **SPEAKER 6 Ω** – Use this setting if your speakers are rated at 6 Ω .

Changing the OSD display language (OSD Language)

The language used on the on-screen display can be changed.

- The explanations in these operating instructions are for when English is selected for the OSD.

1 Press **RECEIVER** on the remote control, then press **HOME MENU**.

A Graphical User Interface (GUI) screen appears on your TV. Use $\uparrow/\downarrow/\leftarrow/\rightarrow$ and **ENTER** to navigate through the screens and select menu items. Press **RETURN** to exit the current menu.

2 Select 'System Setup' from the HOME MENU.

3 Select 'OSD Language' from the System Setup menu.

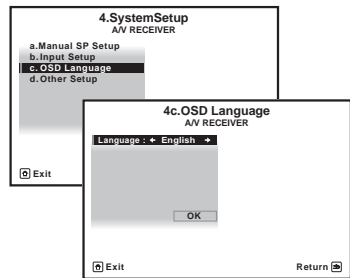

4 Select the desired language.

- English
- French
- German
- Italian
- Spanish
- Dutch
- Russian

5 Select 'OK' to change the language.

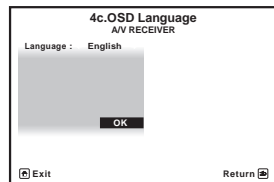

The setting is completed and the **System Setup** menu reappears automatically.

Automatically setting up for surround sound (Auto MCACC)

The Auto MCACC Setup measures the acoustic characteristics of your listening area, taking into account ambient noise, speaker connection and speaker size, and tests for both channel delay and channel level. After you have set up the microphone provided with your system, the receiver uses the information from a series of test tones to optimize the speaker settings and equalization for your particular room.

Make sure you do this before moving on to *Playing a source* on page 41.

Important

- Make sure the microphone and speakers are not moved during the Auto MCACC Setup.
- Using the Auto MCACC Setup will overwrite any existing settings for the MCACC preset you select.
- Before using the Auto MCACC Setup, the headphones should be disconnected and the iPod/USB or SIRIUS Radio function should not be selected as an input function.

CAUTION

- The test tones used in the Auto MCACC Setup are output at high volume.

Note

- You can't use the **HOME MENU** when the iPod/USB or SIRIUS Radio input function is selected (in either the main or sub zone). When you set **ZONE 2** to **ON** (page 69), you can't use the **HOME MENU**.
 - If you leave the GUI screen for over five minutes, the screen saver will appear.
- If you are planning on bi-amping your front speakers, or setting up a separate speaker system in another room, read through *Surround back speaker setting* on page 94 and make sure to connect your speakers as necessary before continuing to step 4.
- If you have THX-certified speakers, select **Return**, then select **Auto MCACC** for the THX Speaker setting. See *Automatic MCACC (Expert)* on page 78 for more on this.
- The six MCACC presets are used for storing surround sound settings for different listening positions. Simply choose an unused preset for now (you can rename it later in *Data Management* on page 91).
- Note that correction curves are saved only when set to **SYMMETRY**. Select **Return**, then select **Auto MCACC** to save other correction curves (such as **ALL CH ADJ** and **FRONT ALIGN**). See *Automatic MCACC (Expert)* on page 78 for more on this.

- 1 Switch on the receiver and your TV.
- 2 Connect the microphone to the MCACC SETUP MIC jack on the front panel.
 - Push down on the **PUSH OPEN** tab to access the **MCACC SETUP MIC** jack.

Place the microphone so that it's about ear level at your normal listening position (use a tripod if possible). Make sure there are no obstacles between the speakers and the microphone.

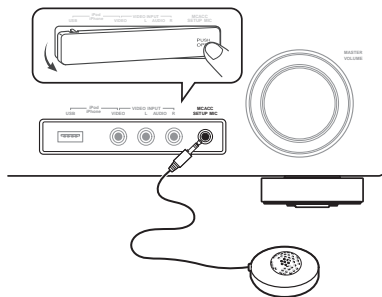

The Full Auto MCACC display appears once the microphone is connected.¹

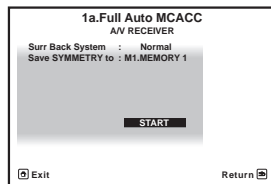

- 3 Select **Surr Back System** setting,² select an MCACC preset³, press **RECEIVER** and then select **START**.⁴

Select **Normal** (Surround back), **Speaker B**, **Front Bi-Amp** or **ZONE 2** for the **Surr Back System** setting according to connections to the surround back speaker terminals.

4 Follow the instructions on-screen.

Make sure the microphone is connected, and if you're using a subwoofer, make sure it is switched on and set to a comfortable volume level.

5 Wait for the test tones to finish, then confirm the speaker configuration in the GUI screen.

A progress report is displayed on-screen while the receiver outputs test tones to determine the speakers present in your setup. Try to be as quiet as possible while it's doing this.¹

If no operations are performed for 10 seconds while the speaker configuration check screen is being displayed, the Auto MCACC Setup will resume automatically. In this case, you don't need to select **'OK'** and press **ENTER** in step 6.

- With error messages (such as **Too much ambient noise!** or **Check microphone.**) select **RETRY** after checking for ambient noise (see *Problems when using the Auto MCACC Setup* below) and verifying the mic connection. If there doesn't seem to be a problem, you can simply select **GO NEXT** and continue.

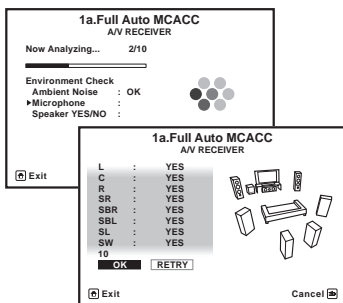

The configuration shown on-screen should reflect the actual speakers you have.

- If you see an **ERR** message (or the speaker configuration displayed isn't correct), there may be a problem with the speaker connection.

If selecting **RETRY** doesn't work, turn off the power and check the speaker connections. If there doesn't seem to be a problem, you can simply use **↑/↓** to select the speaker and **←/→** to change the setting and continue.

- If **Reverse Phase** is displayed, the speaker's wiring (+ and -) may be inverted. Check the speaker connections.² If the connections were wrong, turn off the power, disconnect the power cable, then reconnect properly. After this, perform the Full Auto MCACC procedure again.

6 Make sure 'OK' is selected, then press ENTER.

A progress report is displayed on-screen while the receiver outputs more test tones to determine the optimum receiver settings for Channel Level, Speaker Distance, Standing Wave and Acoustic Cal EQ.

Again, try to be as quiet as possible while this is happening. It may take 3 to 10 minutes.

Note

- 1 Do not adjust the volume during the test tones. This may result in incorrect speaker settings.
- 2 If the speaker is not pointed to the microphone (listening position) or when using speakers that affect the phase (dipole speakers, reflective speakers, etc.), **Reverse Phase** may be displayed even if the speakers are properly connected. If this happens, select **GO NEXT** and continue.

7 The Auto MCACC Setup procedure is completed and the Home Menu menu reappears automatically.¹

Be sure to disconnect the microphone from this receiver upon completion of the Auto MCACC Setup.

The settings made in the Auto MCACC Setup should give you excellent surround sound from your system, but it is also possible to adjust these settings manually using *The Advanced MCACC menu* on page 77 or *The system and the other setup* on page 93.²

Problems when using the Auto MCACC Setup

If the room environment is not optimal for the Auto MCACC Setup (too much background noise, echo off the walls, obstacles blocking the speakers from the microphone) the final settings may be incorrect. Check for household appliances (air conditioner, fridge, fan, etc.), that may be affecting the environment and switch them off if necessary. If there are any instructions showing in the front panel display, please follow them.

- Some older TVs may interfere with the operation of the microphone. If this seems to be happening, switch off the TV when doing the Auto MCACC Setup.

The Input Setup menu

You only need to make settings in the **Input Setup** menu if you didn't hook up your digital equipment according to the default settings (see *Input function default and possible settings* on page 40). In this case, you need to

Note

- ¹ You can also choose to view the settings from the **MCACC Data Check** screen. See *Checking MCACC Data* on page 89 for more on this.
- ² Depending on the characteristics of your room, sometimes identical speakers with cone sizes of around 12 cm (5 inches) will end up with different size settings. You can correct the setting manually using the *Manual speaker setup* on page 94.
 - The subwoofer distance setting may be farther than the actual distance from the listening position. This setting should be accurate (taking delay and room characteristics into account) and generally does not need to be changed.
 - If Auto MCACC Setup measurement results are incorrect due to the interaction of the speakers and viewing environment, we recommend adjusting the settings manually.

tell the receiver what equipment is hooked up to which terminal so the buttons on the remote control correspond to the components you've connected.

1 Switch on the receiver and your TV.

Use **RECEIVER** to switch on.

2 Press **RECEIVER** on the remote control, then press **HOME MENU**.

A Graphical User Interface (GUI) screen appears on your TV. Use **↑/↓/←/→** and **ENTER** to navigate through the screens and select menu items. Press **RETURN** to confirm and exit the current menu.

3 Select 'System Setup' from the HOME MENU.

4 Select 'Input Setup' from the System Setup menu.

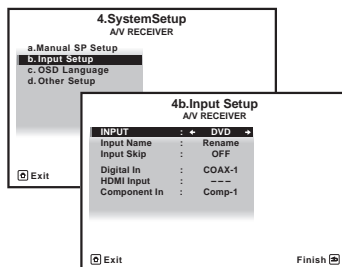

5 Select the input function that you want to set up.

The default names correspond with the names next to the terminals on the rear panel (such as **DVD** or **VIDEO**) which, in turn, correspond with the names on the remote control.

6 Select the input(s) to which you've connected your component.

For example, if your DVD player only has an optical output, you will need to change the **DVD** input function's **Digital In** setting from **COAX-1** (*VSX-1019AH model*)/**COAX** (*VSX-919AH model*) (default) to the optical input you've connected it to. The numbering (**OPT-1** to **2**) corresponds with the numbers beside the inputs on the back of the receiver.

- If your component is connected via a component video cable to an input terminal other than the default, you must tell the receiver which input terminal your component is connected to, or else you may see the composite video signals instead of the component video signals.¹

7 When you're finished, proceed to the settings for other inputs.

There are three optional settings in addition to the assignment of the input jacks:

- Input Name** – You can choose to rename the input function for easier identification. Select **Rename** to do so, or **Default** to return to the system default.
- Input Skip** – When set to **ON**, that input is skipped when selecting the input using **INPUT SELECT**. (**DVD** and other inputs can be still be selected directly with the input function buttons.)

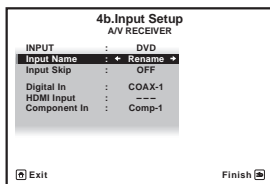

8 When you're finished, press RETURN.

You will return to the **System Setup** menu.

Input function default and possible settings

The terminals on the receiver generally correspond to the name of one of the input functions. If you have connected components to this receiver differently from (or in addition to) the defaults below, see *The Input Setup menu* on page 39 to tell the receiver how you've connected up. The dots (●) indicate possible assignments.

Input function	Input Terminals		
	Digital	HDMI	Component
DVD	COAX-1 ^a /COAX ^b	● ^c	IN 1
BD		(BD)	
TV/SAT	OPT-1	● ^c	●
DVR	OPT-2	● ^c	IN 2
VIDEO			
HDMI 1		(HDMI-1)	
HDMI 2		(HDMI-2)	
HDMI 3 ^a		(HDMI-3)	
iPod/USB			
CD	COAX-2 ^a		
CD-R/TAPE	●		
TUNER			
AUX	●		
MULTI CH IN		● ^c	
SIRIUS	●		

a. VSX-1019AH model only.

b. VSX-919AH model only.

c. With **KURO LINK** set to **ON**, assignments cannot be made (see *KURO LINK* on page 60).

Note

¹ For high-definition video (using component video connections), or when digital video conversion is switched off (in *Setting the Video options* on page 67), you must connect your TV to this receiver using the same type of video cable as you used to connect your video component.

Chapter 5:

Basic playback

Playing a source

Here are the basic instructions for playing a source (such as a DVD disc) with your home theater system.

1 Switch on your system components and receiver.

Start by switching on the playback component (for example a DVD player), your TV¹ and subwoofer (if you have one), then the receiver (press **RECEIVER**).

- Make sure the setup microphone is disconnected.

2 Select the input function you want to play.

You can use the input function buttons on the remote control, **INPUT SELECT**, or the front panel **INPUT SELECTOR** dial.²

3 Press **AUTO/ALC/DIRECT (AUTO SURR/ALC/STREAM DIRECT)** to select 'AUTO SURROUND' and start playback of the source.³

If you're playing a Dolby Digital or DTS surround sound DVD disc, you should hear surround sound. If you are playing a stereo source, you will only hear sound from the front left/right speakers in the default listening mode.

- See also *Listening to your system* on page 53 for information on different ways of listening to sources.

Note

¹ Make sure that the TV's video input is set to this receiver (for example, if you connected this receiver to the **VIDEO** jacks on your TV, make sure that the **VIDEO** input is now selected).

² If you need to manually switch the input signal type press **SIGNAL SEL** (page 58).

³ You may need to check the digital audio output settings on your DVD player or digital satellite receiver. It should be set to output Dolby Digital, DTS and 88.2 kHz / 96 kHz PCM (2 channel) audio, and if there is an MPEG audio option, set this to convert the MPEG audio to PCM.

- Depending on your DVD player or source discs, you may only get digital 2 channel stereo and analog sound. In this case, the receiver must be set to a multichannel listening mode (see *Listening in surround sound* on page 53 if you need to do this) if you want multichannel surround sound.

It is possible to check on the front panel display whether or not multi-channel playback is being performed properly.

When using a surround back speaker, **DOD+PLIIX MOVIE** is displayed when playing Dolby Digital signals, and **DTS+Neo:6** is displayed when playing DTS 5.1-channel signals.

When not using a surround back speaker, **DOLBY DIGITAL** is displayed when playing Dolby Digital signals.

If the display does not correspond to the input signal and listening mode, check the connections and settings.

4 Use the volume control to adjust the volume level.

Turn down the volume of your TV so that all sound is coming from the speakers connected to this receiver.

Playing a source with HDMI connection

- Use **INPUT SELECT** to select the **HDMI input you've connected to (for example, HDMI 1)**.

You can also perform the same operation by using the **INPUT SELECTOR** dial on the front panel or by pressing **HDMI** on the remote control repeatedly.

- Set the HDMI parameter in *Setting the Audio options* on page 64 to **THROUGH** if you want to hear HDMI audio output from your TV or flat panel TV (no sound will be heard from this receiver).
- If the video signal does not appear on your TV or flat panel TV, try adjusting the resolution settings on your component or display. Note that some components (such as video game units) have resolutions that may not be converted. In this case, use an analog video connection.

Selecting the multichannel analog inputs

If you have connected a decoder or a DVD player as above, you must select the analog multichannel inputs for surround sound playback.¹

1 Make sure you have set the playback source to the proper output setting.

For example, you might need to set your DVD player to output multichannel analog audio.

2 Use **INPUT SELECT** to select **MULTI CH IN**.

You can also use the **INPUT SELECTOR** dial on the front panel.

- Depending on the DVD player you're using, the analog output level of the subwoofer channel may be too low. In this case, the output level of the subwoofer can be increased by 10 dB in the **Multi Ch In Setup** in **Other Setup**. For details, see *Multi Channel Input Setup* on page 99.

Note

- 1 • When playback from the multichannel inputs is selected, only the volume and channel levels can be set.
 - You can't listen to your speaker B system during playback from the multichannel inputs.
 - With **MULTI CH IN** inputs, it is possible to play pictures simultaneously. For details, see *Multi Channel Input Setup* on page 99.

Playing an iPod

This receiver has a dedicated iPod terminal that will allow you to control playback of audio content from your iPod using the controls of this receiver.¹

1 Switch on the receiver and your TV.

See *Connecting an iPod* on page 34.

2 Press iPod USB on the remote control to switch the receiver to the iPod/USB.

Loading appears in the GUI screen while the receiver verifies the connection and retrieves data from the iPod.

When the display shows **iPod** top menu you're ready to play music from the iPod.²

- *Main Zone:*

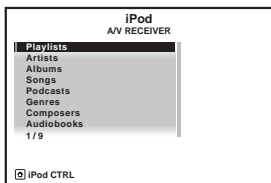

- *Sub Zone (VSX-1019AH model only):*



Playing back audio files stored on an iPod

To navigate songs on your iPod, you can take advantage of the GUI screen of your TV connected to this receiver.³ You can also control all operations for music in the front panel display of this receiver.

Finding what you want to play

When your iPod is connected to this receiver, you can browse songs stored on your iPod by playlist, artist name, album name, song name, genre or composer, similar to using your iPod directly.

1 Use ↑/↓ to select a category, then press ENTER to browse that category.

- To return to the previous level any time, press **RETURN**.

2 Use ↑/↓ to browse the selected category (e.g., albums).

- Use ←/→ to move to previous/next levels.

3 Continue browsing until you arrive at what you want to play, then press ► to start playback.⁴

- *Main Zone:*

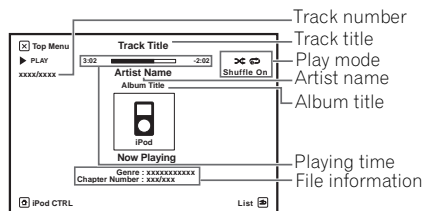

Note

- This system is compatible with the audio and the video of the iPod nano, iPod fifth generation, iPod classic, iPod touch and iPhone (iPod shuffle is not supported). However, that some of the functions may be restricted for some models. Note, however, compatibility may vary depending on the software version of your iPod and iPhone. Please be sure to use the latest available software version.
 - iPod and iPhone are licensed for reproduction of non-copyrighted materials or materials the user is legally permitted to reproduce.
 - Features such as the equalizer cannot be controlled using this receiver, and we recommend switching the equalizer off before connecting.
 - Pioneer cannot under any circumstances accept responsibility for any direct or indirect loss arising from any inconvenience or loss of recorded material resulting from the iPod failure
- The controls of your iPod will be inoperable when connected to this receiver.
 - *VSX-919AH model only:* iPod/USB function cannot be selected for the MULTI-ZONE feature (page 69).
- Note that characters that cannot be displayed on this receiver are displayed as #.
 - This feature is not available for photos or video clips on your iPod. To display video clips, switch iPod operation to the iPod (see *Switching the iPod controls* on page 44).
- If you're in the song category, you can also press **ENTER** to start playback.

- *Sub Zone (VSX-1019AH model only):*

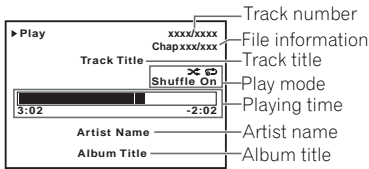

Navigation through categories on your iPod looks like this:

Playlists → Songs
 Artists → Albums → Songs
 Albums → Songs
 Songs
 Podcasts
 Genres → Artists → Albums → Songs
 Composers → Albums → Songs
 Audiobooks
 Shuffle Songs



Tip

- You can play all of the songs in a particular category by selecting the **All** item at the top of each category list. For example, you can play all the songs by a particular artist.

Basic playback controls

The following table shows the basic playback controls for your iPod. Press **iPod USB** to switch the remote control to the iPod/USB operation mode.

Button	What it does
▶	Press to start playback. If you start playback when something other than a song is selected, all the songs that fall into that category will play.
	Pauses/unpauses playback.
◀◀/▶▶	Press and hold during playback to start scanning.
◀◀/▶▶	Press to skip to previous/next track.

Note

- 1 You cannot use this function, when an iPod of fifth generation or iPod nano of first generation is connected.
- 2 When this function is set, iPod images cannot be played on this receiver. However, when video clips recorded on the iPod are played, the playback picture is displayed.

Button	What it does
	Press repeatedly to switch between Repeat One , Repeat All and Repeat Off .
	Press repeatedly to switch between Shuffle Songs , Shuffle Albums and Shuffle Off .
DISP	Press repeatedly to change the song playback information displayed in the front panel display.
ENTER	When browsing, press to move to next levels. During playback, press to set the play and pause modes.
RETURN	When browsing, press to move to previous levels.
◀/▶	When browsing, press to move to previous/next levels.
↑/↓	During Audiobook playback, press to switch the playback speed: Faster ↔ Normal ↔ Slower
TOP MENU	Press to return to the iPod top menu screen.

Switching the iPod controls¹

You can switch over the iPod controls between the iPod and the receiver.

1 Press iPod CTRL to switch the iPod controls.²

This enables operation and display on your iPod, and this receiver's remote control and GUI screen become inactive.

2 Press iPod CTRL again to switch back to the receiver controls.

Playing a USB device

It is possible to playback files¹ using the USB interface on the front of this receiver.

1 Switch on the receiver and your TV.

See *Connecting a USB device* on page 35.²

2 Press iPod USB on the remote control to switch the receiver to the iPod/USB.

Loading appears in the GUI screen as this receiver starts recognizing the USB device connected.³ When the display shows **USB Top** menu you're ready to playback from the USB device.

- *Main Zone:*

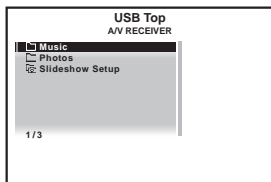

- *Sub Zone (VSX-1019AH model only):*

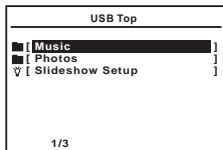

Note

- Compatible USB devices include external magnetic hard drives, portable flash memory (particularly keydrives) and digital audio players (MP3 players) of format FAT16/32. It is not possible to connect this unit to a personal computer for USB playback.
 - Pioneer cannot guarantee compatibility (operation and/or bus power) with all USB mass storage devices and assumes no responsibility for any loss of data that may occur when connected to this receiver.
- Make sure the receiver is in standby when disconnecting the USB device.
- If the file selected cannot be played back, this receiver automatically skips to the next file playable.
 - When the file currently being played back has no title assigned to it, the file name is displayed in the GUI screen instead; when neither the album name nor the artist name is present, the row is displayed as a blank space.
 - Note that non-roman characters in the playlist are displayed as #.
 - *VSX-919AH model only:* iPod/USB function cannot be selected for the MULTI-ZONE feature (page 69).
 - If this error occurs, playback is interrupted and the next playable file is played automatically.
 - This error may occur if the title information is changed on a computer, etc.
- Playback stops when the last song in a USB memory device is played back to the end.
 - When a USB memory device with a large capacity is connected, it may take some time to read all the contents.
 - This receiver does not support a USB hub.
 - Copyrighted audio files cannot be played back on this receiver.
 - DRM-protected audio files cannot be played back on this receiver.

Important

If an **Over Current** message lights in the display, the power requirements of the USB device are too high for this receiver. Try following the points below:

- Switch the receiver off, then on again.
- Reconnect the USB device with the receiver switched off.
- Use a dedicated AC adapter (supplied with the device) for USB power.

If this doesn't remedy the problem, it is likely your USB device is incompatible.

Playing back audio files stored on a USB memory device

The maximum number of levels that you can select in Step 2 (below) is 8. Also, you can display and play back up to 30 000 folders and files within a USB memory device.⁴

- 1 Use **↑/↓** to select 'Music' from the USB Top menu.

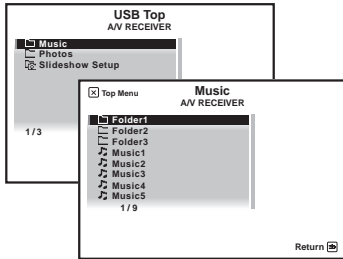

- 2 Use **↑/↓** to select a folder, then press **ENTER** to browse that folder.

- To return to the previous level any time, press **RETURN**.

- 3 Continue browsing until you arrive at what you want to play, then press **▶** to start playback.

- Main Zone:

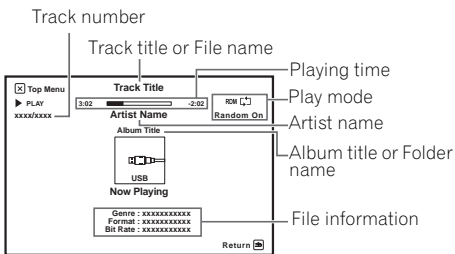

- Sub Zone (VSX-1019AH model only):

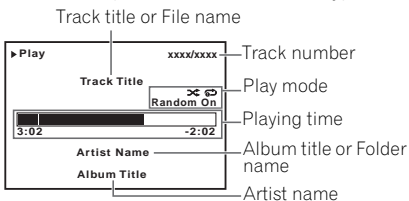

Basic playback controls

The following table shows the basic playback controls for your USB memory device. Press **iPod USB** to switch the remote control to the iPod/USB operation mode.

Button	What it does
▶	Press to start playback.
 	Pauses/unpauses playback.
◀◀/▶▶	Press and hold during playback to start scanning.
◀◀/▶▶	Press to skip to previous/next track.
↺	Press repeatedly to switch between Repeat One , Repeat Folder , Repeat All and Repeat Off .
✂	Press repeatedly to switch between Random On and Random Off .
DISP	Press repeatedly to change the song playback information displayed in the front panel display.
ENTER	When browsing, press to move to next levels. During playback, press to set the play and pause modes.
RETURN	When browsing, press to move to previous levels.
◀/▶	When browsing, press to move to previous/next levels.
TOP MENU	Press to return to the USB Top menu.

Playing back photo files stored on a USB memory device¹

1 Use **↑/↓** to select 'Photos' from the USB Top menu.

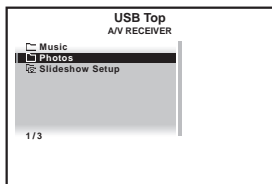

2 Use **↑/↓** to select a folder, then press **ENTER** to browse that folder.

- To return to the previous level any time, press **RETURN**.

3 Continue browsing until you arrive at what you want to play, then press **▶** to start playback.²

The selected content is displayed in full screen and starts a slideshow.

After a slideshow launches, pressing **ENTER** toggles between play and pause.

Basic playback controls

Button(s)	Function
ENTER, ▶	Starts displaying a photo and playing a slideshow.
RETURN, ◀	Stops the Player and returns to the previous menu.
◀◀	Displays the previous photo content
▶▶	Display the next photo content
 	Pauses/unpauses the slideshow

Slideshow Setup

Make the various settings for playing slideshows of photo files here.

1 Use **↑/↓** to select 'Slideshow Setup' from the USB Top menu.

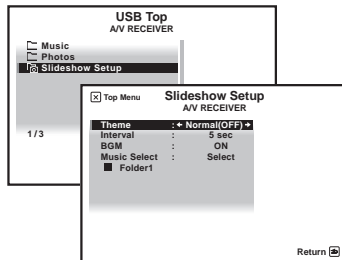

2 Select the setting you want.

- Theme** – Add various effects to the slideshow.
- Interval** – Set the interval for switching the photos. This may not be available depending on the **Theme** setting.
- BGM** – Play music files stored on the USB device while displaying photos.
- Music Select** – Select the folder containing the music files to be played when **BGM** is set to **ON**.

3 When you're finished, press **RETURN**. You will return to the **USB Top** menu.

Note

¹ *VSX-1019AH model only:* Photo files cannot be played in the sub zone.

² If the slideshow is left in the pause mode for five minutes, the list screen reappears.

About playable file formats

The USB function of this receiver supports the following file formats. Note that some file formats are not available for playback although they are listed as playable file formats.

Music files

Category	Extension	Stream		
MP3 ^a	.mp3	MPEG-1, 2, 2.5 Audio Layer-3	Sampling frequency	8 kHz to 48 kHz
			Quantization bitrate	16 bit
			Channel	2 ch
			Bitrate	8 kbps to 320 kbps
			VBR/CBR	Supported/Supported
WAV	.wav	LPCM	Sampling frequency	32 kHz, 44.1 kHz, 48 kHz
			Quantization bitrate	8 bit, 16 bit, 20 bit, 24 bit
			Channel	2 ch, Monaural
WMA	.wma	WMA8/9 ^b	Sampling frequency	8 kHz to 48 kHz
			Quantization bitrate	16 bit
			Channel	2 ch
			Bitrate	8 kbps to 320 kbps
			VBR/CBR	Supported/Supported

a. "MPEG Layer-3 audio decoding technology licensed from Fraunhofer IIS and Thomson multimedia."

b. Files encoded using Windows Media Codec 9 may be playable but some parts of the specification are not supported; specifically, Pro, Lossless, Voice.

Photo files

Category	Extension		
JPEG	.jpg	Format	Meeting the following conditions:
	.jpeg		
	.jpe		
	.jif		
	.jfif		
	Resolution	30 to 8192 pixels vertical, 40 to 8192 pixels horizontal	

Using SIRIUS Radio

With SIRIUS you get The Best Radio on Radio™ with all your favorite entertainment including 100 % commercial-free music, plus superior sports coverage, uncensored talk and comedy, world-class entertainment, news, weather and more for your car, home or office. For more information visit sirius.com or siriuscanada.ca

SIRIUS is available in the US for subscribers with addresses in the continental US and is available in Canada for subscribers with a Canadian address. Required subscription plus compatible SIRIUS tuner and antenna are required and sold separately. SIRIUS Programming is subject to change. Visit <http://www.sirius.com> for the most complete and up-to-date channel lineup and product information.

- **Press SIRIUS to switch to the SIRIUS input.**¹

For best reception, you may need to move the SiriusConnect™ tuner antenna near a window (refer to the manual for the SiriusConnect™ Home tuner for antenna placement recommendations).

- If after pressing **SIRIUS** the display shows **Antenna Error**, try disconnecting the antenna and reconnecting.² If the display shows **Check Sirius Tuner**, check the connection of the AC adapter and this receiver to the SiriusConnect™ tuner.

Listening to SIRIUS Radio

After connecting, you will be able to use this receiver to select channels and navigate categories using the GUI screen.³ The information displayed is as follows:

- *Main Zone:*

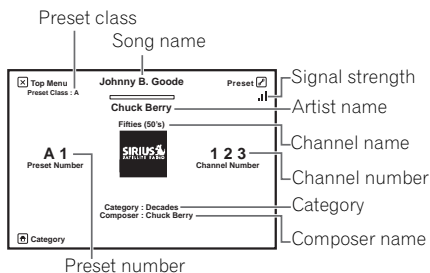

- *Sub Zone (VSX-1019AH model only):*

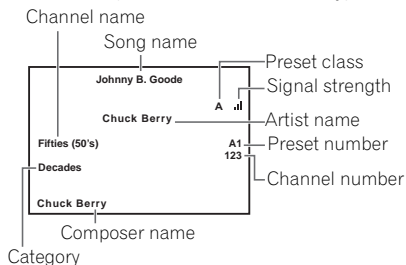

Note

¹ • In order to activate your radio subscription, you will need the SIRIUS ID (SID) which uniquely identifies your tuner. The SID may be found on a sticker located on the packaging, or on the bottom of the tuner itself. The label will have a printed 12-digit SID number. When you have located the SID, write it down in the space provided near the end of this manual. Contact SIRIUS on the internet at: <https://activate.siriusradio.com>

- Follow the prompts to activate your subscription, or you can also call SIRIUS toll-free at 1-888-539-SIRIUS (1-888-539-7474).
- Select **0 (SIRIUS ID)** from the GUI screen to check the Radio ID of the SIRIUS Connect tuner (see *Selecting channels and browsing by genre* below).

² You can check the strength of reception in *Using the SIRIUS Menu* on page 51.

³ It's easiest if you have your TV switched on to take advantage of the GUI screens. You can, however, use just the front panel display to do everything if you prefer.

Selecting channels and browsing by genre

From the SIRIUS Channel Guide, you can browse SIRIUS Radio channels in the order that they appear, or you can narrow your channel search by genre.

- *Main Zone:*

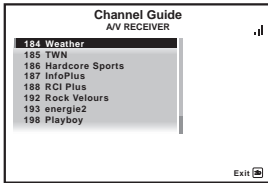

- *Sub Zone (VSX-1019AH model only):*

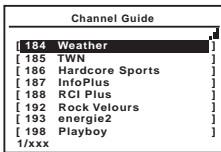

1 Press **↑/↓** to enter the SIRIUS Channel Guide, then navigate through the channels one at a time with **↑/↓**, then press **ENTER** to listen to the SIRIUS radio broadcast.

- To browse by genre, first press **CATEGORY**, use **↑/↓** to select a genre, then press **ENTER**.
- To cancel and exit any time, press **RETURN**.

Tip

- You can select channels directly by pressing **D.ACCESS**, then the three-digit channel number.
- You can press **DISP** to change SIRIUS Radio information in the front panel display.
- The currently selected channel is automatically chosen (without pressing **ENTER**) after 10 seconds.

Note

¹ You can reset the Channel presets, Memory, Channel Skip/Add, Parental Lock and Password settings in *Resetting the system* on page 72.

Saving channel presets

This receiver can memorize up to 63 channels, stored in seven banks, or classes (A to G) of 9 channels each.

1 Select the channel you want to memorize.

See *Selecting channels and browsing by genre* above.

2 Press **T.EDIT**.

The display shows a blinking memory class.

3 Press **CLASS** to select one of the seven classes, then press **←/→** to select the channel preset you want.

You can also use the number buttons to select a preset.

4 Press **ENTER**.

After pressing **ENTER**, the preset class and number stop blinking and the receiver stores the SIRIUS channel.

Tip

- You can also press **MEMORY** during reception display to save the information of up to five songs. See *Using the SIRIUS Menu* below to recall this information.¹

Listening to channel presets

1 Press **CLASS** to select the class in which the channel is stored.

Press repeatedly to cycle through classes A to G.

2 Press **←/→** to select the channel preset you want.

- You can also use the number buttons on the remote control to recall the channel preset.

Using the SIRIUS Menu

The SIRIUS Menu provides additional SIRIUS Radio features.

1 Press TOP MENU.

2 Use ↑/↓ to select a menu item, then press ENTER.

Choose from the following menu items:

- **Channel Skip/Add** – Use ↑/↓ and **ENTER** to select channels you would like to remove/restore from/to the channel guide.
- **Parental Lock** – Use ↑/↓ and **ENTER** to select channels you would like to place under parental lock. Channels put under parental lock are not displayed in the Channel Guide, but may be accessed by directly inputting their channel number and providing the parental lock password.
- **Antenna Aiming** – Check the strength of satellite and terrestrial reception.
- **Memory Recall** – Use ↑/↓ to browse your saved song information (see *Tip* above).
- **Password Set** – Set the parental lock password.

3 When you're finished press TOP MENU to return to the reception display.

Listening to the radio

The following steps show you how to tune in to FM and AM radio broadcasts using the automatic (search) and manual (step) tuning functions. If you already know the frequency of the station you want, see *Tuning directly to a station* below. Once you are tuned to a station you can memorize the frequency for recall later—see *Saving station presets* on page 52 for more on how to do this.

1 Press TUNER to select the tuner.

2 Use BAND to change the band (FM or AM), if necessary.

Each press switches the band between FM and AM.

3 Tune to a station.

There are three ways to do this:

Automatic tuning – To search for stations in the currently selected band, press and hold **TUNE** ↑/↓ for about a second. The receiver will start searching for the next station, stopping when it has found one. Repeat to search for other stations.

Manual tuning – To change the frequency one step at a time, press **TUNE** ↑/↓.

High speed tuning – Press and hold **TUNE** ↑/↓ for high speed tuning. Release the button at the frequency you want.

Improving FM sound

If the **TUNED** or **STEREO** indicator doesn't light when tuning to an FM station because the signal is weak, press **MPX** to switch the receiver into mono reception mode. This should improve the sound quality and allow you to enjoy the broadcast.

Using Neural THX

This feature uses Neural Surround™, THX® technologies to achieve optimal surround sound from FM radio.

- While listening to FM radio, press **AUTO/ALC/DIRECT** for Neural THX listening.

See *About Neural – THX Surround* on page 114 for more on this.

The **Neural THX** mode can be selected also with **STANDARD**.

Tuning directly to a station

Sometimes, you'll already know the frequency of the station you want to listen to. In this case, you can simply enter the frequency directly using the number buttons on the remote control.

1 Press TUNER to select the tuner.

2 Use BAND to change the band (FM or AM), if necessary.

Each press switches the band between FM and AM.

3 Press **D.ACCESS** (Direct Access).

4 Use the number buttons to enter the frequency of the radio station.

For example, to tune to **106.00** (FM), press **1, 0, 6, 0, 0**.

If you make a mistake halfway through, press **D.ACCESS** twice to cancel the frequency and start over.

Saving station presets

If you often listen to a particular radio station, it's convenient to have the receiver store the frequency for easy recall whenever you want to listen to that station. This saves the effort of manually tuning in each time. This receiver can memorize up to 63 stations, stored in seven banks, or classes (A to G) of 9 stations each. When saving an FM frequency, the **MPX** setting (see page 51) is also stored.

1 Tune to a station you want to memorize.

See *Listening to the radio* on page 51 for more on this.

2 Press **T.EDIT** (TUNER EDIT).

The display shows **PRESET MEMORY**, then a blinking memory class.

3 Press **CLASS** to select one of the seven classes, then press **PRESET** **←/→** to select the station preset you want.

You can also use the number buttons to select a station preset.

4 Press **ENTER**.

After pressing **ENTER**, the preset class and number stop blinking and the receiver stores the station.

Naming station presets

For easier identification, you can name your station presets.

1 Choose the station preset you want to name.

See *Listening to station presets* below for how to do this.

2 Press **T.EDIT** (TUNER EDIT).

The display shows **PRESET NAME**, then a blinking cursor at the first character position.

3 Input the name you want.

Choose from the following characters for a name up to eight characters long.

ABCDEFGHIJKLMNOPQRSTUVWXYZ

abcdefghijklmnopqrstuvwxyz

0123456789

! " # \$ % & ' () * + , - . / : ; < = > ? @ [\] ^ _ { } ~ [space]

Use **↑/↓** to select a character, **←/→** to set the position, and **ENTER** to confirm your selection.



Tip

- To erase a station name, simply repeat steps 1 to 3 and input eight spaces instead of a name.
- Once you have named a station preset, you can press **DISP** when listening to a station to switch the display between name and frequency.

Listening to station presets

You will need to have some presets stored to do this. See *Saving station presets* above if you haven't done this already.

1 Press **TUNER** to select the tuner.

2 Press **CLASS** to select the class in which the station is stored.

Press repeatedly to cycle through classes A to G.

3 Press **PRESET** **←/→** to select the station preset you want.

- You can also use the number buttons on the remote control to recall the station preset.

Chapter 6:

Listening to your system

**Important**

- The listening modes and many features described in this section may not be available depending on the current source, settings and status of the receiver.

**Tip**

- When an **ALC** is selected, the effect level can be adjusted using the **EFFECT** parameter in *Setting the Audio options* on page 64.

Auto playback

There are many ways to listen back to sources using this receiver, but for the simplest, most direct listening option is the Auto Surround feature. The receiver automatically detects what kind of source you're playing and selects multichannel or stereo playback as necessary.¹

- **While listening to a source, press **RECEIVER**, then press **AUTO/ALC/DIRECT (AUTO SURR/ALC/STREAM DIRECT)**² for auto playback of a source.**

AUTO SURROUND shows briefly in the display before showing the decoding or playback format. Check the digital format indicators in the front panel display to see how the source is being processed.

- When listening to the FM radio, the Neural THX feature is selected automatically (see *Using Neural THX* on page 51 for more on this).

In the Auto level control (ALC) mode, this receiver equalizes playback sound levels.

Listening in surround sound

Using this receiver, you can listen to any source in surround sound. However, the options available will depend on your speaker setup and the type of source you're listening to. If you connected surround back speakers, see also *Using surround back channel processing* on page 56.

Standard surround sound

The following modes provide basic surround sound for stereo and multichannel sources.³

- **While listening to a source, press **RECEIVER**, then press **STANDARD (STANDARD SURROUND)**.**

If necessary, press repeatedly to select a listening mode.

- If the source is Dolby Digital, DTS, or Dolby Surround encoded, the proper decoding format will automatically be selected and shows in the display.⁴

Note

¹ • Stereo surround (matrix) formats are decoded accordingly using **Neo:6 CINEMA** or **Pro Logic IIx MOVIE** (see *Listening in surround sound* above for more on these decoding formats).

• The Auto Surround feature is canceled if you connect headphones.

² For more options using this button, see *Using Stream Direct* on page 56.

³ In modes that give 6.1 channel sound, the same signal is heard from both surround back speakers.

⁴ If surround back channel processing (page 56) is switched **OFF**, or the surround back speakers are set to **NO** (this happens automatically if the *Surround back speaker setting* on page 94 is set to anything but **Normal**), **Pro Logic IIx** becomes **Pro Logic II** (5.1 channel sound).

With two channel sources, you can select from:

- **Dolby Pro Logic IIx MOVIE** – Up to 7.1 channel sound, especially suited to movie sources
- **Dolby Pro Logic IIx MUSIC** – Up to 7.1 channel sound, especially suited to music sources¹
- **Dolby Pro Logic IIx GAME** – Up to 7.1 channel sound, especially suited to video games
- **Dolby PRO LOGIC** – 4.1 channel surround sound (sound from the surround speakers is mono)
- **Neo:6 CINEMA** – 7.1 channel sound, especially suited to movie sources
- **Neo:6 MUSIC** – 7.1 channel sound, especially suited to music sources²
- **Neural THX** – Up to 7.1 channel sound, especially suited to music sources³

With multichannel sources, if you have connected surround back speaker(s) and have selected **SBCh ON**, you can select (according to format):

- **Dolby Pro Logic IIx MOVIE** – See above (only available when you're using two surround back speakers)
- **Dolby Pro Logic IIx MUSIC** – See above
- **Dolby Digital EX** – Creates surround back channel sound for 5.1 channel sources and provides pure decoding for 6.1 channel sources (like Dolby Digital Surround EX)
- **DTS-ES** – Allows you to hear 6.1 channel playback with DTS-ES encoded sources
- **DTS Neo:6** – Allows you to hear 6.1 channel playback with DTS encoded sources

Using the Advanced surround effects

The Advanced surround effects can be used for a variety of additional surround sound effects. Most Advanced Surround modes are designed to be used with film soundtracks, but some modes are also suited for music sources. Try different settings with various soundtracks to see which you like.

- Press **RECEIVER**, then press **ADV SURR (ADVANCED SURROUND)** repeatedly to select a listening mode.⁴
 - **ACTION** – Designed for action movies with dynamic soundtracks
 - **DRAMA** – Designed for movies with lots of dialog
 - **SCI-FI** – Designed for science fiction with lots of special effects
 - **MONO FILM** – Creates surround sound from mono soundtracks
 - **ENT.SHOW** – Suitable for musical sources
 - **EXPANDED** – Creates an extra wide stereo field⁵
 - **TV SURROUND** – Provides surround sound for both mono and stereo TV sources
 - **ADVANCED GAME** – Suitable for video games
 - **SPORTS** – Suitable for sports programs
 - **CLASSICAL** – Gives a large concert hall-type sound
 - **ROCK/POP** – Creates a live concert sound for rock and/or pop music

Note

- 1 When listening to 2-channel sources in Dolby Pro Logic IIx Music mode, there are three further parameters you can adjust: **C.WIDTH**, **DIMENSION** and **PANORAMA**. See *Setting the Audio options* on page 64 to adjust them.
- 2 When listening to 2-channel sources in Neo:6 Cinema or Neo:6 Music mode, you can also adjust the center image effect (see *Setting the Audio options* on page 64).
- 3 **Neural THX** can be selected for 2-channel signals for which the input signal is PCM (48 kHz or less), Dolby Digital, DTS or analog 2-channel sources.
- 4 • Depending on the source and the sound mode you have selected, you may not get sound from the surround back speakers in your setup. For more on this, refer to *Using surround back channel processing* on page 56.
 - If you press **ADV SURR** when the headphones are connected, the **PHONES SURROUND** mode will automatically be selected.
- 5 Use with Dolby Pro Logic for a stereo surround effect (stereo field is wider than Standard modes with Dolby Digital sources).

- **UNPLUGGED** – Suitable for acoustic music sources
- **EXT.STEREO** – Gives multichannel sound to a stereo source, using all of your speakers
- **PHONES SURR.** – When listening through headphones, you can still get the effect of overall surround.

Tip

- When an Advanced Surround listening mode is selected, the effect level can be adjusted using the **EFFECT** parameter in *Setting the Audio options* on page 64.

Listening in stereo

When you select **STEREO**, you will hear the source through just the front left and right speakers (and possibly your subwoofer depending on your speaker settings). Dolby Digital, DTS and WMA9 Pro multichannel sources are downmixed to stereo.

- **While listening to a source, press **RECEIVER**, then press **STEREO** for stereo playback.**

Press repeatedly to switch between:

- **STEREO** – The audio is heard with your surround settings and you can still use the Midnight, Loudness, and Tone functions.
- **F.S.SURR FOCUS** – See *Using Front Stage Surround Advance* below for more on this.
- **F.S.SURR WIDE** – See *Using Front Stage Surround Advance* below for more on this.

Using Front Stage Surround Advance

The Front Stage Surround Advance function allows you to create natural surround sound effects using just the front speakers and the subwoofer.

- **While listening to a source, press **RECEIVER**, then press **STEREO** to select Front Stage Surround Advance modes.**
 - **STEREO** – See *Listening in stereo* above for more on this.
 - **F.S.SURR FOCUS** – Use to provide a rich surround sound effect directed to the center of where the front left and right speakers sound projection area converges.
 - **F.S.SURR WIDE** – Use to provide a surround sound effect to a wider area than **FOCUS** mode.¹

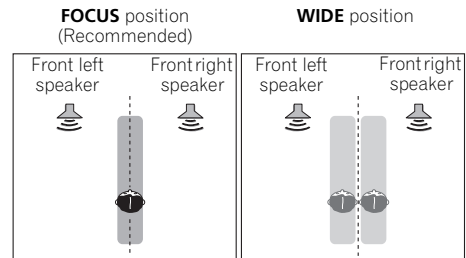

Note

¹ When using **F.S.SURR WIDE**, a better effect can be obtained if the **Full Auto MCACC** procedure under **Advanced MCACC** is performed. For more on this, refer to *Automatically setting up for surround sound (Auto MCACC)* on page 37.

Using Stream Direct

Use the Stream Direct modes when you want to hear the truest possible reproduction of a source. All unnecessary signal processing is bypassed, and you're left with the pure analog or digital sound source.

- **While listening to a source, press **RECEIVER**, then press **AUTO/ALC/DIRECT (AUTO SURR/ALC/STREAM DIRECT)** to select the mode you want.**

Check the digital format indicators in the front panel display to see how the source is being processed.

- **AUTO SURROUND** – See *Auto playback* on page 53.
- **ALC** – Listening in Auto level control mode (page 53).
- **DIRECT** – Sources are heard according to the settings made in the Surround Setup (speaker setting, channel level, speaker distance, acoustic calibration EQ, and X-curve), as well as with dual mono, the input attenuator, and any sound delay settings. You will hear sources according to the number of channels in the signal.
- **PURE DIRECT** – Analog sources are heard without any digital processing. No sound is output from the Speaker B in this mode.

Using surround back channel processing

- Default setting: **SBch ON**

You can have the receiver automatically use 6.1 or 7.1 decoding for 6.1 encoded sources (for example, Dolby Digital EX or DTS-ES), or you can choose to always use 6.1 or 7.1 decoding (for example, with 5.1 encoded material). With 5.1 encoded sources, a surround back channel will be generated, but the material may sound better in the 5.1 format for which it was originally encoded (in which case, you can simply switch surround back channel processing off).

- With a 7.1-channel surround system, audio signals that have undergone matrix decoding processing through surround back channel processing to which the Up Mix function is added are output from the surround back speakers.
- **Press **RECEIVER**, then press **SBch** repeatedly to cycle the surround back channel options.**

Each press cycles through the options as follows:

- **SBch ON** – Matrix decoding processing for generating the surround back component from the surround component is turned on.
- **SBch AUTO** – Matrix decoding processing for generating the surround back component from the surround component is switched automatically. Matrix decoding processing is only performed when surround back channel signals are detected in the input signals.
- **SBch OFF** – Matrix decoding processing for generating the surround back component from the surround component is turned off.

Using the Virtual Surround Back mode

- Default setting: **ON**

When you're not using surround back speakers, selecting this mode allows you to hear a virtual surround back channel through your surround speakers. You can choose to listen to sources with no surround back channel information, or if the material sounds better in the format (for example, 5.1) for which it was originally encoded, you can have the receiver only apply this effect to 6.1 encoded sources like Dolby Digital EX or DTS-ES.¹

• Press **SBCh** repeatedly to cycle the virtual surround back channel options.

Each press cycles through the options as follows:

- **VirtualSB ON** – Virtual Surround Back is always used (for example, on 5.1 encoded material)
- **VirtualSB AUTO** – Virtual Surround Back is automatically applied to 6.1 encoded sources (for example, Dolby Digital EX or DTS-ES)
- **VirtualSB OFF** – Virtual Surround Back mode is switched off

Setting the Up Mix function

In a 7.1-channel surround system with surround speakers placed directly at the sides of the listening position, the surround sound of 5.1-channel sources is heard from the side. The Up Mix function mixes the sound of the surround speakers with the surround back speakers so that the surround sound is heard from diagonally to the rear as it should be.²

- Using the Up Mix function is effective when the speakers in the 7.1-channel surround system are set up as recommended in the example on page 17.
- Depending on the positions of the speakers and the sound source, in some cases it may not be possible to achieve good results. In this case, set the setting to **OFF**.

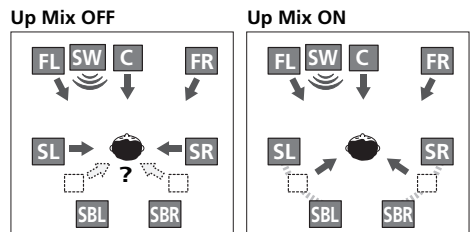

1 Switch the receiver into standby.

2 While holding down **ENTER** on the front panel, press **STANDBY/ON**.

The display shows **RESET ◀ NO ▶**.

Use **TUNE +/-** (or **↑/↓** on the remote control) to select **UP MIX ◀ON ▶**, and then use **PRESET +/-** (or **←/→** on the remote control) to select **ON** or **OFF**.

3 Press **ENTER** to confirm.

- When set to **ON**, the **UP MIX** indicator on the front panel lights.

Note

- You can't use the Virtual Surround Back mode when the headphones are connected to this receiver or when any of the stereo, Front Stage Surround Advance or Stream Direct mode is selected.
 - You can only use the Virtual Surround Back mode if the surround speakers are on and the **SB** setting is set to **NO** or if **Front Bi-Amp. Speaker B** or **Zone 2** is selected at **Surr Back System**.
 - The Virtual Surround Back mode cannot be applied to sources that do not have surround channel information.
- Set to **ON** regardless of this setting when playing DTS-HD signals.
 - May automatically be set to **OFF** even when set to **ON**, depending on the input signal and listening mode.

Selecting MCACC presets

- Default setting: **MEMORY 1**

If you have calibrated your system for different listening positions¹, you can switch between settings to suit the kind of source you're listening to and where you're sitting (for example, watching movies from a sofa, or playing a video game close to the TV).

- **While listening to a source, press RECEIVER, then press MCACC.**

Press repeatedly to select one of the six MCACC presets².

See *Data Management* on page 91 to check and manage your current settings.

Choosing the input signal

On this receiver, it is possible to switch the input signals for the different inputs as described below.³

- **Press RECEIVER, then press SIGNAL SEL to select the input signal corresponding to the source component.**

Each press cycles through the options as follows:

- **AUTO** – The receiver selects the first available signal in the following order: **HDMI; DIGITAL; ANALOG.**
- **ANALOG** – Selects an analog signal.
- **DIGITAL** – Selects an optical or coaxial digital signal.
- **HDMI** – Selects an HDMI signal.⁴
- **PCM** – For PCM input signals.⁵ The receiver selects the first available signal in the following order: **HDMI; DIGITAL.**

When set to **DIGITAL** or **AUTO**, the indicators light according to the signal being decoded, as follows:

- **DI DIGITAL** lights with Dolby Digital decoding.
- **DI DIGITAL PLUS** lights with Dolby Digital Plus decoding.
- **DI TrueHD** lights with Dolby TrueHD decoding.
- **DTS** lights with DTS decoding.
- **DTS HD** lights with DTS-HD decoding.
- **MSTR** lights with DTS-HD Master Audio decoding.
- **96/24** lights with DTS 96/24 decoding.

Note

- 1 Different presets might also have separate calibration settings for the same listening position, depending on how you're using your system. These presets can be set in *Automatically setting up for surround sound (Auto MCACC)* on page 37 or *Automatic MCACC (Expert)* on page 78, either of which you should have already completed.
- 2 • These settings have no effect when headphones are connected.
 - You can also press **◀/▶** to select the MCACC preset.
- 3 • This receiver can only play back Dolby Digital, PCM (32 kHz to 192 kHz), DTS (including DTS 96/24) and WMA9 Pro digital signal formats. The compatible signals via the HDMI terminals are: Dolby Digital, DTS, WMA9 Pro, PCM (32 kHz to 192 kHz), Dolby TrueHD, Dolby Digital Plus, DTS-EXPRESS, DTS-HD Master Audio, SACD and DVD Audio (including 192 kHz). With other digital signal formats, set to **ANALOG** (the **MULTI CH IN** and **TUNER**).
 - You may get digital noise when a LD or CD player compatible with DTS is playing an analog signal. To prevent noise, make the proper digital connections (page 29) and set the signal input to **DIGITAL**.
 - Some DVD players don't output DTS signals. For more details, refer to the instruction manual supplied with your DVD player.
- 4 When the **HDMI** option in *Setting the Audio options* on page 64 is set to **THROUGH**, the sound will be heard through your TV, not from this receiver.
- 5 • This is useful if you find there is a slight delay before **AUTO** recognizes the PCM signal on a CD, for instance.
 - When **PCM** is selected, noise may be output during playback of non-PCM sources. Please select another input signal if this is a problem.

– **WMA9 Pro** lights to indicate that a WMA9 Pro signal is being decoded.

- **HDMI** is not assigned by default. To select an HDMI signal, conduct the input setup procedure (see *The Input Setup menu* on page 39).

Better sound using Phase Control

This receiver's Phase Control feature uses phase correction measures to make sure your sound source arrives at the listening position in phase, preventing unwanted distortion and/or coloring of the sound.

Phase Control technology provides coherent sound reproduction through the use of phase matching¹ for an optimal sound image. The default setting is on and we recommend leaving Phase Control switched on for all sound sources.

- Press **RECEIVER**, then press **PHASE CTRL (PHASE CONTROL)** to switch on phase correction.

The **PHASE CONTROL** indicator on the front panel lights.

Note

- 1 • Phase matching is a very important factor in achieving proper sound reproduction. If two waveforms are 'in phase', they crest and trough together, resulting in increased amplitude, clarity and presence of the sound signal. If a crest of a wave meets a trough, then the sound will be 'out of phase' and an unreliable sound image will be produced.
 - The **PHASE CONTROL** feature is available even when the headphones are plugged in.
 - If your subwoofer has a phase control switch, set it to the plus (+) sign (or 0°). However, the effect you can actually feel when **PHASE CONTROL** is set to **ON** on this receiver depends on the type of your subwoofer. Set your subwoofer to maximize the effect. It is also recommended you try changing the orientation or the place of your subwoofer.
 - Set the built-in lowpass filter switch of your subwoofer to off. If this cannot be done on your subwoofer, set the cutoff frequency to a higher value.
 - If the speaker distance is not properly set, you may not have a maximized **PHASE CONTROL** effect.
 - The **PHASE CONTROL** mode cannot be set to **ON** in the following cases:
 - When the **PURE DIRECT** mode is switched on.
 - When the **MULTI CH IN** input is selected.
 - When the HDMI audio output parameter is set to **THROUGH** in *Setting the Audio options* on page 64.

Chapter 7

KURO LINK

Synchronized operation with a KURO LINK-compatible Pioneer flat panel TV or Blu-ray disc player or with a component of another make that supports the KURO LINK function is possible when the component is connected to the receiver using an HDMI cable.

For details about concrete operations, settings, etc., refer to also the operating instructions for each component.

- You cannot use this function with components that do not support KURO LINK.
- We do not guarantee this receiver will work with Pioneer KURO LINK-compatible components or components of other makes that support the KURO LINK function. We do not guarantee that all synchronized operations will work with components of other makes that support the KURO LINK function.
- Use a High Speed HDMI™ cable when you want to use the KURO LINK function. The KURO LINK function may not work properly if a different type of HDMI cable is used.

Making the KURO LINK connections

You can use synchronized operation for a connected flat panel TV and up to four (*VSX-1019AH model*)/three (*VSX-919AH model*) other components.

Be sure to connect the flat panel TV's audio cable to the audio input of this unit.

For details, see *Connecting your TV and playback components* on page 23.



Important

- When connecting this system or changing connections, be sure to switch the power off and disconnect the power cord from the wall socket.
After completing all connections, connect the power cords to the wall socket.
- After this receiver is connected to an AC outlet, a 2 second to 10 second HDMI initialization process begins. You cannot carry out any operations during initialization. The HDMI indicator on the display unit blinks during initialization, and you can turn this receiver on once it has stopped blinking.
- To get the most out of this function, we recommend that you connect your HDMI component not to a flat panel TV but rather directly to the HDMI terminal on this receiver.
- While the receiver is equipped with four (*VSX-1019AH model*)/three (*VSX-919AH model*) HDMI inputs, the KURO LINK function can only be used with up to three DVD or Blu-ray disc players or up to three DVD or Blu-ray disc recorders.

Cautions on the KURO LINK function

- Connect the TV directly to this receiver.
Interrupting a direct connection with other amps or an AV converter (such as an HDMI switch) can cause operational errors.
- Only connect components (Blu-ray disc player, etc.) you intend to use as a source to the HDMI input of this receiver.
Interrupting a direct connection with other amps or an AV converter (such as an HDMI switch) can cause operational errors.
- When **KURO LINK** is set to **ON**, HDMI Input is automatically set to **OFF**.
- If a listening mode other than **AUTO SURROUND, ALC, DIRECT, PURE DIRECT** or **STEREO** is selected while the PQLS effect is enabled, the PQLS effect is disabled.
- When this receiver is connected by HDMI cable to a Pioneer player that is compatible with the PQLS function via HDMI connection and a CD is played or HDMI reauthentication is performed (the **HDMI** indicator blinks), the PQLS effect is enabled and the listening mode is set to **AUTO SURROUND** if a listening mode other than **AUTO SURROUND, ALC, DIRECT, PURE DIRECT** or **STEREO** is selected.
- When the receiver's **KURO LINK** is turned **ON**, even if the receiver's power is in the standby mode, it is possible to output the audio and video signals from a player via HDMI to the TV without producing sound from the receiver, but only when a KURO LINK-compatible component (Blu-ray disc player, etc.) and compatible TV are connected. In this case, the receiver's power turns on and the power and **HDMI** indicators light.

About connections with a product of a different brand that supports the KURO LINK function

The synchronized operations below can be used when the receiver's KURO LINK function is connected to a TV of a brand other than Pioneer that supports the KURO LINK function. (Depending on the TV, however, some of the KURO LINK functions may not work.)

- You can set whether to output the sound over the speakers connected to the receiver or over the TV's speakers using the TV's menu screen.
- You can adjust the receiver's volume or mute the sound using the TV's remote control.
- When the TV's power is set to standby, the receiver's power is also set to standby. (Only when the input for a component connected to the receiver by HDMI connection is selected or when watching the TV)
- The sound of TV programs or an external input connected to the TV can also be output from the speakers connected to the receiver. (This requires connection of an optical digital cable, etc., in addition to the HDMI cable.)

The synchronized operations below can be used when the receiver's KURO LINK function is connected to a player or recorder of a brand other than Pioneer that supports the KURO LINK function.

- When playback starts on the player or recorder, the receiver's input switches to the HDMI input to which that component is connected.

See the Pioneer website for the latest information on the models of non-Pioneer brands and products that support the KURO LINK function.

KURO LINK Setup

You must adjust the settings of this receiver as well as KURO LINK-compatible connected components in order to make use of the KURO LINK function. For more information see the operating instructions for each component.

- 1 Press **RECEIVER**, then press **Home Menu**.
- 2 Select **'System Setup'**, then press **ENTER**.
- 3 Select **'Other Setup'**, then press **ENTER**.

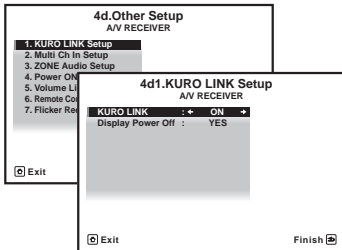

4 Select the 'KURO LINK' setting you want.

Choose whether to set this unit's KURO LINK function **ON** or **OFF**. You will need to set it to **ON** to use the KURO LINK function.

When using a component that does not support the KURO LINK function, set this to **OFF**.

- **ON** – Enables the KURO LINK function. When this unit's power is turned off and you have a supported source begin playback while using the KURO LINK function, the audio and video output from the HDMI connection are output from the flat panel TV.
- **OFF** – The KURO LINK is disabled. Synchronized operations cannot be used. When this unit's power is turned off, audio and video of sources connected via HDMI are not output.

5 Select the 'Display Power Off' setting you want.

If the TV's power is turned off while using the KURO LINK function, the receiver's power is also turned off (all power off function). This function can be disabled.

- **YES** – The all power off function is enabled. The receiver's power turns off together with the TV's power. This function only works when the input for a component connected to the receiver by HDMI connection is selected or when watching the TV.
- **NO** – The all power off function is disabled. The receiver's power is not affected when the TV's power is turned off.

6 When you're finished, press HOME MENU.

You will finish to **HOME MENU**.

Setting the PQLS function

PQLS (Precision Quartz Lock System) is a digital audio signal transfer control technology using the KURO LINK function. It offers higher-quality audio playback by controlling audio signals from the receiver to a PQLS compatible player, etc. This enables removing jitter that has a negative effect on the quality of the sound and is generated upon transmission.

This function is activated when **KURO LINK** is set to **ON**.

1 Press **RECEIVER**, then press **PQLS** to select **PQLS** setting.

The setting is displayed on the front panel display.

- **PQLS AUTO** – PQLS is enabled. A precision quartz controller in this receiver eliminates distortion caused by timing errors (jitter), giving you the best possible digital-to-analog conversion from audio CD sources when you use the HDMI interface. This is valid as an HDMI function for PQLS-compatible players.
- **PQLS OFF** – PQLS is disabled.

Before using synchronization

Once you have finished all connections and settings, you must:

- 1 Put all components into standby mode.**
- 2 Turn the power on for all components, with the power for the flat panel TV being turned on last.**
- 3 Choose the HDMI input to which the TV is connected to this receiver, and see if video output from connected components displays properly on the screen or not.**
- 4 Check whether the components connected to all HDMI inputs are properly displayed.**

Synchronized amp mode

The synchronized amp mode can be set from the KURO LINK-compatible TV's remote control. See the explanation below for operations in the synchronized amp mode.

These functions are set from the TV's menu screen. For more information, refer to the operating instructions of the KURO LINK-compatible TV.

Synchronized amp mode operations

When using the synchronized amp mode, the KURO LINK-compatible component connected to the receiver operates in sync as described below.

- The receiver's volume can be set and the sound can be muted using the TV's remote control.
- When the TV's power is set to standby, the receiver's power is also set to standby. (Only when the input for a component connected to the receiver by HDMI connection is selected or when watching the TV)

- The receiver's input switches automatically when the KURO LINK-compatible component is played.
- The receiver's input switches automatically when the TV's channel is switched.
- The synchronized amp mode remains in effect even if the receiver's input is switched to a component other than one connected by HDMI.

The operations below can also be used on Pioneer KURO LINK-compatible flat panel TVs.

- When the receiver's volume is adjusted or the sound is muted, the volume status is displayed on the flat panel TV's screen.
- When the OSD language is switched on the flat panel TV, the receiver's language setting also switches accordingly.

Canceling synchronized amp mode

- When the synchronized amp mode is canceled, the receiver's power turns off if you were viewing an HDMI input or a TV program on the TV.
- When in the synchronized amp mode, the synchronized amp mode is canceled when the receiver's power is turned off. To turn the synchronized amp mode back on, select the synchronized amp mode using the TV's remote control.
- When in the synchronized amp mode, the synchronized amp mode is canceled if an operation that produces sound from the TV is performed from the TV's menu screen, etc.

Chapter 8:

Using other functions

Setting the Audio options

There are a number of additional sound settings you can make using the **AUDIO PARAMETER** menu. The defaults, if not stated, are listed in bold.



Important

- Note that if a setting doesn't appear in the **AUDIO PARAMETER** menu, it is unavailable due to the current source, settings and status of the receiver.

1 Press **RECEIVER, then press **AUDIO PARAMETER**.**

2 Use **↑/↓ to select the setting you want to adjust.**

Depending on the current status/mode of the receiver, certain options may not be able to be selected. Check the table below for notes on this.

3 Use **←/→ to set it as necessary.**

See the table below for the options available for each setting.

4 Press **RETURN to confirm and exit the menu.**

Setting	What it does	Option(s)
MCACC (MCACC preset)	Selects your favorite MCACC preset memory when multiple preset memories are saved. When a MCACC preset memory has been renamed, the given name is displayed.	M1. MEMORY 1 to M6. MEMORY 6 Default: M1. MEMORY 1
EQ (Acoustic Calibration EQ)	Switches on/off the effects of EQ Pro.	ON <i>OFF^a</i>
S-WAVE (Standing Wave)	Switches on/off the effects of Standing Wave Control.	ON <i>OFF</i>
DELAY (Sound Delay)	Some monitors have a slight delay when showing video, so the soundtrack will be slightly out of sync with the picture. By adding a bit of delay, you can adjust the sound to match the presentation of the video.	0.0 to 10.0 (frames) <i>1 second = 30 frames (NTSC)</i> Default: 0.0
MIDNIGHT	Allows you to hear effective surround sound of movies at low volumes.	MIDNIGHT/ LOUDNESS OFF <i>MIDNIGHT ON</i>
LOUDNESS	Used to get good bass and treble from music sources at low volumes.	 <i>LOUDNESS ON</i>
TONE^b (Tone Control)	Applies the treble and bass tone controls to a source, or bypasses them completely.	BYPASS <i>ON</i>

Setting	What it does	Option(s)
BASS^c	Adjusts the amount of bass.	-6 to +6 (dB) Default: 0 (dB)
TREBLE^c	Adjusts the amount of treble.	-6 to +6 (dB) Default: 0 (dB)
S.RTRV (Sound Retriever)	With the Sound Retriever function, DSP processing is used to compensate for the loss of audio data upon compression, improving the sound's sense of density and modulation.	OFF^d <i>ON</i>
DNR (Digital Noise Reduction)	May improve the quality of sound in a noisy source (for example, video tape with lots of background noise) when switched on.	OFF <i>ON</i>
DIALOG E. (Dialog Enhancement)	Localizes dialog in the center channel to make it stand out from other background sounds in a TV or movie soundtrack.	OFF <i>ON</i>
DUAL (Dual Mono)	Specifies how dual mono encoded Dolby Digital soundtracks should be played. Dual mono is not widely used, but is sometimes necessary when two languages need to be sent to separate channels.	CH1 – Channel 1 is heard only CH2 – Channel 2 is heard only CH1 CH2 – Both channels heard from front speakers
DRC (Dynamic Range Control)	Adjusts the level of dynamic range for movie soundtracks optimized for Dolby Digital, DTS, Dolby Digital Plus, Dolby TrueHD, DTS-HD and DTS-HD Master Audio (you may need to use this feature when listening to surround sound at low volumes).	AUTO^e <i>MAX</i> <i>MID</i> <i>OFF</i>
LFE (LFE Attenuate)	Some Dolby Digital and DTS audio sources include ultra-low bass tones. Set the LFE attenuator as necessary to prevent the ultra-low bass tones from distorting the sound from the speakers. The LFE is not limited when set to 0 dB, which is the recommended value. When set to -5 dB, -10 dB, -15 dB or -20 dB, the LFE is limited by the respective degree. When OFF is selected, no sound is output from the LFE channel.	0dB/ -5dB/ -10dB/ -15dB/ -20dB <i>OFF</i>
SACD GAIN^f	Brings out detail in SACDs by maximizing the dynamic range (during digital processing).	0dB <i>+6 dB</i>
HDMI^g (HDMI Audio)	Specifies the routing of the HDMI audio signal out of this receiver (<i>amp</i>) or <i>through</i> to a TV or flat panel TV. When THROUGH is selected, no sound is output from this receiver.	AMPLIFIER <i>THROUGH</i>
A. DELAY (Auto delay)	This feature automatically corrects the audio-to-video delay between components connected with an HDMI cable. The audio delay time is set depending on the operational status of the display connected with an HDMI cable. The video delay time is automatically adjusted according to the audio delay time. ^h	OFF <i>ON</i>

Setting	What it does	Option(s)
C. WIDTHⁱ (Center Width) (Applicable only when using a center speaker)	Provides a better blend of the front speakers by spreading the center channel between the front right and left speakers, making it sound wider (higher settings) or narrower (lower settings).	0 to 7 Default: 3
DIMENSIONⁱ	Adjusts the depth of the surround sound balance from front to back, making the sound more distant (minus settings), or more forward (positive settings).	-3 to +3 Default: 0
PANORAMAⁱ	Extends the front stereo image to include the surround speakers for a 'wraparound' effect.	OFF <i>ON</i>
C. IMAGEⁱ (Center Image) (Applicable only when using a center speaker)	Adjusts the center image to create a wider stereo effect with vocals. Adjust the effect from 0 (all center channel sent to front right and left speakers) to 10 (center channel sent to the center speaker only).	0 to 10 Defaults: Neo:6 MUSIC: 3 Neo:6 CINEMA: 10
EFFECT	Sets the effect level for the currently selected Advanced Surround or ALC mode (each mode can be set separately).	10 to 90

a. When **EQ OFF** is selected, the MCACC indicator does not light.

b. This setting is only displayed when the listening mode is Stereo, Auto surround (STEREO) or ALC (STEREO).

c. The adjustment can be made only when **TONE** is set to **ON**.

d. With the **iPod/USB** input function, by default **S.RTRV** is set to **ON**.

e. The initially set **AUTO** is only available for Dolby TrueHD signals. Select **MAX** or **MID** for signals other than Dolby TrueHD.

f. You shouldn't have any problems using this with most SACD discs, but if the sound distorts, it is best to switch the gain setting back to **0** dB.

g. • HDMI Audio setting cannot be switched while performing synchronized amp mode operations.

• The synchronized amp mode must be turned on in order to play the receiver's HDMI audio and video input signals from the TV with the receiver's power in the standby mode. See *Synchronized amp mode* on page 63.

h. This feature is only available when the connected display supports the automatic audio/video synchronizing capability ('lipsync') for HDMI. If you find the automatically set delay time unsuitable, set **A. DELAY** to **OFF** and adjust the delay time manually. For more details about the lipsync feature of your display, contact the manufacturer directly.

i. Only when listening to 2-channel sources in Dolby Pro Logic IIx Music/Dolby Pro Logic II Music mode.

j. Only when listening to 2-channel sources in Neo:6 MUSIC/CINEMA mode.

Setting the Video options

There are a number of additional picture settings you can make using the **VIDEO PARAMETER** menu. The defaults, if not stated, are listed in bold.



Important

- Note that if an option cannot be selected on the **VIDEO PARAMETER** menu, it is unavailable due to the current source, setting and status of the receiver.
- These functions do not affect HDMI inputs.

1 Press **RECEIVER, then press **VIDEO PARAMETER**.**

2 Use **↑/↓ to select the setting you want to adjust.**

Depending on the current status/mode of the receiver, certain options may not be able to be selected. Check the table below for notes on this.

3 Use **←/→ to set it as necessary.**

See the table below for the options available for each setting.¹

4 Press **RETURN to confirm and exit the menu.**

Setting	What it does	Option(s)
V. CONV (Digital Video Conversion)	Converts video signals for output from the MONITOR OUT jacks (including HDMI OUT connector) for all video types (see page 22).	ON <i>OFF</i>
RES^a (Resolution) <i>*VSX-1019AH model only</i>	Specifies the output resolution of the video signal (when analog video input signals are output at the HDMI OUT connector, select this according to the resolution of your monitor and the images you wish to watch).	AUTO <i>PURE</i> <i>480p/576p</i> <i>720p</i> <i>1080i</i> <i>1080p</i>
ASP^b (Aspect) <i>*VSX-1019AH model only</i>	Specifies the aspect ratio when analog video input signals are output at the HDMI output. Make your desired settings while checking each setting on your display (if the image doesn't match your monitor type, cropping or black bands appear).	THROUGH <i>NORMAL</i>
IP CONV^{c,d} (I/P Converter) <i>*VSX-919AH model only</i>	480i/576i analog video signals are converted to progressive signals for output. When set to AUTO , the signals are output with the optimum setting for the connected display by HDMI. When set to ON , the signals are up-converted to 480p/576p for output. When set to OFF , the signals are not converted for output.	AUTO <i>ON</i> <i>OFF</i>

Note

- ¹ • All of the setting items can be set for each input function.
• Setting items other than **V. CONV** can only be selected when **V. CONV** is set to **ON**.

Setting	What it does	Option(s)
PCINEMA ^{c,e} (PureCinema)	This setting optimizes the picture for film material when the video output is set to progressive. Usually set to AUTO ; but try switching to OFF if the picture appears unnatural. Additionally, certain PAL movie video (576i, 25 frames/second STB video output or DVD disc playback, etc.) that contain film progressive material cannot be recognized as such by this receiver. In such instances, if you choose PAL , PureCinema mode is activated.	AUTO <hr/> <i>PAL</i> <hr/> <i>OFF</i>
P.MOTION ^c (Progressive Motion)	Adjusts the motion and still picture quality when video output is set to progressive.	-4 to +4 Default: 0
YNR ^c	Adjusts the amount of noise reduction (NR) applied to the Y (brightness) component.	0 to +8 Default: 0
DETAIL ^c	Adjusts how sharp edges appear.	-4 to +4 Default: 0
SHARP ^{c,f} (Sharpness)	Adjusts the sharpness of the high-frequency (detailed) elements in the picture.	-4 to +4 Default: 0
BRIGHT ^c (Brightness)	Adjusts the overall brightness.	-6 to +6 Default: 0
CONTRAST ^c	Adjusts the contrast between light and dark.	-6 to +6 Default: 0
HUE ^c	Adjusts the red/green balance.	-6 to +6 Default: 0
CHROMA ^c (Chroma Level)	Adjusts saturation from dull to bright.	-6 to +6 Default: 0

- a. • When set to a resolution with which the TV (monitor) is not compatible, no picture is output. Also, in some cases no picture will be output due to copyright protection signals. In this case, change the setting.
- When **AUTO** is selected, the resolution is selected automatically according to the capacity of the TV (monitor) connected by HDMI. When **PURE** is selected, the signals are output with the same resolution as when input (At this time, video signals are only output from the same type of terminals to which they were input).
 - When a display is connected by HDMI, if this is set to something other than **PURE** and 480i/576i analog signals are input, 480p/576p signals are output from the component output terminals.
- b. • If the image doesn't match your monitor type, adjust the aspect ratio on the source component or on the monitor.
- **NORMAL** setting is only displayed when 480i/p or 576i/p video signals are being input.
- c. This setting is only displayed when 480i or 576i video signals are being input.
- d. If the picture does not display properly when **AUTO** or **PAL** is selected, select **OFF**.
- e. If the picture does not display properly when **PAL** is selected, select **AUTO** or **OFF**.
- f. This setting is ineffective for HDMI output, from composite and component video inputs.

Switching the speaker system

If you selected **Speaker B** in *Surround back speaker setting* on page 94, three speaker system settings are possible using **SPEAKERS**. If you selected **Normal**, **Front Bi-Amp** or **ZONE 2**, the button will simply switch your main speaker system on or off. The options below are for the **Speaker B** setting only.¹

• Use **SPEAKERS** on the front panel to select a speaker system setting.

As mentioned above, if you have selected **Normal**, the button will simply switch your main speaker system (A) on or off.

Press repeatedly to choose a speaker system option:

- **SP▶A** – Sound is output from speaker system A and the same signal is output from the pre-out terminals.
- **SP▶B** – Sound is output from the two speakers connected to speaker system B. Multichannel sources will not be heard. The same signal is output from the surround back channel pre-out terminals.
- **SP▶AB** – Sound is output from speaker system A (up to 5 channels, depending on the source), the two speakers in speaker system B, and the subwoofer. The sound from speaker system B will be the same as the sound from speaker system A (multichannel sources will be downmixed to 2 channels).
- **SP▶** (off) – No sound is output from the speakers. The same sound is output from the pre-out terminals (including from your subwoofer, if connected) as when selecting speaker system A (above).

Using the MULTI-ZONE controls

The following steps use the front panel controls to adjust the sub zone volume and select sources. See *MULTI-ZONE remote controls* on page 70.

1 Press the **MULTI-ZONE ON/OFF** button on the front panel.

Each press selects a MULTI-ZONE option:

- **ZONE 2 ON** – Switches the MULTI-ZONE feature on
- **MULTI ZONE OFF** – Switches the MULTI-ZONE feature off

The **MULTI-ZONE** indicator lights when the MULTI-ZONE control has been switched ON.

2 Press **MULTI-ZONE CONTROL** on the front panel.

- When the receiver is on,² make sure that any operations for the sub zone are done while **ZONE 2** shows in the display. If this is not showing, the front panel controls affect the main zone only.

3 Use the **INPUT SELECTOR** dial to select the source for the sub zone.

For example, **ZONE 2 CD-R** sends the source connected to the **CD-R** inputs to the sub room (**ZONE 2**).

- If you select **TUNER**, you can use the tuner controls to select a preset station (see *Saving station presets* on page 52 if you're unsure how to do this).³
- *VSX-919AH model only:* iPod/USB and SIRIUS Radio function cannot be selected for the MULTI-ZONE feature.

Note

- 1 • The subwoofer output depends on the settings you made in *Manual speaker setup* on page 94. However, if **SP▶B** is selected above, no sound is heard from the subwoofer (the LFE channel is not downmixed).
 - Depending on the settings in *Surround back speaker setting* on page 94 output from the surround back pre-out terminals may change.
 - All speaker systems (except **Speaker B** connections) are switched off when headphones are connected.
- 2 If the receiver is in standby, the display is dimmed, and **ZONE 2 DVD** for example shows in the display.
- 3 The tuner cannot be tuned to more than one station at a time. Therefore, changing the station in one zone also changes the station in the other zone. Please be careful not to change stations when recording a radio broadcast.

4 Use the MASTER VOLUME dial to adjust the volume for the sub zone.

This is only possible if you selected the **Variable** volume control in *ZONE Audio Setup* on page 99.¹

5 When you're finished, press MULTI-ZONE CONTROL again to return to the main zone controls.

You can also press the **MULTI-ZONE ON/OFF** button on the front panel to switch off all output to the sub zone.²

MULTI-ZONE remote controls

Set the MULTI-ZONE operation switch to **ZONE 2** to operate the corresponding zone.

The following table shows the possible MULTI-ZONE remote controls:

Button	What it does
	Switches on/off power in the sub zone.
INPUT SELECT	Use to select the input function in the sub zone.
Input function buttons	Use to select the input function directly (this may not work for some functions) in the sub zone.
MASTER VOLUME +/-	Use to set the listening volume in the sub zone.

Making an audio or a video recording

You can make an audio or a video recording from the built-in tuner, or from an audio or video source connected to the receiver (such as a CD player or TV).³

Keep in mind you can't make a digital recording from an analog source or vice-versa, so make sure the components you are recording to/from are hooked up in the same way (see *Connecting your equipment* on page 14 for more on connections).

Since the video converter is not available when making recordings (from the video **OUT** jacks) make sure to use the same type of video cable for connecting your recorder as you used to connect your video source (the one you want to record) to this receiver. For example, you must connect your recorder using Component video if your source has also been connected using Component video.

For more information about video connections, see *Connecting a HDD/DVD recorder, VCR and other video sources* on page 28.

1 Select the source you want to record.

Use the input function buttons (or **INPUT SELECT**).

- If necessary, press **RECEIVER**, then press **SIGNAL SEL** to select the input signal corresponding to the source component (see *Choosing the input signal* on page 58 for more on this).

2 Prepare the source you want to record.

Tune to the radio station, load the CD, video, DVD etc.

Note

- 1 The volume levels of the main and sub zone are independent.
- 2 • You won't be able to switch the main zone off completely unless you've switched off the MULTI-ZONE control first.
 - If you don't plan to use the MULTI-ZONE feature for a while, turn off the power in both the sub and main rooms so that this receiver is in standby.
- 3 • The receiver's volume, Audio parameters (the tone controls, for example), and surround effects have no effect on the recorded signal.
 - Some digital sources are copy-protected, and can only be recorded in analog.
 - Some video sources are copy-protected. These cannot be recorded.

3 Prepare the recorder.

Insert a blank tape, MD, video etc. into the recording device and set the recording levels. Refer to the instructions that came with the recorder if you are unsure how to do this. Most video recorders set the audio recording level automatically—check the component's instruction manual if you're unsure.

4 Start recording, then start playback of the source component.

Reducing the level of an analog signal

The input attenuator lowers the input level of an analog signal when it's too strong. You can use this if you find that the **OVER** indicator lights often or you can hear distortion in the sound.¹

- Press **RECEIVER**, then press **A.ATT** to switch the input attenuator on or off.

Using the sleep timer

The sleep timer switches the receiver into standby after a specified amount of time so you can fall asleep without worrying about the receiver being left on all night. Use the remote control to set the sleep timer.

- Press **RECEIVER**, then press **SLEEP** repeatedly to set the sleep time.



- You can check the remaining sleep time at any time by pressing **SLEEP** once. Pressing repeatedly will cycle through the sleep options again.²

Note

- 1 The attenuator isn't available with digital sources, or when using the Stream Direct (ANALOG DIRECT) modes.
- 2 • You can also switch off the sleep timer simply by switching off the receiver.
 - The sleep timer is valid for all zones. If any zone is on, the sleep timer continues functioning.
- 3 If the Pure Direct mode is switched on, some settings above will show **OFF**, even though they are on.

Dimming the display

You can choose between four brightness levels for the front panel display. Note that when selecting sources, the display automatically brightens for a few seconds.

- Press **RECEIVER**, then press **DIMMER** repeatedly to change the brightness of the front panel display.

Checking your system settings

Use the status display screen to check your current settings for features such as surround back channel processing and your current MCACC preset.

1 Press **RECEIVER**, then press **STATUS** to check the system settings.

These appear on the front panel display.³

The front panel display shows each of the following settings for three seconds each:

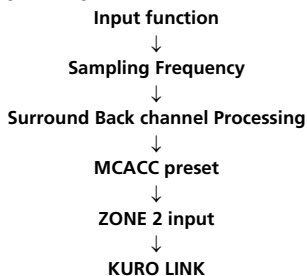

2 When you're finished, press **STATUS** again to switch off the display.

Resetting the system

Use this procedure to reset all the receiver's settings to the factory default. Use the front panel controls to do this. Set **MULTI-ZONE** to **OFF**.

- Disconnect the iPod and USB memory device from the receiver beforehand.

1 Switch the receiver into standby.

2 While holding down ENTER on the front panel, press \odot STANDBY/ON.

The display shows **RESET ◀ NO ▶**.

3 Select 'RESET' using PRESET +/-, then press ENTER on the front panel.

The display shows **RESET? OK**.

4 Press ENTER to confirm.

OK appears in the display to indicate that the receiver has been reset to the factory default settings.

- Note that all settings will be saved, even if the receiver is unplugged.

Default system settings

Setting	Default
Digital Video Conversion	ON
SPEAKERS	A
Surround Back System	Normal
Speaker System	Front
	Center
	Surr
	SB
	SW
Crossover	80 Hz
X-Curve	OFF
DIMMER	brightest
Inputs	
See <i>Input function default and possible settings</i> on page 40.	
MULTI-ZONE	
Zone 2 Volume Level	Variable
Zone 2 Volume	-60 dB
HDMI	
HDMI Audio	Amp

Setting	Default
KURO LINK	ON
DSP	
Surround back channel Processing	ON
Phase Control	ON
Sound Retriever	iPod/USB function
	Other functions
Sound Delay	0.0 frame
Dual Mono	CH1
DRC	AUTO
SACD Gain	0 dB
LFE Attenuate	0 dB
Auto delay	OFF
UP Mix	ON
Digital Safety	OFF
Effect Level	ExtendedStereo
	Other modes
<input checked="" type="checkbox"/> PL II Music Options	Center Width
	Dimension
	Panorama
Neo:6 Options	Center Image
	Neo:6 MUSIC: 3
	Neo:6 CINEMA: 10
All Inputs	Listening Mode (2 ch)
	Listening Mode (x ch)
	Listening Mode (HP)
See also <i>Setting the Audio options</i> on page 64 for other default DSP settings.	
MCACC	
MCACC Position Memory	M1: MEMORY 1
Channel Level (M1 to M6)	0.0 dB
Speaker Distance (M1 to M6)	10'00"
Standing Wave (M1 to M6)	ATT of all channels/filters
	SWch Wide Trim
EQ Data (M1 to M6)	All channels/bands
	EQ Wide Trim

Chapter 9:

Controlling the rest of your system

Operating multiple receivers

The remote control included with this receiver can be used to operate up to three other receivers (of the same model as this receiver) in addition to this receiver. The receiver to be operated is switched by inputting the preset code to set the remote control setting.

- Set the remote modes on the receivers before using this function (see *Remote Control Mode Setup* on page 101).

1 Check the operation selector switch to MAIN.

2 Press **RECEIVER.**

3 Press and hold REMOTE SETUP, then release it after the LED flashes twice.

4 Use the number buttons to enter the 5-digit preset code (see below).

- Receiver 1: **6 1 9 3 5** (Default)
- Receiver 2: **6 2 6 3 0**
- Receiver 3: **6 2 6 3 1**
- Receiver 4: **6 2 6 3 2**

When the preset code is fully input, the LED flashes once to indicate that the setting is completed.

To operate another receiver, start over from step 1 to input its preset code.

Setting the remote to control other components

Most components can be assigned to one of the input function buttons (such as **DVD** or **CD**) using the component's manufacturer preset code stored in the remote.

However, there are cases where only certain functions may be controllable after assigning the proper preset code, or the codes for the manufacturer in the remote control will not work for the model that you are using.



Note

- You can cancel or exit any of the steps by pressing **RECEIVER**. To go back a step, press **RETURN**.
- After one minute of inactivity, the remote automatically exits the operation.

Selecting preset codes directly

1 Press the input function button for the component you want to control.¹

When assigning preset codes to **TV CONTROL**, press **TV CTRL** here.

2 Press and hold REMOTE SETUP, then release it after the LED flashes twice.

3 Use the number buttons to enter the 5-digit preset code.

See *Preset code list* on page 116.

Note

¹You can't assign **RECEIVER**, **TUNER**, **iPod/USB** or **SIRIUS**.

When the preset code is fully input, the LED flashes once to indicate that the setting is completed.

4 Repeat steps 1 through 3 for the other components you want to control.

To try out the remote control, switch the component on or off (into standby) by pressing **⏻ SOURCE**. If it doesn't seem to work, select the next code from the list (if there is one).

Resetting the remote control presets

This will erase all preset remote control preset codes and programmed buttons.

1 Check the operation selector switch to **MAIN**.

2 Press **RECEIVER**.

3 Press and hold **REMOTE SETUP**, then release it after the LED flashes twice.

4 Use the number buttons to enter **9, 8, 1**.

The LED flashes four times to indicate that the resetting is completed.

Default preset codes

Input function button	Preset code
DVD	3 1 5 7 1
BD	3 2 4 4 2
DVR	2 2 3 0 6
HDMI	3 2 4 4 2
TV	1 4 0 0 1
CD	7 0 4 6 8
CD-R	7 1 0 8 7
VIDEO	2 0 0 5 8
TV CTRL	1 4 0 0 1
RECEIVER	6 1 9 3 5

Controls the components

This remote control can control components after entering the proper codes or teaching the receiver the commands (see *Setting the remote to control other components* on page 73 for more on this). Use the input function buttons to select the component.

- The **TV CONTROL** buttons on the remote control are dedicated to control the TV assigned to the **TV CTRL** button. If you have two TVs, assign the main TV to the **TV CTRL** button.

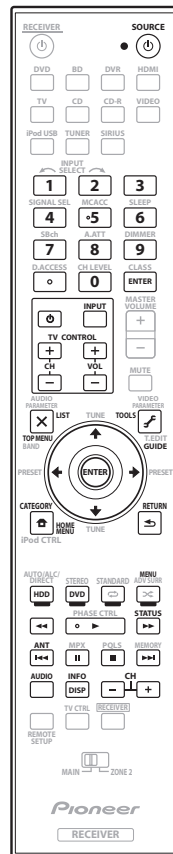

Button(s)	TV	TV (Monitor)	BD/DVD	HDD/DVR	VCR	SAT/CATV
SOURCE	POWER ON/ OFF	POWER ON/ OFF	POWER ON/ OFF	POWER ON/ OFF	POWER ON/ OFF	POWER ON/ OFF
Number buttons	<i>numerics</i>	<i>numerics</i>	<i>numerics</i>	<i>numerics</i>	<i>numerics</i>	<i>numerics</i>
• (dot)	• (dot)	KURO LINK	CLEAR	+	-	*
ENTER (CLASS)	ENTER	CH ENTER	ENTER	ENTER	-	ENTER
	EXIT/INFO	EXIT	TOP MENU	TOP MENU	-	LIST
	TOOLS/ GUIDE/EPG	USER MENU	TOOLS	GUIDE	-	GUIDE
					-	
ENTER	ENTER	ENTER	ENTER	ENTER	-	ENTER
	HOME MENU	HOME MENU	HOME MENU	HOME MENU	-	HOME/ MENU
	RETURN	RETURN	RETURN	RETURN	-	RETURN
HDD (Red)	<i>Red</i>	<i>Red</i>	-	HDD	-	<i>Red</i>
DVD (Green)	<i>Green</i>	<i>Green</i>	-	DVD	-	<i>Green</i>
(Yellow)	<i>Yellow</i>	<i>Yellow</i>	-	VCR	-	<i>Yellow</i>
(Blue)	<i>Blue</i>	<i>Blue</i>	MENU	MENU	-	<i>Blue</i>
	-	-				
	-	AUTO SETUP				
	-	FREEZE				
	-	-				
	-	-				
	ANT	AV SELECTION			-	
	-	SCREEN SIZE			-	
AUDIO	AUDIO	AUDIO	AUDIO	AUDIO	AUDIO	AUDIO
DISP	DISPLAY	DISPLAY	DISPLAY	DISPLAY	-	DISPLAY/ INFO
CH +/-	CH+/-	CH+/-	-	CH+/-	CH+/-	CH+/-
+	-	-	-	-	-	RECORD

Button(s)	LD	CD/CD-R/ SACD	MD/DAT	TAPE
SOURCE	POWER ON/ OFF	POWER ON/ OFF	POWER ON/ OFF	POWER ON/ OFF
Number buttons	<i>numerics</i>	<i>numerics</i>	<i>numerics</i>	-
• (<i>dot</i>)	+10	>10/CLEAR	CLEAR ^b	CLEAR
ENTER (CLASS)	ENTER	DISK/ENTER	OPEN/CLOSE ^b	ENTER
	TOP MENU	-	-	MS←
	-	LEGATO LINK ^a	-	MS→
		-	-	
ENTER	ENTER	-	-	-
	-	SACD SETUP ^a	-	-
	RETURN	-	-	-
AUDIO	AUDIO	PURE AUDIO ^a	-	-
DISP	DISPLAY/ INFO	TIME ^a	-	-

a. Controls for SACD.

b. Controls for MD.

Button(s)	TV (Projector)
SOURCE	POWER ON
1	MOVIE
2	STANDARD
3	DYNAMIC
4	USER1
5	USER2
6	USER3
7	COLOR+
8	SHARP+
9	GAMMA
0	COLOR-
• (<i>dot</i>)	SHARP-
ENTER (CLASS)	COLOR TEMP
	EXIT
	INFO
ENTER	ENTER
	TEST
	HIDE
	MENU
	HDMI1
	HDMI2
	COMP.
	VIDEO
	S-VIDEO
	BRIGHT-
	BRIGHT+
AUDIO	POWER OFF
DISP	ASPECT
CH +/-	CONTRAST+/-

Chapter 10:

The Advanced MCACC menu

Making receiver settings from the Advanced MCACC menu

The Advanced MCACC (Multi Channel ACoustic Calibration) system was developed in Pioneer's laboratories with the aim of making it possible for home users to perform adjustments of the same level as in a studio easily and with high precision. The acoustic characteristics of the listening environment are measured and the frequency response is calibrated accordingly to allow high precision, automatic analysis and optimal calibration of the sound field to bring it closer to a studio environment than ever before. Furthermore, while it was previously difficult to eliminate standing waves, this receiver is equipped with a standing wave control function using a unique process to perform acoustic analysis and reduce their influence.

This section describes how to calibrate the sound field automatically and fine-adjust the sound field data manually.

1 Switch on the receiver and your TV.

Use **RECEIVER** to switch on.¹

- If headphones are connected to the receiver, disconnect them.

2 Press **RECEIVER** on the remote control, then press **HOME MENU**.²

A Graphical User Interface (GUI) screen appears on your TV. Use **↑/↓/←/→** and **ENTER** to navigate through the screens and select menu items. Press **RETURN** to confirm and exit the current menu.

- Press **HOME MENU** at any time to exit the **HOME MENU**.

3 Select 'Advanced MCACC' from the HOME MENU, then press ENTER.

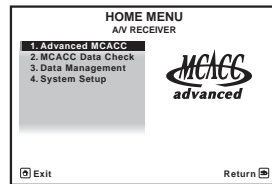

4 Select the setting you want to adjust.

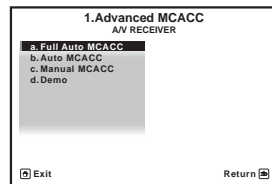

- **Full Auto MCACC** – See *Automatically setting up for surround sound (Auto MCACC)* on page 37 for a quick and effective automatic surround setup.
- **Auto MCACC** – See *Automatic MCACC (Expert)* on page 78 for a more detailed MCACC setup.
- **Manual MCACC** – Fine-tunes your speaker settings and customize the Acoustic Calibration EQ (see *Manual MCACC setup* on page 82).
- **Demo** – No settings are saved and no errors occur. When the speakers are connected to this receiver, the test tone is output repeatedly. Press **RETURN** to cancel the test tone.

Note

¹ Make sure not to switch off the power when using the **HOME MENU**.

² You can't use the **HOME MENU** when the iPod/USB or SIRIUS Radio input function is selected. When you set **ZONE 2** to **ON** (page 69), you can't use the **HOME MENU**.

Automatic MCACC (Expert)

If your setup requires more detailed settings than those provided in *Automatically setting up for surround sound (Auto MCACC)* on page 37, you can customize your setup options below. You can calibrate your system differently for up to six different MCACC presets¹, which are useful if you have different listening positions depending on the type of source (for example, watching movies from a sofa, or playing a video game close to the TV).²



Important

- Make sure the microphone/speakers are not moved during the Auto MCACC Setup.
- Using the Auto MCACC Setup will overwrite any existing settings for the MCACC preset you select.³
- The screen saver will automatically appear after five minutes of inactivity.



CAUTION

- The test tones used in the Auto MCACC Setup are output at high volume.

THX®

THX is a trademark of THX Ltd., which may be registered in some jurisdictions. All rights reserved.

1 Select 'Auto MCACC' from the Advanced MCACC menu, then press ENTER.

If the **Advanced MCACC** screen is not displayed, refer to *Making receiver settings from the Advanced MCACC menu* on page 77.

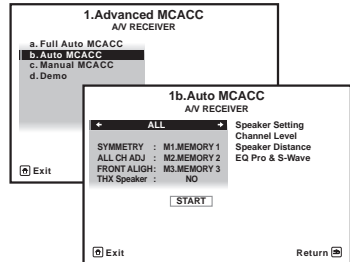

2 Select the parameters you want to set.

Use **↑/↓** to select the item, then use **←/→** to set.

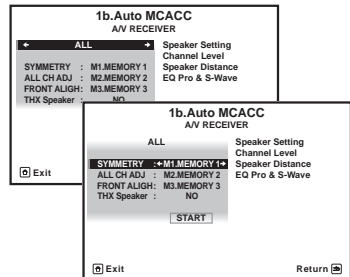

Note

- 1 These are stored in memory and referred to as **MEMORY1** to **MEMORY6** until you rename them in *Data Management* on page 91.
- 2 You may also want to have separate calibration settings for the same listening position, depending on how you're using your system.
- 3 Except in cases where you are only adjusting one parameter (i.e. channel level) from the **Auto MCACC** menu (step 2).

- **Auto MCACC** – The default is **ALL** (recommended), but you can limit the system calibration to only one setting (to save time) if you want.¹ The available options are **ALL**, **Keep SP System**,² **Speaker Setting**, **Channel Level**, **Speaker Distance** and **EQ Pro & S-Wave**.
- **EQ Type** (only available when the **Auto MCACC Menu** above is **EQ Pro & S-Wave**) – This determines how the frequency balance is adjusted.

After a single calibration is performed, each of the following three correction curves can be stored separately in the MCACC memory.

SYMMETRY (default) implements symmetric correction for each pair of left and right speakers to flatten the frequency-amplitude characteristics. **ALL CH ADJ** is a 'flat' setting where all the speakers are set individually so no special weighting is given to any one channel. **FRONT ALIGN**³ sets all speakers in accordance with the front speaker settings (no equalization is applied to the front left and right channels).

- **THX Speaker** (only available when the **Auto MCACC Menu** above is **ALL** or **Speaker Setting**) – Select **YES** if you are using THX speakers (set all speakers to **SMALL**), otherwise leave it set to **NO**.
- **STAND.WAVE Multi-Point** (only available when the **Auto MCACC Menu** above is **EQ Pro & S-Wave**) – In addition to measurements at the listening position, you can use two more reference points for which test tones will be analyzed for standing waves. This is useful if you want to get a balanced 'flat' calibration for several

seating positions in your listening area.⁴ Place the microphone at the reference point indicated on-screen and note *the last microphone placement will be at your main listening position*:

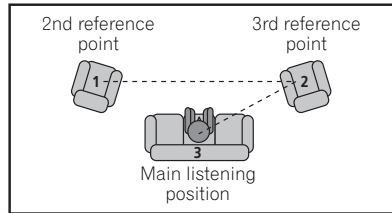

3 Connect the microphone to the MCACC SETUP MIC jack on the front panel.

- Push down on the **PUSH OPEN** tab to access the **MCACC SETUP MIC** jack.

Make sure there are no obstacles between the speakers and the microphone.

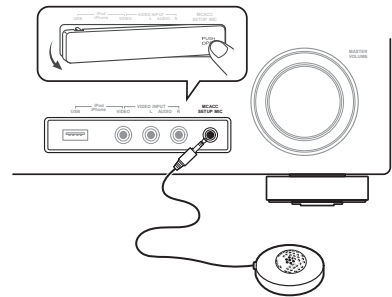

If you have a tripod, use it to place the microphone so that it's about ear level at your normal listening position. Otherwise, place the microphone at ear level using a table or a chair.

Note

- 1 • The **EQ Pro & S-Wave** measurement is also taken when **Keep SP System** or **EQ Pro & S-Wave** is selected. See *Acoustic Calibration EQ Professional* on page 86 for more on this.
 - Either effect of Acoustic Calibration EQ Professional and Standing Wave can be switched on and off in the respective MCACC preset. For details, see *Setting the Audio options* on page 64.
- 2 The **Keep SP System** option allows you to calibrate your system while leaving your current speaker setting (page 95) unchanged.
- 3 If you selected **ALL** as your **Auto MCACC** menu, you can specify the MCACC preset where you want to save the **ALL CH ADJ** and **FRONT ALIGN** settings.
- 4 Switch the **Multi-Point** setting **NO** if you only use one listening position.

4 When you're finished settings the options, select **START** then press **ENTER**.

5 Follow the instructions on-screen.

- Make sure the microphone is connected.
- If you're using a subwoofer, it is automatically detected every time you switch on the system. Make sure it is on and the volume is turned up.
- See *Problems when using the Auto MCACC Setup* on page 39 for notes regarding high background noise levels and other possible interference.

6 Wait for the Auto MCACC Setup to finish outputting test tones.

A progress report is displayed on-screen while the receiver outputs test tones to determine the speakers present in your setup. Try to be as quiet as possible while it's doing this.

- Do not adjust the volume during the test tones. This may result in incorrect speaker settings.
- With error messages (such as **Too much ambient noise!** or **Check microphone**) select **RETRY** after checking for ambient noise (see *Problems when using the Auto MCACC Setup* on page 39) and verifying the mic connection. If there doesn't seem to be a problem, you can simply select **GO NEXT** and continue.

7 If necessary, confirm the speaker configuration in the GUI screen.¹

The configuration shown on-screen should reflect the actual speakers you have.

If no operations are performed for 10 seconds while the speaker configuration check screen is being displayed, the Auto MCACC Setup will resume automatically. In this case, you don't need to select '**OK**' and press **ENTER** in step 8.

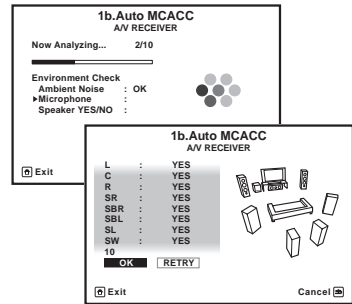

- If you see an **ERR** message (or the speaker configuration displayed isn't correct), there may be a problem with the speaker connection. If selecting **RETRY** doesn't work, turn off the power and check the speaker connections. If there doesn't seem to be a problem, you can simply use **↑/↓** to select the speaker and **←/→** to change the setting and continue.
- If **Reverse Phase** is displayed, the speaker's wiring (+ and -) may be inverted. Check the speaker connections.² If the connections were wrong, turn off the power, disconnect the power cable, then reconnect properly. After this, perform the Full Auto MCACC procedure again.

Note

- ¹ This screen is only shown if you selected **ALL** or **Speaker Setting** from the **Auto MCACC** menu.
- ² If the speaker is not pointed to the microphone (listening position) or when using speakers that affect the phase (dipole speakers, reflective speakers, etc.), **Reverse Phase** may be displayed even if the speakers are properly connected. If this happens, select **GO NEXT** and continue.

8 Make sure 'OK' is selected, then press ENTER.

A progress report is displayed on-screen while the receiver outputs more test tones to determine the optimum receiver settings for channel level, speaker distance, and Acoustic Calibration EQ.

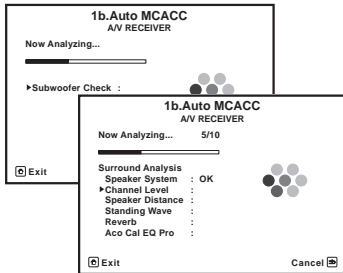

Again, try to be as quiet as possible while this is happening. It may take 3 to 7 minutes.

- If you selected a **STAND.WAVE Multi-Point** setup (in step 2), you will be asked to place the mic at the 2nd and 3rd reference points before finally placing it at your main listening position.

9 The Auto MCACC Setup procedure is completed and the Advanced MCACC menu reappears automatically.

The settings made in the Auto MCACC Setup should give you excellent surround sound from your system, but it is also possible to adjust these settings manually using the **Manual MCACC** setup menu (starting below) or **Manual SP Setup** menu (starting on page 94).¹

You can also choose to view the settings by selecting individual parameters from the **MCACC Data Check** screen:

- **Speaker Setting** – The size and number of speakers you've connected (see page 95 for more on this)
- **Channel Level** – The overall balance of your speaker system (see page 83 or 96 for more on this)
- **Speaker Distance** – The distance of your speakers from the listening position (see page 83 or 97 for more on this)²
- **Standing Wave** – Filter settings to control lower 'boomy' frequencies (see page 85 for more on this)
- **Acoustic Cal EQ** – Adjustments to the frequency balance of your speaker system based on the acoustic characteristics of your room (see page 85 for more on this)

Press **RETURN** after you have finished checking each screen. When you're finished, select **RETURN** to go back to the **HOME MENU**.

Be sure to disconnect the microphone from this receiver upon completion of the Auto MCACC Setup.

Note

- 1 Depending on the characteristics of your room, sometimes identical speakers with cone sizes of around 12 cm (5 inches) will end up with different size settings. You can correct the setting manually using the *Manual speaker setup* on page 94.
 - The subwoofer distance setting may be farther than the actual distance from the listening position. This setting should be accurate (taking delay and room characteristics into account) and generally does not need to be changed.
 - If Auto MCACC Setup measurement results are incorrect due to the interaction of the speakers and viewing environment, we recommend adjusting the settings manually.
- 2 Since the distance measurements have been set according to the sound characteristics of your speakers, there are cases where (for optimal surround sound) the actual distance may differ from the speaker distance setting.

Manual MCACC setup

You can use the settings in the **Manual MCACC** setup menu to make detailed adjustments when you're more familiar with the system. Before making these settings, you should have already completed *Automatically setting up for surround sound (Auto MCACC)* on page 37.

You only need to make these settings once (unless you change the placement of your current speaker system or add new speakers).

CAUTION

- The test tones used in the **Manual MCACC** setup are output at high volume.

Important

- You will need to first specify the MCACC preset you want to adjust by pressing **MCACC** before pressing **HOME MENU** (step 2 in *Making receiver settings from the Advanced MCACC menu* on page 77).
- For some of the settings below, you'll have to connect the setup microphone to the front panel and place it about ear level at your normal listening position. Press **HOME MENU** to display the **HOME MENU** before you connect the microphone to this receiver. If the microphone is connected while the **HOME MENU** is not being displayed, the display will change to the **Full Auto MCACC** under **Advanced MCACC**.
- See *Problems when using the Auto MCACC Setup* on page 39 for notes regarding high background noise levels and other possible interference.
- If you're using a subwoofer, switch it on and turn up the volume to the middle position.

1 Select 'Manual MCACC' from the Advanced MCACC menu.

See *Making receiver settings from the Advanced MCACC menu* on page 77 if you're not already at this screen.

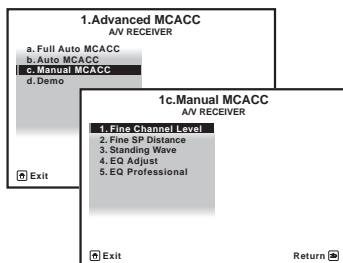

2 Select the setting you want to adjust.

If you're doing this for the first time, you might want to make these settings in order.

- **Fine Channel Level** – Make fine adjustments to the overall balance of your speaker system (see *Fine Channel Level* on page 83).
- **Fine SP Distance** – Make precise delay settings for your speaker system (see *Fine Speaker Distance* on page 83).
- **Standing Wave** – Control overly resonant low frequencies in your listening room (see *Standing Wave* on page 85).

The last two settings are specifically for customizing the parameters explained in *Acoustic Calibration EQ Adjust* on page 85:

- **EQ Adjust** – Manually adjust the frequency balance of your speaker system while listening to test tones (see *Acoustic Calibration EQ Adjust* on page 85).
- **EQ Professional** – Calibrate your system based on the direct sound coming from the speakers and make detailed settings according to your room's reverb characteristics (see *Acoustic Calibration EQ Professional* on page 86).

Fine Channel Level

- Default setting: **0.0dB** (all channels)

You can achieve better surround sound by properly adjusting the overall balance of your speaker system. You can adjust the Channel Level of each speaker in 0.5 dB increments. The following setting can help you make detailed adjustments that you may not achieve using the *Manual speaker setup* on page 94.

1 Select 'Fine Channel Level' from the Manual MCACC setup menu.

The volume increases to the 0.0 dB reference level.

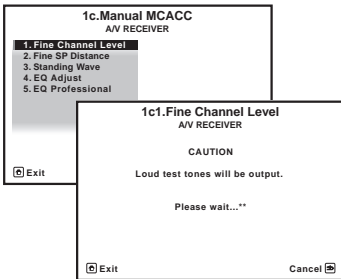

2 Adjust the level of the left channel.

This will be the reference speaker level, so you may want to keep the level around **0.0dB** so that you'll have plenty of room to adjust the other speaker levels.

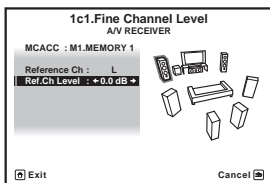

- After pressing **ENTER**, test tones will be output.

3 Select each channel in turn and adjust the levels (+/-10.0 dB) as necessary.

Use **←/→** to adjust the volume of the speaker you selected to match the reference speaker. When it sounds like both tones are the same volume, press **↓** to confirm and continue to the next channel.

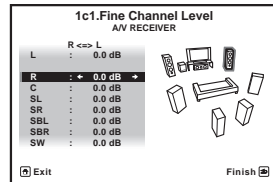

- For comparison purposes, the reference speaker will change depending on which speaker you select.
- If you want to go back and adjust a channel, simply use **↑/↓** to select it.

4 When you're finished, press RETURN.

You will return to the **Manual MCACC** setup menu.

Fine Speaker Distance

- Default setting: **10'00"** (all speakers)

For proper sound depth and separation with your system, it is necessary to add a slight bit of delay to some speakers so that all sounds will arrive at the listening position at the same time. You can adjust the distance of each speaker in half inch increments. The following setting can help you make detailed adjustments that you may not achieve using the *Manual speaker setup* on page 94.

1 Select 'Fine SP Distance' from the Manual MCACC setup menu.

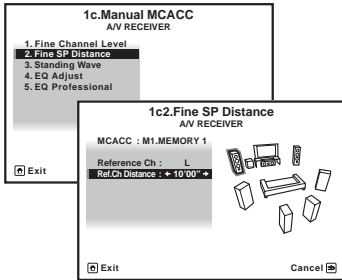

2 Adjust the distance of the left channel from the listening position.

3 Select each channel in turn and adjust the distance as necessary.

Use \leftarrow/\rightarrow to adjust the delay of the speaker you selected to match the reference speaker. The delay is measured in terms of speaker distance from **0'00-1/2"** to **45'00"**.

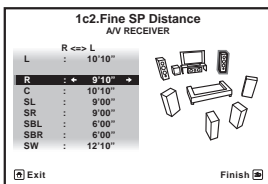

Listen to the reference speaker and use it to measure the target channel. From the listening position, face the two speakers with your arms outstretched pointing at each speaker. Try to make the two tones sound as if they are arriving simultaneously at a position slightly in front of you and between your arm span.¹

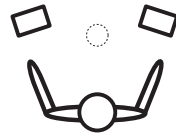

When it sounds like the delay settings are matched up, press \downarrow to confirm and continue to the next channel.

- For comparison purposes, the reference speaker will change depending on which speaker you select.
- If you want to go back and adjust a channel, simply use \uparrow/\downarrow to select it.

4 When you're finished, press RETURN.

You will return to the **Manual MCACC** setup menu.

Note

- If you can't seem to achieve this by adjusting the distance setting, you may need to change the angle of your speakers very slightly.
 - For better audibility, the subwoofer emits a continuous test tone (oscillating pulses are heard from your other speakers). Note that it may be difficult to compare this tone with the other speakers in your setup (depending on the low frequency response of the reference speaker).

Standing Wave

- Default setting: **ON**¹/**ATT 0.0dB** (all filters)

Acoustic standing waves occur when, under certain conditions, sound waves from your speaker system resonate mutually with sound waves reflected off the walls in your listening area. This can have a negative effect on the overall sound, especially at certain lower frequencies. Depending on speaker placement, your listening position, and ultimately the shape of your room, it results in an overly resonant ('boomy') sound. The Standing Wave Control uses filters to reduce the effect of overly resonant sounds in your listening area. During playback of a source, you can customize the filters used for Standing Wave Control for each of your MCACC presets.²

1 Select 'Standing Wave' from the Manual MCACC setup menu.

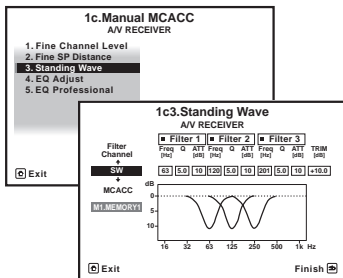

2 Adjust the parameters for the Standing Wave Control.

- **Filter Channel** – Select the channel to which you will apply the filter(s): **MAIN** (all except center channel and subwoofer), **Center** or **SW** (subwoofer).

Note

- You can switch on or off the Standing Wave and Acoustic Calibration EQ feature in the **AUDIO PARAMETER** menu. See *Setting the Audio options* on page 64 for more on this.
- Since they will be overwritten, you may want to save the standing wave settings made with the Auto MCACC Setup to another MCACC preset.
 - Standing Wave control filter settings cannot be changed during playback of sources using the HDMI connection.
 - When **Standing Wave** is selected for a MCACC preset memory where **STAND.WAVE** is set to **OFF** in the **AUDIO PARAMETER**, **STAND.WAVE ON** is automatically selected.
- When **EQ Adjust** is selected for a MCACC preset memory where **EQ** is set to **OFF** in the **AUDIO PARAMETER**, **EQ ON** is automatically selected.

- **TRIM** (only available when the filter channel above is **SW**) – Adjust the subwoofer channel level (to compensate for the difference in output post-filter).
- **Freq / Q / ATT** – These are the filter parameters where **Freq** represents the frequency you will be targeting and **Q** is the bandwidth (the higher the Q, the narrower the bandwidth, or range) of the attenuation (**ATT**, the amount of reduction to the targeted frequency).

3 When you're finished, press RETURN.

You will return to the **Manual MCACC** setup menu.

Acoustic Calibration EQ Adjust

- Default setting: **ON**³/**0.0dB** (all channels/bands)

Acoustic Calibration Equalization is a kind of room equalizer for your speakers (excluding the subwoofer). It works by measuring the acoustic characteristics of your room and neutralizing the ambient characteristics that can color the original source material (providing a 'flat' equalization setting). If you're not satisfied with the adjustment provided in *Automatically setting up for surround sound (Auto MCACC)* on page 37 or *Automatic MCACC (Expert)* on page 78, you can also adjust these settings manually to get a frequency balance that suits your tastes.

1 Select 'EQ Adjust' from the Manual MCACC setup menu.

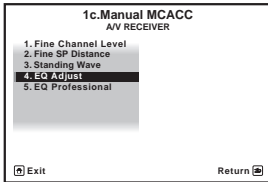

2 Select the channel(s) you want and adjust to your liking.

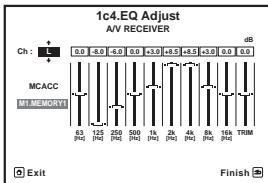

Use \uparrow/\downarrow to select the channel.

Use \leftarrow/\rightarrow to select the frequency and \uparrow/\downarrow to boost or cut the EQ. When you're finished, go back to the top of the screen and press \leftarrow to return to **Ch**, then use \uparrow/\downarrow to select the channel.

- The **OVER!** indicator shows in the display if the frequency adjustment is too drastic and might distort. If this happens, bring the level down until **OVER!** disappears from the display.

Tip

- Changing the frequency curve of one channel too drastically will affect the overall balance. If the speaker balance seems uneven, you can raise or lower channel levels using test tones with the **TRIM** feature. Use \uparrow/\downarrow to select **TRIM**, then use \leftarrow/\rightarrow to raise or lower the channel level for the current speaker.

3 When you're finished, press RETURN. You will return to the Manual MCACC setup menu.

Acoustic Calibration EQ Professional

This setup minimizes the unwanted effects of room reverberation by allowing you to calibrate your system based on the direct sound coming from the speakers.

How to use Acoustic Calibration EQ Professional

If you find that lower frequencies seem overly reverberant in your listening room (i.e. it sounds 'boomy'), or that different channels seem to exhibit different reverb characteristics (when Type A or Type B shown on the diagrams on the following applies), select **EQ Pro. & S-Wave** (or **ALL**) for the **Auto MCACC** setting in *Automatic MCACC (Expert)* on page 78 to calibrate the room automatically.

- **Type A: Reverberance of high vs. low frequencies**

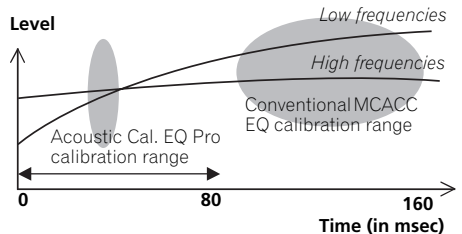

- **Type B: Reverb characteristics for different channels**

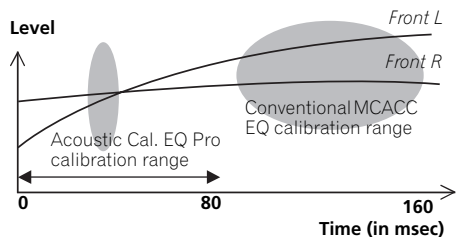

If the pattern is as shown above, select the **30-50ms** setting. If not, this setting is not necessary.

Using Acoustic Calibration EQ Professional

1 Select 'EQ Professional', then press ENTER.

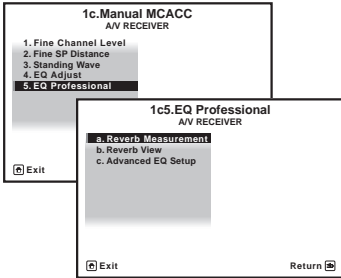

2 Select an option and press ENTER.

- **Reverb Measurement** – Use this to measure the reverb characteristics of your room.
- **Reverb View** – You can check the reverb measurements made for specified frequency ranges in each channel.¹
- **Advanced EQ Setup** – Use this to select the time period that will be used for frequency adjustment and calibration, based on the reverb measurement of your listening area. Note that customizing system calibration using this setup will alter the settings you made in *Automatically setting up for surround sound (Auto MCACC)* on page 37 or *Automatic MCACC (Expert)* on page 78 and is not necessary if you're satisfied with these settings.

3 If you selected 'Reverb Measurement', select EQ ON or OFF, and then START.

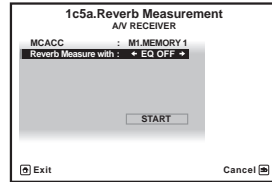

The following options determine how the reverb characteristics of your listening area are displayed in **Reverb View**:

- **EQ OFF** – You will see the reverb characteristics of your listening area *without* the equalization performed by this receiver (before calibration).
- **EQ ON** – You will see the reverb characteristics of your listening area *with* the equalization performed by this receiver (after calibration).² Note that the EQ response may not appear entirely flat due to adjustments necessary for your listening area.³

When the reverb measurement is finished, you can select **Reverb View** to see the results on-screen. See *Professional Calibration EQ graphical output* on page 107 for troubleshooting information.

Note

- 1 If the **Reverb View** procedure is performed after the *Automatically setting up for surround sound (Auto MCACC)* on page 37 or **Reverb Measurement** operation, depending on the standing wave control setting, differences may appear on the reverb graph. With the Auto MCACC function, the reverberations are measured with the standing waves controlled, so the reverb characteristics graph shows the characteristics with the effect of the standing waves eliminated. By contrast, the **Reverb Measurement** function measures the reverberations without controlling the standing waves, so the graph indicates the reverb characteristics including the effect of the standing waves. If you wish to check the reverb characteristics of the room itself (with the standing waves as such), we recommend using the **Reverb Measurement** function.
- 2 The calibration corresponding to the currently selected MCACC preset will be used when **EQ ON** is selected. To use another MCACC preset, exit the **HOME MENU** and press **MCACC** to select it before pressing **HOME MENU**.
- 3 After auto calibration with **EQ Type : SYMMETRY (Full Auto MCACC, etc.)**, the graph for the inferred reverb characteristics can be displayed by selecting **Reverb View**. To display the actually measured reverb characteristics after EQ calibration, measure with **EQ ON**.

4 If you selected 'Reverb View', you can check the reverb characteristics for each channel. Press RETURN when you're done.

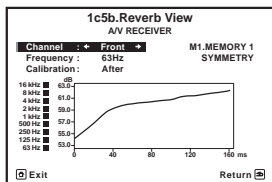

The reverb characteristics are displayed when the **Full Auto MCACC** or **Reverb Measurement** measurements are conducted.¹

Use \leftarrow/\rightarrow to select the channel, frequency and calibration setting you want to check. Use \uparrow/\downarrow to go back and forth between the three. The reverb characteristics graph before and after EQ calibration can be displayed by selecting **Calibration : Before / After**.² Note that the markers on the vertical axis indicate decibels in 2 dB steps.

5 If 'Advanced EQ Setup' is selected, select the MCACC memory to be stored, then enter the desired time setting for calibration, and then select **START**.

Based on the reverb measurement above, you can choose the time period that will be used for the final frequency adjustment and calibration. Even though you can make this setting without reverb measurement, it is best to use the measurement results as a reference for your

time setting. For an optimal system calibration based on the direct sound coming from the speakers, we recommend using the **30-50ms** setting.

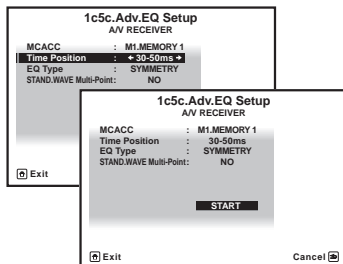

Use \leftarrow/\rightarrow to select the setting. Use \uparrow/\downarrow to switch between them.

Select the setting from the following time periods (in milliseconds): **0-20ms, 10-30ms, 20-40ms, 30-50ms, 40-60ms, 50-70ms** and **60-80ms**. This setting will be applied to all channels during calibration.

When you're finished, select **START**. It will take about 2 to 4 minutes for the calibration to finish.

After the Acoustic Calibration Equalization is set, you are given the option to check the settings on-screen.

Note

- ¹ The **After** display when measurements have been made using the **Full Auto MCACC** or **Auto MCACC (ALL)** function shows the graph for the inferred reverb characteristics after **EQ Type : SYMMETRY** calibration.
- ² The reverb characteristics graph is overwritten each time the reverberations are measured. **No Data** is displayed if there is no reverb characteristic data, for example before measurements have been taken.

Checking MCACC Data

At the procedure of *Automatically setting up for surround sound (Auto MCACC)* on page 37, the procedure of *Automatic MCACC (Expert)* on page 78 or after fine-adjusting at *Manual MCACC setup* on page 82, you can check your calibrated settings using the GUI screen.

1 Press [RECEIVER], then press HOME MENU.

A Graphical User Interface (GUI) screen appears on your TV. Use **↑/↓/←/→** and **ENTER** to navigate through the screens and select menu items. Press **RETURN** to confirm and exit the current menu.

2 Select 'MCACC Data Check' from the HOME MENU.

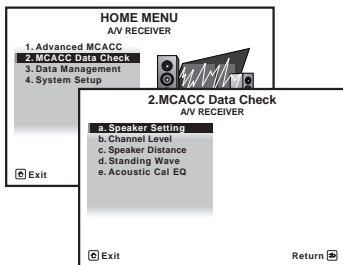

3 Select the setting you want to check.

- **Speaker Setting** – Used to check the settings of the speaker systems. See *Speaker Setting* below for more on this.
- **Channel Level** – Used to check the output level of the different speakers. See *Channel Level* below for more on this.
- **Speaker Distance** – Used to check the distance to the different speakers. See *Speaker Distance* on page 90 for more on this.
- **Standing Wave** – Used to check the standing wave control filter settings. See *Standing Wave* on page 90 for more on this.

- **Acoustic Cal EQ** – Used to check the calibration values of the listening environment's frequency response. See *Acoustic Cal EQ* on page 90 for more on this.

4 Press RETURN to go back to MCACC Data Check menu, repeating steps 2 and 3 to check other settings.

5 When you're finished, press RETURN. You will return to the **HOME MENU**.

Speaker Setting

Use this to display the speaker size and number of speakers. See *Speaker Setting* on page 95 for more on this.

1 Select 'Speaker Setting' from the MCACC Data Check menu.

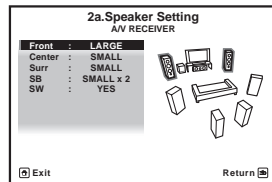

2 Select the channel you want to check.

Use **↑/↓** to select the channel. The corresponding channel on the layout diagram is highlighted.

Channel Level

Use this to display the level of the various channels. See *Channel Level* on page 96 for more on this.

1 Select 'Channel Level' from the MCACC Data Check menu.

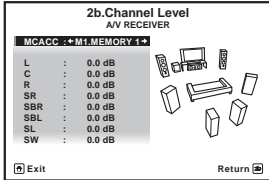

2 When 'MCACC' is highlighted, use ←/→ to select the MCACC preset you want to check.

The level of the various channels set at the selected MCACC preset is displayed. '---' is displayed for channels that are not connected.

Speaker Distance

Use this to display the distance from the different channels to the listening position. See *Speaker Distance* on page 97 for more on this.

1 Select 'Speaker Distance' from the MCACC Data Check menu.

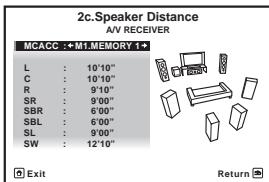

2 When 'MCACC' is highlighted, use ←/→ to select the MCACC preset you want to check.

The distance from the various channels set at the selected MCACC preset is displayed. '---' is displayed for channels that are not connected.

Standing Wave

Use this to display the standing wave related adjustment values for the various MCACC memories. See *Standing Wave* on page 85 for more on this.

1 Select 'Standing Wave' from the MCACC Data Check menu.

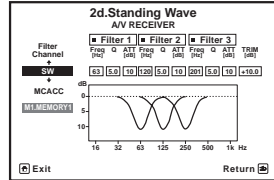

2 When 'Filter Channel' is highlighted, use ↑/↓ to select the channel for which you want to check standing wave control.

The standing wave related calibration value for the selected channel stored at the selected MCACC preset and its graph are displayed.

3 Press ← to highlight 'MCACC', then use ↑/↓ to select the MCACC preset you want to check.

Acoustic Cal EQ

Use this to display the calibration values for the frequency response of the various channels set in the different MCACC presets. See *Acoustic Calibration EQ Adjust* on page 85 for more on this.

1 Select 'Acoustic Cal EQ' from the MCACC Data Check menu.

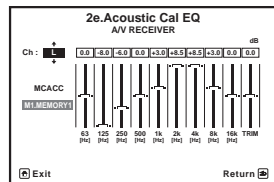

2 When 'Ch' is highlighted, use ↑/↓ to select the channel.

The calibration value for the frequency response of the selected channel stored at the selected MCACC preset and its graph are displayed.

3 Press ← to highlight 'MCACC', then use ↑/↓ to select the MCACC preset you want to check.

Data Management

This system allows you to store up to six MCACC presets, allowing you to calibrate your system for different listening positions (or frequency adjustments for the same listening position).¹ This is useful for alternate settings to match the kind of source you're listening to and where you're sitting (for example, watching movies from a sofa, or playing a video game close to the TV).

From this menu you can copy from one preset to another, name presets for easier identification and clear any ones you don't need.

1 Press **RECEIVER**, then press **HOME MENU**.

A Graphical User Interface (GUI) screen appears on your TV. Use **↑/↓/←/→** and **ENTER** to navigate through the screens and select menu items. Press **RETURN** to confirm and exit the current menu.

2 Select 'Data Management' from the **HOME MENU**.

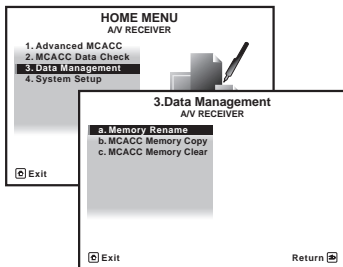

3 Select the setting you want to adjust.

- **Memory Rename** – Name your MCACC presets for easy identification (see *Renaming MCACC presets* below).
- **MCACC Memory Copy** – Copy settings from one MCACC preset to another (see *Copying MCACC preset data* on page 92).

- **MCACC Memory Clear** – Clear any MCACC presets that you don't want (see *Clearing MCACC presets* on page 92).

Renaming MCACC presets

If you have several different MCACC presets that you're using, you may want to rename them for easier identification.

1 Select 'Memory Rename' from the **Data Management** setup menu.

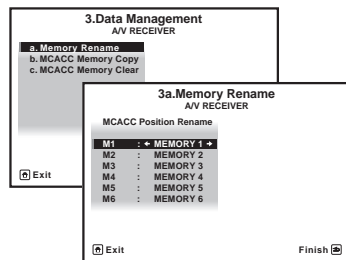

2 Select the MCACC preset you want to rename, then select an appropriate preset name.

Use **↑/↓** to select the preset, then **←/→** to select a preset name.

3 Repeat for as many MCACC presets as necessary, then press **RETURN** when you're finished.

You will return to the **Data Management** setup menu.

Note

¹ This can be done in *Automatically setting up for surround sound (Auto MCACC)* on page 37 or *Automatic MCACC (Expert)* on page 78, either of which you should have already completed.

Copying MCACC preset data

If you want to manually adjust the Acoustic Calibration EQ (see *Manual MCACC setup* on page 82), we recommend copying your current settings¹ to an unused MCACC preset. Instead of just a flat EQ curve, this will give you a reference point from which to start.

1 Select 'MCACC Memory Copy' from the Data Management setup menu.

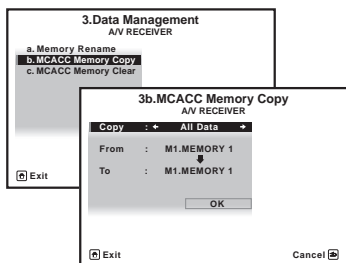

2 Select the setting you want to copy.

- **All Data** – Copies all the settings of the selected MCACC preset memory.
- **Level & Distance** – Copies only the channel level and speaker distance settings of the selected MCACC preset memory.

3 Select the MCACC preset you'll be copying the settings 'From', then specify where you want to copy them ('To').

Make sure you don't overwrite an MCACC preset you're currently using (this can't be undone).

4 Select 'OK' to confirm and copy the settings.

When **MCACC Memory Copy?** is displayed, select **YES**. If **NO** is selected, the memory is not copied.

Completed! shows in the GUI screen to confirm the MCACC preset has been copied, then you automatically return to the **Data Management** setup menu.

Note

¹ The settings made in *Automatically setting up for surround sound (Auto MCACC)* on page 37 or *Automatic MCACC (Expert)* on page 78.

Clearing MCACC presets

If you are no longer using one of the MCACC presets stored in memory, you can choose to clear the calibration settings of that preset.

1 Select 'MCACC Memory Clear' from the Data Management setup menu.

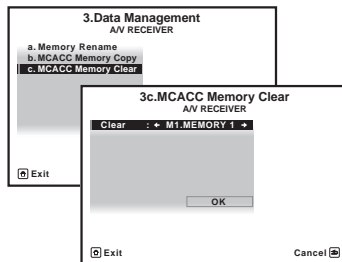

2 Select the MCACC preset you want to clear.

Make sure you don't clear an MCACC preset you're currently using (this can't be undone).

3 Select 'OK' to confirm and clear the preset.

When **MCACC Memory Clear?** is displayed, select **YES**. If **NO** is selected, the memory is not cleared.

Completed! shows in the GUI screen to confirm the MCACC preset has been cleared, then you automatically return to the **Data Management** setup menu.

Chapter 11:

The system and the other setup

Making receiver settings from the System Setup menu

The following section describes how to change the speaker-related settings manually and make various other settings (input selection, OSD language selection, etc.).

1 Switch on the receiver and your TV.

Use the **RECEIVER** button to switch on.¹

- If headphones are connected to the receiver, disconnect them.

2 Press **RECEIVER**, then press **HOME MENU**.²

A Graphical User Interface (GUI) screen appears on your TV. Use **↑/↓/←/→** and **ENTER** to navigate through the screens and select menu items. Press **RETURN** to confirm and exit the current menu.

- Press **HOME MENU** at any time to exit the **HOME MENU**.

3 Select 'System Setup' from the HOME MENU, then press ENTER.

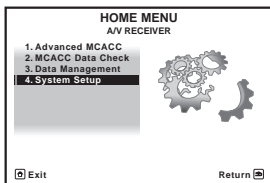

4 Select the setting you want to adjust.

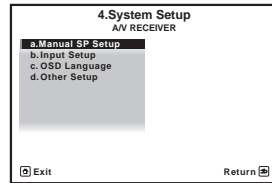

- **Manual SP Setup** – Sets the type of connection used for surround back terminals and the size, number distance and overall balance of the connected speakers (see *Manual speaker setup* on page 94).
- **Input Setup** – Specifies what you've connected to the digital, HDMI and component video inputs (see *The Input Setup menu* on page 39).
- **OSD Language** – The GUI screen's display language can be changed (see *Changing the OSD display language (OSD Language)* on page 36).
- **Other Setup** – Makes customized settings to reflect how you are using the receiver (see *The Other Setup menu* on page 98).

Note

- 1 Make sure not to switch off the power when using the System Setup menu.
- 2 You can't use the **HOME MENU** when either the iPod/USB or SIRIUS Radio input function is selected or the headphones are connected. When you set **ZONE 2** to **ON** (page 69), you can't use the **HOME MENU**.

Manual speaker setup

This receiver allows you to make detailed settings to optimize the surround sound performance. You only need to make these settings once (unless you change the placement of your current speaker system or add new speakers).

These settings are designed to customize your system, but if you're satisfied with the settings made in *Automatically setting up for surround sound (Auto MCACC)* on page 37, it isn't necessary to make all of these settings.

CAUTION

- The test tones used in the **Manual SP Setup** are output at high volume.

1 Select 'Manual SP Setup', then press ENTER.

See *Making receiver settings from the System Setup menu* on page 93 if you're not already at this screen.

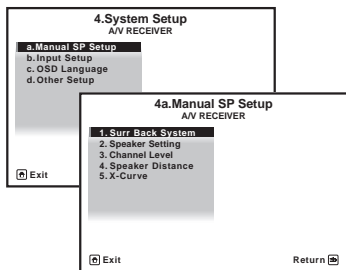

2 Select the setting you want to adjust.

If you are doing this for the first time, you may want to adjust these settings in order:

- Surr Back System** – Specifies how you are using your surround back speakers (see below).
- Speaker Setting** – Specifies the size and number of speakers you've connected (page 95).

- Channel Level** – Adjusts the overall balance of your speaker system (page 96).
- Speaker Distance** – Specifies the distance of your speakers from the listening position (page 97).
- X-Curve** – Adjusts the tonal balance of your speaker system for movie soundtracks (page 98).

3 Make the adjustments necessary for each setting, pressing RETURN to confirm after each screen.

Surround back speaker setting

- Default setting: **Normal**

There are several ways you can use the surround back speaker channels with this system. In addition to a normal home theater setup where they are used for the surround back speakers, they can be used for bi-amping the front speakers or as an independent speaker system in another room.

1 Select 'Surr Back System' from the Manual SP Setup menu.

See *Making receiver settings from the System Setup menu* on page 93 if you're not already at this screen.

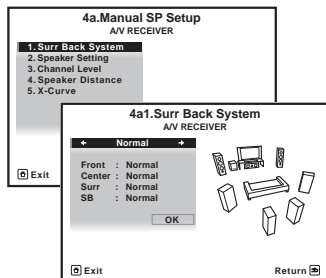

2 Select the surround back speaker setting.

- **Normal** – Select for normal home theater use with surround back speakers in your main (speaker system A) setup.
- **Speaker B** – Select to use the (surround back) B speaker terminals to listen to stereo playback in another room (see *Switching the speaker system* on page 69).
- **Front Bi-Amp** – Select this setting if you're bi-amping your front speakers (see *Bi-amping your speakers* on page 20).
- **ZONE 2** – Select to use the (surround back) B speaker terminals for an independent system in another zone (see *Using the MULTI-ZONE controls* on page 69).

3 When 'Setting Change?' is displayed, select Yes.

If **No** is selected, the setting is not changed. You will return to the **Manual SP Setup** menu.

Speaker Setting

Use this setting to specify your speaker configuration (size, number of speakers and crossover frequency)¹. It is a good idea to make sure that the settings made in *Automatically setting up for surround sound (Auto MCACC)* on page 37 are correct. Note that this setting applies to all MCACC presets, and cannot be set independently.

1 Select 'Speaker Setting' from the Manual SP Setup menu.

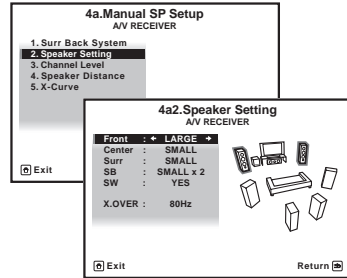

2 Choose the set of speakers that you want to set, then select a speaker size.

Use **←/→** to select the size (and number) of each of the following speakers:²

- **Front** – Select **LARGE** if your front speakers reproduce bass frequencies effectively, or if you didn't connect a subwoofer. Select **SMALL** to send the bass frequencies to the subwoofer.
- **Center** – Select **LARGE** if your center speaker reproduces bass frequencies effectively, or select **SMALL** to send bass frequencies to the other speakers or subwoofer. If you didn't connect a center speaker, choose **NO** (the center channel is sent to the front speakers).
- **Surr** – Select **LARGE** if your surround speakers reproduce bass frequencies effectively. Select **SMALL** to send bass frequencies to the other speakers or subwoofer. If you didn't connect surround speakers choose **NO** (the sound of the surround channels is sent to the front speakers or a subwoofer).

Note

¹ If you're using a THX speaker setup, set all speakers to **SMALL**.

² If you select **SMALL** for the front speakers the subwoofer will automatically be fixed to **YES**. Also, the center, surround and surround back speakers can't be set to **LARGE** if the front speakers are set to **SMALL**. In this case, all bass frequencies are sent to the subwoofer.

- **SB** – Select the number of surround back speakers you have (one, two or none).¹ Select **LARGE_{x2}** or **LARGE_{x1}** if your surround back speakers reproduce bass frequencies effectively. Select **SMALL_{x2}** or **SMALL_{x1}** to send bass frequencies to the other speakers or subwoofer. If you didn't connect surround back speakers choose **NO**.
- **SW** – LFE signals and bass frequencies of channels set to **SMALL** are output from the subwoofer when **YES** is selected. Choose the **PLUS** setting if you want the subwoofer to output bass sound continuously or you want deeper bass (the bass frequencies that would normally come out the front and center speakers are also routed to the subwoofer).² If you did not connect a subwoofer choose **NO** (the bass frequencies are output from other speakers).

3 Select 'X. OVER' and set the crossover frequency.³

Frequencies below this point will be sent to the subwoofer (or **LARGE** speakers).

4 When you're finished, press RETURN.

You will return to the **Manual SP Setup** menu.

Channel Level

Using the channel level settings, you can adjust the overall balance of your speaker system, an important factor when setting up a home theater system.

1 Select 'Channel Level' from the Manual SP Setup menu.

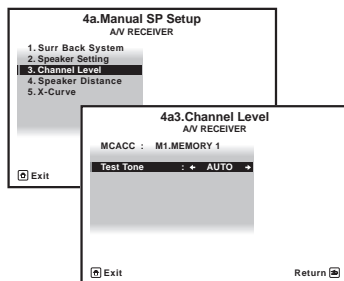

2 Select a setup option.

- **MANUAL** – Move the test tone manually from speaker to speaker and adjust individual channel levels.
- **AUTO** – Adjust channel levels as the test tone moves from speaker to speaker automatically.

Note

- 1 If you selected **Speaker B, ZONE 2** or **Front Bi-Amp** (in *Surround back speaker setting* on page 94) you can't adjust the surround back settings.
 - If the surround speakers are set to **NO**, the surround back speakers will automatically be set to **NO**.
 - If you select one surround back speaker only, make sure that speaker is hooked up to the left surround back terminal.
- 2 If you have a subwoofer and like lots of bass, it may seem logical to select **LARGE** for your front speakers and **PLUS** for the subwoofer. This may not, however, yield the best bass results. Depending on the speaker placement of your room you may actually experience a decrease in the amount of bass due low frequency cancellations. In this case, try changing the position or direction of speakers. If you can't get good results, listen to the bass response with it set to **PLUS** and **YES** or the front speakers set to **LARGE** and **SMALL** alternatively and let your ears judge which sounds best. If you're having problems, the easiest option is to route all the bass sounds to the subwoofer by selecting **SMALL** for the front speakers.
- 3 This setting decides the cutoff between bass sounds playing back from the speakers selected as **LARGE**, or the subwoofer, and bass sounds playing back from those selected as **SMALL**. It also decides where the cutoff will be for bass sounds in the LFE channel.
 - If you're using a THX speaker setup, confirm that the crossover frequency is set to **80Hz**.

3 Confirm your selected setup option.

The test tones will start after you press **ENTER**.

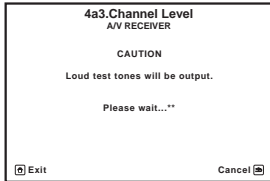

4 Adjust the level of each channel using ←/→.

If you selected **MANUAL**, use ↑/↓ to switch speakers. The **AUTO** setup will output test tones in the order shown on-screen:

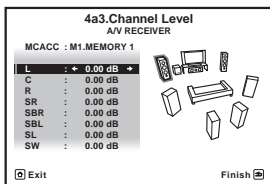

Adjust the level of each speaker as the test tone is emitted.¹

5 When you're finished, press RETURN.

You will return to the **Manual SP Setup** menu.



Tip

- You can change the channel levels at any time by press **RECEIVER**, then press **CH LEVEL**, and then using ←/→ on the remote control.

Speaker Distance

For good sound depth and separation from your system, you need to specify the distance of your speakers from the listening position. The receiver can then add the proper delay needed for effective surround sound.

1 Select 'Speaker Distance' from the Manual SP Setup menu.

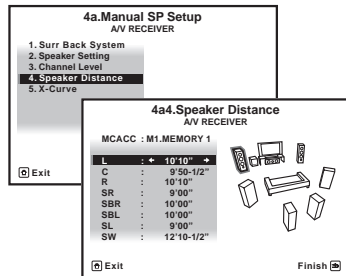

2 Adjust the distance of each speaker using ←/→.

You can adjust the distance of each speaker in 1/2 inch increments.

3 When you're finished, press RETURN.

You will return to the **Manual SP Setup** menu.



Tip

- For best surround sound, make sure the surround back speakers are the same distance from the listening position.

Note

- If you are using a Sound Pressure Level (SPL) meter, take the readings from your main listening position and adjust the level of each speaker to 75 dB SPL (C-weighting/slow reading).
 - The subwoofer test tone is output at low volumes. You may need to adjust the level after testing with an actual soundtrack.

X-Curve

Most soundtracks mixed for cinema sound too bright when played back in large rooms. The X-Curve setting acts as a kind of re-equalization for home theater listening, and restores proper tonal balance of movie soundtracks.

1 Select 'X-Curve' from the Manual SP Setup menu.

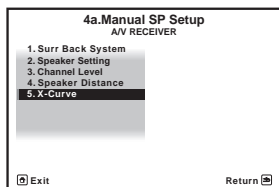

2 Choose the X-Curve setting you want.

Use \leftarrow/\rightarrow to adjust the setting. The X-Curve is expressed as a downwards slope in decibels per octave, starting at 2 kHz. The sound becomes less bright as the slope increases (to a maximum of **-3.0dB/oct**). Use the following guidelines to set the X-Curve according to your room size:

Room size (ft ²)	≤400	≤550	≤650	≤800	≤2200	≤12000
X-Curve (dB/oct)	-0.5	-1.0	-1.5	-2.0	-2.5	-3.0

- If you select **OFF**, the frequency curve will be flat and the X-Curve has no effect.

3 When you're finished, press RETURN.

The Other Setup menu

The **Other Setup** menu is where you can make customized settings to reflect how you are using the receiver.

1 Press **RECEIVER** on the remote control, then press HOME MENU.

A Graphical User Interface (GUI) screen appears on your TV. Use $\uparrow/\downarrow/\leftarrow/\rightarrow$ and **ENTER** to navigate through the screens and select menu items. Press **RETURN** to confirm and exit the current menu.

2 Select 'System Setup' from the HOME MENU.

3 Select 'Other Setup', then press ENTER.

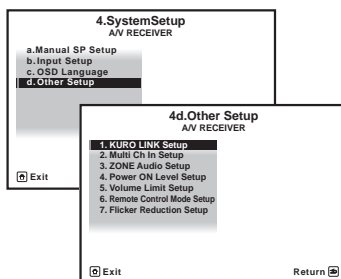

4 Select the setting you want to adjust.

If you are doing this for the first time, you may want to adjust these settings in order:

- **KURO LINK Setup** – Synchronizes this receiver with your Pioneer component supporting KURO LINK (see *KURO LINK Setup* on page 62).
- **Multi Ch In Setup** – Specifies the optional settings for a multi-channel input (page 99).
- **ZONE Audio Setup** – Specifies the volume setting for a MULTI-ZONE setup (page 99).
- **Power ON Level Setup** – Specifies the volume level set when the power is turned on (page 100).
- **Volume Limit Setup** – Limits the maximum volume (page 100).

- **Remote Control Mode Setup** – Sets this receiver's remote control mode (page 101).
- **Flicker Reduction** – Adjusts the way the GUI screen looks (page 101).

5 Make the adjustments necessary for each setting, pressing RETURN to confirm after each screen.

Multi Channel Input Setup

You can adjust the level of the subwoofer for a multi-channel input. Also, when the multi-channel input is selected as an input function, you can display the video images of other input functions. In the Multi Channel Input Setup, you can assign a video input to the multi-channel input.

1 Select 'Multi Ch In Setup' from the Other Setup menu.

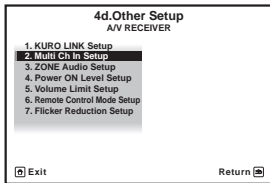

2 Select the 'SW Input Gain' setting you want.

- **0dB** – Outputs sound of the subwoofer at the level originally recorded on the source.
- **+10dB** – Outputs sound of the subwoofer at the level increased by 10 dB.

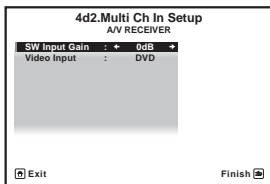

3 Select the 'Video Input' setting you want.

When the multi-channel input is selected as an input function, you can display the video images of other input functions. The video input can be selected from the following: **DVD, TV/SAT, DVR, VIDEO, OFF.**

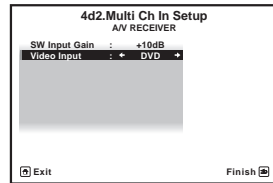

4 When you're finished, press RETURN.

You will return to the **Other Setup** menu.

ZONE Audio Setup

If you've made MULTI-ZONE connections (see *Using the MULTI-ZONE controls* on page 69), you may need to specify your volume setting.

1 Select 'ZONE Audio Setup' from the Other Setup menu.

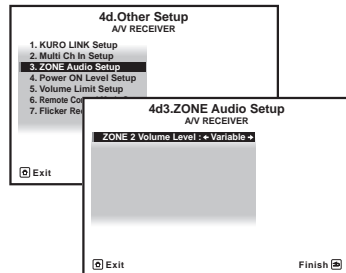

2 Select the volume level setting of ZONE 2.¹

- **Variable** – Use this setting if you've connected a power amplifier in the sub room (this receiver is simply being used as a pre-amp) and you will be using this receiver's controls to adjust the volume.

Note

¹ If you selected **ZONE 2** in the *Surround back speaker setting* on page 94, you won't be able to change the volume level.

- **Fixed** – Use this setting if you've connected a fully integrated amplifier (such as another Pioneer VSX receiver) in the sub room and want to use that receiver's volume controls.

With the **Fixed** setting, the source is sent from this receiver at maximum volume, so make sure the volume is quite low in the sub zone at first, and then experiment to find the correct level.

3 When you're finished, press RETURN.

You will return to the **Other Setup** menu.

Power ON Level Setup

The volume can be set so that it is always set to the same level when the receiver's power is turned on.

1 Select 'Power ON Level Setup' from the Other Setup menu.

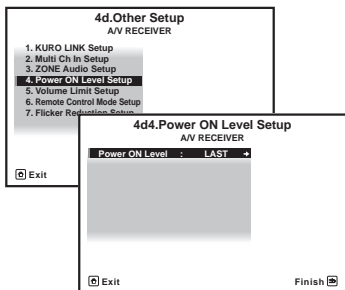

2 Select the Power ON Level setting you want.

- **LAST** – When the power is turned on, the volume is set to the same level as when the power was last turned off.
- **---** – When the power is turned on, the volume is set to minimum level.
- **-80.0dB to +12.0dB** – Specify the volume to be set when the power is turned, in steps of 0.5 dB.

It is not possible to set a volume level greater than the value specified at Volume Limit Setup.

3 When you're finished, press RETURN.

You will return to the **Other Setup** menu.

Volume Limit Setup

Use this function to limit the maximum volume. The volume cannot be increased above the level set here, even by operating **MASTER VOLUME** button (or the dial on the front panel).

1 Select 'Volume Limit Setup' from the Other Setup menu.

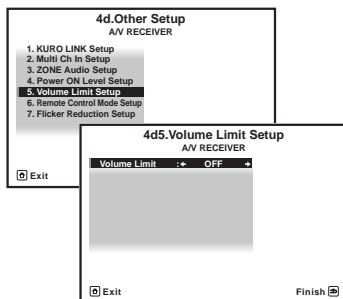

2 Select the Volume Limit setting you want.

- **OFF** – The maximum volume is not limited.
- **-20.0dB/-10.0dB/0.0dB** – The maximum volume is limited to the value set here.

3 When you're finished, press RETURN.

You will return to the **Other Setup** menu.

Remote Control Mode Setup

- Default setting: 1

This sets this receiver's remote control mode to prevent erroneous operation when multiple units of the receiver are being used.¹

1 Select 'Remote Control Mode Setup' from the Other Setup menu.

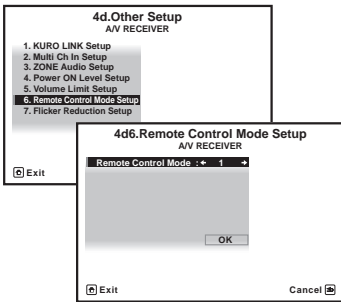

2 Select the Remote Control Mode setting you want.

3 Select "OK" to change the remote control mode.

4 Follow the instructions on the screen to change the remote control's setting.

See *Operating multiple receivers* on page 73.

5 When you're finished, press RETURN.

You will return to the **Other Setup** menu.

Flicker Reduction Setup

- Default setting: 4

The GUI screen's resolution can be increased. If you feel the GUI screen is hard to see, try changing this setting. Note that the resolution in this setting only affects the GUI screen; it has no influence on the video output.

1 Select 'Flicker Reduction Setup' from the Other Setup menu.

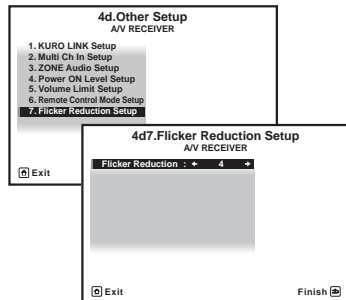

2 Select the Flicker Reduction setting you want.

3 When you're finished, press RETURN.

You will return to the **Other Setup** menu.

Note

¹ If you change this receiver's setting, also change the setting on the remote control.

Chapter 12:

Additional information

Troubleshooting

Incorrect operations are often mistaken for trouble and malfunctions. If you think that there is something wrong with this component, check the points below. Sometimes the trouble may lie in another component. Investigate the other components and electrical appliances being used. If the trouble cannot be rectified even after exercising the checks listed below, ask your nearest Pioneer authorized independent service company to carry out repair work.



Note

- If the unit does not operate normally due to external effects such as static electricity disconnect the power plug from the outlet and insert again to return to normal operating conditions.

Power

Symptom	Remedy
The power does not turn on.	<ul style="list-style-type: none"> • Make sure that the power cable is plugged in to an active power outlet. • Try disconnecting from the power outlet, then plugging back in.
Power cannot be turned off. (ZONE 2 ON is displayed.)	<ul style="list-style-type: none"> • Set the remote control's MULTI-ZONE operation selector switch to ZONE 2, then press RECEIVER to switch the Zone 2 off.
The receiver suddenly switches off or the PHASE CONTROL indicator blinks.	<ul style="list-style-type: none"> • Check that there are no loose strands of speaker wire touching the rear panel or another set of wires. If so, re-attach the speaker wires, making sure there are no stray strands. • The receiver may have a serious problem. Disconnect from the power and call a Pioneer authorized independent service company.
During loud playback the power suddenly switches off.	<ul style="list-style-type: none"> • Turn down the volume. • Lower the 63 Hz and 125 Hz equalizer levels in the <i>Manual MCACC setup</i> on page 82. • Switch on the digital safety feature. While holding down ENTER on the front panel, press STANDBY/ON to set this receiver to the standby mode. Use TUNE +/- to select D.SAFETY <OFF>, and then use PRESET +/- to select 1 or 2 (select D.SAFETY <OFF> to deactivate this feature). If the power switches off even with 2 switched on, turn down the volume. With 1 or 2 on, some features may be unavailable.
The unit does not respond when the buttons are pressed.	<ul style="list-style-type: none"> • Try switching the receiver off, then back on again. • Try disconnecting the power cable, then connect again.

Symptom	Remedy
AMP ERR blinks in the display, then the power automatically switches off. The ADVANCED MCACC blinks and the power does not turn on.	<ul style="list-style-type: none"> The receiver may have a serious problem. Do not try switching the receiver on. Contact a Pioneer authorized independent service company for help.
Power indicator flashes and power turns off.	<ul style="list-style-type: none"> There is a problem with the receiver's power unit or fan. Try turning on the power after 1 minute. If the same thing happens, the receiver is damaged. Unplug the receiver from the wall and call a Pioneer authorized independent service company. (Other symptoms may appear when the power is turned on.)
AMP OVERHEAT and the power indicator flash and the power turns off.	<ul style="list-style-type: none"> Allow the unit to cool down in a well-ventilated place before switching back on. Wait at least 1 minute, then try turning the power on again.
The Receiver suddenly power off or the blue indicator at the center of the receiver flashes.	<ul style="list-style-type: none"> The power unit is damaged. Unplug the receiver from the wall and call a Pioneer authorized independent service company.

No sound

Symptom	Remedy
No sound is output when an input function is selected. No sound output from the front speakers.	<ul style="list-style-type: none"> Check the volume, mute setting (press MUTE) and speaker setting (press SPEAKERS). Make sure the correct input function is selected. Check that the MCACC setup microphone is disconnected. Make sure the correct input signal is selected (press SIGNAL SEL). Note that when PCM is selected, you won't be able to hear any other signal format. Check that the source component is connected properly (see <i>Connecting your equipment</i> on page 14). Check that the speakers are connected properly (see <i>Connecting the speakers</i> on page 18).
No sound from the surround or center speakers.	<ul style="list-style-type: none"> Check that the Stereo listening mode or the Front Stage Surround Advance mode isn't selected; select one of the surround listening modes (see <i>Listening in surround sound</i> on page 53). Check that the surround/center speakers are not set to NO (see <i>Speaker Setting</i> on page 95). Check the channel level settings (see <i>Channel Level</i> on page 96). Check the speaker connections (see <i>Connecting the speakers</i> on page 18).
No sound from surround back speakers.	<ul style="list-style-type: none"> Check that the surround back speakers are set to LARGE or SMALL (see <i>Speaker Setting</i> on page 95). Make sure surround back channel processing is set to SBch ON (see <i>Using surround back channel processing</i> on page 56). If the source is Dolby Surround EX or DTS-ES with no flag to indicate 6.1 compatibility, then with surround back channel processing set to SBch Auto, there will be no sound from the surround back speakers. In this case, set to SBch ON (see <i>Using surround back channel processing</i> on page 56).

Symptom	Remedy
No sound from surround back speakers. (Continued)	<ul style="list-style-type: none"> • If the source does not have 6.1 playback channels, make sure that surround back channel processing is set to SBch ON and a surround mode is selected (see <i>Listening in surround sound</i> on page 53). • Check the speaker connections (see <i>Connecting the speakers</i> on page 18). • If only one surround back speaker is connected, make sure it's connected to the left channel speaker terminal.
No sound from subwoofer.	<ul style="list-style-type: none"> • Check that the subwoofer is connected properly, switched on and the volume turned up. • If your subwoofer has a sleep function, make sure it is switched off. • Make sure that the Subwoofer setting is YES or PLUS (see <i>Speaker Setting</i> on page 95). • The crossover frequency may be set too low; try setting it higher to match the characteristics of your other speakers (see <i>Speaker Setting</i> on page 95). • If there is very little low frequency information in the source material, change your speaker settings to Front: SMALL / Subwoofer: YES, or Front: LARGE / Subwoofer: PLUS (see <i>Speaker Setting</i> on page 95). • Check that the LFE channel is not set to OFF, or a very quiet setting (see <i>Setting the Audio options</i> on page 64). • Check the speaker level settings (see <i>Channel Level</i> on page 96).
No sound from one speaker.	<ul style="list-style-type: none"> • Check the speaker connection (see <i>Connecting the speakers</i> on page 18). • Check the speaker level settings (see <i>Channel Level</i> on page 96). • Check that the speaker hasn't been set to NO (see <i>Speaker Setting</i> on page 95). • The channel may not be recorded in the source. By using one of the advanced effect listening mode, you may be able to create the missing channel (see <i>Listening in surround sound</i> on page 53).
Sound is produced from analog components, but not from digital ones (DVD, LD, CD-ROM, etc.).	<ul style="list-style-type: none"> • Check that the input signal type is set to DIGITAL (see <i>Choosing the input signal</i> on page 58). • Make sure that the digital input is assigned correctly for the input jack the component is connected to (see <i>The Input Setup menu</i> on page 39). • Check the digital output settings on the source component. • If the source component has a digital volume control, make sure this is not turned down. • Make sure that the multichannel analog inputs are not selected. Select any other input function.
No sound is output or a noise is output when Dolby Digital/DTS software is played back.	<ul style="list-style-type: none"> • Check that your DVD player is compatible with Dolby Digital/DTS discs. • Check the digital output settings of your DVD player. Make sure that the DTS signal output is set to On. • If the source component has a digital volume control, make sure this is not turned down.
No sound when using the HOME MENU or STATUS menu.	<ul style="list-style-type: none"> • If the HDMI input function is selected, sound is muted until exiting either menu. • If sound is muted in the sub zone (ZONE 2), it will be restored after exiting the HOME MENU.

Other audio problems

Symptom	Remedy
Broadcast stations cannot be selected automatically, or there is considerable noise in radio broadcasts.	<p><i>For FM broadcasts</i></p> <ul style="list-style-type: none"> Fully extend the FM wire antenna, adjust the position for best reception and secure to a wall, etc. Use an outdoor antenna for better reception (see page 30). <p><i>For AM broadcasts</i></p> <ul style="list-style-type: none"> Adjust the position and direction of the AM antenna. Use an outdoor antenna for better reception (see page 30). Noise may be caused by interference from other equipment, such as a fluorescent light, motor, etc. Switch off or move the other equipment, or move the AM antenna.
A multichannel DVD source appears to be downmixed to 2 channels during playback.	<ul style="list-style-type: none"> Make sure that the multichannel analog inputs are selected (see <i>Selecting the multichannel analog inputs</i> on page 42).
Noise is output when scanning a DTS CD.	<ul style="list-style-type: none"> This is not a malfunction of the receiver. The scan function of your player alters the digital information, making it unreadable, resulting in noise being output. Lower the volume when scanning.
When playing a DTS format LD there is audible noise on the soundtrack.	<ul style="list-style-type: none"> Make sure that the input signal type is set to DIGITAL (see <i>Choosing the input signal</i> on page 58).
Can't record audio.	<ul style="list-style-type: none"> You can only make a digital recording from a digital source, and an analog recording from an analog source. For digital sources, make sure that what you're recording isn't copy protected. Check that the OUT jacks are properly connected to the recorders input jacks (see <i>Connecting other audio components</i> on page 29).
Subwoofer output is very low.	<ul style="list-style-type: none"> To route more signal to the subwoofer, set it to PLUS or set the front speakers to SMALL (see <i>Speaker Setting</i> on page 95).
Everything seems to be set up correctly, but the playback sound is odd.	<ul style="list-style-type: none"> The speakers may be out of phase. Check that the positive/negative speaker terminals on the receiver are matched with the corresponding terminals on the speakers (see <i>Connecting the speakers</i> on page 18).
The PHASE CONTROL feature doesn't seem to have an audible effect.	<ul style="list-style-type: none"> If applicable, check that the lowpass filter switch on your subwoofer is off, or the lowpass cutoff is set to the highest frequency setting. If there is a PHASE setting on your subwoofer, set it to 0° (or depending on the subwoofer, the setting where you think it has the best overall effect on the sound). Make sure the speaker distance setting is correct for all speakers (see <i>Speaker Distance</i> on page 97).
Noise or hum can be heard even when there is no sound being input.	<ul style="list-style-type: none"> Check that personal computers or other digital components connected to the same power source are not causing interference.
There seems to be a time lag between the speakers and the output of the subwoofer.	<ul style="list-style-type: none"> See <i>Automatically setting up for surround sound (Auto MCACC)</i> on page 37 to set up your system again using MCACC (this will automatically compensate for a delay in the subwoofer output).
The maximum volume available (shown in the front panel display) is lower than the +12dB maximum.	<ul style="list-style-type: none"> Check that the Volume Limit is set to OFF (see <i>Volume Limit Setup</i> on page 100).

Video

Symptom	Remedy
No image is output when an input is selected.	<ul style="list-style-type: none"> • Check the video connections of the source component (see page 28). • For HDMI, or when digital video conversion is set to OFF and a TV and another component are connected with different cords (in <i>Setting the Video options</i> on page 67), you must connect your TV to this receiver using the same type of video cable as you used to connect your video component. • Make sure the input assignment is correct for components connected using component video or HDMI cables (see <i>The Input Setup menu</i> on page 39). • Check the video output settings of the source component. • Check that the video input you selected on your TV is correct. • Some components (such as video game units) have resolutions that may not be converted. If adjusting this receiver's Resolution setting (in <i>Setting the Video options</i> on page 67) and/or the resolution settings on your component or display doesn't work, try switching Digital Video Conversion (in <i>Setting the Video options</i> on page 67) OFF.
Can't record video.	<ul style="list-style-type: none"> • Check that the source is not copy-protected. • The video converter is not available when making recordings. Check that the same type of video cable is used for connecting both the recorder and the video source (the one you want to record) to this receiver.
Noisy, intermittent, or distorted picture.	<ul style="list-style-type: none"> • Sometimes a video deck may output a noisy video signal (during scanning, for example), or the video quality may just be poor (with some video game units, for example). The picture quality may also depend on the settings, etc. of your display device. Switch off the video converter and reconnect the source and display device using the same type of connection (component or composite), then start playback again.

Settings

Symptom	Remedy
The Auto MCACC Setup continually shows an error.	<ul style="list-style-type: none"> • The ambient noise level may be too high. Keep the noise level in the room as low as possible (see also <i>Problems when using the Auto MCACC Setup</i> on page 39). If the noise level cannot be kept low enough, you will have to set up the surround sound manually (page 94). • When using only one surround back speaker, connect it to the SURROUND BACK L (Single) terminals. • To use a 5.1-channel speaker set, use the surround speakers for the surround channel, not the surround back channel. • Make sure there are no obstacles between the speakers and the microphone. • If Reverse Phase is displayed, try the following: <ul style="list-style-type: none"> – The speaker's wiring (+ and –) may be inverted. Check the speaker connections. – Depending on the type of speakers and their installation conditions, Reverse Phase may be displayed even if the speakers are properly connected. If this happens, select GO NEXT and continue. – If the speaker is not pointed to the microphone (listening position) or when using speakers that affect the phase (dipole speakers, reflective speakers, etc.), it may not be possible to properly identify the polarity.

Symptom	Remedy
After using the Auto MCACC Setup, the speaker size setting is incorrect.	<ul style="list-style-type: none"> • There may have been some low frequency noise in the room from an air-conditioner, motor, etc. Switch off all other appliances in the room and use Auto MCACC Setup again. • Depending on a number of factors (room size, speaker placement, etc.) this may occur in some cases. Change the speaker setting manually in <i>Speaker Setting</i> on page 95, and use the ALL (Keep SP System) option for the Auto MCACC menu in <i>Automatic MCACC (Expert)</i> on page 78 if this is a recurring problem.
Can't adjust the Fine Speaker Distance setting (page 83) properly.	<ul style="list-style-type: none"> • Check that the speakers are all in phase (make sure the positive (+) and negative (-) terminals are matched up properly).
The display shows KEY LOCK ON when you try to make settings.	<ul style="list-style-type: none"> • With the receiver in standby, press ⏻ STANDBY/ON while holding down SPEAKERS to disable the key lock.
Most recent settings have been erased.	<ul style="list-style-type: none"> • The power cord was disconnected from the wall while adjusting this setting.

Professional Calibration EQ graphical output

Symptom	Remedy
The EQ response displayed in the graphical output following calibration does not appear entirely flat.	<ul style="list-style-type: none"> • There are cases where the graph does not appear flat (even when selecting ALL CH ADJ in the Auto MCACC Setup) due to adjustments made to compensate for room characteristics to achieve optimal sound. • Areas of the graph may appear identical (before and after) when there is little or no adjustment needed. • The graph may appear to have shifted vertically when comparing before and after measurements.
EQ adjustments made using the <i>Manual MCACC setup</i> on page 82 do not appear to change the graphical output.	<ul style="list-style-type: none"> • Despite level adjustments being made, the filters used for analysis may not display these adjustments in the graphical output. However, these adjustments are taken into account by the filters dedicated to overall system calibration.
Lower frequency response curves do not seem to have been calibrated for SMALL speakers.	<ul style="list-style-type: none"> • Low frequencies used in bass management (the subwoofer channel) will not change for speakers that have been specified as SMALL in the configuration, or do not output these frequencies. • Calibration is performed, but due to your speakers' low frequency limitations, no measurable sound is output for display.

Display

Symptom	Remedy
The display is dark or off.	<ul style="list-style-type: none"> Press DIMMER repeatedly to select a different brightness.
After making an adjustment the display goes off.	<ul style="list-style-type: none"> Press DIMMER repeatedly to select a different brightness.
You can't get DIGITAL to display when using SIGNAL SEL .	<ul style="list-style-type: none"> Check the digital connections and make sure that the digital inputs are assigned correctly (see <i>The Input Setup menu</i> on page 39). If the multichannel analog inputs are selected, select a different input function.
DD DIGITAL or DTS does not light when playing Dolby/DTS software.	<ul style="list-style-type: none"> These indicators does not light if playback is paused. Check the playback (especially the digital output) settings of the source component.
When playing Dolby Digital or DTS sources, the receiver's format indicators do not light.	<ul style="list-style-type: none"> Check that the player is connected using a digital connection. Make sure that the receiver is set to AUTO or DIGITAL (see <i>Choosing the input signal</i> on page 58). Check that the player isn't set up so that Dolby Digital and DTS sources are converted to PCM. Ensure that if there are several audio tracks on the disc, the Dolby Digital or DTS is selected.
When playing certain discs, none of the receiver's format indicators light.	<ul style="list-style-type: none"> The disc may not contain 5.1/6.1 channel material. Check the disc packaging for more on what audio tracks are recorded on the disc.
When playing a disc with the listening mode set to Auto Surround or ALC, DD PL II or Neo:6 appear on the receiver.	<ul style="list-style-type: none"> Make sure that the receiver is set to AUTO or DIGITAL (see <i>Choosing the input signal</i> on page 58). If a two channel soundtrack is currently playing (including Dolby Surround encoded), then this is not a malfunction. Check the disc packaging for details about the audio tracks available.
During playback of a Surround EX or DTS-ES source on the SBch AUTO setting, EX or ES does not appear, or the signal is not properly processed.	<ul style="list-style-type: none"> The source may be Dolby Surround EX/DTS-ES software, but it has no flag to indicate it is 6.1 compatible. Set to SBch ON (see <i>Using surround back channel processing</i> on page 56), then switch to the Standard EX listening mode (see <i>Listening in surround sound</i> on page 53).
During playback of DVD-Audio, the display shows PCM .	<ul style="list-style-type: none"> This will occur when playing DVD-Audio material over the HDMI connection. This is not a malfunction.
The power turns off automatically and some indicator flashes, or some indicator flashes and the power does not turn on.	<ul style="list-style-type: none"> See the Power section (page 102).

Remote control

Symptom	Remedy
Cannot be remote controlled.	<ul style="list-style-type: none"> • Set a 5-digit preset code corresponding to the receiver to be operated in the remote control (see <i>Operating multiple receivers</i> on page 73). • Check whether the receiver's remote control mode is properly set (see <i>Remote Control Mode Setup</i> on page 101). • Try replacing the batteries in the remote control (see <i>Loading the batteries</i> on page 7). • Be sure to operate within 7 m (23 feet) and a 30° angle of the remote sensor on the front panel (see <i>Operating range of remote control unit</i> on page 13). • Check that there are no obstacles between the receiver and the remote control. • Make sure that there is no fluorescent or other strong light shining on to the remote sensor. • Check the connections of the CONTROL IN jack (see <i>Operating other Pioneer components with this unit's sensor</i> on page 32).
Other components can't be operated with the system remote.	<ul style="list-style-type: none"> • If the battery ran down, the preset codes may have been cleared. Re-enter the preset codes. • The preset code may be incorrect. Redo the procedure for entering preset codes.

HDMI

Symptom	Remedy
The HDMI indicator blinks continuously.	<ul style="list-style-type: none"> • Check all the points below.
No picture or sound.	<ul style="list-style-type: none"> • This receiver is HDCP-compatible. Check that the components you are connecting are also HDCP-compatible. If they are not, please connect them using the component or composite video jacks. • Depending on the connected source component, it's possible that it will not work with this receiver (even if it is HDCP-compatible). In this case, connect using the component or composite video jacks between source and receiver. • If the problem still persists when connecting your HDMI component directly to your monitor, please consult the component or monitor manual or contact the manufacturer for support. • If video images do not appear on your TV or flat panel TV, try adjusting the resolution, DeepColor or other setting for your component. • If 'NOT SUPPORT' appears in the receiver's display, try adjusting the resolution, DeepColor or other setting for your component. • While analog video signals are being output over HDMI, use a separate connection for audio output. • When this receiver reproduces MULTI CH IN audio sources with the HDMI setting set to THROUGH, you cannot hear audio output from all channels. In this case, make a digital or analog audio connection. • To output signals in DeepColor, use an HDMI cable (High Speed HDMI™ Cable) to connect this receiver to a component or TV with the DeepColor feature.
No picture.	<ul style="list-style-type: none"> • Try changing the Resolution setting (in <i>Setting the Video options</i> on page 67).

Symptom	Remedy
No sound, or sound suddenly ceases.	<ul style="list-style-type: none"> • Check that the HDMI AV setting is set to AMP/THROUGH. • If the component is a DVI device, use a separate connection for the audio. • If analog video is being output over HDMI, please use a separate connection for the audio. • Check the audio output settings of the source component.
Noisy or distorted picture.	<ul style="list-style-type: none"> • Sometimes a video deck may output a noisy video signal (during scanning, for example), or the video quality may just be poor (with some video game units, for example). The picture quality may also depend on the settings, etc. of your display device. Switch off the video converter and reconnect the source and display device using the same type of connection (component or composite), then start playback again. • If the problem still persists when connecting your HDMI component directly to your monitor, please consult the component or monitor manual or contact the manufacturer for support.
HDCP ERROR shows in the display.	<ul style="list-style-type: none"> • Check whether or not the connected component is compatible with HDCP. If it is not compatible with HDCP, reconnect the source device using a different type of connection (component or composite). Some components that are compatible with HDCP still cause this message to be displayed, but so long as there is no problem with displaying video, this is not a malfunction.
Amp-linked operation not possible using KURO LINK function.	<ul style="list-style-type: none"> • Check the HDMI connections. • The cable may be damaged. • Select ON for the KURO LINK setting (see <i>KURO LINK Setup</i> on page 62). • Turn the TV's power on before turning on this receiver's power. • Set the TV side KURO LINK setting to ON.

Important information regarding the HDMI connection

There are cases where you may not be able to route HDMI signals through this receiver (this depends on the HDMI-equipped component you are connecting—check with the manufacturer for HDMI compatibility information).

If you aren't receiving HDMI signals properly through this receiver (from your component), please try one of the following configurations when connecting up.

Configuration A

Use component video cables to connect the video output of your HDMI-equipped component to the receiver's component video input. The receiver can then convert the analog component video signal to a digital HDMI signal for transmission to the display. For this configuration, use the most convenient connection (digital is recommended) for sending audio to the receiver. See the operating instructions for more on audio connections.



Note

- The picture quality will change slightly during conversion.

Configuration B

Connect your HDMI-equipped component directly to the display using an HDMI cable. Then use the most convenient connection (digital is recommended) for sending audio to the receiver. See the operating instructions for more on audio connections. Set the display volume to minimum when using this configuration.



Note

- If your display only has one HDMI terminal, you can only receive HDMI video from the connected component.

- Depending on the component, audio output may be limited to the number of channels available from the connected display unit (for example audio output is reduced to 2 channels for a monitor with stereo audio limitations).
- If you want to switch the input function, you'll have to switch functions on both the receiver and your display unit.
- Since the sound is muted on the display when using the HDMI connection, you must adjust the volume on the display every time you switch input functions.

USB interface

Symptoms	Causes	Remedies
The folders/files stored on a USB memory device are not displayed.	The folders/files are currently stored in a region other than the FAT (File Allocation Table) region.	Store the folders/files in the FAT region.
	The number of levels in a folder is more than 8.	Limit the maximum number of levels in a folder to 8 (page 45).
	There are more than 30 000 folders/files stored in a USB memory device.	Limit the maximum number of folders/files stored in a USB memory device to 30 000 (page 45).
A USB memory device is not recognized.	The audio files are copyrighted.	Copyrighted audio files stored on a USB memory device cannot be played back (page 45).
	The USB memory device does not support the mass storage class specifications.	Try using a USB memory device compatible with the mass storage class specifications. Note that there are cases where even the audio files stored on a USB memory device compatible with the mass storage class specifications are not played back on this receiver (page 45).
	A USB hub is currently being used.	Connect the USB memory device and switch on this receiver (page 35). This receiver does not support a USB hub (page 45).
	This receiver recognizes the USB memory device as a fraud.	Switch off and on again this receiver.

Symptoms	Causes	Remedies
A USB memory device is connected and displayed, but the audio files stored on the USB memory device cannot be played back.	Some formats of a USB memory device, including FAT 12, NTFS, and HFS, cannot be played back on this receiver. The file format cannot be properly played back on this receiver.	Check whether the format of your USB memory device is either FAT 16 or FAT 32. Note that the FAT 12, NTFS, and HFS formats cannot be played back on this receiver (page 45). See the list of file formats that can be played back on this receiver (page 48).

SIRIUS radio messages

Message	Cause	Action
Antenna ERROR	Antenna is not properly connected.	Check that the antenna cable is attached securely.
Check Sirius Tuner	SIRIUS Connect tuner is not properly connected.	Check that the 8 pin mini DIN cable and AC Adapter are attached securely.
Acquiring Signal	The SIRIUS signal is too weak at the current location.	n/a
Subscription Updating	Unit is updating subscription.	Wait until the encryption code has been updated.
Updating Channels	Unit is updating channels.	Wait until the encryption code has been updated.
Invalid Channel	Selected channel is not available/ does not exist.	Select another channel.
Firmware Updating	The SIRIUS Connect tuner's firmware is being updated.	Wait for updating to finish.

If the problem is not solved after the troubleshooting above, if the screen freezes unexpectedly or if the buttons on the remote control or front panel stop working completely, do the following:

- Press **⏻ STANDBY/ON** on the front panel to turn off the power, then turn the power back on.
- If the power cannot be turned off, press and hold **⏻ STANDBY/ON** on the front panel for over 10 seconds. The power will turn off. (In this case, the various settings made on the receiver may be cleared.)

Surround sound formats

Below is a brief description of the main surround sound formats you'll find on DVDs, satellite, cable and terrestrial broadcasts, and video cassettes.

Dolby

The Dolby technologies are explained below. See www.dolby.com for more detailed information.



Manufactured under license from Dolby Laboratories. Dolby and the double-D symbol are trademarks of Dolby Laboratories.

DTS

The DTS technologies are explained below. See www.dtstech.com for more detailed information.



Manufactured under license under U.S. Patent #'s: 5,451,942; 5,956,674; 5,974,380; 5,978,762; 6,226,616; 6,487,535; 7,212,872; 7,333,929; 7,392,195; 7,272,567 & other U.S. and worldwide patents issued & pending. DTS is a registered trademark and the DTS logos, Symbol, DTS-HD and DTS-HD Master Audio are trademarks of DTS, Inc. © 1996-2008 DTS, Inc. All Rights Reserved.

Windows Media Audio 9 Professional

Windows Media Audio 9 Professional (WMA9 Pro) is a discrete surround format developed by Microsoft Corporation.



Windows Media and the Windows logo are trademarks or registered trademarks of Microsoft Corporation in the United States and/or other countries.

About iPod



"Made for iPod" means that an electronic accessory has been designed to connect specifically to iPod and has been certified by the developer to meet Apple performance standards.

"Works with iPhone" means that an electronic accessory has been designed to connect specifically to iPhone and has been certified by the developer to meet Apple performance standards.

Apple is not responsible for the operation of this device or its compliance with safety and regulatory standards.

iPod is a trademark of Apple Inc., registered in the U.S. and other countries. iPhone is a trademark of Apple Inc.

About SIRIUS



SIRIUS and the SIRIUS-Ready logo are registered trademarks of SIRIUS Satellite Radio Inc.

About Neural – THX Surround



Neural-THX® Surround is taking surround sound to the next level. This revolutionary new technology delivers the rich envelopment and discrete image detail of surround sound in a format that is fully compatible with stereo from various content sources. Neural-THX Surround enables 5.1, 6.1 and 7.1-channel support for gaming, movies and digital music. By unmasking the audio details, typically lost by other playback modes, audiences will experience the deep ambience and subtle details of movies, music and games.

Neural-THX® Digital Music™ is a new surround mode specifically designed to enhance the playback of compressed digital music content. It provides listeners with an expanded sound stage and clean surround experience, even with compressed audio sources such as MP3s and Internet streams.

Neural-THX Surround has been chosen as the official surround sound format for TV sports broadcasting, 7.1 games, Music Direct Internet streaming as well as leading FM/HD radio stations worldwide. And with this technology being used by sound designers during content creation, as well as embedded into playback devices, Neural-THX Surround promises a listening experience that is true to the original mix.

For additional information, please visit www.neuralsurround.com.

This product is manufactured under license from Neural Audio Corporation and THX Ltd. PIONEER Corporation hereby grants the user a non-exclusive, non-transferable, limited right of use to this product under USA and foreign patent, patent pending and other technology or trademarks owned by Neural Audio Corporation and THX Ltd. "Neural Surround", "Neural Audio", "Neural" and "NRL" are trademarks and logos owned by Neural Audio Corporation, THX is a trademark of THX Ltd., which may be registered in some jurisdictions. All rights reserved.

Auto Surround, ALC and Stream Direct with different input signal formats

The following charts show what you will hear with different input signal formats, depending on the Stream Direct mode (see *Using Stream Direct* on page 56) you have selected.

Stereo (2 channel) signal formats

Input signal format	Auto Surround / ALC / DIRECT	PURE DIRECT
Surround Back speaker(s): Connected		
Dolby Digital Surround	⏏ Pro Logic IIx MOVIE	⏏ Pro Logic IIx MOVIE
DTS Surround	Neo:6 CINEMA	Neo:6 CINEMA
Other stereo sources	Stereo playback	Stereo playback
Analog sources	As above	ANALOG DIRECT (stereo)
PCM sources	As above	Stereo playback
DVD-A sources	As above	As above
SACD sources	As above	As above
Surround Back speaker(s): Not connected		
Dolby Digital Surround	⏏ Pro Logic II MOVIE	⏏ Pro Logic II MOVIE
DTS Surround	Neo:6 CINEMA	Neo:6 CINEMA
Other stereo sources	Stereo playback	Stereo playback
Analog sources	As above	ANALOG DIRECT (stereo)
PCM sources	As above	Stereo playback
DVD-A sources	As above	As above
SACD sources	As above	As above

Multichannel signal formats

Input signal format	Auto Surround / ALC	PURE DIRECT / DIRECT
Surround Back speaker(s): Connected		
Dolby Digital EX (6.1 channel flagged)	Dolby Digital EX ⏏ Pro Logic IIx MOVIE ^a	Dolby Digital EX ⏏ Pro Logic IIx MOVIE ^a
DTS-ES (6.1 channel sources/6.1 channel flagged)	DTS-ES (Matrix/Discrete)	DTS-ES (Matrix/Discrete)
DTS sources (5.1 channel encoding)	DTS+ Neo:6	Straight decoding
DTS-HD sources	Straight decoding	As above
Other 6.1/7.1 channel sources	As above	As above
Other 5.1 channel sources	Dolby Digital EX ⏏ Pro Logic IIx MOVIE ^a	As above
Surround Back speaker(s): Not connected		
DVD-A sources/Multi-ch PCM	Straight decoding	Straight decoding
SACD sources (5.1 channel encoding)	As above	As above
Other 5.1/6.1/7.1 channel sources	As above	As above

a. Unavailable with only one surround back speaker connected.

Preset code list

You should have no problem controlling a component if you find the manufacturer in this list, but please note that there are cases where codes for the manufacturer in the list will not work for the model that you are using. There are also cases where only certain functions may be controllable after assigning the proper preset code.

TV

General

- Pioneer** 10166, 10679, 11260, 11398
A-Mark 10047, 10054, 10160
A.R. Systems 10556
Accuscan 10047
Admiral 10047, 10054, 10017, 10051, 10093, 10463, 10180
Adventuri 10000
Agna 10150
Aiko 10092
Akai 10812, 11675, 10060, 10702, 10145, 10672
Alba 10037
Alfide 10672
Ambassador 10150
America Action 10180
American High 10000, 10060
Amstrad 10171
Amtron 10000, 10180
Anam 10180
AOE 10180, 11365
Apex Digital 10156, 10765, 10890, 11217
AR 10556
Audinac 10180
Audiovox 10451, 10180, 10092, 10623, 10802, 10875
Aventura 10171
Barco 10556
Baysonic 10180
Beaumarck 10017, 10178
Bell & Howell 10054, 10154, 10093
BenQ 11574
Blue Sky 10556
Bradford 10180
Brockwood 10178
Broksonic 10236, 10463, 10180
By:sign 11309
Capehart 10017, 10178, 10092
Carver 10054
CCE 10037
Celebrity 10000
Celera 10765
Changhong 10156, 10765
Cineral 10451, 10092
Citek 10047
Citizen 10000, 10054, 10451, 10463, 10180, 10060, 10171, 10092
Clarion 10180
Classic 10092
Colortyme 10047, 10054, 10017, 10060, 10178
Commercial Solutions 11447, 10047
Conic 10178
Contec 10180
Craig 10180, 10171
Crosley 10000, 10054, 10180, 10171
Crown 10093, 10180, 10672
Crown Mustang 10672
Curtis Mathes 10000, 10047, 10054, 10154, 10051, 10451, 10093, 10180, 10060, 10702, 10178, 10145, 10166, 10037, 11147
CXC 10180
Daewoo 11755, 10451, 10178, 10092, 11661, 10623, 10661, 10672, 11756
Dayton 10092
Daytron 10178, 10092
Dell 11264, 11080, 11178, 11403
Denon 10145
Dumont 10017, 10180, 10178
Durabrand 10463, 10180, 10178, 10171
Dwin 10093
Dynex 11463, 12049
Eaton 10060
Electroband 10000
Electrograph 11755
Electrohome 10000, 10154, 10463, 10150, 10178
Element 11687
Emerald 10178
Emerson 10047, 10017, 10154, 10451, 10236, 10463, 10180, 10150, 10178, 10171, 10623, 11394
Envision 11365
ESA 10812, 10171
Ferguson 10625
Fisher 10000, 10054, 10154
Fortress 10093
Fujitsu 10809, 10683, 10853
Funai 10000, 10180, 10171, 11271
Futuretech 10180
Gateway 11755, 11756
GE 10000, 11447, 10047, 10051, 10451, 10060, 10178, 11147
Gemini 10047
GFM 10171
Gibraltar 10000, 10017
GoldStar 10047, 10054, 10178, 10037
Goodmans 10037
Gradiente 10053
Granada 10037
Grundig 10037, 10672, 10683
Grundy 10180
Grunpy 10180
Haier 11748
Hallmark 10236, 10180, 10178
Hannspree 11351
Hanseatic 10556
Harley Davidson 10000, 10180, 10060, 10178
Harman/Kardon 10054
Harvard 10180
Havermy 10093
Heathkit 10017
Helios 10865
Hello Kitty 10451
Hewlett Packard 11494, 11101, 11502
Hitachi 10000, 11643, 10047, 10054, 10017, 10051, 11145, 10145, 11576
HP 11494, 11101, 11502
Hyundai 10865
Ima 10236, 10180, 10178
Infinity 10054
Innova 10037
Insignia 11423, 11564, 10171, 11517, 11710, 12049
Inteq 10017, 10145
JBL 10054
JCB 10000
Jinjing 10037, 10556
JVC 10054, 10053, 10160, 10650, 10731, 11253, 11601, 11633, 11774
Kamp 10017, 10180
KDS 11498, 11687
KEC 10180, 10060
Kenwood 10180
Kioto 10556
KLH 10156, 10180, 10765
Konka 10180
KTV 10463, 10180
Lark 10154
LG 11423, 10054, 10017, 11265, 10060, 10178, 10037, 10856, 11178, 11663, 11768
Lloyd's 10236, 10180
Loewe 10633
Logik 10236, 10180
Lumatron 10037, 10556
LXI 10000, 10047, 10054, 10017, 10154, 10156, 10051, 10093, 10060, 10053, 10178, 10171, 10166, 10037
MAG 11498, 11687
Magnasonic 10000, 10054, 10156, 10093, 10092
Magnavox 10000, 10250, 11454, 11866, 11755, 10047, 10054, 10154, 10051, 10180, 10060, 10171, 10092, 10802, 11254, 11365, 10037
Majestic 10017
Marantz 11454, 10054, 10037, 10556, 10704, 10855, 11398
Mark 10037

- Matsui** 10037
Matsushita 10250, 10051, 10650
Maxent 11755, 11211, 11756, 11757
Megatron 10047, 10178, 10145
Memorex 10154, 10463, 10180, 10150, 10178, 10037
Mermaid 10037
MGA 10150, 10178
MGN Technology 10178
Micro Genius 10150
Midland 10047, 10017, 10051
Minato 10037, 10556
Mitsubishi 10154, 11250, 10093, 10150, 10178, 10160, 10836
Motorola 10054, 10051, 10093, 10150
MTC 10180, 10060, 10092
Multitech 10180
NAD 10156, 10178, 10166, 10037, 11156
National 10226
NEC 10047, 10178, 10704, 11398, 11704, 11797
NetTV 11755
Nikko 10178, 10092
Nikkodo 10178, 10092
Norcent 11365
NTC 10092
Nyon 10000
Olevia 11610, 11144, 11240, 11331
Onwa 10180
Optimus 10250, 10154, 10093, 10180, 10150, 10178, 10166, 10650
Optonica 10093
Orion 10017, 10236, 10463, 10180, 10178, 11463
Pace 10092
Pacific 10037, 10556
Panasonic 11480, 10250, 10054, 10156, 10051, 10236, 10226, 10650, 11310, 11636, 11650
Paxonic 10060
PCE 10156, 10060
Penney 10000, 10250, 10047, 10156, 10051, 10060, 10178, 10037
Petters 11523
Philco 10054, 10463, 10145, 10171, 11271, 11394
Philips 11454, 10054, 10171, 10037, 10556, 10605, 10690, 11254, 11506, 11744
Pilot 10051, 10060, 10178
Polaroid 11523, 10765, 10865, 11276, 11314, 11498, 11687, 11766
Portland 10451, 10092
Precision 10236, 10180
Prism 10250, 10051
Proscan 11447, 10047
Protex 10037
Proton 10178
Proview 11498, 11687
ProVision 10037, 10556
Pulsar 10017, 10092
Pulser 10178, 10092
Quartz 10150, 10178
Quasar 10250, 10051, 10650
R-Line 10037
Rabbit 10047
RadioShack 10047, 10154, 10180, 10150, 10178
RCA 10000, 11547, 11447, 10047, 10054, 10051, 10093, 10178, 10090, 10679, 11047, 11147, 11247, 11781, 12187
Realistic 10047, 10154, 10180, 10150, 10178
Revox 10037
Runco 10017, 10060, 11398
Sampo 11755, 10047, 11756
Samsung 10812, 10047, 10054, 10017, 10154, 10060, 10702, 10178, 12051, 11619, 11235, 11060, 10814, 10766, 10650, 10587, 10037
Sanky 10060
Sansui 10463, 10060, 10171
Sanyo 10000, 11755, 10047, 10054, 10154, 10463, 10171, 10037, 11142
Saville 10060
Sceptre 11217, 11360
Scotch 10178
Scott 10236, 10180, 10178
Sears 10000, 10047, 10054, 10017, 10154, 10156, 10051, 10093, 10060, 10053, 10178, 10171, 10166, 10037
Seleco 11351
Sharp 10818, 10054, 10093, 10180, 11393
Sheng Chia 10093
Shivaki 10178, 10037, 10556
Siemens 10145
Signature 10047, 10093
Simpson 10178
Singer 10060, 10092
Sky-North 10037
Solar Drape 10000
Sony 10810, 10000, 10017, 10154, 10150, 10053, 11651, 11685
Soundesign 10180, 10178
Spectravision 10156, 10178
Spectroniq 11498, 11687
Squareview 10171
SR2000 10154, 10171
SSS 10180
Starlite 10236, 10180
Superscan 10093, 10864
Supreme 10000
SV2000 10054
SVA 10587, 10865
Sylvania 10000, 11864, 10047, 10054, 10154, 10051, 10178, 10171, 10092, 10037, 11271, 11314, 11394
Symphonic 10000, 10180, 10178, 10171
Syntax 11610, 11144, 11240, 11331
Tandy 10093
Tatung 10000, 10051, 10037, 11101, 11756
Teac 10154, 10037
Technics 10250, 10054, 10051, 10226
Techwood 10250, 10051, 10060
Teknika 10054, 10463, 10180, 10150, 10060, 10178, 10092
Telecolor 10017
Telefunken 10702, 10625
Tevion 10037, 10556
Thomas 10047, 10178
Thomson 11447, 10047, 10625
TMK 10236, 10180, 10178
TNCI 10017
Tocom 10156
Toshiba 11524, 10154, 10156, 11256, 10150, 11265, 10060, 11145, 10145, 10166, 10650, 10845, 11156, 11656, 11704
Totevision 10051
Toyomenka 10178
Truetone 10250, 10051
TVS 10463
Ultra 10092
Universal 10047
Universum 10037
V 11755, 10864, 10885, 11756
Victor 10053, 10160
Vidikron 10054, 11398, 11633
Vidtech 10178
Viewsonic 11755, 10857, 10864, 10885
Viking 10060
Viore 10054
Vizio 11758, 11755, 10864, 10885, 11756
Wards 10000, 10047, 10054, 10017, 10154, 10051, 10093, 10236, 10178, 10166, 10037, 11156
Waycon 10156
Welton 10178
Westinghouse 10000, 11712, 10451, 10885, 10889, 10890, 11282, 11577
White Westinghouse 10451, 10236, 10463, 10623, 10889
World 10451, 10236, 10463, 10180
Wyse 11365
XR-1000 10154, 10180, 10171
Yamaha 10650
Zenith 10000, 10812, 11423, 10047, 10017, 10093, 10463, 11265, 10178, 11145, 10145, 10171, 10092, 10037, 10160

Plasma Television

Pioneer 10679, 11260, 11398, 11633, 14000, 14001, 14003, 14004
Akai 10812, 11675
Daewoo 10661
Dell 11264
Electrograph 11755
ESA 10812
Fujitsu 10809, 10683, 10853
Funai 11271
Gateway 11755, 11756
Haier 11748
Helios 10865
Hewlett Packard 11502
Hitachi 11643
HP 11502
Insignia 11564
JVC 10731
LG 11423, 10178, 10856
Magnavox 11866
Marantz 10704, 11398
Maxent 11755, 11757
Mitsubishi 10836
NEC 11398, 11704
NetTV 11755
Panasonic 11480, 10250, 10650
Philips 10690, 11744
Polaroid 10865, 11276
Runco 11398
Sampo 11755
Samsung 10812, 12051
Sanyo 11142
Sony 10810, 10000
SVA 10865
Sylvania 11271, 11394
Tatung 11101, 11756
Toshiba 10650, 11704
Viewsonic 11755
Vizio 11758, 11756
Zenith 10178

LCD

Pioneer 11260
Akai 11675
AOC 11365
Apex Digital 10890, 11217
Audiovox 10180, 10802, 10875
Byd:sign 11309
Dell 11264, 11080, 11178
Dynex 12049
Element 11687
Emerson 11394
Envision 11365
Funai 10171
Haier 11748
Hannspree 11351
Hitachi 11643
Insignia 11564, 11517, 11710, 12049
JVC 11601, 11774
LG 11423, 10856, 11178, 11768
Magnavox 11866, 10802, 11365
Marantz 10855
Maxent 11755, 11211, 11757
Mitsubishi 11250
NEC 11797
Norcent 11365
Olevia 11610, 11144, 11240, 11331
Panasonic 11480, 10650
Petters 11523
Philips 11454, 11744
Polaroid 11523, 11276, 11498, 11687, 11766
RCA 10047, 11781, 12187
Sampo 11755
Samsung 10812, 10766, 10814, 12051
Sanyo 11142

Sceptre 11217, 11360
Sharp 10818, 10093
Sony 10810, 11685
Superscan 10864
SVA 10587
Sylvania 11864, 10171, 11271, 11314, 11394
Symphonic 10171
Syntax 11610, 11144, 11240, 11331
Toshiba 11524, 10845, 11656
Vidikron 11398
Viewsonic 10857, 10864, 10885
Vizio 11758, 10864, 10885, 11756
Westinghouse 11712, 10885, 10889, 10890, 11282, 11577
Wyse 11365
Zenith 11265

HDTV

Pioneer 10679
Mitsubishi 10150
Olevia 11610
Panasonic 10250, 10650
RCA 11447
Samsung 10812, 10702
Toshiba 11256

Rear Projection TV

Akai 10812, 10702
Apex Digital 10765
Hitachi 11145
JVC 11601
Mitsubishi 11250
Panasonic 10250
RCA 11447
Samsung 10812
Sony 10810
Toshiba 10156, 11656

TV/DVD Combination

Akai 11675
Dynex 12049
Emerson 11394
Insignia 12049
Magnavox 11866
Polaroid 11523, 11766
RCA 12187
Sylvania 11864, 11394
Toshiba 11524

TV/VCR Combination

America Action 10180
Audiovox 10180
Emerson 10236

DVR/VCR

General

Pioneer 20162, 20081, 20042, 20067, 20058, 22306, 22465, 22466, 22467
A-Mark 20037, 20000, 20278
ABS 21972
Accurian 20000
Admiral 20060, 20039
Adventura 20037, 20000
Aiko 20278
Aiwa 20037, 20000
Alba 20278
Alienware 21972
Allegro 20039
America Action 20278
American High 20035, 20081
Amstrad 20000
Anam National 20226
Astra 20035
Audio-Technica 20058
Audiovox 20037, 20278, 20038
Avis 20000
Bell & Howell 20035, 20039, 20000
Broksonic 20348, 21479
Calix 20037
Candle 20037, 20038
Canon 20035
Carver 20035, 20081
CCE 20278
Cineral 20278
Citizen 20035, 20037, 20000, 20278
Classic 20037
Colortyme 20060, 20035, 20045, 20278
Colt 20000
Craig 20037
Criterion 20000
Crosley 20035, 20081, 20000
Crown 20278
Curtis Mathes 20060, 20035, 20162, 20000, 20278
CyberPower 21972
Daewoo 20037, 20045, 20278
Daytron 20037, 20278
Dell 21972
Denon 20081, 20042
DirectTV 20739
Dual 20000
Durabrand 20039, 20038

Dynatech 20000
Electrohome 20060, 20037, 20000, 20043
Electrohome 20037
Emerex 20032
Emerson 20037, 20000, 20043, 20278, 20348, 21479, 21593
Fisher 20039, 20000
Fuji 20035, 20033
Fujitsu 20000
Funai 20037, 20000, 20278, 21593
Garrard 20000
Gateway 21972
GE 20060, 20035, 20000, 20807
Gemini 20060
Genexa 20037, 20000, 20278
GFM 21593
Go Video 20614
GoldStar 20035, 20037, 20039, 20000, 20278, 20038
Goodmans 20037, 20081, 20000, 20278
Gradiente 20000
Granada 20081, 20042
Grundig 20081, 20226
Harley Davidson 20000
Harman/Kardon 20081, 20038
Hewlett Packard 21972
HI-Q 20035, 20000
Hitachi 20035, 20037, 20045, 20000, 20042
Howard Computers 21972
HP 21972
Hughes Network Systems 20739, 20042
Humax 20739
Hush 21972
Hytek 20000
iBUYPOWER 21972
Instant Replay 20035, 20226
Jensen 20067
JVC 20067, 20058, 21162
KEC 20037, 20278
Kenwood 20067, 20038
Kodak 20035, 20037
KTV 20000
LG 20037, 20038
Lifetec 20348
Linksys 21972
Lloyd's 20000, 20038

Loewe 20081
Logik 20000
Lumatron 20278
LXI 20037, 20000, 20042, 20067
Magnasonic 20037, 20000, 20278
Magnavox 20035, 20037, 20039, 20081, 20000, 20226, 20618, 21593
Marantz 20035, 20081, 20038
Marta 20037
Matsui 20037, 20348
Matsushita 20035, 20162, 20081, 21162
Media Center PC 21972
Medion 20348
MEI 20035
Memorex 20035, 20162, 20037, 20039, 20000, 20278, 20348, 21162
Metz 20037
MGA 20060, 20043
Microsoft 21972
Mind 21972
Minolta 20042
Mitsubishi 20060, 20000, 20042, 20067, 20043, 20807
Motorola 20035
MTC 20000
MTX 20000
Multitech 20039, 20000
NAD 20058
NEC 20067, 20038
Nikko 20037, 20278
Nikkodo 20037, 20278
Niveus Media 21972
Northgate 21972
Olympus 20035, 20162, 20226
Onkyo 20222
Optimus 21062, 20035, 20162, 20037, 20000, 20058, 21162
Orion 20000, 20278, 21479
Panama 20035
Panasonic 21062, 20035, 20162, 20000, 20225, 20226, 20614, 20616, 21162, 21244, 21293, 21562
Penney 20035, 20162, 20037, 20081, 20000, 20042, 20067, 20038
Pentax 20042
Philco 20035, 20081, 20000

Philips 20739, 20035, 20162, 20081, 20045, 20000, 20616, 20618
Pilot 20037
Polk Audio 20081
Portland 20278
Presidian 21593
Proscan 20060
Protec 20000
Pulsar 20039, 20278
Quartz 20035
Quasar 20035, 20162, 20226, 21162
RadioShack 20035, 20162, 20037, 20000, 21162
Radix 20037
Randex 20037
RCA 20060, 20035, 20045, 20000, 20042, 20058, 20807, 20880
Realistic 20035, 20162, 20037, 20000, 20278, 21162
ReplayTV 20614, 20616
Ricavision 21972
Runco 20039
Samsung 20739, 20060, 20045, 20000, 20038, 21014
Sanky 20039
Sansui 20000, 20067, 21479
Sanyo 20000
Scott 20045, 20043
Sears 20060, 20035, 20162, 20037, 20039, 20033, 20045, 20000, 20042, 20067, 20043, 20058
Sharp 20032, 20000, 20807
Shintom 20039, 20000
Siemens 20037
Signature 20060, 20035, 20037, 20000
Singer 20037
Sonic Blue 20614, 20616
Sony 20032, 20035, 20033, 20000, 20067, 20226, 20636, 21972
Soundmaster 20000
Stack 9 21972
STS 20042
SV2000 20000
SVA 20000
Sylvania 20035, 20081, 20000, 20043, 21593
Symphonic 20000, 21593
Systemax 21972
Tagar Systems 21972
Tandy 20000
Tashiko 20037

Tatung 20081, 20000, 20067
Teac 20000, 20067
Technics 20035, 20162, 20037, 20000
Teknika 20035, 20037, 20000
Thomas 20000
Thomson 20060
Tisonic 20278
Tivo 20739, 20618, 20636, 21996
TMK 20000
TNIX 20037
Toshiba 20045, 20000, 20043, 21972, 21996
Tosonic 20278
Totevision 20037
Touch 21972
Trix 20037
Ultra 20045, 20278
Vector 20045

Vector Research 20038
Victor 20067
Video Concepts 20045
Videomagic 20037
Video sonic 20000
Viewsonic 21972
Villain 20000
Voodoo 21972
Wards 20060, 20035, 20037, 20081, 20033, 20045, 20000, 20042, 20043, 20038, 20058
White Westinghouse 20000, 20278
XR-1000 20035, 20000
Yamaha 20038
Zenith 20037, 20039, 20033, 20000, 20278, 21479
ZT Group 21972

PVR

Pioneer 22306, 22465, 22466, 22467
ABS 21972
Alienware 21972
CyberPower 21972
Dell 21972
DirectTV 20739
Gateway 21972
Go Video 20614
Hewlett Packard 21972
Howard Computers 21972
HP 21972
Hughes Network Systems 20739
Humax 20739
Hush 21972
iBUYPOWER 21972
Linksys 21972
Media Center PC 21972

Microsoft 21972
Mind 21972
Niveus Media 21972
Northgate 21972
Panasonic 20614, 20616
Philips 20739, 20618
RCA 20880
ReplayTV 20614, 20616
Samsung 20739
Sonic Blue 20614, 20616
Sony 20636, 21972
Stack 9 21972
Systemax 21972
Tagar Systems 21972
Tivo 20739, 20618, 20636
Toshiba 21972, 21996
Touch 21972
Viewsonic 21972
Voodoo 21972
ZT Group 21972

DVD

General

Pioneer 30525, 30571, 30142, 30631, 30632, 31460, 31512, 31571, 32442
3D LAB 30503, 30539
A-Trend 30714
Accurian 30675, 31416
Acoustic Solutions 30730
Adcom 31094
AEG 30788
Aiwa 30533, 30641
Akai 30695, 30770, 30899
Alba 30672
Alco 30790
Allegro 30869
Amphion Media Works 30872
Amstrad 30713
AMW 30872
Apex Digital 30533, 30672, 30794, 30796, 30797, 30830, 31004, 31020, 31056, 31061
Arrgo 31023
Audiovox 30790
Awa 30730
BBK 31224
Bel Canto Design 31571
Black Diamond 30713
Blue Parade 30571
Blue Sky 30695, 30713
Brandt 30651
Broksonic 30695, 30868

Bush 30690
California Audio Labs 30490
Cambridge Soundworks 30690
Cat 30789
Celestial 31020
Centrex 30672, 31004
Cinea 30831
CineVision 30869, 31483
Citizen 30695, 31277, 31587, 32116
Clairtone 30571
Clatronic 30788
Coby 30778, 30852, 31086, 31107, 31321, 31351
Craig 30831
Creative 30503, 30539
CyberHome 30714, 30816, 30874, 31023, 31024, 31129, 31502, 31537
Daewoo 30784, 30714, 30770, 30869, 31172
Dansai 30770
Daytek 30872
Decca 30770
Denon 30490, 30634, 31634, 32258
Denver 30778
Diamond 30768
Digitor 31005
Digitrex 30672
Disney 30675, 31270
Dual 30675
Durabrand 30713, 31023

DVD2000 30521
Electrohome 32116
Elta 30690
Emerson 30591, 30675, 30821, 31268
Enterprise 30591
Entivo 30503, 30539
Enzer 30770
ESA 30821, 31268
Firstline 30651
Fisher 30670
Funai 30675, 31268, 31334
Gateway 31158
GE 30522, 30815
GFM 30675, 31268
Go Video 30573, 30744, 30741, 30783, 30869, 31044, 31075, 31158, 31304, 31483
GoldStar 30741, 30869
Goodmans 30790
Gradiente 30490, 30651
Grundig 30539, 30775
H & B 30850
Harman/Kardon 30582, 30702
Hello Kitty 30831
HiMAX 30843
Hitachi 30573, 30664, 31247, 31664, 31748
Hiteker 30672
Hoyo 30665
Humax 31500, 31588
Hyundai 30850

iLo 31348, 31472
Initial 31472
Insignia 30675, 31268, 32095, 32428
Integra 30571, 31769, 30627, 31634, 32147
IRT 30783
Jaton 30665
JBL 30702
JMB 30695
JSI 31423
JVC 30558, 30623, 30867, 31164, 31275, 31550
jWin 31051
Kawasaki 30790
Kenwood 30490, 30534
Kiss 30665, 30841
KLH 30790, 31020, 31149
Kloss 30533
Koss 30651, 31061, 31423
Kreisen 31421
Landel 30826
Lasonic 30627, 30789
Lescon 31533
LG 30591, 30741, 30869
Limit 30768
LiteOn 31058, 31158, 31416, 31656
Loewe 30511, 30741
Logix 30783
Magnasonic 30651, 30675

- Magnavox** 30503, 30539, 30646, 30675, 30713, 30821, 31140, 31268, 31354, 31472, 31506
Marantz 30503, 30539, 30675
McIntosh 31533, 31273
Medion 30651
Memorex 30695, 30831, 31270
MiCO 30723, 30751
Microsoft 30522, 32083
Minato 30752
Mintek 31472
Mitsubishi 31521, 30521
Monyka 30665
Mustek 30730
Myryad 30894
NAD 30741
Naiko 30770
Nakamichi 31222
NEC 30785, 30869
Next Base 30826
Nintaus 31051
Norcent 30872, 31107
Onkyo 30503, 31769, 30627, 30612, 31612, 31627, 32147
Opko 30575, 31224, 31525
Optimus 30571
Oritron 30651
Pacific 30768
Palsonic 30672, 30852
Panasonic 30490, 30503, 30571, 30632, 30703, 31010, 31011, 31362, 31462, 31490, 31579, 31641, 31762
Philco 30675, 30690, 30733
Philips 30503, 30539, 32056, 32084, 30646, 30585, 30675, 30713, 30854, 31158, 31260, 31267, 31340, 31354, 31506
PianoDisc 31024
Polaroid 31020, 31061, 31086
Polk Audio 30539
Portland 30770
Presidian 30675
Proceed 30672
Proscan 30522
ProVision 30778
Qwestar 30651
Radionette 30741
RadioShack 30571
Raite 30665
RCA 30522, 30571, 31769, 30790, 30822, 31022
Realistic 30571
Redstar 30763
Reoc 30752
Rio 30869
Rotel 30623, 31178
Rowa 31004
Saba 30651
Sampo 30752
Samsung 30490, 30573, 30744, 30199, 30820, 30899, 31044, 31075, 31748, 32329
Sansui 30695
Sanyo 30670, 30675, 30695, 31334
Schmartz 32367
Schneider 30783
Schwaiger 30752
Sensory Science 31158
Sharp 30630, 30675, 30752, 31256, 32250
Sherwood 30770
Shinsonic 30533
Singer 30751
Skyworth 30898, 32148
Slim Art 30784
SM Electronic 30690, 30730
Sonic Blue 30573, 30783, 30869
Sony 31533, 30533, 30864, 31033, 31069, 31070, 31431, 31516, 31536
Superscan 30821
Sylvania 30675, 30821, 31268, 32194
Symphonic 30675, 30821, 31268, 31334
TAG McLaren 30894
Tatung 30770
Teac 30571, 30759, 30790
Technics 30490, 30703
Technika 30770
Technosonic 30730
Tevion 30651
Theta Digital 30571
Thomson 30522, 30511, 30551
Tivo 31503, 31512, 31588
Tokai 30665
Toshiba 30503, 30573, 30539, 31769, 30695, 31045, 31154, 31503, 31510, 31515, 31588, 31608, 32277
Tredex 30843
Unimax 30770
United 30730, 30788
Universum 30591, 30779
Urban Concepts 30503, 30539
V 31064, 31226
Venturer 30790
Vizio 31064, 31226
Xbox 30522, 32083
Yamaha 30490, 30539, 30646, 30545, 30497, 30817
Yamakawa 30665, 30710, 30872
Zenith 30503, 30591, 30741, 30869
Zeus 30784
Blu-ray
Pioneer 30142, 32442
Denon 32258
Insignia 30675, 32428
Integra 32147
LG 30741
Magnavox 30675
Onkyo 32147
Panasonic 31641
Philips 32084
Sharp 32250
Sony 31516
Sylvania 30675
HD-DVD
Integra 31769
LG 30741
Microsoft 32083
Onkyo 31769
RCA 31769
Toshiba 31769, 31515
Xbox 32083
DVD-R
Pioneer 30631, 31460, 31512
Accurian 30675, 31416
Apex Digital 31056
Citizen 32116
Coby 31086
CyberHome 31129, 31502
Electrohome 32116
Funai 30675, 31334
Gateway 31158
Go Video 30741, 31158, 31304
Humax 31588
iLo 31348
JVC 31164, 31275
Kreisen 31421
LG 30741
LiteOn 31158, 31416
Magnavox 30646, 30675, 31506
Panasonic 30490, 31010, 31011, 31579
Philips 30646, 31340
Polaroid 31086
RCA 30522
Samsung 30490
Sanyo 30670
Sensory Science 31158
Sharp 30675
Sony 31033, 31069, 31070, 31431, 31536
Sylvania 30675
Toshiba 31510, 31588, 32277
Zenith 30741
DVD/PVR Combination
Pioneer 30631, 31512
Humax 31500, 31588
LG 30741
Panasonic 30490, 31010, 31011
Philips 31340
RCA 30522
Sharp 31256
Sony 31033, 31069, 31070, 31536
Sylvania 30675
Tivo 31512
Toshiba 31503, 31510, 31588

DVD/VR**Combination**

Pioneer 31460
Accurian 30675
Allegro 30869
Apex Digital 31061
Broksonic 30695
CineVision 30869, 31483
Daewoo 30869

Emerson 30675
Funai 30675
GFM 30675
Go Video 30744, 30741, 30869, 31044, 31075, 31483
GoldStar 30741
Hitachi 30664
JVC 30867, 31164, 31550
LG 30741

LiteOn 31656
Magnavox 30675
Memorex 30695
Panasonic 31762
Philips 30675, 31267
Polaroid 31061
Presidian 30675
RCA 30522, 30822
Samsung 30820, 31044, 31075

Sansui 30695
Sanyo 30670
Sharp 30630
Sony 30864, 31033, 31069, 31070, 31431
Sylvania 30675
Symphonic 30675
Toshiba 30503
Zenith 30741, 30869

CD**General**

Pioneer 71063, 70032, 71087, 70468, 73468
Aiwa 70157
Arcam 70157
Audio Research 70157
Cairn 70157
California Audio Labs 70029
Cambridge Soundworks 70157
Carver 70157
Curtis Mathes 70032
Denon 70034, 70766
DKK 70000
DMX Electronics 70157
Fisher 70000
Genexxa 70032
Grundig 70157
Harman/Kardon 70100, 70157
Hitachi 70032
Inkel 70157, 70180
Integra 70101
JVC 70032, 70072
Kenwood 70626, 70000, 70029, 70028, 70037
Krell 70157
Linn 70157

Magnavox 70157
Marantz 70626, 70029, 70157, 70180
Matsui 70157
MCS 70029
Memorex 70000, 70032, 70468
Micromega 70157
Miro 70000
Mission 70157
Modulaire 70000, 70032, 70087, 70180, 70468
Myryad 70157
NSM 70157
Onkyo 70868, 71327, 70101, 70102, 70138, 70381, 71322, 71323
Optimus 71063, 70000, 70032, 70037, 70087, 70468
Panasonic 70029, 70388, 70752
Penney 70029
Philips 70626, 70157
Polk Audio 70157
Proton 70157
QED 70157
Quad 70157
Quasar 70029

RadioShack 70000, 70032, 70180, 70468
RCA 70032, 70053, 70468
Realistic 70000, 70032, 70087, 70180, 70468
Revox 70157
Rotel 70157
SAE 70157
Sansui 70000, 70157
Sanyo 70000, 70087
Sharp 70037, 70180
Sherwood 70180
Sonic Frontiers 70157
Sony 70000, 70100, 71364
Sugden 70157
Sylvania 70157
Symphonic 70180
TAG McLaren 70157
Tandy 70032
Teac 70180
Technics 70029
Thule Audio 70157
Victor 70072
Wards 70032, 70157, 70053, 70087
Yamaha 70868, 70036, 71292
Yorx 70000

CD-R

Pioneer 71087
Kenwood 70626
Marantz 70626
Onkyo 71322, 71323
Philips 70626
RCA 70053
Sony 70000, 70100, 71364
Yamaha 71292
MD
Pioneer 71063
Onkyo 70868
Optimus 71063

Satellite Set Top Box

General

Pioneer 00329, 01308
Akai 00200
Allsat 00200
Amstrad 00847, 01113
Asat 00200
Austar 00642, 00879, 01176
Bell ExpressVu 00775
British Sky Broadcasting 00847
Canal 00853
Chaparral 00216
Crossdigital 01109
DirecTV 01377, 00392, 00566, 00639, 01639, 01142, 00247, 00749, 01749, 00819, 01856, 01076, 01108, 00099, 01109, 01392, 01414, 01442, 01609, 01640
Dish Network System 00775, 01505, 01775
Dishpro 00775, 01505, 01775
EchoStar 00775, 01505, 01775
Esat 00879
Expressvu 00775, 01775
Fortec Star 01821
Foxtel 00879

Funai 01377
GE 00566
GOI 00775, 01775
Gradiente 00887
Grundig 00173, 00847
Hitachi 00749, 00819
Houston 00775
HTS 00775, 01775
Hughes Network Systems 01142, 00749, 01749, 01442
Humax 01781, 01790
Indovision 00887
Innova 00099
ISkyB 00887
JVC 00775, 00492, 01775
LG 01414
Magnavox 00722
Marantz 00200
Mitsubishi 00749
Netsat 00099, 00887
Nokia 00723
Omega 00887
Pace 00847, 00887, 01175
Panasat 00879
Panasonic 00247, 00701, 00847

Pansat 01807
Philips 00775, 01142, 00749, 01749, 01076, 00722, 00099, 00200, 00847, 01442
Proscan 00392, 00566
RadioShack 00775, 00566
RCA 00775, 00392, 00566, 01142, 00143, 01291, 01392, 01442
Sagem 00820, 01114
Samsung 01377, 01142, 01276, 01108, 01109, 01442, 01609
Siemens 00173
SKY 00099, 00847, 00887, 01175
Sony 00639, 01639, 00847, 01640
Star 00887
Televisa 00887
Thomson 00392, 00566
Tivo 01142, 01442
Toshiba 00749, 01749, 00790
TPS 00820
UltimateTV 01392, 01640
Uniden 00722
ViewSat 01232
Zenith 01856, 01810

SAT/PVR Combination

Bell ExpressVu 00775
DirecTV 01377, 00392, 00639, 01142, 01076, 00099, 01392, 01442, 01640
Dish Network System 00775, 01505
Dishpro 00775, 01505
EchoStar 00775, 01505
Expressvu 00775
Hughes Network Systems 01142, 01442
Philips 01142, 01442
Proscan 00392
RCA 01392
Samsung 01442
Sony 00639, 01640
Tivo 01142, 01442
Zenith 01810

Cable Set Top Box

General

Pioneer 01877, 00877, 00144, 00533, 01021, 01782
A-Mark 00008, 00144
ABC 00237, 00008
Acorn 00237
Action 00237
Active 00237
Amino 01602, 01822
Archer 00237
BCC 00276
Century 00008
Cisco 01877, 00877, 01982
Comcast 01982
Digeo 02187
Director 00476
Fosgate 00276
GE 00144

General Instrument 00476, 00810, 00276
GoldStar 00144
Hitachi 00008
i3 Micro 01602
Insight 00476, 00810
Jerrold 00476, 00810, 00276
Macab 00817
Memorex 00000
Motorola 01376, 00476, 00810, 00276, 01106
Myrio 01602, 01822
Noos 00817
Nova Vision 00008
Novaplex 00008
Ono 01068
Pace 01877, 00877, 00237, 00008, 01060, 01068

Panasonic 00000, 00008, 00144, 00107, 01982
Paragon 00000, 00008, 00525
Penney 00000
Philips 01305, 00317
Pulsar 00000
Quasar 00000
RCA 01256
Regal 00276
Runco 00000
Samsung 00144
Scientific Atlanta 01877, 00877, 00237, 00000, 00008
Sejin 01602
Sony 01006
Sprucer 00144
Supercable 00276
Thomson 01256
Toshiba 00000

United Cable 00276
US Electronics 00276, 00008
Videoway 00000
Zenith 00000, 00525

**Cable/PVR
Combination**

Pioneer 01877
Amino 01822

Cisco 01877, 01982
Comcast 01982
Digeo 02187
General Instrument 00810
Jerrold 00810

Motorola 01376, 00810,
01106
Myrio 01822
Pace 01877, 00237
Panasonic 01982

RCA 01256
Scientific Atlanta 01877
Sony 01006
Supercable 00276
Thomson 01256

Laser Disc Player

Pioneer 30241, 32447
Denon 30241
Magnavox 30241
Mitsubishi 30241

Cassette Deck

Pioneer 40027, 42446
Aiwa 40029
Carver 40029
Denon 40076
Grundig 40029

Harman/Kardon 40029
JVC 40244
Kenwood 40070
Magnavox 40029
Marantz 40029

Onkyo 40135
Optimus 40027
Philips 40029
Polk Audio 40029
RCA 40027

Sansui 40029
Sony 40243
Wards 40027
Yamaha 40097

Digital Tape

Pioneer 40019
Onkyo 40019

Video Accessory

Pioneer 01010
2Wire 02045
ABS 01272
Accurian 01653
ADB 02586
Alienware 01272
Amino 01481
AT&T 02045
CyberPower 01272
Epson 01563
Gateway 01272

Hewlett Packard 01272
Howard Computers 01272
HP 01272
Hush 01272
iBUYPOWER 01272
Insignia 01415
KoolConnect 01481
LG 01415
Linksys 01272
Magnavox 01563
Media Center PC 01272
Microsoft 02049, 01272
Mind 01272
Motorola 01998, 01363

Niveus Media 01272
Northgate 01272
Panasonic 01120
Philco 01563
Ricavision 01272
Samsung 01190, 01490
Sharp 01010
Sony 01272, 01324
Stack 9 01272
SureWest 01481
Sylvania 01563
Systemax 01272

Tagar Systems 01272
Toshiba 01272
Touch 01272
Viewsonic 01272, 01329
Voodoo 01272
Xbox 02049
Zenith 01415
ZT Group 01272

Specifications

Amplifier section

Continuous average power output of 90 watts* per channel, min., at 8 ohms, from 20 Hz to 20 000 Hz with no more than 0.2 % total harmonic distortion.**

Front (stereo)	90 W + 90 W
Power output (1 kHz, 6 Ω, 0.05 %, 1 ch driven)	120 W per channel
Guaranteed speaker impedance	16 Ω to 8 Ω, less than 8 Ω to 6 Ω (setting required)

* Measured pursuant to the Federal Trade Commission's Trade Regulation rule on Power Output Claims for Amplifiers

** Measured by Audio Spectrum Analyzer

Audio Section

Input (Sensitivity/Impedance)	
LINE	284 mV/47 kΩ
Output (Level/Impedance)	
REC	284 mV/2.2 kΩ
Signal-to-Noise Ratio (IHF, short circuited, A network)	
LINE	100 dB
Signal-to-Noise Ratio [EIA, at 1 W (1 kHz)]	
LINE	81 dB

Tuner Section

Frequency Range (FM)	87.5 MHz to 108 MHz
Antenna Input (FM)	75 Ω unbalanced
Frequency Range (AM)	530 kHz to 1700 kHz
Antenna (AM)	Loop antenna (balanced)

Video Section

Signal level	
Composite	1 Vp-p (75 Ω)
Component Video	Y: 1.0 Vp-p (75 Ω), PB, PR: 0.7 Vp-p (75 Ω)
Corresponding maximum resolution	
Component Video	1080p (1125p) (Video convert off)

Digital In/Out Section

HDMI terminal	19-pin (Not DVI)
HDMI output type	5 V, 100 mA
USB terminal	USB2.0 Full Speed (Type A)
iPod terminal	USB, and Video (Composite)
SIRIUS antenna cable	8-pin mini DIN cable

Integrated control section

Control (SR) terminal	Ø 3.5 Mini-jack (MONO)
Control (IR) terminal	Ø 3.5 Mini-jack (MONO)
IR signal	High Active (High Level: 2.0 V)

Miscellaneous

Power requirements	AC 120 V, 60 Hz
Power consumption	350 W
In standby	0.5 W (KURO LINK OFF) 0.8 W (KURO LINK ON)

Dimensions

	420 mm (W) x 158 mm (H) x 349 mm (D) (16 ⁹ / ₁₆ in. (W) x 6 ¹ / ₄ in. (H) x 13 ³ / ₄ in. (D))
Weight (without package)	8.7 kg (19 lb 3 oz)

Furnished Parts Number

MCACC Setup microphone (APM7008)	1
Remote control unit (AXD7551 (VSX-1019AH)/ AXD7552 (VSX-919AH))	1
AA/IEC R6 dry cell batteries	2
iPod cable (ADE7129)	1
AM loop antenna	1
FM wire antenna	1
These operating instructions	



Note

- Specifications and the design are subject to possible modifications without notice, due to improvements.



Dear Customer:

Selecting fine audio equipment such as the unit you've just purchased is only the start of your musical enjoyment. Now it's time to consider how you can maximize the fun and excitement your equipment offers. This manufacturer and the Electronic Industries Association's Consumer Electronics Group want you to get the most out of your equipment by playing it at a safe level. One that lets the sound come through loud and clear without annoying blaring or distortion and, most importantly, without affecting your sensitive hearing.

Sound can be deceiving. Over time your hearing "comfort level" adapts to higher volumes of sound. So what sounds "normal" can actually be loud and harmful to your hearing. Guard against this by setting your equipment at a safe level BEFORE your hearing adapts.

To establish a safe level:

- Start your volume control at a low setting.
- Slowly increase the sound until you can hear it comfortably and clearly, and without distortion.

Once you have established a comfortable sound level:

- Set the dial and leave it there.

Taking a minute to do this now will help to prevent hearing damage or loss in the future. After all, we want you listening for a lifetime.

Cleaning the unit

- Use a polishing cloth or dry cloth to wipe off dust and dirt.
- When the surface is dirty, wipe with a soft cloth dipped in some neutral cleanser diluted five or six times with water, and wrung out well, and then wipe again with a dry cloth. Do not use furniture wax or cleansers.
- Never use thinners, benzene, insecticide sprays or other chemicals on or near this unit, since these will corrode the surface.

We Want You Listening For A Lifetime

Used wisely, your new sound equipment will provide a lifetime of fun and enjoyment. Since hearing damage from loud noise is often undetectable until it is too late, this manufacturer and the Electronic Industries Association's Consumer Electronics Group recommend you avoid prolonged exposure to excessive noise. This list of sound levels is included for your protection.

Decibel Level Example

30	Quiet library, soft whispers
40	Living room, refrigerator, bedroom away from traffic
50	Light traffic, normal conversation, quiet office
60	Air conditioner at 20 feet, sewing machine
70	Vacuum cleaner, hair dryer, noisy restaurant
80	Average city traffic, garbage disposals, alarm clock at two feet.

THE FOLLOWING NOISES CAN BE DANGEROUS UNDER CONSTANT EXPOSURE

90	Subway, motorcycle, truck traffic, lawn mower
100	Garbage truck, chain saw, pneumatic drill
120	Rock band concert in front of speakers, thunderclap
140	Gunshot blast, jet plane
180	Rocket launching pad

Information courtesy of the Deafness Research Foundation.



S001_En

This product includes FontAvenue® fonts licenced by NEC corporation. FontAvenue is a registered trademark of NEC Corporation



PIONEER ELECTRONICS (USA) INC.

PIONEER ELECTRONICS OF CANADA, INC.

LIMITED WARRANTY
WARRANTY VALID ONLY IN COUNTRY OF PRODUCT PURCHASE

WARRANTY

Pioneer Electronics (USA) Inc. (PUSA), and Pioneer Electronics Of Canada, Inc. (POC), warrant that products distributed by PUSA in the U.S.A., and by POC in Canada that fail to function properly under normal use due to a manufacturing defect when installed and operated according to the owner's manual enclosed with the unit will be repaired or replaced with a unit of comparable value, at the option of PUSA or POC, without charge to you for parts or actual repair work.

THIS LIMITED WARRANTY APPLIES TO THE ORIGINAL OR ANY SUBSEQUENT OWNER OF THIS PIONEER PRODUCT DURING THE WARRANTY PERIOD PROVIDED THE PRODUCT WAS PURCHASED FROM AN AUTHORIZED PIONEER DISTRIBUTOR/DEALER IN THE U.S.A. OR CANADA. YOU WILL BE REQUIRED TO PROVIDE A SALES RECEIPT OR OTHER VALID PROOF OF PURCHASE SHOWING THE DATE OF ORIGINAL PURCHASE OR, IF RENTED, YOUR RENTAL CONTRACT SHOWING THE PLACE AND DATE OF FIRST RENTAL. IN THE EVENT SERVICE IS REQUIRED, THE PRODUCT MUST BE DELIVERED WITHIN THE WARRANTY PERIOD, TRANSPORTATION PREPAID, ONLY FROM WITHIN THE COUNTRY OF PURCHASE AS EXPLAINED IN THIS DOCUMENT. YOU WILL BE RESPONSIBLE FOR REMOVAL AND INSTALLATION OF THE PRODUCT. PUSA OR POC, AS APPROPRIATE, WILL PAY TO RETURN THE REPAIRED OR REPLACEMENT PRODUCT TO YOU WITHIN THE COUNTRY OF PURCHASE.

PRODUCT WARRANTY PERIOD

Table with 2 columns: Product Category, Parts, Labor. Categories include Home Audio and Video, Microphones, Headphones, Phono Cartridges and Styluses.

Shorter limited warranty periods apply to some models. Please refer to the limited warranty document enclosed with the product for a definitive statement of the warranty period. The warranty period for retail customers who rent the product commences upon the date product is first put into use (a) during the rental period or (b) retail sale, whichever occurs first.

WHAT IS NOT COVERED

IF THIS PRODUCT WAS PURCHASED FROM AN UNAUTHORIZED DISTRIBUTOR, THERE ARE NO WARRANTIES, EXPRESS OR IMPLIED, INCLUDING THE IMPLIED WARRANTY OF MERCHANTABILITY AND THE IMPLIED WARRANTY OF FITNESS FOR A PARTICULAR PURPOSE AND THIS PRODUCT IS SOLD STRICTLY "AS IS" AND "WITH ALL FAULTS". PIONEER SHALL NOT BE LIABLE FOR ANY CONSEQUENTIAL AND/OR INCIDENTAL DAMAGES.

PIONEER DOES NOT WARRANT ANY PRODUCT LISTED ABOVE WHEN IT IS USED IN A TRADE OR BUSINESS OR IN ANY INDUSTRIAL OR COMMERCIAL APPLICATION.

THIS WARRANTY DOES NOT APPLY IF THE PRODUCT HAS BEEN SUBJECTED TO POWER IN EXCESS OF ITS PUBLISHED POWER RATING.

THIS WARRANTY DOES NOT COVER TELEVISION OR DISPLAY SCREENS DAMAGED BY STATIC, NON-MOVING, IMAGES APPLIED FOR LENGTHY PERIODS (BURN-IN).

THIS WARRANTY DOES NOT COVER THE CABINET OR ANY APPEARANCE ITEM, USER ATTACHED ANTENNA, ANY DAMAGE TO RECORDS OR RECORDING TAPES OR DISCS, ANY DAMAGE TO THE PRODUCT RESULTING FROM ALTERATIONS, MODIFICATIONS NOT AUTHORIZED IN WRITING BY PIONEER, ACCIDENT, MISUSE OR ABUSE, DAMAGE DUE TO LIGHTNING OR TO POWER SURGES, SUBSEQUENT DAMAGE FROM LEAKING, DAMAGE FROM INOPERATIVE BATTERIES, OR THE USE OF BATTERIES NOT CONFORMING TO THOSE SPECIFIED IN THE OWNER'S MANUAL.

THIS WARRANTY DOES NOT COVER THE COST OF PARTS OR LABOR WHICH WOULD BE OTHERWISE PROVIDED WITHOUT CHARGE UNDER THIS WARRANTY OBTAINED FROM ANY SOURCE OTHER THAN A PIONEER AUTHORIZED SERVICE COMPANY OR OTHER DESIGNATED LOCATION. THIS WARRANTY DOES NOT COVER DEFECTS OR DAMAGE CAUSED BY THE USE OF UNAUTHORIZED PARTS OR LABOR OR FROM IMPROPER MAINTENANCE.

ALTERED, DEFACED, OR REMOVED SERIAL NUMBERS VOID THIS ENTIRE WARRANTY

NO OTHER WARRANTIES

IN THE U.S.A. - PIONEER LIMITS ITS OBLIGATIONS UNDER ANY IMPLIED WARRANTIES INCLUDING, BUT NOT LIMITED TO, THE IMPLIED WARRANTIES OF MERCHANTABILITY AND FITNESS FOR A PARTICULAR PURPOSE, TO A PERIOD NOT TO EXCEED THE WARRANTY PERIOD. NO WARRANTIES SHALL APPLY AFTER THE WARRANTY PERIOD. SOME STATES DO NOT ALLOW LIMITATIONS ON HOW LONG AN IMPLIED WARRANTY LASTS AND SOME STATES DO NOT ALLOW THE EXCLUSIONS OR LIMITATIONS OF INCIDENTAL OR CONSEQUENTIAL DAMAGES, SO THE ABOVE LIMITATIONS OR EXCLUSIONS MAY NOT APPLY TO YOU. THIS WARRANTY GIVES YOU SPECIFIC LEGAL RIGHTS AND YOU MAY HAVE OTHER RIGHTS WHICH MAY VARY FROM STATE TO STATE.

IN CANADA - EXCEPT AS EXPRESSLY PROVIDED HEREIN, THERE ARE NO REPRESENTATIONS, WARRANTIES, OBLIGATIONS OR CONDITIONS, IMPLIED, STATUTORY OR OTHERWISE, APPLICABLE TO THIS PRODUCT.

TO OBTAIN SERVICE

PUSA and POC have appointed a number of Authorized Service Companies throughout the U.S.A. and Canada should your product require service. To receive warranty service you need to present your sales receipt or, if rented, your rental contract showing place and date of original owner's transaction. If shipping the unit you will need to package it carefully and send it, transportation prepaid by a traceable, insured method, to an Authorized Service Company. Package the product using adequate padding material to prevent damage in transit. The original container is ideal for this purpose. Include your name, address and telephone number where you can be reached during business hours. On all complaints and concerns in the U.S.A. call Customer Support at 1-800-421-1404, or, in Canada, call Customer Satisfaction at 1-877-283-5901.

IN THE U.S.A.

For hook-up and operation of your unit or to locate an Authorized Service Company, please call or write:

PIONEER ELECTRONICS SERVICE, INC.
P.O. BOX 1760
LONG BEACH, CALIFORNIA 90801
1-800-421-1404
http://www.pioneerelectronics.com

IN CANADA

For additional information on this warranty, please call or write:

CUSTOMER SATISFACTION GROUP
PIONEER ELECTRONICS OF CANADA, INC.
300 ALLSTATE PARKWAY
MARKHAM, ON L3R 0P2
(905) 479-4411
1-877-283-5901
http://www.pioneerelectronics.ca

DISPUTE RESOLUTION

IN THE U.S.A. - Following our response to any initial request to Customer Support, should a dispute arise between you and Pioneer, Pioneer makes available its Complaint Resolution Program to resolve the dispute. The Complaint Resolution Program is available to you without charge. You are required to use the Complaint Resolution Program before you exercise any rights under, or seek any remedies, created by Title 1 of the Magnuson-Moss Warranty-Federal Trade Commission Improvement Act, 15 U.S.C. 2301 et seq. To use the Complaint Resolution Program call 1-800-421-1404 and explain to the customer service representative the problem you are experiencing, steps you have taken to have the product repaired during the warranty period and the name of the authorized Distributor/Dealer from whom the Pioneer product was purchased. After the complaint has been explained to the representative, a resolution number will be issued. Within 40 days of receiving your complaint, Pioneer will investigate the dispute and will either: (1) respond to your complaint in writing informing you what action Pioneer will take, and in what time period, to resolve the dispute; or (2) respond to your complaint in writing informing you why it will not take any action.

IN CANADA - Call the Customer Satisfaction Manager at (905) 946-7446 to discuss your complaint and to obtain a prompt resolution.

RECORD THE PLACE AND DATE OF PURCHASE FOR FUTURE REFERENCE

Model No. _____ Serial No. _____ Purchase Date _____
Purchased From _____

KEEP THIS INFORMATION AND YOUR SALES RECEIPT IN A SAFE PLACE

Should this product require service in the U.S.A. and you wish to locate the nearest Pioneer Authorized Independent Service Company, or if you wish to purchase replacement parts, operating instructions, service manuals, or accessories, please call the number shown below.

1-800-421-1404

Please do not ship your product to Pioneer without first calling the Customer Support at the above listed number for assistance.

Pioneer Electronics Service, Inc.
P.O. BOX 1760, Long Beach,
CA 90801-1760, U.S.A.

For warranty information please see the Limited Warranty sheet included with your product.

Should this product require service in Canada, please contact a Pioneer Canadian Authorized Dealer to locate the nearest Pioneer Authorized Service Company in Canada. Alternatively, please contact the Customer Satisfaction Department at the following address:

Pioneer Electronics of Canada, Inc.
Customer Satisfaction Department
300 Allstate Parkway, Markham, Ontario L3R 0P2
1-877-283-5901
905-479-4411

For warranty information please see the Limited Warranty sheet included with your product.

Si ce produit doit être réparé au Canada, veuillez vous adresser à un distributeur autorisé Pioneer du Canada pour obtenir le nom du Centre de Service Autorisé Pioneer le plus près de chez-vous. Vous pouvez aussi contacter le Service à la clientèle de Pioneer:

Pioneer Électroniques du Canada, Inc.
Service Clientèle
300, Allstate Parkway, Markham, Ontario L3R 0P2
1-877-283-5901
905-479-4411

Pour obtenir des renseignements sur la garantie, veuillez vous reporter au feuillet sur la garantie restreinte qui accompagne le produit.

5018_C_EF

Published by Pioneer Corporation.
Copyright © 2009 Pioneer Corporation.
All rights reserved.

PIONEER CORPORATION

4-1, Meguro 1-Chome, Meguro-ku, Tokyo 153-8654, Japan

PIONEER ELECTRONICS (USA) INC.

P.O. BOX 1540, Long Beach, California 90801-1540, U.S.A. TEL: (800) 421-1404

PIONEER ELECTRONICS OF CANADA, INC.

300 Allstate Parkway, Markham, Ontario L3R 0P2, Canada TEL: 1-877-283-5901, 905-479-4411

PIONEER EUROPE NV

Haven 1087, Keetberglaan 1, B-9120 Melsele, Belgium TEL: 03/570.05.11

PIONEER ELECTRONICS ASIACENTRE PTE. LTD.

253 Alexandra Road, #04-01, Singapore 159936 TEL: 65-6472-7555

PIONEER ELECTRONICS AUSTRALIA PTY. LTD.

178-184 Boundary Road, Braeside, Victoria 3195, Australia, TEL: (03) 9586-6300

PIONEER ELECTRONICS DE MEXICO S.A. DE C.V.

Blvd.Manuel Avila Camacho 138 10 piso Col.Lomas de Chapultepec, Mexico,D.F. 11000 TEL: 55-9178-4270

K002_B_En

Free Manuals Download Website

<http://myh66.com>

<http://usermanuals.us>

<http://www.somanuals.com>

<http://www.4manuals.cc>

<http://www.manual-lib.com>

<http://www.404manual.com>

<http://www.luxmanual.com>

<http://aubethermostatmanual.com>

Golf course search by state

<http://golfingnear.com>

Email search by domain

<http://emailbydomain.com>

Auto manuals search

<http://auto.somanuals.com>

TV manuals search

<http://tv.somanuals.com>