

Pioneer *sound.vision.soul*

**AUDIO/VIDEO MULTI-CHANNEL
RECEIVER**

VSX-D814

VSX-D914

Operating Instructions

Thank you for buying this Pioneer product. Please read through these operating instructions so you will know how to operate your model properly. After you have finished reading the instructions, put them away in a safe place for future reference.

If the socket outlets on the associated equipment are not suitable for the plug supplied with the product, the plug must be removed and appropriate one fitted. Replacement and mounting of an AC plug on the power supply cord of this unit should be performed only by qualified service personnel. The cut-off plug must be disposed of as an electrical shock hazard could exist if connected to a socket outlet.

D3-4-2-1a_En

WARNING – TO PREVENT FIRE OR SHOCK HAZARD, DO NOT EXPOSE THIS APPLIANCE TO RAIN OR MOISTURE.

D1-4-2-1_En

CAUTION – PREVENT ELECTRIC SHOCK DO NOT USE THIS (POLARIZED) PLUG WITH AN EXTENSION CORD. RECEPTACLE OR OTHER OUTLET UNLESS THE BLADES CAN BE FULLY INSERTED TO PREVENT BLADE EXPOSURE.

ATTENTION – POUR PREVENIR LES CHOCs ELECTRIQUES NE PAS UTILISER CETTE FICHE POLARISEE AVEC UN PROLONGATEUR UNE PRISE DE COURANT OU UNE AUTRE SORTIE DE COURANT. SAUF SI LES LAMES PEUVENT ETRE INSEREES A FOND SANS EN LAISSER AUCUNE PARTIE A DECOUVERT.

D2-4-4-1_En

WARNING: Handling the cord on this product or cords associated with accessories sold with the product will expose you to lead, a chemical known to the State of California and other governmental entities to cause cancer and birth defects or other reproductive harm.

Wash hands after handling

D36-P4_En

IMPORTANT NOTICE – THE SERIAL NUMBER FOR THIS EQUIPMENT IS LOCATED IN THE REAR. PLEASE WRITE THIS SERIAL NUMBER ON YOUR ENCLOSED WARRANTY CARD AND KEEP IN A SECURE AREA. THIS IS FOR YOUR SECURITY.

D1-4-2-6-1_En

NOTE: This equipment has been tested and found to comply with the limits for a Class B digital device, pursuant to Part 15 of the FCC Rules. These limits are designed to provide reasonable protection against harmful interference in a residential installation. This equipment generates, uses, and can radiate radio frequency energy and, if not installed and used in accordance with the instructions, may cause harmful interference to radio communications. However, there is no guarantee that interference will not occur in a particular installation. If this equipment does cause harmful interference to radio or television reception, which can be determined by turning the equipment off and on, the user is encouraged to try to correct the interference by one or more of the following measures:

- Reorient or relocate the receiving antenna.
- Increase the separation between the equipment and receiver.
- Connect the equipment into an outlet on a circuit different from that to which the receiver is connected.
- Consult the dealer or an experienced radio/TV technician for help.

D8-10-1-2_En

This Class B digital apparatus complies with Canadian ICES-003.

Cet appareil numérique de la Classe B est conforme à la norme NMB-003 du Canada.

D8-10-1-3_EF

Information to User

Alteration or modifications carried out without appropriate authorization may invalidate the user's right to operate the equipment.

D8-10-2_En

CAUTION: This product satisfies FCC regulations when shielded cables and connectors are used to connect the unit to other equipment. To prevent electromagnetic interference with electric appliances such as radios and televisions, use shielded cables and connectors for connections.

D8-10-3a_En

Manufactured under license from Dolby Laboratories. "Dolby", "Pro Logic", "Surround EX", and the double-D symbol are trademarks of Dolby Laboratories.

"DTS", "DTS-ES Extended Surround" and "Neo:6" are trademarks of Digital Theater Systems, Inc.

For U.S. and Australia Model





The lightning flash with arrowhead, within an equilateral triangle, is intended to alert the user to the presence of uninsulated "dangerous voltage" within the product's enclosure that may be of sufficient magnitude to constitute a risk of electric shock to persons.

CAUTION
RISK OF ELECTRIC SHOCK
DO NOT OPEN



CAUTION:
TO PREVENT THE RISK OF ELECTRIC SHOCK, DO NOT REMOVE COVER (OR BACK). NO USER-SERVICEABLE PARTS INSIDE. REFER SERVICING TO QUALIFIED SERVICE PERSONNEL.

The exclamation point within an equilateral triangle is intended to alert the user to the presence of important operating and maintenance (servicing) instructions in the literature accompanying the appliance.

D1-4-2-3_En

IMPORTANT SAFETY INSTRUCTIONS

READ INSTRUCTIONS — All the safety and operating instructions should be read before the product is operated.

RETAIN INSTRUCTIONS — The safety and operating instructions should be retained for future reference.

HEED WARNINGS — All warnings on the product and in the operating instructions should be adhered to.

FOLLOW INSTRUCTIONS — All operating and use instructions should be followed.

CLEANING — The product should be cleaned only with a polishing cloth or a soft dry cloth. Never clean with furniture wax, benzene, insecticides or other volatile liquids since they may corrode the cabinet.

ATTACHMENTS — Do not use attachments not recommended by the product manufacturer as they may cause hazards.

WATER AND MOISTURE — Do not use this product near water — for example, near a bathtub, wash bowl, kitchen sink, or laundry tub; in a wet basement; or near a swimming pool; and the like.

ACCESSORIES — Do not place this product on an unstable cart, stand, tripod, bracket, or table. The product may fall, causing serious injury to a child or adult, and serious damage to the product. Use only with a cart, stand, tripod, bracket, or table recommended by the manufacturer, or sold with the product. Any mounting of the product should follow the manufacturer's instructions, and should use a mounting accessory recommended by the manufacturer.

CART — A product and cart combination should be moved with care. Quick stops, excessive force, and uneven surfaces may cause the product and cart combination to overturn.



VENTILATION — Slots and openings in the cabinet are provided for ventilation and to ensure reliable operation of the product and to protect it from overheating, and these openings must not be blocked or covered. The openings should never be blocked by placing the product on a bed, sofa, rug, or other similar surface. This product should not be placed in a built-in installation such as a bookcase or rack unless proper ventilation is provided or the manufacturer's instructions have been adhered to.

POWER SOURCES — This product should be operated only from the type of power source indicated on the marking label. If you are not sure of the type of power supply to your home, consult your product dealer or local power company.

LOCATION — The appliance should be installed in a stable location.

NONUSE PERIODS — The power cord of the appliance should be unplugged from the outlet when left un-used for a long period of time.

GROUNDING OR POLARIZATION

- If this product is equipped with a polarized alternating current line plug (a plug having one blade wider than the other), it will fit into the outlet only one way. This is a safety feature. If you are unable to insert the plug fully into the outlet, try reversing the plug. If the plug should still fail to fit, contact your electrician to replace your obsolete outlet. Do not defeat the safety purpose of the polarized plug.
- If this product is equipped with a three-wire grounding type plug, a plug having a third (grounding) pin, it will only fit into a grounding type power outlet. This is a safety feature. If you are unable to insert the plug into the outlet, contact your electrician to replace your obsolete outlet. Do not defeat the safety purpose of the grounding type plug.

POWER-CORD PROTECTION — Power-supply cords should be routed so that they are not likely to be walked on or pinched by items placed upon or against them, paying particular attention to cords at plugs, convenience receptacles, and the point where they exit from the product.

OUTDOOR ANTENNA GROUNDING — If an outside antenna or cable system is connected to the product, be sure the antenna or cable system is grounded so as to provide some protection against voltage surges and built-up static charges. Article 810 of the National Electrical Code, ANSI/NFPA 70, provides information with regard to proper grounding of the mast and supporting structure, grounding of the lead-in wire to an antenna discharge unit, size of grounding conductors, location of antenna-discharge unit, connection to grounding electrodes, and requirements for the grounding electrode. See Figure A.

LIGHTNING — For added protection for this product during a lightning storm, or when it is left unattended and unused for long periods of time, unplug it from the wall outlet and disconnect the antenna or cable system. This will prevent damage to the product due to lightning and power-line surges.

POWER LINES — An outside antenna system should not be located in the vicinity of overhead power lines or other electric light or power circuits, or where it can fall into such power lines or circuits. When installing an outside antenna system, extreme care should be taken to keep from touching such power lines or circuits as contact with them might be fatal.

OVERLOADING — Do not overload wall outlets, extension cords, or integral convenience receptacles as this can result in a risk of fire or electric shock.

OBJECT AND LIQUID ENTRY — Never push objects of any kind into this product through openings as they may touch dangerous voltage points or short-out parts that could result in a fire or electric shock. Never spill liquid of any kind on the product.

SERVICING — Do not attempt to service this product yourself as opening or removing covers may expose you to dangerous voltage or other hazards. Refer all servicing to qualified service personnel.

DAMAGE REQUIRING SERVICE — Unplug this product from the wall outlet and refer servicing to qualified service personnel under the following conditions:

- When the power-supply cord or plug is damaged.
- If liquid has been spilled, or objects have fallen into the product.
- If the product has been exposed to rain or water.
- If the product does not operate normally by following the operating instructions. Adjust only those controls that are covered by the operating instructions as an improper adjustment of other controls may result in damage and will often require extensive work by a qualified technician to restore the product to its normal operation.
- If the product has been dropped or damaged in any way.
- When the product exhibits a distinct change in performance — this indicates a need for service.

REPLACEMENT PARTS — When replacement parts are required, be sure the service technician has used replacement parts specified by the manufacturer or have the same characteristics as the original part. Unauthorized substitutions may result in fire, electric shock, or other hazards.

SAFETY CHECK — Upon completion of any service or repairs to this product, ask the service technician to perform safety checks to determine that the product is in proper operating condition.

WALL OR CEILING MOUNTING — The product should not be mounted to a wall or ceiling.

HEAT — The product should be situated away from heat sources such as radiators, heat registers, stoves, or other products (including amplifiers) that produce heat.

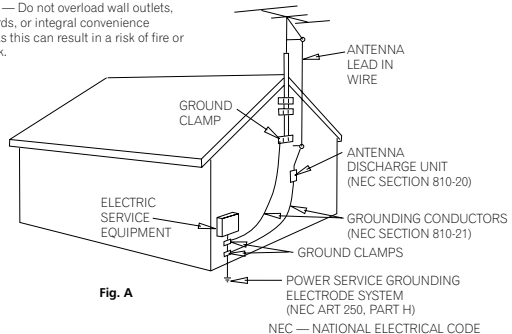

Fig. A

NEC — NATIONAL ELECTRICAL CODE

D1-4-2-2_En

Contents

01 Before you start

Checking what's in the box	6
Installing the receiver	6
Making cable connections	6
Loading the batteries	6
Operating range of remote control unit	7

02 5 minute guide

Introduction to home theater	8
Listening to Surround Sound	9
Using the Quick Setup	12

03 Quick surround sound setup

Automatically calibrating your listening area (MCACC)	14
---	----

04 Connecting up

Audio/Video cords	16
S-video cables	16
Component video cords	16
Digital audio coaxial cords/ Optical cables	16
Connecting digital components	17
Connecting audio components	18
Connecting DVD 5.1 channel components	18
Connecting video components	19
Connecting to the front panel video terminal	19
Connecting antennas	20
FM wire antenna	20
AM loop antenna	20
Using external antennas	20
Connecting the speakers	21
Speaker terminals	22
A and B speaker systems	22
Hints on speaker placement	22
Connecting additional amplifiers	24
AC outlet	25

Operating other Pioneer components	25
Using this receiver with a Pioneer plasma display	26

05 Controls and displays

Front panel	27
Display	29
Remote control	31

06 Listening to your system

Listening in surround sound	35
Using the Advanced surround effects	35
Listening in stereo	36
Choosing the input signal	37
Using the Surround Back Channel (SB CH)	38
Using the Virtual Surround Back mode (VSB)	39
Using Loudness and Midnight listening	40
Using the tone controls	40
Playing other sources	40
Selecting the multi-channel analog inputs	41
Using the sleep timer	41

07 Setting up the receiver

Choosing your receiver setup	42
Speaker setting	43
Surround back speaker setting	44
Subwoofer setting	44
Crossover frequency setting	44
LFE attenuator setting	45
Front left speaker distance setting	45
Center speaker distance setting	45
Front right speaker distance setting	46
Surround right speaker distance setting	46
Surround back speaker distance setting	46

Surround left speaker distance setting . .	46
Subwoofer distance setting	46
Dynamic range control setting	47
Dual mono setting	47
Component video input settings	47
Digital input settings	47
SR+ control for Pioneer plasma displays	48
Manually calibrating your listening area (MCACC)	49
Setting separate channel levels for listening modes	50
Using the SR+ mode with a Pioneer plasma display	51

08 Using the tuner

Listening to the radio	53
Improving FM stereo sound	53
Tuning directly to a station	53
Saving station presets	54
Naming station presets	54
Listening to station presets	55

09 Making recordings

Making an audio or a video recording	56
--	----

10 Controlling the rest of your system

Setting the remote to control other components	57
Selecting preset codes directly	57
Programming signals from other remote controls	58
Erasing one of the remote control button settings	59
Erasing all of the remote control presets	60
Direct function	60
Confirming preset codes	60
Controls for TVs	61
Controls for other components	62

11 Additional information

Troubleshooting	65
Resetting the main unit	67
Switching the speaker impedance	67
Specifications	68
Cleaning the unit	69

Chapter 1: Before you start

Checking what's in the box

Please check that you've received the following supplied accessories:

- AM loop antenna
- FM wire antenna
- AA/LR6 dry cell batteries x2
- Remote control
- These operating instructions
- Warranty Card

V SX-D914 model only:

- Microphone
- Microphone stand

Installing the receiver

Please note the following points:

- Do not place objects directly on top of this unit. This prevents proper heat dispersal.
- When installing on a rack, shelf, etc., be sure to leave more than 8 inches (20 cm.) of space above the receiver.

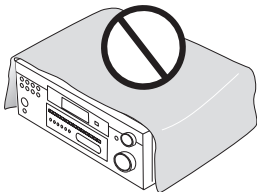

Making cable connections

Make sure not to bend the cables over the top of this unit (as shown in the illustration). If this happens, the magnetic field produced by the transformers in this unit may cause a humming noise from the speakers.

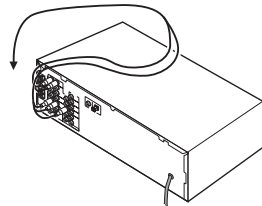

Loading the batteries

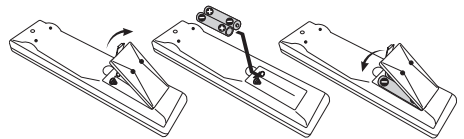

Caution

Incorrect use of batteries may result in such hazards as leakage and bursting. Observe the following precautions:

- Never use new and old batteries together.
- Insert the plus and minus sides of the batteries properly according to the marks in the battery case.
- Batteries with the same shape may have different voltages. Do not use different batteries together.

- When disposing of used batteries, please comply with governmental regulations or environmental public instruction's rules that apply in your country or area.

Operating range of remote control unit

The remote control may not work properly if:

- There are obstacles between the remote control and the receiver's remote sensor.
- Direct sunlight or fluorescent light is shining onto the remote sensor.
- The receiver is located near a device that is emitting infrared rays.
- The receiver is operated simultaneously with another infrared remote control unit.

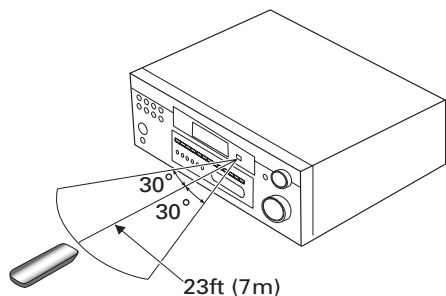

Chapter 2:

5 minute guide

Introduction to home theater

You are probably used to using stereo equipment to listen to music, but may not be used to home theater systems that give you many more options (such as surround sound) when listening to soundtracks.

Home theater refers to the use of multiple audio tracks to create a surround sound effect, making you feel like you're in the middle of the action or concert. The surround sound you get from a home theater system depends not only on the speakers you have set up in your room, but also on the source and the sound settings of the receiver.

DVD-Video has become the basic source material for home theater due to its size, quality, and ease of use. Depending on the DVD, you can have up to seven different audio tracks coming from one disc, all of them being sent to different speakers in your system. This is what creates a surround sound effect and gives you the feeling of 'being there'.

This receiver will automatically decode Dolby Digital, DTS, or Dolby Surround DVD-Video discs, according to your speaker setup. In most cases, you won't have to make changes for realistic surround sound, but other possibilities (like listening to a CD with multi-channel surround sound) are explained in *Listening to your system* on page 35.

Listening to Surround Sound

This receiver was designed with the easiest possible setup in mind, so with the following quick setup guide, you should have your system hooked up for surround sound in no time at all. In most cases, you can simply leave the receiver in the default settings.

Be sure to complete all connections before connecting this unit to the AC power source.

1 Hook up your DVD player.

For surround sound, you'll want to hook up using a digital connection from the DVD player to the receiver. You can do this with either a coaxial, or an optical connection (you don't need to connect both). If you hook up using an optical cable, you should refer to *Digital input settings* on page 47 to assign the optical input to **DVD**.

Use a video cord to connect the video output on your DVD player to the receiver using the jacks shown below.

2 Hook up your TV.

Use a video cord to connect your receiver to the TV using the jacks as shown below.

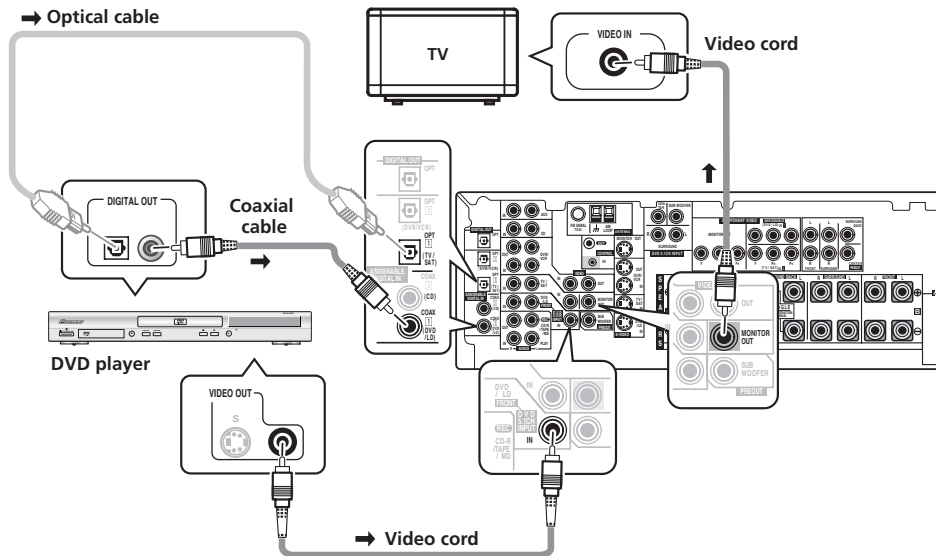

3 Connect your speakers.

A complete setup of eight speakers (including the subwoofer) is shown here but everyone's home setup will vary. Simply connect the speakers you have in the manner shown below. The receiver will work with just two stereo speakers (the front speakers in the diagram) but using at least three speakers is recommended, and a complete setup is best.

Make sure you connect the speaker on the right to the right terminal and the speaker on the left to the left terminal. Also make sure the positive and negative (+/-) terminals on the receiver match those on the speakers. You can use speakers with a nominal impedance between 6–16Ω (please see *Switching the speaker impedance* on page 67 if you plan to use speakers with an impedance of less than 8Ω).

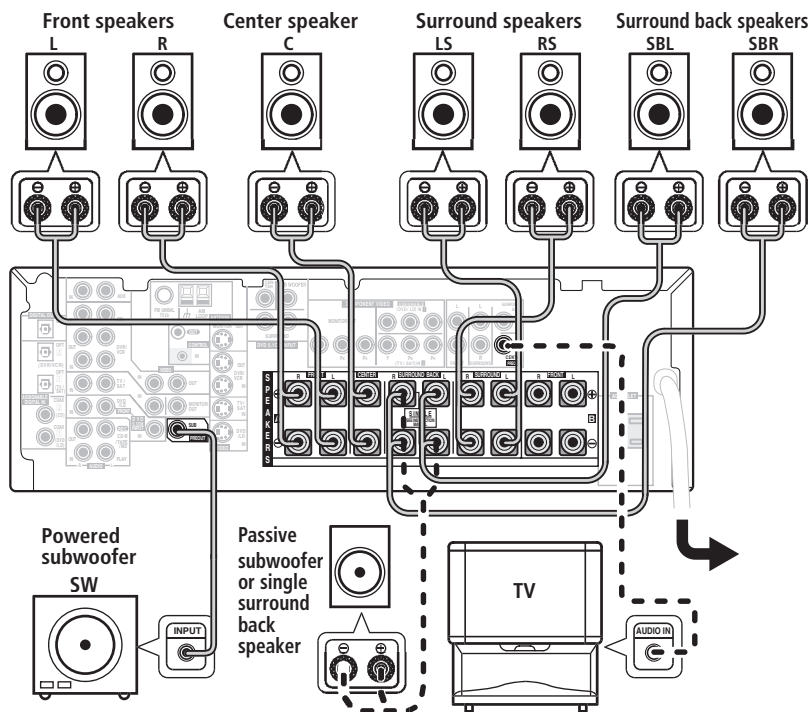

- If you're not using a subwoofer, change the front speaker setting (see *Speaker setting* on page 43) to large.
- To use the speaker on your TV as the center speaker (C), connect the **CENTER PREOUT** jack on this unit to the audio input jack on your TV. In this case the center SBL speaker shown is unnecessary.
- If you are using only one surround back speaker, connect the positive wire to the right channel (+) terminal, and the negative wire to the left channel (-) terminal (shown below).

- If you select subwoofer (**SB SW**) in the *Surround back speaker* setting on page 44 you can hook up a subwoofer instead of speakers to the surround back speaker terminals. Connect the wires just as above (and as shown below), connecting the positive wire to the right channel (+) terminal, and the negative wire to the left channel (–) terminal.

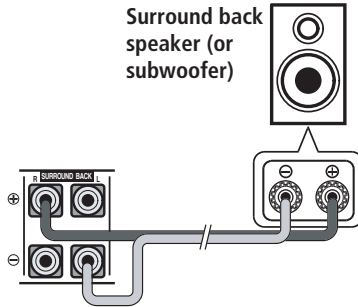

4 Plug in the receiver and switch it on, followed by your DVD player, your subwoofer and the TV.

Make sure you've set the video input on your TV to this receiver. Check the manual that came with the TV if you don't know how to do this.

Also make sure that **DVD/LD** is showing in the receiver's display, indicating that the DVD input is selected. If it isn't, press **DVD** on the remote control to set the receiver to the DVD input.

5 Press QUICK SETUP on the front panel to specify your speaker setup, room size and listening position.

Use the **MULTI JOG** dial to select and **ENTER** to confirm your selection. See *Using the Quick Setup* on page 12 if you're unsure about the settings.

V SX-D914 model only – For a more complete surround sound setup, we recommend using the automatic MCACC setup in the *Quick surround sound setup* on page 14.

6 Play a DVD, and adjust the volume to your liking.

There are several other sound options you can select. See *Listening to your system* on page 35 for more on this. See also *Choosing your receiver setup* on page 42 for more setup options.

Note

- Depending on your DVD player or source discs, you may only get digital 2 channel stereo and analog sound. In this case, the listening mode must be set to **STANDARD** (it should already be set—see *Listening in surround sound* on page 35 if you need to do this) if you want multi-channel surround sound.

Using the Quick Setup

You can use the Quick Setup to get your system up and running with just a few button presses. The receiver automatically makes the necessary settings after you have selected your speaker setup, room size and listening position.

If you want to make more specific settings, refer to *Choosing your receiver setup* on page 42.

Use the front panel controls for the steps below.

VSX-D914 model only – Note that you don't have to make these settings if you use the automatic MCACC setup instead (in this case, go straight to the *Quick surround sound setup* on page 14).

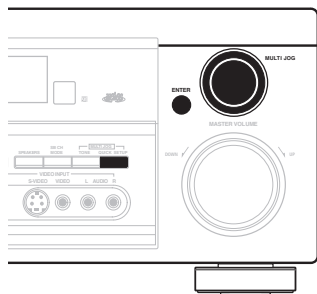

1 If the receiver is off, press **STANDBY/ON** to turn the power on.

2 Press **QUICK SETUP**.

SW DET flashes in the display while the receiver checks your setup for a subwoofer.

SW YES or **SW NO** confirms the subwoofer check, then the display prompts you to select your speaker setup.

3 Use the **MULTI JOG** dial to choose your speaker setup.

When a subwoofer was detected in step 2, you can cycle between the following choices:

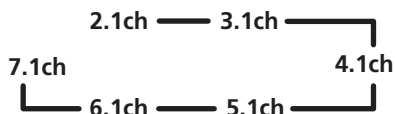

If a subwoofer wasn't detected in step 2, you can cycle between the following choices:

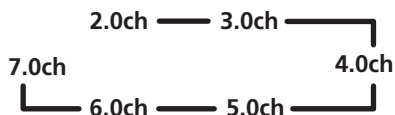

- Check the table below to find the speaker setup that corresponds with your system.

	Front Speakers	Center Speaker	Surround Speakers	Surround Back Sp.	Sub Woofer
2.0 ch	✓				
2.1 ch	✓				✓
3.0 ch	✓	✓			
3.1 ch	✓	✓			✓
4.0 ch	✓		✓		
4.1 ch	✓		✓		✓
5.0 ch	✓	✓	✓		
5.1 ch	✓	✓	✓		✓
6.0 ch	✓	✓	✓	(1 speaker)	
6.1 ch	✓	✓	✓	(1 speaker)	✓
7.0 ch	✓	✓	✓	(2 speakers)	
7.1 ch	✓	✓	✓	(2 speakers)	✓

4 Press **ENTER**.

5 Use the **MULTI JOG** dial to choose your room size.

Depending on the distance of your speakers from the listening position, choose between small, medium, or large (**S**, **M** or **L**), **M** being an average-sized room.

6 Press ENTER.

7 Use the MULTI JOG dial to choose your listening position.

You can cycle between the following choices:

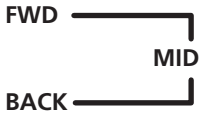

FWD – If you are nearer to the front speakers than the surround speakers

MID – If you are equal distance from the front and surround speakers

BACK – If you are nearer to the surround speakers than the front speakers

8 Press ENTER to confirm your setup.

The display shows the speaker setup, room size and listening position that you have selected.

Chapter 3:

Quick surround sound setup

VSX-D914 model only

Automatically calibrating your listening area (MCACC)

The Multi-Channel Acoustic Calibration (MCACC) system measures the acoustic characteristics of your listening area, taking into account ambient noise, speaker size and distance, and tests for both channel delay and channel level. After you have set up the microphone provided with your system, the receiver uses the information from a series of test tones to optimize the speaker settings and equalization for your particular room.



Caution

- These test tones can be loud, so take care that there is no one in the room who will be startled by the noise.

- Make sure the mic and speakers are not moved during the MCACC setup.

1 Connect the microphone to the MCACC SETUP MIC jack on the front panel.

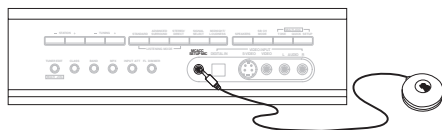

2 Place the microphone at your normal listening position.

Place the mic about ear level at your normal listening position using the supplied microphone stand on a table or chair.

Make sure there are no obstacles between the speakers and the microphone.

3 If the receiver is off, press STANDBY/ON to turn the power on.

4 If you have a subwoofer, turn it on.

5 Press RECEIVER.

6 Press MCACC SETUP.

Try to be as quiet as possible after pressing **MCACC SETUP**. The system outputs a series of test tones to establish the ambient noise level.

If the noise level is too high, **NOISY!** blinks in the display for five seconds. To exit and check the noise levels again, press **MCACC SETUP** (see the notes regarding ambient noise levels below) or press **ENTER** when you're prompted to **GO NEXT?**

The system now checks the microphone and your speaker setup.

If you see an **ERR** message in the display, there may be a problem with your mic or the speaker connections.

Turn off the power, and check the problem indicated by the **ERR** message (see below), then try the auto surround setup again.

- **ERR MIC** – Check the microphone connection.
- **ERR Fch** – Check the front speaker connections.
- **ERR Sch** – Check the surround or surround back speaker connections.
- **ERR SW** – Make sure the subwoofer has been switched on and volume on the subwoofer is turned up.

7 Use \uparrow and \downarrow to select the speaker system that corresponds to your setup.

Cycle through the following choices:

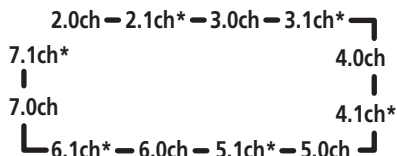

* Indicates a subwoofer is included in your speaker setup

See the table on page 12 if you're unsure which speaker system to select.

8 If you selected a speaker system that includes a subwoofer, press ENTER to check the subwoofer output level.

If the subwoofer output level is too high/low, **SW.VOL.DWN/SW.VOL.UP** blinks in the display for five seconds. To exit and check your subwoofer output level, press **MCACC SETUP** (see the notes regarding noise levels below) or simply press **ENTER** when you're prompted to **GO NEXT?**

9 Press ENTER to finish the auto surround setup.

The system checks for speaker size, channel delay and channel level. If you have connected a subwoofer, it will check for ambient noise once again.

When the auto surround setup is complete, the volume level returns to normal and **COMPLETE**, then **RESUME** shows in the display. The MCACC indicator then lights to show that MCACC setup is complete.



Note

- If the room environment is not optimal for the auto surround setup (too much ambient noise, echo off the walls, obstacles blocking the speakers from the microphone) the final settings may be incorrect. Check for household appliances (air conditioner, fridge, fan, etc.), that may be affecting the environment and switch them off if necessary.
- Some older TVs may interfere with the operation of the mic. If this seems to be happening, switch off the TV when doing the auto surround setup.
- Using the MCACC system to set up your speaker system overwrites any previous settings you had for the **STANDARD** or **ADVANCED SURROUND** modes.
- When the **STANDARD** or **ADVANCED SURROUND** mode is selected, you can check the settings made with MCACC by using **CH SELECT** (to check channel levels) or by going through the steps in *Choosing your receiver setup* on page 42 to check other settings.
- Depending on the characteristics of your room, sometimes identical speakers with cone sizes of around 5 inches (12cm) will end up with different size settings. You can correct the setting manually using the receiver setup on page 42.

Chapter 4: Connecting up



Important

- Before making or changing any connections, switch off the power and disconnect the power cord from the AC outlet.

Audio/Video cords

Use audio/video cords (not supplied) to connect the audio/video components and a video cord to connect the monitor TV.

Connect red plugs to R (right), white plugs to L (left), and the yellow plugs to **VIDEO**.

Be sure to insert completely.

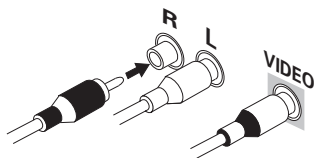

S-video cables

Use S-video cables (not supplied) to get clearer picture reproduction than regular video cords.

Connect from an S-video jack on the rear of the receiver to an S-video jack on the video component you are hooking up.

Be sure to insert completely.

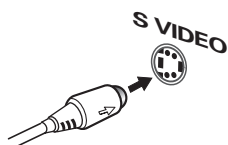

Component video cords

Use component video cords to get the best possible color reproduction of your video source. The color signal of the TV is divided into the luminance (**Y**) signal and the color (**PB** and **PR**) signals and then output. In this way, interference between the signals is avoided. Connect from the component video jacks on the rear of the receiver to the component video jacks on the video component you are hooking up.

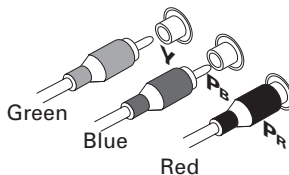

Digital audio coaxial cords/ Optical cables

Commercially available digital audio coaxial cords (standard video cords can also be used) or optical cables (not supplied) are used to connect digital components to this receiver.

Be sure to insert completely.

Digital audio coaxial cord (or standard video cord)

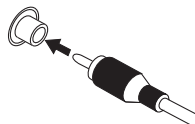

Optical cable

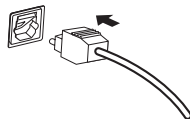

Connecting digital components

The easiest way to hook up this receiver for surround sound is to use a digital input. You can do this by either coaxial or optical connections (you do not need to do both). The quality of these two types of connections is the same but since some digital components only have one type of digital terminal, it is a matter of matching like with like (for example, the coaxial output from the component to coaxial input on the receiver). This receiver has four digital inputs (two coaxial inputs and two optical inputs) on the rear panel. Connect your digital components as shown below.

There is one digital output jack which is marked **DIGITAL OUT**. If you connect this to the optical input on a digital recorder (for example an MD, DAT or CD-R) you can make direct digital recordings with this unit.

When connecting your equipment, always make sure the power is turned off and the power cord is disconnected from the AC outlet.

- The arrows indicate the direction of the signal.

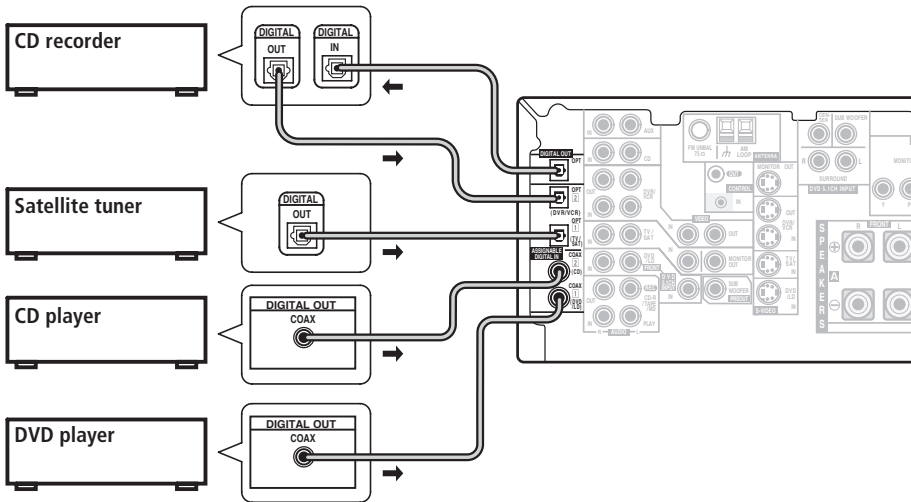

 **Note**

- If you have an LD player, you need to make special connections to ensure you can play **RF** format LDs on your system. If this is the case, hook up your DVD or LD player directly to an RF demodulator using both the **RF** output and either a coaxial or optical digital connection. We also recommend hooking up your digital components to analog audio jacks as well. Make sure the RF demodulator digital in switch is set correctly (optical or coaxial depending on the connection). See the component's instruction manual if you are unsure about its input and output jacks.

Connecting audio components

To begin set up, connect your analog audio components (such as a cassette deck) to the jacks. For components you want to record with, you need to hook up four plugs to the receiver (a set of stereo inputs and a set of stereo outputs), but for components that only play, you only need to hook up one set of stereo plugs. You must also hook up your digital components to analog audio jacks if you want to record to/from digital components (like an MD) to/from analog components. See page 17 for more on digital connections.

When connecting your equipment, always make sure the power is turned off and the power cord is disconnected from the AC outlet.

- The arrows indicate the direction of the audio signal.

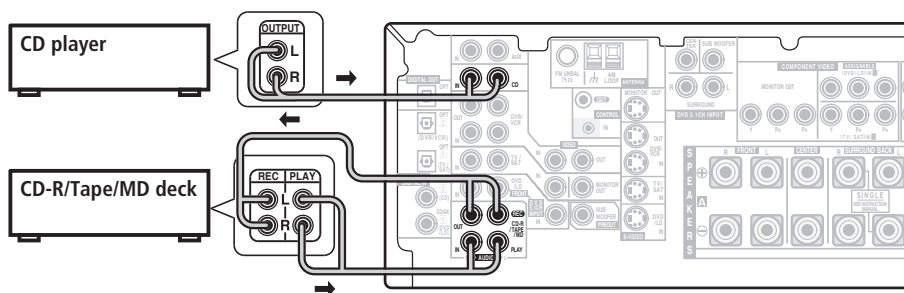

Connecting DVD 5.1 channel components

If you prefer to use a separate component for decoding DVDs, you can connect a decoder or a DVD player with multi-channel analog outputs to the multi-channel inputs of this receiver. Note that the multi-channel input can only be used when **DVD 5.1 ch** is selected (see page 41).

When connecting your equipment, always make sure the power is turned off and the power cord is disconnected from the AC outlet.

- The arrows indicate the direction of the signal.

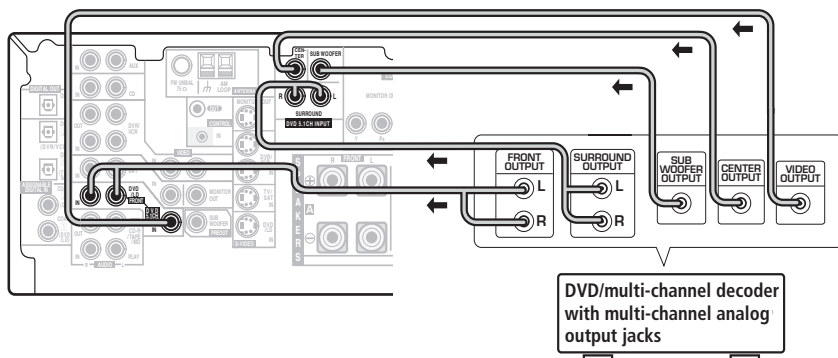

Connecting video components

Connect your video components to the jacks as shown below. With digital video components (like a DVD player), you must use the connections shown on this page for the video signal, but in order to hear a digital source (like a DVD) you should hook up the audio to a digital input (see page 17). It is also a good idea to hook up your digital components with analog audio connections (see page 18).

For better quality video, you can hook up using the component video jacks or the S-video jacks (quality descends in this order) on the rear of the receiver instead of the regular video jacks. Make sure they are connected to the video component using the same kind of connection.

When connecting your equipment, always make sure the power is turned off and the power cord is disconnected from the AC outlet.

- The arrows indicate the direction of the signal

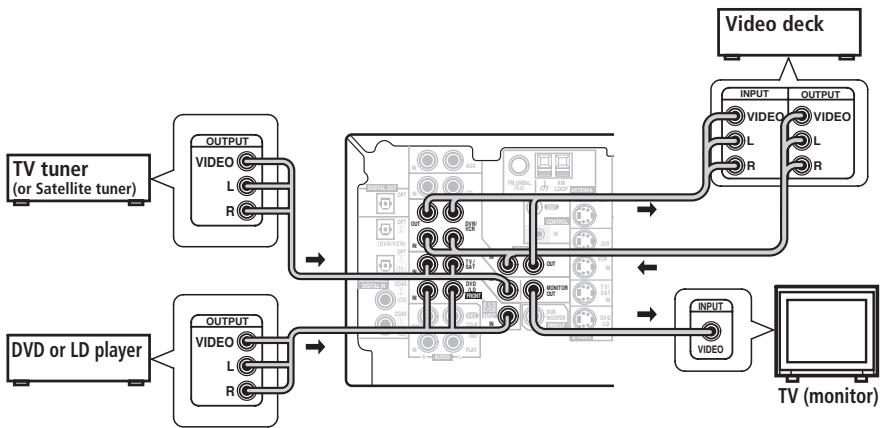

Connecting to the front panel video terminal

Front video connections are accessed via the front panel using the **VIDEO** button. There are standard audio/video jacks as well as an S-video jack and an optical input. Hook them up the same way you made the rear panel connections.

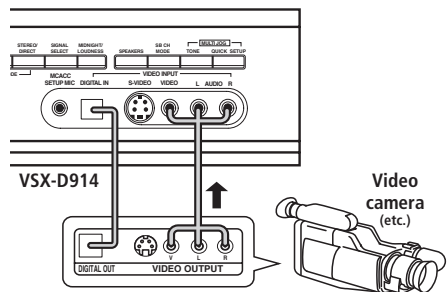

Connecting antennas

Connect the AM loop antenna and the FM wire antenna as shown below. To improve reception and sound quality, connect external antennas (see *Using external antennas* below). Always make sure that the receiver is switched off and unplugged from the wall outlet before making or changing any connections.

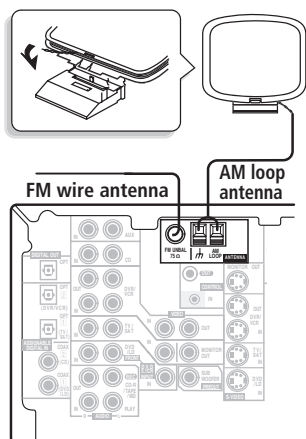

FM wire antenna

Connect the FM wire antenna and fully extend vertically along a window frame or another suitable place that gives good reception.

AM loop antenna

Assemble the antenna and connect to the receiver. Attach (if necessary) and face in the direction that gives the best reception.

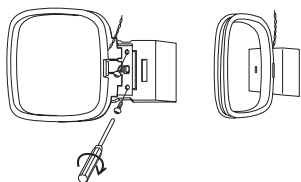

Antenna snap connectors

Twist the exposed wire strands together and insert into the hole, then snap the connector shut.

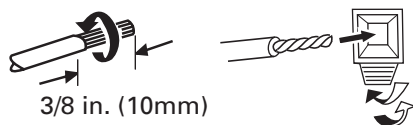

Using external antennas

To improve FM reception

Use an F connector to connect an external FM antenna.

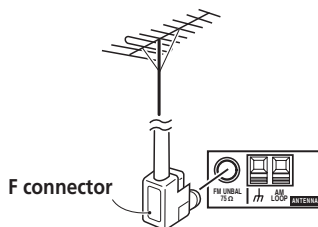

To improve AM reception

Connect a 15–18 feet length of vinyl-coated wire to the AM antenna terminal without disconnecting the supplied AM loop antenna. For the best possible reception, suspend horizontally outdoors.

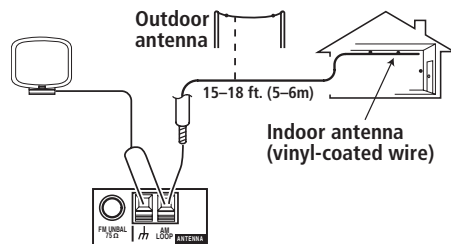

Connecting the speakers

A complete setup of eight speakers (including the subwoofer) is shown below, but everyone's home setup will vary. Simply connect the speakers you have in the manner shown below. The receiver will work with just two stereo speakers (the front speakers in the diagram) but using at least three speakers is recommended, and a complete setup is best for surround sound. If you're not using a subwoofer, change the front speaker setting (see *Speaker setting* on page 43) to large.

Make sure you connect the speaker on the right to the right terminal and the speaker on the left to the left terminal. Also make sure the positive and negative (+/-) terminals on the receiver match those on the speakers. You can use speakers with a nominal impedance between 6–16Ω (please see *Switching the speaker impedance* on page 67 if you plan to use speakers with an impedance of less than 8Ω).

Be sure to complete all connections before connecting this unit to the AC power source.

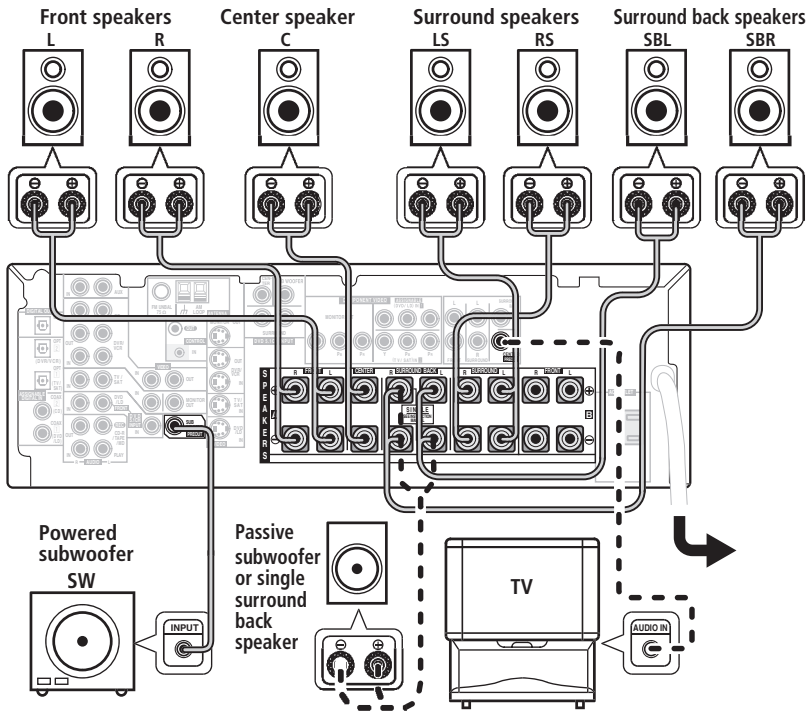

**Note**

- When using the speaker on your TV as the center speaker (**C**), connect the **CENTER PREOUT** jack on this unit to the audio input jack on your TV. In this case the center speaker shown is unnecessary.
- If you are using only one surround back speaker, connect the positive wire to the right channel (+) terminal, and the negative wire to the left channel (-) terminal (see illustration on page 10).
- If you select subwoofer (**SB SW**) in the *Surround back speaker* setting on page 44 you can hook up a subwoofer instead of speakers to the surround back speaker terminals. Connect the positive wire to the right channel (+) terminal, and the negative wire to the left channel (-) terminal (see illustration on page 11).

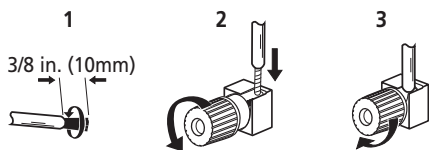
Speaker terminals

1 Twist exposed wire strands together.

2 Loosen speaker terminal and insert exposed wire.

Make sure that all the bare speaker wire is twisted together and inserted fully into the speaker terminal. If any of the bare speaker wire is touching the back panel when you switch the unit on, the power may cut off as a safety measure. Use good quality speaker wire to connect the speakers to the receiver.

3 Tighten terminal.

**Note**

- The speaker terminals also accept single banana plugs. (Refer to speaker manual for details.)

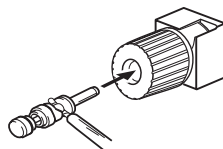
**A and B speaker systems**

The receiver has two speaker systems: A and B. A is the main system supporting the full speaker setup. If you switch on both A and B speaker systems, only the front speakers and the (active) subwoofer will be audible. No sound will come from the center, surround, or surround back speakers, but multi-channel sources will be down-mixed to the active speakers so no sound will be lost. Similarly, if you choose just the B system you'll only hear the front speakers connected to the B system and multi channel sources will be down-mixed to these two speakers.

- **Press the **SPEAKERS** button on the front panel to switch between speaker systems (A, B or both).**

Hints on speaker placement

Speakers are usually designed with a particular placement in mind. Some are designed to be floorstanding, while others should be placed on stands to sound their best. Some should be placed near a wall; others should be placed away from walls. We have provided a few tips on getting the best sound from your speakers (following), but you should also follow the guidelines on placement that the speaker manufacturer provided with your particular speakers to get the most out of them.

- Place the front left and right speakers at equal distances from the TV.
- When placing speakers near the TV, we recommend using magnetically shielded speakers to prevent possible interference, such as discoloration of the picture when the TV is switched on. If you do not have magnetically shielded speakers and notice discoloration of the TV picture, move the speakers farther away from the TV.
- Place the center speaker above or below the TV so that the sound of the center channel is localized at the TV screen.
- If possible, place the surround speakers slightly above ear level.
- Try not to place the surround speakers farther away from the listening position than the front and center speakers. Doing so can weaken the surround sound effect.
- To achieve the best possible surround sound, install your speakers as shown below. Be sure all speakers are installed securely to prevent accidents and improve sound quality.



Caution

- If you choose to install the center speaker on top of the TV, be sure to secure it with putty, or by other suitable means, to reduce the risk of damage or injury resulting from the speaker falling from the TV in the event of external shocks such as earthquakes.
- Make sure no exposed speaker wire is touching the rear panel, this may cause the receiver to turn off automatically.

Overhead view of speaker setup

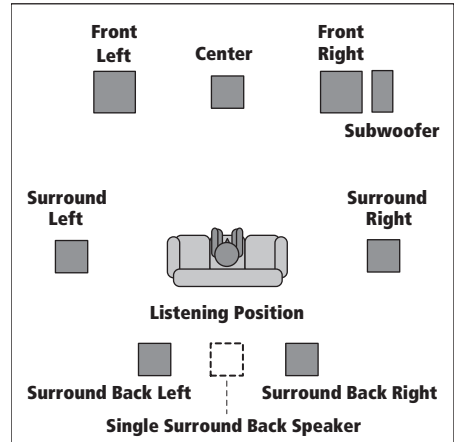

3-D view of 6.1 channel speaker setup



3-D view of 7.1 channel speaker setup



Connecting additional amplifiers

This receiver has more than sufficient power for any home use, however it is possible to add additional amplifiers to every channel on this receiver. Make the connections shown below to add amplifiers to power your speakers. Always make sure that the receiver is switched off and unplugged from the wall outlet before making or changing any connections.

- The arrows indicate the direction of the audio signal.

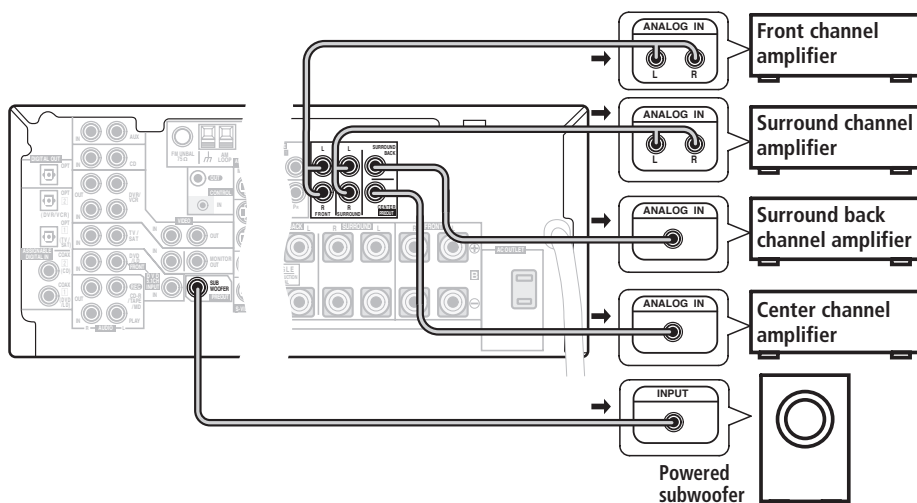

Note

- To hear sound only from the pre-outs, disconnect any speakers that are connected directly to the receiver.
- If you're not using a subwoofer, change the front speaker setting (see *Speaker setting* on page 43) to large.

AC outlet

Power supplied through this outlet is turned on and off by the receiver's power switch. Total electrical power consumption of connected equipment should not exceed 100 W (0.8 A).

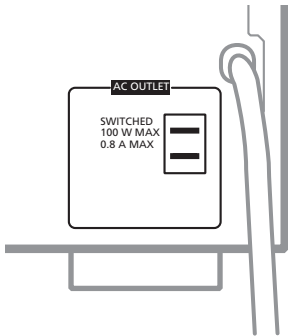

Caution

- Do not connect a monitor, TV set, heater, or similar appliance to this unit's AC outlet.
- Do not connect appliances with high power consumption to the AC outlet in order to avoid overheating and fire risk. This can also cause the receiver to malfunction.



Note

- This unit should be disconnected by removing the power plug from the wall socket when not in regular use (ex. when on vacation).

Power cord caution

Handle the power cord by the plug. Do not pull out the plug by tugging the cord and never touch the power cord when your hands are wet as this could cause a short circuit or an electric shock. Do not place the unit, a piece of furniture, etc., on the power cord, or pinch the cord. Never make a knot in the cord or tie it with other cords. The power cords should be routed such that they are not likely to be stepped on. A damaged power cord can cause a fire or give you an electrical shock. Check the power cord once in a while. When you find it damaged, ask your nearest Pioneer authorized service center or your dealer for a replacement.

Operating other Pioneer components

By connecting a control cord (optional), you can point the remote controls of other Pioneer components at the receiver's remote sensor. The remote control signals are received by the remote sensor of this unit, and sent to the other devices via the **CONTROL OUT** terminal on the receiver.

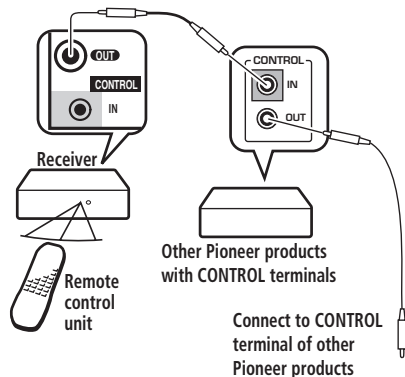

Using this receiver with a Pioneer plasma display

If you have a Pioneer plasma display (models PRO-1110HD, PRO-910HD, PDP-5040HD, PDP-4340HD), you can use an SR+ cable and take advantage of various convenient features, such as automatic video input switching of the plasma display when the input is changed.

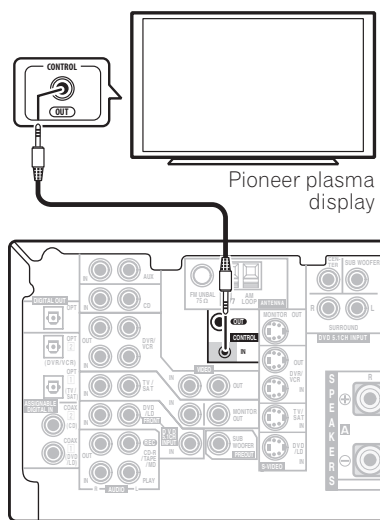

Important

- If you connect to a Pioneer plasma display using an SR+ cable, you will need to point the remote control at the plasma display to control the receiver. In this case, you won't be able to control the receiver using the remote control if you switch the plasma display off.

- Use a 3-ringed miniplug SR+ cable to connect the CONTROL IN jack of this receiver with the CONTROL OUT of your plasma display.

Before you can use the extra SR+ features, you need to make a few settings in the receiver. See *SR+ control for Pioneer plasma displays* on page 48 for detailed instructions.

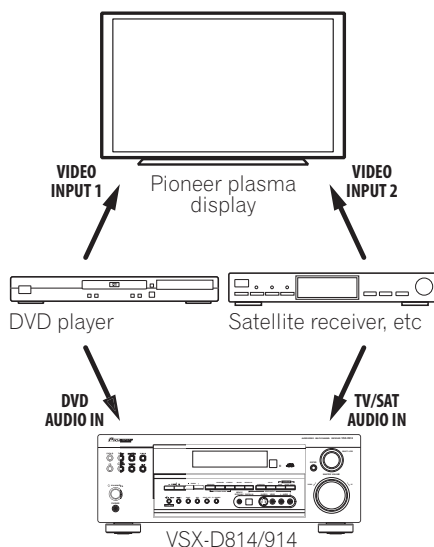

To make the most of the SR+ features, you should connect your source components (DVD player, etc.) in a slightly different way to that described in this chapter. For each component, connect the video output directly to the plasma display, and just connect the audio (analog and/or digital) to this receiver.



Note

- The 3-ringed SR+ cable from Pioneer is commercially available under the part number ADE7095. Contact the Pioneer Customer Support division for more information on obtaining an SR+ cable.

Chapter 5: Controls and displays

Front panel

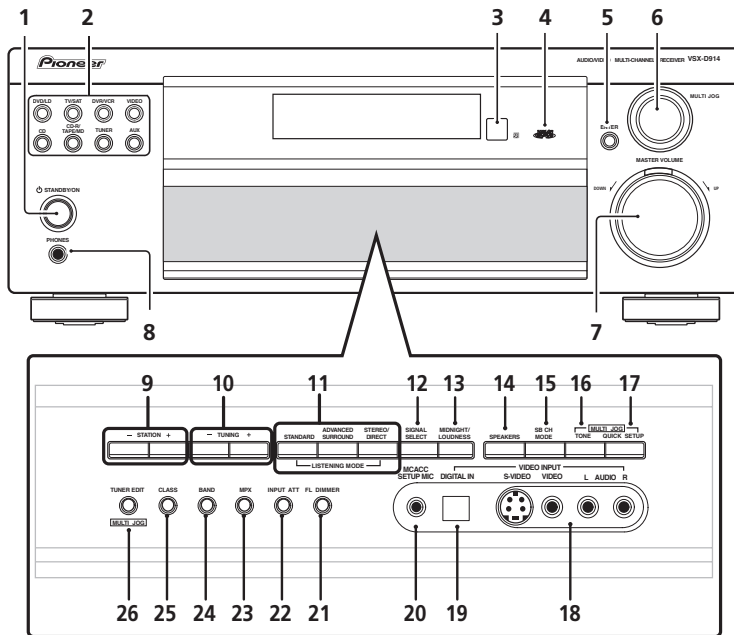

1 **⏻ STANDBY/ON**

Switches the receiver between on and standby.

2 **Input select buttons**

Press to select an input source (selected source button will light).

3 **Remote sensor**

Receives the signals from the remote control.

4 **MCACC indicator**

Lights after MCACC setup (page 49, *VSX-D914 model only* – page 14).

5 **ENTER**

6 **MULTI JOG dial**

The **MULTI JOG** dial performs a number of tasks. Use it to select options after pressing **tone**, **QUICK SETUP** or **TUNER EDIT**.

7 **MASTER VOLUME**

8 **PHONES jack**

Use to connect headphones. When the headphones are connected, there is no sound output from the speakers.

9 STATION +/- buttons

Selects station presets when using the tuner (page 54).

10 TUNING +/- buttons

Selects the frequency when using the tuner (page 53).

11 LISTENING MODE buttons**STANDARD**

Press for Standard decoding and to switch between the various Pro Logic IIx and Neo:6 options (page 35).

ADVANCED SURROUND

Use to switch between the various surround modes (page 35).

STEREO/DIRECT

Switches between direct and stereo playback. Direct playback bypasses the tone controls and channel levels for the most accurate reproduction of a source (page 36).

12 SIGNAL SELECT

Use to select an input signal (page 37).

13 MIDNIGHT/LOUDNESS

Use Midnight when listening to movie soundtracks at low volume. Use Loudness to boost the bass and treble at low volume (page 40).

14 SPEAKERS

Use to cycle through the speaker system: **A → B → A+B** (page 22). Also used to change the speaker impedance (*Switching the speaker impedance* on page 67).

15 SB CH MODE

Selects the Surround back channel mode (page 38).

16 TONE

Press this button to access the bass and treble controls, which you can then adjust with the **MULTI JOG** dial.

17 QUICK SETUP

See *Using the Quick Setup* on page 12.

18 VIDEO INPUT

See *Connecting to the front panel video terminal* on page 19.

19 DIGITAL IN

See *Connecting to the front panel video terminal* on page 19.

20 MCACC SETUP MIC

(V SX-D914 model only)

Connect the microphone supplied with your system to the **MCACC SETUP MIC** jack when using the auto surround setup (MCACC) (page 14).

21 FL DIMMER

Use this button to make the fluorescent display (FL) dimmer or brighter.

22 INPUT ATT

Use to attenuate (lower) the level of an analog input signal to prevent distortion.

23 MPX

Press to receive a radio broadcast in mono (page 53).

24 BAND

Switches between AM and FM radio bands (page 53).

25 CLASS

Switches between the three banks (classes) of station presets (page 54).

26 TUNER EDIT

Press to memorize and name a station for recall (page 54).

Display

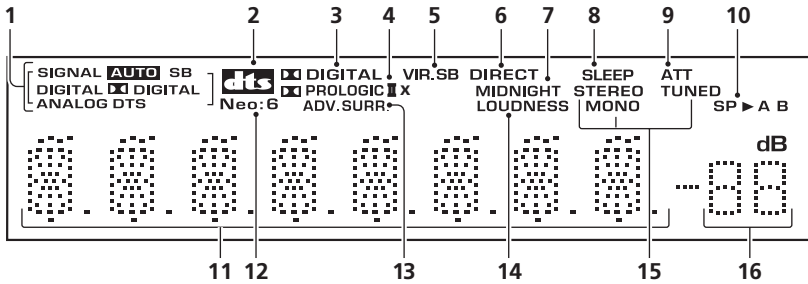

1 SIGNAL SELECT indicators

Lights to indicate the type of input signal assigned for the current component:

AUTO

Lights when **AUTO** signal select is on.

SB

Depending on the source, this lights when a signal with surround back channel encoding is detected.

DIGITAL

Lights when a digital audio signal is detected.

DIGITAL

Lights when a Dolby Digital encoded signal is detected.

ANALOG

Lights when an analog signal is detected.

DTS

Lights when a source with DTS encoded audio signals is detected.

2

When the **STANDARD** mode of the receiver is on, this lights to indicate decoding of a DTS signal.

3 DIGITAL

When the **STANDARD** mode of the receiver is on, this lights to indicate decoding of a Dolby Digital signal.

4 PRO LOGIC II (x)

When the (**STANDARD**) Pro Logic II mode of the receiver is on, this lights to indicate Pro Logic II decoding. The **x** lights to indicate Pro Logic IIx decoding (see *Listening in surround sound* on page 35 for more on this).

5 VIR.SB

Lights during Virtual surround back processing.

6 DIRECT

Lights when source direct playback is selected. Direct playback bypasses the tone controls and channel levels for the most accurate reproduction of a source.

7 MIDNIGHT

Lights during Midnight listening.

8 SLEEP

Lights when the receiver is in sleep mode.

9 ATT

Lights when **INPUT ATT** is used to attenuate (reduce) the level of the analog input signal.

10 Speaker indicator

Shows the speaker system currently in use.

11 Character display

12 Neo:6

When the (**STANDARD**) NEO:6 mode of the receiver is on, this lights to indicate NEO:6 processing.

13 ADV.SURR. (Advanced Surround)

Lights when one of the Advanced Surround modes has been selected.

14 LOUDNESS

Lights when **LOUDNESS** has been selected.

15 TUNER indicators

STEREO

Lights when a stereo FM broadcast is being received in auto stereo mode.

MONO

Lights when the mono mode is set using the **MPX** button.

TUNED

Lights when a broadcast is being received.

16 Master volume level

Shows the overall volume level. **---dB** indicates the minimum level, and **- 0 dB** indicates the maximum level.

Depending on your level settings for each channel, the maximum volume can range between -10 dB and -0 dB.

Remote control

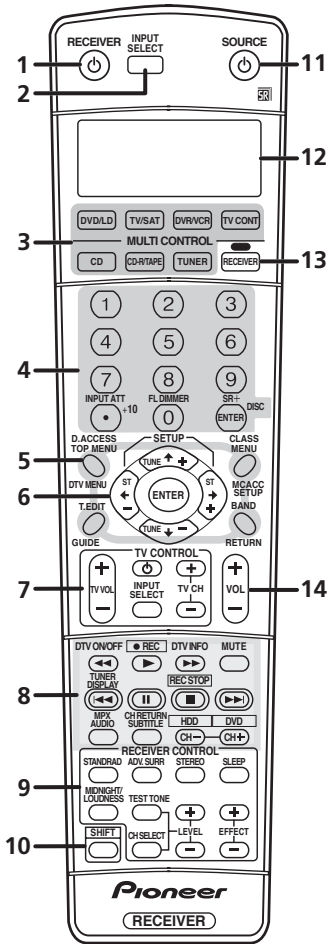

1 RECEIVER

This switches between standby and on for this receiver.

2 INPUT SELECT

Use to select the input source.

3 MULTI CONTROL buttons

Press to select control of other components (see *Controlling the rest of your system* on page 57).

4 Number buttons and other receiver/ component controls

Use the number buttons to directly select a radio frequency (page 53) or the tracks on a CD, DVD, etc.

DISC (ENTER) can be used to enter commands for TV or DTV, and can also be used to select a disc in a multi-CD player.

The following are accessed by pressing the **RECEIVER** button first:

INPUT ATT

Attenuates (lowers) the level of an analog input signal to prevent distortion.

FL DIMMER

Dims or brightens the display.

SR+

Switches the SR+ mode on/off.

5 Tuner/component control buttons/ MCACC

The following button controls (except **MCACC SETUP**) can be accessed after you have selected the corresponding **MULTI CONTROL** button (**TUNER**, **DVD**, **TV/SAT**, etc.).

D. ACCESS

After pressing, you can access a radio station directly using the number buttons (page 53).

TOP MENU

Displays the disc 'top' menu of a DVD.

DTV MENU

Displays menus on a digital TV.

T. EDIT

Press to memorize and name a station for recall (page 54).

GUIDE

Displays the guides on a digital TV.

CLASS

Switches between the three banks (classes) of radio station presets (page 54).

MENU

Displays the disc menu of DVD-Video discs. It also displays TV and DTV menus.

MCACC SETUP

(Press **RECEIVER** first to access)

Use to setup your speaker system using Multi-Channel Acoustic Calibration (MCACC) (page 49, *VSX-D914 model only* – page 14).

BAND

Switches between the tuner AM and FM bands (page 53).

RETURN

Press to return to the previous menu with DVDs or to select closed captioning with DTV.

6 ⇐⇒ ↓↑ (**TUNE/ST +/-**) /**ENTER**

Use the arrow buttons when setting up your surround sound system (see page 42). Also used to control DVD menus/options and for deck 1 of a double cassette deck player. Use the **TUNE +/-** buttons to find radio frequencies and use **ST +/-** to find preset stations (page 54).

7 TV CONTROL buttons

These buttons are dedicated to control the TV assigned to the **TV CONT** button. Thus if you only have one TV to hook up to this system assign it to the **TV CONT MULTI CONTROL** button. If you have two TVs, assign the main TV to the **TV CONT** button.

TV

Use to turn on/off the power of the TV.

TV VOL +/-

Use to adjust the volume on your TV.

INPUT SELECT

Use to select the TV function.

TV CH +/-

Use to select channels.

8 Component control buttons

The main buttons (▶, ■, etc.) are used to control a component after you have selected it using the **MULTI CONTROL** buttons.

The controls above these buttons can be accessed after you have selected the corresponding **MULTI CONTROL** button (for example **DVD/LD**, **DVR/VCR** or **TV/SAT** (when connected to a DTV)).

DTV ON/OFF

Switches a digital TV on/off.

DTV INFO

Use to bring up information screens on a digital TV.

MUTE

Mutes the sound (or restores the sound if it has been muted).

TUNER DISPLAY

Displays TV information on-screen.

MPX (Press **TUNER** first to access)

Switches between stereo and mono reception of FM broadcasts. If the signal is weak then switching to mono will improve the sound quality (page 53).

AUDIO

Changes the audio language or channel on DVD discs.

CH RETURN

Returns to the last channel selected with DTV, SAT and some TVs.

SUBTITLE

Displays/changes the subtitles included in multilingual DVD-Video discs.

CH +/-

Use to select channels when using a TV, VCR, DVR, etc.

The following DVR controls can be accessed by pressing **SHIFT**:

● **REC**

Starts recording.

REC STOP

Stops recording.

HDD/DVD

These buttons switch between the hard disk and DVD controls for DVD/HDD recorders.

9 RECEIVER CONTROL buttons

STANDARD

Press for Standard decoding and to switch between the various Pro Logic IIx and Neo:6 options (page 35).

ADV. SURR.

Use to switch between the various surround modes (page 35).

STEREO

Switches between direct and stereo playback. Direct playback bypasses the tone controls and channel levels for the most accurate reproduction of a source (page 36).

SLEEP

Use to put the receiver in sleep mode and select the amount of time before the receiver turns off (page 41).

MIDNIGHT/LOUDNESS

Switches to Midnight or Loudness listening (page 40).

TEST TONE

Sounds the test tone when setting up the surround sound of the receiver (page 50).

CH SELECT

Selects a speaker when setting up the surround sound of the receiver (page 50).

LEVEL +/-

Adjusts the levels of the surround sound of the receiver (page 50).

EFFECT +/-

Adds or subtracts the amount of effect with different advanced surround modes (page 35).

10 SHIFT

Press to access the DVR controls above the component control buttons.

11 SOURCE

Press to turn on/off other components connected to the receiver.

12 Character display (LCD)

This display shows preset codes and other information when transmitting control signals.

The following commands are shown when you're setting the remote to control other components (see *Controlling the rest of your system* on page 57):

SETUP

Indicates the setup mode, from which you choose the options below.

PRESET

See *Selecting preset codes directly* on page 57.

LEARN (VSX-D914 model only)

See *Programming signals from other remote controls* on page 58.

DIRECT F

See *Direct function* on page 60.

ERASE (VSX-D914 model only)

See *Erasing one of the remote control button settings* on page 59.

RESET

See *Erasing all of the remote control presets* on page 60.

READ ID

See *Confirming preset codes* on page 60.

13 RECEIVER

Switches the remote to control the receiver (used to select the features above the number buttons (**INPUT ATT**, etc). Also use this button to set up surround sound (page 42, page 49, page 50).

14 MASTER VOLUME +/-

Use to set the listening volume.

Chapter 6:

Listening to your system

Listening in surround sound

Using this receiver, you can listen to any source in surround sound. However, the options available will depend on your speaker setup and the type of source you're listening to.

If you connected surround back speakers, see also *Using the Surround Back Channel (SB CH)* on page 38.

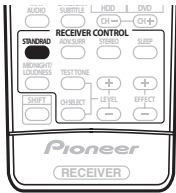

- While listening to a source, press **STANDARD**.

If the source is Dolby Digital, DTS, or Dolby Surround encoded, the proper decoding format will automatically be selected and shows in the display.

With two channel sources, press **STANDARD** repeatedly to select from:

- **Pro Logic IIx MOVIE** – Up to 6.1 channel sound, especially suited to movie sources
- **Pro Logic IIx MUSIC** – Up to 6.1 channel sound, especially suited to music sources
- **PRO LOGIC** – 4.1 channel surround sound (sound from the surround speakers is mono)
- **NEO:6 CINEMA** – 6.1 channel sound, especially suited to movie sources

- **NEO:6 MUSIC** – 6.1 channel sound, especially suited to music sources



Note

- You can't use the **STANDARD** mode with 96kHz PCM or DTS 96kHz/24-bit stereo sources.
- During playback of a Dolby Digital multi-channel source with the **SB CH MODE** switched **ON**, you will only be able to select **DOLBY EX** or **Pro Logic IIx MUSIC**. See *Using the Surround Back Channel (SB CH)* on page 38 for more on this.

Using the Advanced surround effects

The Advanced surround effects can be used for a variety of additional surround sound effects. Most Advanced Surround modes are designed to be used with film soundtracks, but some modes are also suited for music sources. Try different settings with various soundtracks to see which you like.

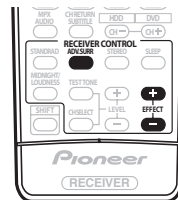

- Press **ADV. SURR. (ADVANCED SURROUND)** repeatedly to select a listening mode.

- **ADV. MOVIE** – Simulates the relaxed environment of a movie theater, and is suitable for watching movies.

- **ADV. MUSIC** – Simulates the acoustic environment of a large concert hall and is suitable for music or musical sources.
- **TV SURR.** – This mode produces surround sound for both mono and stereo TV sources. It is useful for older movies recorded with mono soundtracks.
- **SPORTS** – This is designed for sports programs with a lot of action, adding to the excitement by bringing background action to the forefront.
- **GAME** – Useful when playing video games. It works especially well with sound moving from left to right in game software with a lot of movement.
- **EXPANDED** – This mode is especially designed to give sound depth to stereo sources, and lets you hear two-channel (stereo) signals as simulated multi-channel surround sound. Use with Dolby Pro Logic for a stereo surround effect. You can also use with Dolby Digital sources for a wider stereo field than the Standard modes.
- **6-STEREO** – This can be selected to give multi-channel sound to a stereo source, using all of the speakers in your setup.
- **PHONES SURROUND** – When listening through headphones, you can still get the effect of overall surround.



Note

- Depending on the source and the sound mode you have selected, you may not get sound from the surround back speakers in your setup. For more on this, refer to *Using the Surround Back Channel (SB CH)* on page 38.
- If you press **ADV. SURR.** when the headphones are connected, the **PHONES SURROUND** mode will automatically be selected.

- You can't use the Advanced Surround listening modes with 96kHz PCM or DTS 96kHz/24 bit sources.



Tip

- The Advanced Surround effects can be adjusted in the range of 10 to 90 by pressing **EFFECT +/-**. The effect level can be set for each Advanced Surround mode. The Standard mode cannot be changed.

Listening in stereo

When you select **STEREO** or **DIRECT**, you will hear the source through just the front left and right speakers (and possibly your subwoofer depending on your speaker settings). Dolby Digital and DTS multichannel sources are downmixed to stereo.

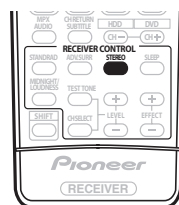

- **While listening to a source, press STEREO for stereo playback.**

Press repeatedly to switch between:

- **STEREO** – The audio is heard with your surround settings and you can still use the Midnight, Loudness, and Tone control functions.
- **DIRECT** – Bypass all effects and surround settings so that the audio remains as close to the source audio signal as possible.

 **Note**

- If you switch on Midnight listening, Loudness, or the Tone controls when **DIRECT** is selected, the receiver automatically switches to **STEREO**.

Choosing the input signal

- Default setting: **AUTO**

You need to hook up a component to both analog and digital inputs on the rear of the receiver to select between input signals.

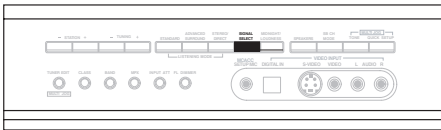

- **Press SIGNAL SELECT on the front panel to select the input signal corresponding to the source component.**

Each press cycles through the options as follows:

- **AUTO** – This automatically switches to **DIGITAL** if a digital source is detected, otherwise it remains on **ANALOG**.
- **DVD 5.1ch** – Selects the multichannel inputs (only appears when **DVD/LD** is selected).
- **ANALOG** – Selects the analog inputs.
- **DIGITAL** – Selects the digital input.

When set to **DIGITAL** or **AUTO**, **DD DIGITAL** lights when a Dolby Digital signal is input, and **DTS** lights when a DTS signal is input.

 **Note**

- This receiver can only play back Dolby Digital, PCM (32kHz–96 kHz) and DTS digital signal formats (including DTS 96kHz/24 bit). With other digital signal formats, set to **ANALOG**.

- You may get digital noise when a LD or CD player compatible with DTS is playing an analog signal. To prevent noise, make the proper digital connections (page 17) and set the signal input to **DIGITAL**.
- Some DVD players don't output DTS signals. For more details, refer to the instruction manual supplied with your DVD player.

Using the Surround Back Channel (SB CH)

- Default setting: **SB ON**

You can have the receiver automatically switch to Dolby Digital EX or DTS-ES decoding for 6.1 encoded sources (**SB AUTO**), or you can choose to listen to other kinds of sources (for example, 5.1 encoded material) with 6.1 encoding (**SB ON**). With 5.1 encoded sources, a surround back channel will be generated, but the material may sound better in the 5.1 format for which it was originally encoded, in which case you can simply switch the surround back channel off (**SB OFF**).

The table indicates when you will hear the surround back channel.

- Press **SB CH MODE** (front panel) repeatedly to cycle the surround back channel options.

Each press cycles through the options as follows:

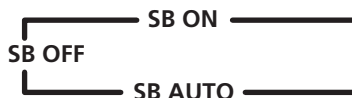

Note

- You can't use the surround back channel with headphones, the **STEREO / DIRECT** mode, or if the *Surround back speaker setting* on page 44 is **SB SW** or **SB ✖**.
- You can't hear the surround back channel with DTS 96kHz/24 bit sources.

Type of source	SB CH MODE	STANDARD			ADVANCED SURROUND
		STANDARD decoding	PRO LOGIC IIx MOVIE/MUSIC	NEO:6 CINEMA/ NEO:6 MUSIC	All modes
DTS-ES/Dolby Digital Matrix encoded multi-channel sources with 6.1 surround	ON	✓			✓
	AUTO	✓			✓
Dolby Digital/DTS encoded multi-channel sources	ON	✓	✓ (Dolby Digital)		✓
	AUTO				✓
Dolby Digital/DTS encoded stereo sources, Stereo sources	ON		✓	✓	✓
	AUTO		✓	✓	✓
Analog 2-channel (stereo) source	ON		✓	✓	✓
	AUTO		✓	✓	✓

Using the Virtual Surround Back mode (VSB)

Selecting this mode allows you to hear a virtual back channel through your surround speakers. For example, you can choose to listen to sources with no surround back channel information (for example, 5.1 encoded material) with emulated 6.1 encoding (**VSB ON**). Sometimes the material may sound better in the 5.1 format for which it was originally encoded. In this case you can have the receiver only apply this effect to 6.1 encoded sources like Dolby Digital EX or DTS-ES (**VSB AUTO**), or you can simply switch it off (**VSB OFF**).

The table indicates when you will hear the virtual surround back channel.

• **Press SB CH MODE (front panel) repeatedly to cycle the virtual surround back channel options.**

Each press cycles through the options as follows:



Note

- You can't use the Virtual Surround Back mode with headphones, the **STEREO / DIRECT** mode, or if the *Speaker setting* on page 43 is set to **S***.
- You can only use the Virtual Surround Back mode if the surround speakers are on and the *Surround back speaker setting* on page 44 is set to **SB *** or **SB SW**.
- You can't adjust the surround back channel level when you're listening to the virtual surround back channel.

Type of source	Virtual Surround Back mode	STANDARD			ADVANCED SURROUND
		STANDARD decoding	PRO LOGIC IIx MOVIE/MUSIC	NEO:6 CINEMA/ NEO:6 MUSIC	All modes
DTS-ES/Dolby Digital Matrix encoded multi-channel sources with 6.1 surround	ON	√			√
	AUTO	√			√
Dolby Digital/DTS encoded multi-channel sources	ON	√			√
	AUTO				√
Dolby Digital/DTS encoded stereo sources, Stereo sources	ON		√	√	√
	AUTO			√	√
Analog 2-channel (stereo) source	ON		√	√	√
	AUTO			√	√

Using Loudness and Midnight listening

The Loudness listening feature can be used to get good bass and treble from music sources at low volume levels.

The Midnight listening feature allows you to hear effective surround sound of movies at low volume levels. The effect automatically adjusts according to the volume at which you're listening.

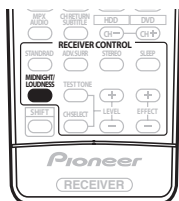

- Press **MIDNIGHT/LOUDNESS** to switch between **MIDNIGHT**, **LOUDNESS**, and **OFF**.

Note

- You can't use **MIDNIGHT/LOUDNESS** when **DVD 5.1 ch** has been selected, or with **DTS 96kHz/24 bit** sources.

Using the tone controls

Depending on what you are listening to, you may want to adjust the bass or treble using the front panel tone control.

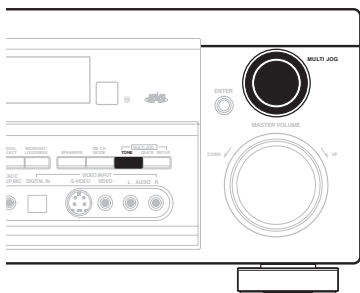

- 1 Press **TONE** to select the frequency you want to adjust.

Each press switches between **BASS** and **TREBLE**.

- 2 Use the **MULTI JOG** dial to change the amount of bass or treble as necessary.

Wait about five seconds for your changes to be input automatically.

Note

- You can only use the tone controls when **STEREO/DIRECT** is selected. **DIRECT** will switch to **STEREO** when the tone controls are used.
- The tone controls affect **SPEAKER A** only. They can't be used when **SPEAKER A** is switched off.

Playing other sources

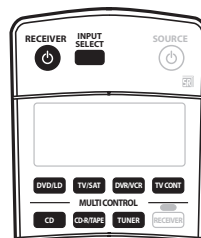

- 1 Turn on the power of the playback component.

- 2 Turn on the power of the receiver.

- 3 Select the source you want to playback.

Use the **MULTI CONTROL** buttons (or **INPUT SELECT**).

- 4 Start playback of the component you selected in step 1.

Selecting the multi-channel analog inputs

If you have connected a decoder or a DVD player with multi-channel analog outputs to this receiver (page 18), you must select the analog multi-channel inputs for surround sound playback.

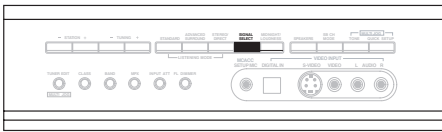

1 Press DVD (DVD/LD on the front panel).

2 Press SIGNAL SELECT on the front panel repeatedly to select DVD 5.1ch.

To cancel playback from the multi-channel inputs, use the **SIGNAL SELECT** button to select a different input signal.

Note

- When playback from the multi-channel inputs is selected, you can't use the **INPUT ATT**, **TONE**, and **MIDNIGHT/LOUDNESS** buttons, as well as the **STANDARD**, **ADVANCED SURROUND**, and **STEREO/DIRECT** sound modes.
- When playback from the multi-channel inputs is selected, only the volume and channel levels can be set.

Using the sleep timer

The sleep timer switches the receiver into standby after a specified amount of time so you can fall asleep without worrying about the receiver being left on all night. Use the remote control to set the sleep timer.

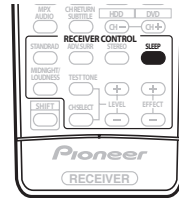

- **Press SLEEP repeatedly to set the sleep time.**

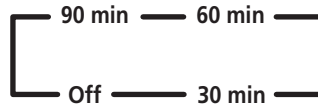

Tip

- You can check the remaining sleep time at any time by pressing **SLEEP** once. Pressing repeatedly will cycle through the sleep options again.
- You can also switch off the sleep timer simply by switching off the receiver.

Chapter 7:

Setting up the receiver

Choosing your receiver setup

To ensure the best possible surround sound, be sure to complete the following set up operations. This is particularly important when using DTS and Dolby surround. You only need to make these settings once (unless you change the placement of your current speaker system or add new speakers, etc.). Refer to the following pages for details on each of the settings.



Important

- If you are using the Pioneer S-FCRW730 speaker system, make sure the *Subwoofer setting* is set to **YES** and the *Speaker setting* is set to **FS-CS-SS**. You'll also have to change the *Crossover frequency setting* to **200Hz**.

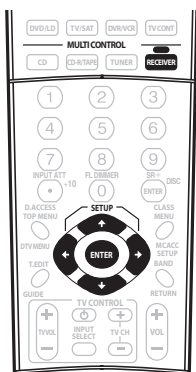

1 Press RECEIVER.

2 Use ⇐ or ⇒ to choose the option you want to adjust.

It will be easiest to adjust each of the settings in turn, following the order below (and on the following pages). The current setting is shown for each option as you cycle through the display.

Speaker setting (page 43)

Specify the number and type of speakers you have connected.

Surround back speaker setting (page 44)

Specify your surround back speaker/surround back subwoofer setup.

Subwoofer setting (page 44)

Specify how the subwoofer is used.

Crossover frequency setting (page 44)

Determine which frequencies will be sent to the subwoofer (or large speakers).

LFE attenuator setting (page 45)

Choose the attenuator level for the LFE channel.

Front left speaker distance setting (page 45)

Specify the distance from your listening position to your front left speaker.

Center speaker distance setting (page 45)

Specify the distance from your listening position to your center speaker.

Front right speaker distance setting (page 46)

Specify the distance from your listening position to your front right speaker.

Surround right speaker distance setting (page 46)

Specify the distance from your listening position to your surround right speaker.

Surround back speaker distance setting (page 46)

Specifies the distance from your listening position to your surround back speakers.

Surround left speaker distance setting (page 46)

Specify the distance from your listening position to your surround left speaker.

Subwoofer distance setting (page 46)

Specify the distance from your listening position to your subwoofer.

Dynamic range control setting (page 47)

Compress the dynamic range of the sound track.

Dual mono setting (page 47)

Isolate one channel when listening to discs with dual mono encoding.

Component video input settings (page 47)

Specify the components to be assigned to the component video inputs (below).

- Component video 1 input setting
- Component video 2 input setting

Digital input settings (page 47)

Specify the components to be assigned to the digital inputs (below).

- Coaxial digital input 1 setting
- Coaxial digital input 2 setting
- Optical digital input 1 setting
- Optical digital input 2 setting

SR+ control settings (page 48)

Specify how you want to control your Pioneer plasma display.

- Control mode setting

- Volume control setting
- Function setting for **DVD** input
- Function setting for **TV** input
- Function setting for **DVR** input
- Function setting for **VIDEO** input

3 Use \uparrow or \downarrow to adjust the setting.

The setting is entered automatically.

4 Repeat steps 2 and 3 to adjust other setup options.

5 When you're done, press ENTER to exit.



Note

- The setting display is automatically exited after 3 minutes of inactivity.

Speaker setting

- Default setting: **FL-CS-SS** (If a subwoofer is detected when you turn the receiver on, the default is **FS-CS-SS**.)

You must let the receiver know how many speakers you have, and how big they are. The size you choose (large or small) determines how much bass is sent from the receiver to the speakers.

In the display, **F**, **C**, and **S** refer to front, center, and surround speakers respectively. Speaker size is denoted as **L** for large speakers, **S** for small speakers, and * (asterisk) if no speaker is connected.



Note

- If the cone size (diameter) of the speaker is larger than 5 inches, set the speaker size to **L**.
- If you're not using a subwoofer, we recommend setting the front speakers to **L**.

Setting up the receiver

- Cycle through the available choices using \uparrow or \downarrow and choose a configuration that matches your speaker setup.

One of the following configurations should match your setup:

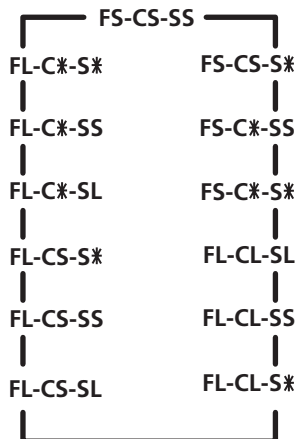

Surround back speaker setting

- Default setting: **S**

You must let the receiver know if surround back speaker(s) have been connected, and how big they are. The size you choose (large or small) determines how much bass is sent from the receiver to the speakers. If you have connected a subwoofer to the surround back terminals, you should select the surround back subwoofer setting (**SB SW**) from the options. Choose * (asterisk) if no speaker is connected.

- Use \uparrow or \downarrow to select **SB S**, **SB ***, **SB SW** or **SB L**.

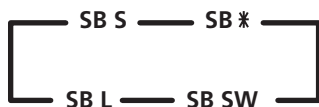

Note

- To select **SB L**, you must have **SL** selected in the *Speaker setting*.

Subwoofer setting

You can choose whether the subwoofer is used or not. Use the plus (**PLUS**) setting for extra bass.

- Use \uparrow or \downarrow to select the subwoofer setting.
 - **YES** – The LFE channel and bass frequencies from the small (**S**) speakers are sent to the subwoofer.
 - **PLUS** – The LFE channel and bass frequencies from all speakers are sent to the subwoofer (**L** speakers will also output bass).
 - **NO** – No bass frequencies are sent to the subwoofer.



Note

- If you chose the small front speaker setting, **SW YES** is automatically set and locked.

Crossover frequency setting

- Default setting: **100 Hz**

Crossover frequency is the point where the receiver divides the high and low sounds (the frequencies) between the speakers. Since most smaller speakers can't handle deep bass tones, you can send these sounds to the subwoofer (or if you don't have a subwoofer, the large (**L**) speakers in your system) instead of the speakers set to small (**S**) in your setup. Choose the point at which you want the frequency routed to the subwoofer (or **L** speakers).

We recommend setting this to **200 Hz** if your **S** speakers are smaller bookshelf-type speakers.

- Use \uparrow or \downarrow to specify the crossover frequency for your small speakers (100 Hz, 150 Hz or 200 Hz).

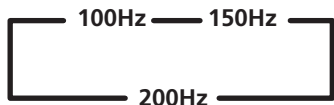

100 Hz

Sends bass frequencies below 100 Hz to the subwoofer (or **L** speakers).

150 Hz

Sends bass frequencies below 150 Hz to the subwoofer (or **L** speakers).

200 Hz

Sends bass frequencies below 200 Hz to the subwoofer (or **L** speakers).



Note

- If all speakers (front, center, and surround) are set to **L**, the crossover frequency can't be set because there are no **S** speakers (***) appears in the display).

LFE attenuator setting

- Default setting: **0 dB**

Dolby Digital and DTS audio sources include ultra-low bass tones. Set the LFE attenuator as necessary to prevent the ultra-low bass tones from distorting the sound from the speakers.

- Use \uparrow or \downarrow to set the attenuation level (0 dB, 10 dB or ** dB(∞)).

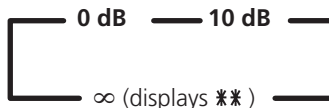

Note

- When ∞ is selected (** appears in the display), LFE is not available.

Front left speaker distance setting

- Default setting: **10 ft.**

Sets the distance from the front left speaker to the listening position.

- Use \uparrow or \downarrow to set the distance of the front left speaker from the main listening position (within the range of 0.5 ft. to 45 ft.).

Center speaker distance setting

- Default setting: **10 ft.**

The center speaker is normally placed directly in the front of the listening room and closer to the listening position than the front speakers. This means that the sound from the center speaker will be heard before the front speakers. To prevent this, set the center speaker distance setting to delay the sound from the center speaker so that the sound from the front and center speakers will be heard at the same time.

- Use **↑** or **↓** to set the distance of the center speaker from the main listening position (within the range of 0.5 ft. to 45 ft.).

**Note**

- When **C*** is selected in the speaker setting, the center speaker distance can't be set.

Front right speaker distance setting

- Default setting: **10 ft.**

Sets the distance from the front right speaker to the listening position.

- Use **↑** or **↓** to set the distance of the front right speaker from the main listening position (within the range of 0.5 ft. to 45 ft.).

Surround right speaker distance setting

- Default setting: **10 ft.**

You should set the distance of the surround speakers accurately to hear sounds coming from all speakers at the same time.

- Use **↑** or **↓** to set the distance of the surround right speaker from the main listening position (within the range of 0.5 ft. to 45 ft.).

**Note**

- When **S*** is selected in the speaker setting, the surround speaker distance can't be set.

Surround back speaker distance setting

- Default setting: **10 ft.**

You should set the distance of the surround back speakers accurately to hear sounds coming from all speakers at the same time.

- Use **↑** or **↓** to set the distance of the surround back speakers from the main listening position (within the range of 0.5 ft. to 45 ft.).

**Note**

- When **SB*** or **SB SW** is selected in the surround back speaker setting, the surround back speaker distance can't be set.

Surround left speaker distance setting

- Default setting: **10 ft.**

You should set the distance of the surround speakers accurately to hear sounds coming from all speakers at the same time.

- Use **↑** or **↓** to set the distance of the surround left speaker from the main listening position (within the range of 0.5 ft. to 45 ft.).

**Note**

- When **S*** is selected in the speaker setting, the surround speaker distance can't be set.

Subwoofer distance setting

- Default setting: **10 ft.**

Like your speakers, you should set the distance of the subwoofer accurately to hear sounds from all speakers at the same time.

- Use **↑** or **↓** to set the distance of the subwoofer from the main listening position (within the range of 0.5 ft. to 45 ft.).

 **Note**

- When **NO** is selected in the subwoofer setting, the subwoofer distance can't be set.

Dynamic range control setting

- Default setting: **OFF**

Dynamic range is the difference between the loudest and softest sounds in any given signal. With this setting, you can compress the dynamic range, so that low level sounds can be heard more easily (sounding relatively louder) yet louder sounds won't be too overbearing.

- Use **↑** or **↓** to set the dynamic range control (**OFF**, **MAX**, or **MID**).

 **Note**

- When listening at low volumes, set to **MAX** for maximum dynamic range compression.
- Dynamic range control is effective only when Dolby Digital and DTS signals are being played back.

Dual mono setting

- Default setting: **ch1**

The dual mono setting can only be used when listening to Dolby Digital and DTS signals with dual mono encoding. It is sometimes used when it is necessary to have one language on one channel and a different language on the other. With this setting you can choose which channel in the dual mono setting you want to listen to.

If Dolby Digital mode is switched on, you will hear the channel you have selected (either **ch1** or **ch2**) through your center speaker. With Dolby Digital mode off, or if you don't have a center speaker, you will hear the channel you have selected through both front speakers. In the **Lch1.Rch2** setting, the left front speaker will play channel 1 and the right front speaker will play channel 2.

- Use **↑** or **↓** to cycle through the possible dual mono settings.

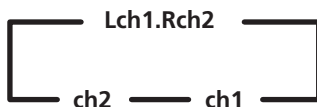

Component video input settings

Here you tell the receiver what components you have hooked up to the component video jacks on the back of the receiver.

Component video 1:

- Default setting: **DVD**

- 1 Use **↑** or **↓** to assign the component video 1 input (**DVD**, **TV**, **DVR** or **OFF**).

Component video 2:

- Default setting: **TV**

- 2 Use **↑** or **↓** to assign the component video 2 input (**DVD**, **TV**, **DVR** or **OFF**).

Digital input settings

Here you tell the receiver what components you have hooked up to the coaxial and optical **DIGITAL IN** jacks on the back of the receiver.

After you assign a component to a digital jack, whenever you select that component, (for example, a DVD player) the receiver automatically changes to the digital input setting and **DIGITAL** shows in the display.

Coaxial digital 1:

- Default setting: **DVD**
- Use **↑** or **↓** to assign the coaxial digital 1 input (**DVD, TV, CD, CDR, DVR or OFF**).

Coaxial digital 2:

- Default setting: **CD**
- Use **↑** or **↓** to assign the coaxial digital 2 input (**DVD, TV, CD, CDR, DVR or OFF**).

Optical digital 1:

- Default setting: **TV**
- Use **↑** or **↓** to assign the optical digital 1 input (**DVD, TV, CD, CDR, DVR or OFF**).

Optical digital 2

- Default setting: **DVR**
- Use **↑** or **↓** to assign the optical digital 2 input (**DVD, TV, CD, CDR, DVR or OFF**).

**Note**

- You can't assign two inputs to the same function. For example, assigning input 1 to the default setting of input 2 automatically switches input 2 to **OFF**.

SR+ control for Pioneer plasma displays

Make the following settings if you have connected a Pioneer plasma display to this receiver using an SR+ cable. Note that the number of function settings available will depend on the plasma display you've connected.

See also *Using this receiver with a Pioneer plasma display* on page 26 and *Using the SR+ mode with a Pioneer plasma display* on page 51.

Control mode setting

This must be switched to **SR+ ON** to access the settings below (default is **SR+ OFF**).

- **SR+ OFF** – Switches SR+ off (the receiver and plasma display work independently)
- **SR+ ON** – Switches SR+ on (the receiver sends control signals to the plasma display)

Volume control setting

- **VOL C OFF** – The receiver does not control the volume of the plasma display
- **VOL C ON** – When the receiver is switched to one of the inputs that use the plasma display (**DVD/LD**, or another one of functions listed below), the volume on the plasma display is muted so only sound from the receiver is heard.

Function setting for DVD/LD input

- **DVD:1 – DVD:5** or **TV** – Matches the **DVD/LD** function of the receiver with a numbered video input on the plasma display. For example, **DVD:3** matches the **DVD/LD** input with video input 3 on the plasma display.

Function setting for TV/SAT input

- **TV:1 – TV:5** or **TV** – Matches the **TV/SAT** function of the receiver with a numbered video input on the plasma display. For example, **TV:1** matches the **TV/SAT** input with video input 1 on the plasma display.

Function setting for DVR/VCR input

- **DVR:1 – DVR:5** or **TV** – Matches the **DVR/VCR** function of the receiver with a numbered video input on the plasma display. For example, **DVR:2** matches the **DVR/VCR** input with video input 2 on the plasma display.

Function setting for VIDEO input

- **VIDEO:1 – VIDEO:5** or **TV** – Matches the **VIDEO** function of the receiver with a numbered video input on the plasma display. For example, **VIDEO:4** matches the **VIDEO** input with video input 4 on the plasma display.

Manually calibrating your listening area (MCACC)

You can also use the Multi-Channel Acoustic Calibration (MCACC) system to manually fine tune your speaker levels and channel delay. These are calibrated according to the distance from your left front speaker to the listening position. You will hear a series of test tones that will allow you to set the speaker levels and channel delay to your liking. The advantage of doing this is that you can achieve an overall balance defined by the front speakers (the main speakers for home theater).



Important

- You must complete the *Speaker setting* on page 43 before using the MCACC setup.

- *VSX-D914 model only* – The microphone provided with your system must be disconnected from the front panel to use the MCACC manual setup.

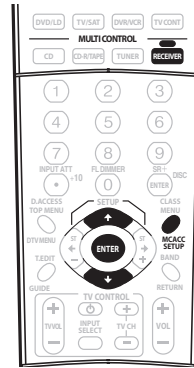

Caution

- These test tones can be loud, so take care that there is no one in the room who will be startled by the noise.

1 Press RECEIVER.

2 Press MCACC SETUP.

The MCACC system uses the left front speaker as a reference point to calibrate the speaker level and channel delay.

The front left speaker tone and the target speaker (the one that you're trying to adjust) tone will sound in turns, so you can judge which needs to be louder.

3 Use **↑** and **↓** to adjust each channel level in turn, pressing ENTER to go to the next channel when you're done.

The test tone is output in the following order (depending on the speaker setting):

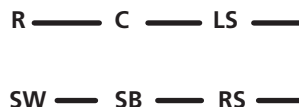

Setting up the receiver

4 Specify the distance from the front left speaker to your listening position using \uparrow and \downarrow then press ENTER.

5 Use \uparrow and \downarrow to adjust the delay for each channel in turn, pressing ENTER to go to the next channel when you're done.

Listen to the reference channel and use it to measure the target channel. Stand facing the two speakers with your arms outstretched pointing at each speaker. Try to make the two tones sound as if they are arriving simultaneously at a position slightly in front of you and between your arm span.

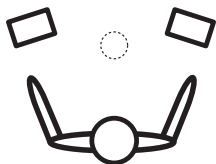

The test tone for channel delay is output in the same order as step 5:



After you have completed all the channels in your speaker setup, the volume level returns to normal and **COMPLETE**, then **RESUME** shows in the display.



Note

- Using the MCACC system to set up your speaker system will overwrite any previous settings you had for the **STANDARD** or **ADVANCED SURROUND** modes.

Setting separate channel levels for listening modes

- Default setting: **0 dB**

In addition to the MCACC setup, you can also set relative channel levels from the listening position using the method below. Using **CH SELECT** (see tip below), it is also possible to set separate channel levels for each of the listening modes.

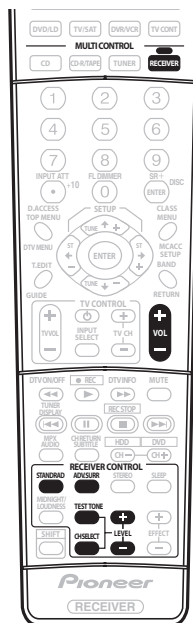

1 Press **RECEIVER**.

2 Press **STANDARD** or **ADV. SURR.** (**ADVANCED SURROUND**).

3 Press TEST TONE to output the test tone.

The test tone is output in the following order (depending on the speaker setting):

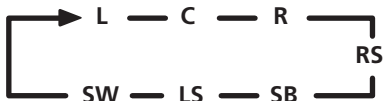

Note

- If you don't hear a test tone from one of your speakers, please refer to *Speaker setting* on page 43 and *Surround back speaker setting* on page 44 to make sure you have correctly specified your speaker setup.

4 Press MASTER VOLUME +/- to adjust the volume to an appropriate level.

5 Use LEVEL +/- to adjust the speaker levels in turn.

You should hear the test tone at the same volume from each speaker when seated in the main listening position. The channel level range is ± 10 dB.

6 When you're done, press TEST TONE to turn off the test tone.

The receiver returns to the Standard mode.

Tip

- The speaker volume can be adjusted without outputting the test tone by pressing **CH SELECT** and then using **LEVEL +/-**. However, you can only adjust the level of the speakers currently active in the mode you're listening to. You can set separate levels for the **STANDARD**, **STEREO** and **DVD 5.1 ch** modes, as well as for each **ADVANCED SURROUND** mode.

Note

- Since the subwoofer transmits an ultra-low frequency its sound may seem quieter than it actually is.
- Using test tones to set up your speaker system will overwrite any previous settings you had for the **STANDARD** or **ADVANCED SURROUND** modes.

Using the SR+ mode with a Pioneer plasma display

When connected using an SR+ cable, a number of features become available to make using this receiver with your Pioneer plasma display even easier. These features include:

- On-screen displays when making receiver settings, such as speaker setup, MCACC setup, and so on.
- On-screen volume display.
- On-screen display of listening mode.
- Automatic video input switching on the plasma display.
- Automatic volume muting on the plasma display.

See also *Using this receiver with a Pioneer plasma display* on page 26 for connecting up, and *SR+ control for Pioneer plasma displays* on page 48 for setting up the receiver.

1 Make sure that the plasma display and this receiver are switched on and that they are connected with the SR+ cable.

See *Using this receiver with a Pioneer plasma display* on page 26 for more on connecting these components.

2 To switch SR+ mode on/off, press RECEIVER, then the SR+ button.

The front panel display shows **SR+ CHECK**, then the new setting is displayed (**SR+ ON** or **SR+ OFF**).

**Note**

- The automatic volume muting feature is enabled separately; see *SR+ control for Pioneer plasma displays* on page 48. (You can also use the System Setup menu to switch the SR+ mode of the receiver.)
- If you disconnect the SR+ cable or switch the plasma display off while SR+ is on, the receiver will automatically revert to **SR+ OFF**.
- **SR+ ERR** shows in the display if no SR+ connection is detected (for example, the cable isn't connected).

Chapter 8: Using the tuner

Listening to the radio

The following steps show you how to tune in to FM and AM radio broadcasts using the automatic (search) and manual (step) tuning functions. If you already know the frequency of the station you want, see *Tuning directly to a station* below. Once you are tuned to a station you can memorize the frequency for recall later—see *Saving station presets* on page 54 for more on how to do this.



1 Press the TUNER button to select the tuner.

2 Use the BAND button to change the band (FM or AM), if necessary.

Each press switches the band between FM and AM.

3 Tune to a station.

There are three ways to do this:

Automatic tuning

To search for stations in the currently selected band, press and hold **TUNE +/-** for about a second. The receiver will start searching for the next station, stopping when it has found one. Repeat to search for other stations.

Manual tuning

To change the frequency one step at a time, press **TUNE +/-**.

High speed tuning

Press and hold **TUNE +/-** for high speed tuning. Release the button at the frequency you want.

Improving FM stereo sound

If the **TUNED** or **STEREO** indicators don't light when tuning to an FM station because the signal is weak, press the **MPX** button to switch the receiver into mono reception mode. This should improve the sound quality and allow you to enjoy the broadcast.

Tuning directly to a station

Sometimes, you'll already know the frequency of the station you want to listen to. In this case, you can simply enter the frequency directly using the number buttons on the remote control.

1 Press the TUNER button to select the tuner.

2 Use the BAND button to change the band (FM or AM), if necessary.

Each press switches the band between FM and AM.

3 Press D.ACCESS (Direct Access).

4 Use the number buttons to enter the frequency of the radio station.

For example, to tune to **106.00** (FM), press **1, 0, 6, 0, 0**.

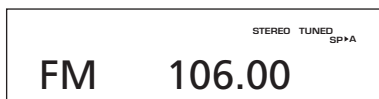

If you make a mistake halfway through, press **D.ACCESS** twice to cancel the frequency and start over.

Saving station presets

If you often listen to a particular radio station, it's convenient to have the receiver store the frequency for easy recall whenever you want to listen to that station. This saves the effort of manually tuning in each time. This unit can memorize up to 30 stations, stored in three banks, or classes, (A, B and C) of 10 stations each. When saving an FM frequency, the **MPX** setting (see page 53) is also stored. Use the front panel controls to store station presets.

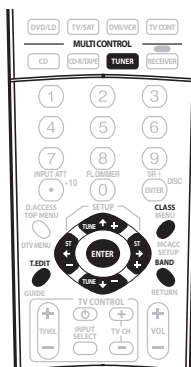
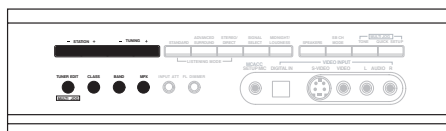
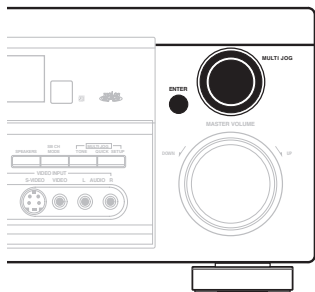

1 Tune to a station you want to memorize.

See *Listening to the radio* on page 53 for more on this.

2 Press T.EDIT (TUNER EDIT).

The display shows **ST. MEMORY**, then a blinking memory class.

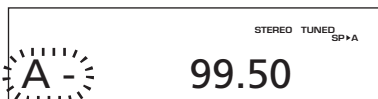

3 Press CLASS to select one of the three classes then press ST +/- (STATION +/-) to select the station preset you want.

You can also use the the **MULTI JOG** dial (front panel) to select a station preset.

4 Press ENTER.

After pressing **ENTER**, the preset class and number stop blinking and the receiver stores the station.

Naming station presets

For easier identification, you can name your station presets.

1 Choose the station preset you want to name.

See *Listening to station presets* below for how to do this.

2 Press T.EDIT (TUNER EDIT).

The display shows **ST. NAME**, then a blinking cursor at the first character position.

3 Input the name you want.

Names can be up to four characters long.

- Use the **MULTI JOG** dial (front panel) or the **ST +/-** buttons (remote) to select characters.
- Press **ENTER** to confirm a character. If no character is input, a space is input.
- The name is stored when **ENTER** is pressed after choosing the fourth character.



Tip

- To erase a station name, simply repeat steps 1-3 and input four spaces instead of a name.
- Once you have named a station preset, you can press **TUNER DISPLAY** when listening to a station to switch the display between the name and the frequency.

Listening to station presets

You will need to have some presets stored to do this. See *Saving station presets* on page 54 if you haven't done this already.

1 Press TUNER to select the tuner.

2 Press CLASS to select the class in which the station is stored.

Press repeatedly to cycle through classes A, B and C.

3 Press ST +/- (STATION +/-) to select the station preset you want.



Note

- If the receiver is left disconnected from the AC power outlet for an extended period, the station memories will be lost and will have to be reprogrammed.

Chapter 10:

Controlling the rest of your system

Setting the remote to control other components

Most components can be assigned to one of the **MULTI CONTROL** buttons using the component's manufacturer preset code stored in the remote.

However, please note that there are cases where only certain functions may be controllable after assigning the proper preset code, or the codes for the manufacturer in the remote control will not work for the model that you are using.

V SX-D914 only – If you can't find a preset code that matches the component you want to control, you can still teach the remote individual commands from another remote control (page 58).



Note

- TV codes (for example, codes for TV, CATV, Satellite TV or DTV) can only be assigned to the **TV/SAT** or **TV CONT** button.
- You can cancel or exit any of the steps by pressing **RECEIVER**. To go back a step, press **RETURN**.
- After one minute of inactivity, the remote automatically exits the operation.

Selecting preset codes directly



1 While pressing the **RECEIVER** button, press and hold the **1** button.

The remote LCD display shows **SETUP**.

2 Press the **MULTI CONTROL** button for the component you want to control.

The LCD on the remote displays the component you want to control.

- You can't assign the **RECEIVER** button.

3 Use **←** and **→** to select **PRESET** then press **ENTER**.

4 Use ↑ and ↓ to select the first letter of the brand name of your component then press ENTER.

This should be the manufacturer's name (for example, **P** for Pioneer).

5 Use ↑ and ↓ to select the manufacturer's name from the list then press ENTER

6 Use ↑ and ↓ to select the proper code from the list, then try using this remote control with your component.

The code should start with the component type (for example, **DVD_5305**). If there is more than one, start with the first one.

To try out the remote control, switch the component on or off (into standby) by pressing **SOURCE** . If it doesn't seem to work, select the next code from the list (if there is one).

- *VSX-D914 model only* – If you can't find or properly enter a preset code, you can still teach the remote individual commands from another remote control (see *Programming signals from other remote controls* below).

7 If your component is controlled successfully, press ENTER to confirm.

The remote LCD display shows **OK**.

Programming signals from other remote controls

VSX-D914 model only

If the preset code for your component is not available, or the available preset codes do not operate correctly, you can program signals from the remote control of another component. This can also be used to program additional operations (buttons not covered in the presets) after assigning a preset code.

1 While pressing the RECEIVER button, press and hold the 1 button.

The remote LCD display shows **SETUP**.

2 Press the MULTI CONTROL button for the component you want to control.

The LCD on the remote displays the component you want to control.

- You can't assign the **RECEIVER** button.

3 Use ⇐ and ⇒ to select LEARN then press ENTER.

PRES KEY and the **LEARN** icon show in the LCD display.

- To exit or cancel press **RECEIVER**.

4 Point the two remote controls towards each other then press the button that will be doing the learning on this receiver's remote control.

PRES KEY and the **LEARN** icon start flashing to indicate the remote is ready to accept a signal.

- The remote controls should be 1–2 inches apart.

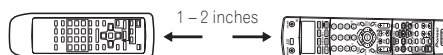

5 Press the corresponding button on the other remote control that is sending (teaching) the signal to this receiver's remote control.

For example, if you want to learn the playback control signal, press **▶**. The LCD display will show **OK** if the operation has been learned.

If for some reasons the operation hasn't been learned the LCD will display **ERROR** briefly and then display **PRES KEY** again. If this happens, keep pressing the (teaching) button as you vary the distance between the two remotes, until the LCD display shows **OK**.

Certain buttons represent operations that cannot be learned from other remote controls. The buttons available are shown below:

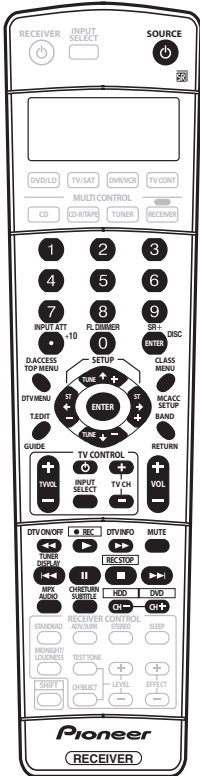

- 6 To program additional signals for the current component repeat steps 4 and 5. To program signals for another component, exit and repeat steps 1 through 5.
- 7 Press the RECEIVER button to exit and store the operation(s).

Note

- Some commands from other remote controls cannot be learned, but in most cases the remotes just need to be moved closer together or farther apart.
- If the remote LCD shows **FULL**, it means the memory is full. See *Erasing one of the remote control button settings* below to erase a programmed button you're not using to free up more memory.
- **TV CONTROL** buttons (TV \updownarrow , TV VOL +/-, TV CH +/- and INPUT SELECT) can only be learned after selecting TV/SAT or TV CONT.

Erasing one of the remote control button settings

VSX-D914 model only

This erases one of the buttons you have programmed and restores the button to the factory default.

- 1 While pressing the RECEIVER button, press and hold the 1 button. The remote LCD display shows **SETUP**.
- 2 Press the the MULTI CONTROL button corresponding to the button setting to be erased. The LCD on the remote displays the component.
- 3 Use \leftarrow and \rightarrow to select ERASE then press ENTER. The LCD display flashes **PRES KEY**.
- 4 Press and hold the button to be erased for two seconds. The LCD display shows **OK** to confirm the button has been erased. **NO CODE** is displayed if there is nothing to erase.

5 Repeat step 4 to erase other buttons.

6 Press the RECEIVER button when you're done.

Erasing all of the remote control presets

This will erase all preset remote control preset codes and (VSX-D914 model only) programmed buttons.

1 While pressing the RECEIVER button, press and hold the 1 button.

The remote LCD display shows **SETUP**.

2 Press any MULTI CONTROL button.

3 Use \leftarrow and \rightarrow to select RESET then press and hold ENTER for about two seconds.

The LCD shows **OK** to confirm the remote presets have been erased.

Direct function

- Default setting: **ON**

You can use the direct function feature to control one component using the remote control while at the same time, using your receiver to playback a different component. This could let you, for example, use the remote control to set up and listen to a CD on the receiver and then use the remote control to rewind a tape in your VCR while you continue to listen to your CD player.

When direct function is on, any component you select (using the **MULTI CONTROL** buttons) will be selected by both the receiver and the remote control. When you turn direct function off, you can operate the remote control without affecting the receiver.

1 While pressing the RECEIVER button, press and hold the 1 button.

The remote LCD display shows **SETUP**.

2 Press the MULTI CONTROL button for the component you want to control.

The LCD on the remote displays the component you want to control.

3 Use \leftarrow and \rightarrow to select DIRECT F then press ENTER.

The LCD on the remote displays the component you want to control.

4 Use \uparrow and \downarrow to switch direct function ON or OFF then press ENTER.

The LCD shows **OK** to confirm the setting.



Note

- You can't use direct function with the **TV CONT** function.

Confirming preset codes

Use this feature to check which preset code is assigned to a **MULTI CONTROL** button.

1 While pressing the RECEIVER button, press and hold the 1 button.

The remote LCD display shows **SETUP**.

2 Press the MULTI CONTROL button of the component for which you want to check the preset code.

3 Use \leftarrow and \rightarrow to select READ ID then press ENTER.

The brand name and preset code appears in the display for three seconds.

Controls for TVs

This remote control can control components after entering the proper codes or teaching the receiver the commands (see *Setting the remote to control other components* on page 57 for more on this). Use the **MULTI CONTROL** buttons to select the component.

Button(s)	Function	Components
TV	Switches the DTV on or off.	DTV
	Switches the TV or CATV between standby and on.	Cable TV/Satellite TV/TV
INPUT SELECT	Switches the TV input. (Not possible with all models.)	TV
TV CH +/-	Selects channels.	Cable TV/Satellite TV/TV/DTV
TV VOL +/-	Adjust the TV volume.	Cable TV/Satellite TV/TV/DTV
SOURCE	Press to switch the component assigned to the TV CONT button on or off.	Cable TV/Satellite TV/TV/DTV
	Switches the DTV on or off.	DTV
	Press to get information on DTV programs.	DTV
	Use to choose the BLUE commands on a DTV menu.	DTV
	Use to choose the YELLOW commands on a DTV menu.	DTV
	Use to choose the GREEN commands on a DTV menu.	DTV
	Use to choose the RED commands on a DTV menu.	DTV
AUDIO	Use to switch DTV audio tracks.	DTV
CH RETURN	Use to return to the previously selected channel.	Cable TV/Satellite TV/TV/DTV
DTV MENU	Press to display the DTV menu.	DTV
GUIDE	Use as the GUIDE button for navigating.	Cable TV/Satellite TV/TV/DTV
RETURN	Use to select closed captioning with DTV.	DTV
Number Buttons	Use to select a specific TV channel.	Cable TV/Satellite TV/TV/DTV
+10 button	Use to add a decimal point when selecting a specific TV channel.	DTV

Button(s)	Function	Components
ENTER/ DISC	Use to enter a channel.	Cable TV/Satellite TV/TV/DTV
MENU	Select different menus from the DTV functions.	DTV
	Select the menu screen.	Cable TV/Satellite TV/TV
ENTER	Press to select or adjust and navigate items on the menu screen.	Cable TV/Satellite TV/TV/DTV



Note

- The four **TV CONTROL** buttons on the remote control are dedicated to control the TV assigned to the **TV CONT** button. Thus if you only have one TV to hook up to this system assign it to the **TV CONT MULTI CONTROL** button. If you have two TVs, assign the main TV to the **TV CONT** button.

Controls for other components

This remote control can control these components after entering the proper codes or teaching the receiver the commands (see *Setting the remote to control other components* on page 57 for more on this). Use the **MULTI CONTROL** buttons to select the component.

Button (s)	Function	Components
SOURCE	Press to switch the component between standby and on.	CD/MD/CD-R/VCR/DVD/LD/DVR player/Cassette deck
⏮	Press to return to the start of the current track. Repeated presses skips to the start of previous tracks.	CD/MD/CD-R/DVD/LD player
	Go back channels (channel -).	DVR/VCR
⏭	Press to advance to the start of the next track. Repeated presses skips to the start of following tracks.	CD/MD/CD-R/DVD/LD player
	Go forward channels (channel +).	VCR
⏸	Pause playback or recording.	CD/MD/CD-R/VCR/DVD/LD/DVR player/Cassette deck
▶	Start playback.	CD/MD/CD-R/VCR/DVD/LD/DVR player/Cassette deck
⏩	Hold down for fast forward playback.	CD/MD/CD-R/VCR/DVD/LD/DVR player/Cassette deck
⏪	Hold down for fast reverse playback.	CD/MD/CD-R/VCR/DVD/LD/DVR player/Cassette deck

Button (s)	Function	Components
■	Stops playback (on some models, pressing this when the disc is already stopped will cause the disc tray to open).	CD/MD/CD-R/VCR/DVD/LD/ DVR player/Cassette deck
●	Starts recording. To prevent accidental recording, this button must be pressed twice to take effect (the second press must be within 10 seconds of the first).	MD/CD-R/VCR/ DVR player/ Cassette deck
Number buttons	Directly access tracks on a program source.	CD/MD/CD-R/VCR/LD player
	Use the number buttons to navigate the on-screen display.	DVD/DVR player
+10 button	Selects tracks higher than 10. (For example, press +10 then 3 to select track 13.)	CD/MD/CD-R/VCR/LD player
ENTER/ DISC	Chooses the disc.	Multiple CD player
	Ejects the disc.	MD player
	Use as the ENTER button.	VCR
	Use as the CLEAR button.	DVD
	Displays the setup screen for DVR players.	DVR player
	Changes sides of the LD.	LD player
TOP MENU	Displays the disc 'top' menu of a DVD player.	DVD/DVR player
MENU	Displays menus concerning the current DVD or DVR you are using.	DVD/DVR player
↑	Pauses the tape.	Cassette deck
↓	Stops the tape.	Cassette deck
ENTER	Starts playback.	Cassette deck
↔/⇒	Fast rewinds/fast forwards the tape.	Cassette deck
↔⇒↑↓ & ENTER	Navigates DVD menu/options.	DVD/DVR Player
GUIDE	Press to access the DVD player setup screen.	DVD/DVR Player
CH +/-	Selects channels.	VCR/DVD/DVR Player
	Selects tracks.	CD/MD/CD-R/Cassette deck
AUDIO	Changes the audio language or channel.	DVD/DVR Player

Button (s)	Function	Components
SUBTITLE	Displays/changes the subtitles on multilingual DVDs.	DVD/DVR Player
HDD (SHIFT + CH-)	Switches to the hard disk controls when using a DVD/HDD recorder.	DVR Player
DVD (SHIFT + CH+)	Switches to the DVD controls when using a DVD/HDD recorder.	DVR Player

Chapter 11: Additional information

Troubleshooting

Incorrect operations are often mistaken for trouble and malfunctions. If you think that there is something wrong with this component, check the points below. Sometimes the trouble may lie in another component. Investigate the other components and electrical appliances being used. If the trouble cannot be rectified even after exercising the checks listed below, ask your nearest Pioneer authorized service center or your dealer to carry out repair work.

Problem	Remedy
The power does not turn on.	<ul style="list-style-type: none"> • Connect the power plug to the wall outlet. • Disconnect the power plug from the outlet, and insert again. • Make sure there are no loose strands of speaker wire touching the rear panel. This could cause the receiver to shut off automatically. • If the power repeatedly shuts off automatically, take the unit to your nearest Pioneer authorized service center or your dealer for servicing.
No sound is output when a function is selected.	<ul style="list-style-type: none"> • Make sure the component is connected correctly (refer to <i>Connecting up</i> on page 16). • Press MUTE on the remote control to turn muting off.
No image is output when a function is selected.	<ul style="list-style-type: none"> • Make sure the component is connected correctly (refer to <i>Connecting up</i> on page 16). • Select the correct component (use the MULTI CONTROL buttons).
Considerable noise in radio broadcasts.	<ul style="list-style-type: none"> • Tune in the correct frequency. • Connect the antenna (refer to page 20). • Route any loose cables away from the antenna terminals and wires. • Fully extend the FM wire antenna, position for best reception, and secure to a wall. • Connect an outdoor FM antenna (refer to page 20). • Adjust the direction and position for best reception. • Connect an additional internal or external AM antenna (refer to page 20). • Turn off the equipment causing the noise or move it away from the receiver. • Place the antenna farther away from the equipment causing the noise.

Problem	Remedy
Broadcast stations cannot be selected automatically.	<ul style="list-style-type: none"> • Connect an outdoor antenna (refer to page 20).
No sound from surround or center speakers.	<ul style="list-style-type: none"> • Refer to <i>Speaker setting</i> on page 43 to check the speaker settings. • Refer to <i>Manually calibrating your listening area (MCACC)</i> on page 49 or the (VSX-D914 model only) <i>Quick surround sound setup</i> on page 14 to check the speaker levels. • Connect the speakers properly (refer to page 21).
No sound from surround back speakers.	<ul style="list-style-type: none"> • Refer to <i>Surround back speaker setting</i> on page 44 to check the surround back speaker settings. • Refer to <i>Manually calibrating your listening area (MCACC)</i> on page 49 or the (VSX-D914 model only) <i>Quick surround sound setup</i> on page 14 to check the speaker levels. • Refer to <i>Using the Surround Back Channel (SB CH)</i> on page 38 to make sure the SB CH MODE and the sound mode are set for surround back sound.
No sound from subwoofer.	<ul style="list-style-type: none"> • Make sure the subwoofer is switched on. • If the subwoofer has a volume knob, make sure it's turned up. • Switch the <i>Subwoofer setting</i> on page 44 to YES or PLUS. • Switch the <i>LFE attenuator setting</i> on page 45 to 0 dB or 10 dB. • The Dolby Digital or DTS source you are listening to does not have an LFE channel.
Noise during playback of a cassette deck.	<ul style="list-style-type: none"> • Move the cassette deck further from your receiver, until the noise disappears.
Sound is produced from other components, but not from LD or DVD player.	<ul style="list-style-type: none"> • Set the SIGNAL SELECT to AUTO, DIGITAL or ANALOG according to the type of connections made. (refer to page 37). • Set the digital input settings correctly (refer to page 47). • Make digital connections (refer to page 17) and set the SIGNAL SELECT to DIGITAL (refer to page 37). • Refer to the instruction manual supplied with the DVD player.
No sound is output or a noise is output when software with DTS is played back.	<ul style="list-style-type: none"> • Set the digital volume level of the player to full, or to the neutral position.
When a search is performed by a DTS compatible CD player during playback, noise is output.	<ul style="list-style-type: none"> • This is not a malfunction, but be sure to turn the volume down to prevent the output of loud noise from your speakers.

Problem	Remedy
Can't operate the remote control.	<ul style="list-style-type: none"> • Replace the batteries (refer to page 6). • Operate within 23 feet (7 m), 30° of the remote sensor on the front panel (refer to page 7). • Remove the obstacle or operate from another position. • Avoid exposing the remote sensor on the front panel to direct light.
The display is dark or off.	<ul style="list-style-type: none"> • Press FL DIMMER on the remote control repeatedly to return to the default.



Note

- If the unit does not operate normally due to external effects such as static electricity disconnect the power plug from the outlet and insert again to return to normal operating conditions.

Resetting the main unit

Use this procedure to reset all the receiver's settings to the factory default. Use the front panel controls to do this.

- 1 Switch the receiver on.**
- 2 While holding down the TONE button, press and hold the \odot STANDBY/ON button for about three seconds.**
- 3 When you see RESET? appear in the display, press the TONE button.**
OK? shows in the display.
- 4 Press TONE once more to confirm.**
OK appears in the display to indicate that the receiver has been reset to the factory default settings.

Switching the speaker impedance

We recommend using speakers of 8Ω with this system, but it is possible to switch the impedance setting if you plan to use speakers with a 6Ω impedance rating.

- **With the receiver in standby, press \odot STANDBY/ON while holding down the SPEAKERS button.**
Each time you do this, you switch between the impedance settings:
 - **SP 6 OHM** – Use this setting if your speakers are rated at 6Ω.
 - **SP 8 OHM** – Use this setting if your speakers are rated at 8Ω or more.

Specifications

Amplifier section

Continuous average power output of 110 watts (VSX-D914) / 100 watts (VSX-D814)* per channel, min., at 8 ohms, from 20 Hz to 20,000 Hz with no more than 0.2%** total harmonic distortion (front).

Continuous power output (stereo)

VSX-D914 (Front) 110 W
(20–20,000 Hz, THD 0.2 %, 8 Ω)
VSX-D814 (Front) 100 W
(20–20,000 Hz, THD 0.2 %, 8 Ω)

Continuous power output (surround)

VSX-D914
Front 110 W per channel
(1kHz, 1.0 %, 8 Ω)
Center 110 W (1kHz, 1.0 %, 8 Ω)
Surround 110 W per channel
(1kHz, 1.0 %, 8 Ω)
Surround Back 110 W per channel
(1kHz, 1.0 %, 8 Ω)
VSX-D814
Front 100 W per channel
(1kHz, 1.0 %, 8 Ω)
Center 100 W (1kHz, 1.0 %, 8 Ω)
Surround 100 W per channel
(1kHz, 1.0 %, 8 Ω)
Surround Back 100 W per channel
(1kHz, 1.0 %, 8 Ω)

Input (Sensitivity/Impedance)

CD, DVR/VCR, CD-R/TAPE/MD,
DVD/LD, TV/SAT 200 mV/47 kΩ

Frequency response

CD, DVR/VCR, CD-R/TAPE/MD, DVD/LD,
TV/SAT 5 Hz to 100,000 Hz ± 3 dB

Output (Level/Impedance)

DVR/VCR REC, CD-R/TAPE/
MD REC 200 mV/2.2 kΩ

Tone control

Bass ± 6 dB (100 Hz)
Treble ± 6 dB (10 kHz)
Loudness . . . +6.5 dB/+3 dB (100 Hz/10 kHz)
(at volume level -50 dB)

Signal-to-Noise Ratio (IHF, short circuited, A network)

CD, DVR/VCR, CD-R/TAPE/MD,
DVD/LD, TV/SAT 96 dB

Signal-to Noise Ratio [EIA, at 1 W (1 kHz)]

CD, DVR/VCR, CD-R/TAPE/MD,
DVD/LD, TV/SAT 79 dB

Video Section

Input (Sensitivity/Impedance)

DVR/VCR, DVD/LD, TV/SAT 1 V_{p-p}/75 Ω

Output (Level/Impedance)

DVR/VCR, MONITOR OUT 1 V_{p-p}/75 Ω

Frequency response

DVR/VCR, DVD/LD,
TV/SAT ⇒ MONITOR 5 Hz to 7 MHz ± 0.5 dB
Signal-to-Noise Ratio 55 dB

Component video section

Input (Sensitivity)

DVD/LD, TV/SAT 1 V_{p-p}/75 Ω

Output (Level/Impedance)

MONITOR OUT 1 V_{p-p}/75 Ω



Dear Customer:

Selecting fine audio equipment such as the unit you've just purchased is only the start of your musical enjoyment. Now it's time to consider how you can maximize the fun and excitement your equipment offers. This manufacturer and the Electronic Industries Association's Consumer Electronics Group want you to get the most out of your equipment by playing it at a safe level. One that lets the sound come through loud and clear without annoying blaring or distortion—and, most importantly, without affecting your sensitive hearing.

Sound can be deceiving. Over time your hearing "comfort level" adapts to higher volumes of sound. So what sounds "normal" can actually be loud and harmful to your hearing. Guard against this by setting your equipment at a safe level BEFORE your hearing adapts.

To establish a safe level:

- Start your volume control at a low setting.
- Slowly increase the sound until you can hear it comfortably and clearly, and without distortion.

Once you have established a comfortable sound level:

- Set the dial and leave it there.

Taking a minute to do this now will help to prevent hearing damage or loss in the future. After all, we want you listening for a lifetime.

We Want You Listening For A Lifetime

Used wisely, your new sound equipment will provide a lifetime of fun and enjoyment. Since hearing damage from loud noise is often undetectable until it is too late, this manufacturer and the Electronic Industries Association's Consumer Electronics Group recommend you avoid prolonged exposure to excessive noise. This list of sound levels is included for your protection.

Decibel

Level	Example
30	Quiet library, soft whispers
40	Living room, refrigerator, bedroom away from traffic
50	Light traffic, normal conversation, quiet office
60	Air conditioner at 20 feet, sewing machine
70	Vacuum cleaner, hair dryer, noisy restaurant
80	Average city traffic, garbage disposals, alarm clock at two feet.

THE FOLLOWING NOISES CAN BE DANGEROUS UNDER CONSTANT EXPOSURE

90	Subway, motorcycle, truck traffic, lawn mower
100	Garbage truck, chain saw, pneumatic drill
120	Rock band concert in front of speakers, thunderclap
140	Gunshot blast, jet plane
180	Rocket launching pad

Information courtesy of the Deafness Research Foundation.



S001 en

Should this product require service in the U.S.A. and you wish to locate the nearest Pioneer Authorized Independent Service Company, or if you wish to purchase replacement parts, operating instructions, service manuals, or accessories, please call the number shown below.

8 0 0 - 4 2 1 - 1 4 0 4

Please do not ship your product to Pioneer without first calling the Customer Support Division at the above listed number for assistance.

Pioneer Electronics (USA) Inc.
Customer Support Division
P.O. BOX 1760, Long Beach,
CA 90801-1760, U.S.A.

For warranty information please see the Limited Warranty sheet included with your product.

Should this product require service in Canada, please contact a Pioneer Canadian Authorized Dealer to locate the nearest Pioneer Authorized Service Company in Canada.

Alternatively, please contact the Customer Satisfaction Department at the following address:

Pioneer Electronics of Canada, Inc.
Customer Satisfaction Department
300 Allstate Parkway, Markham, Ontario L3R OP2
(905)479-4411
1(877)283-5901

For warranty information please see the Limited Warranty sheet included with your product.

Si ce produit doit être réparé au Canada, veuillez vous adresser à un distributeur autorisé Pioneer du Canada pour obtenir le nom du Centre de Service Autorisé Pioneer le plus près de chez-vous. Vous pouvez aussi contacter le Service à la clientèle de Pioneer:

Pioneer Electroniques du Canada, Inc.
Service à la clientèle
300, Allstate Parkway, Markham, Ontario L3R OP2
(905)479-4411
1(877)283-5901

Pour obtenir des renseignements sur la garantie, veuillez vous reporter au feuillet sur la garantie restreinte qui accompagne le produit.

S018D_enfr

Published by Pioneer Corporation
Copyright©2003 Pioneer Corporation
All rights reserved

PIONEER CORPORATION

4-1, Meguro 1-Chome, Meguro-ku, Tokyo 153-8654, Japan

PIONEER ELECTRONICS (USA) INC.

P.O. BOX 1540, Long Beach, California 90810-1540, U.S.A. TEL: (800) 421-1404

PIONEER ELECTRONICS OF CANADA, INC.

300 Allstate Parkway, Markham, Ontario L3R OP2, Canada TEL: (905) 479-4411

PIONEER EUROPE NV

Haven 1087, Keetberglaan 1, B-9120 Melsele, Belgium TEL: 03/570.05.11

PIONEER ELECTRONICS ASIACENTRE PTE. LTD.

253 Alexandra Road, #04-01, Singapore 159936 TEL: 656-472-1111

PIONEER ELECTRONICS AUSTRALIA PTY. LTD.

178-184 Boundary Road, Braeside, Victoria 3195, Australia, TEL: (03) 9586-6300

PIONEER ELECTRONICS DE MEXICO S.A. DE C.V.

Bldv.Manuel Avila Camacho 138 10 piso Col.Lomas de Chapultepec, Mexico,D.F. 11000 TEL: 55-9178-4270

K002E

Free Manuals Download Website

<http://myh66.com>

<http://usermanuals.us>

<http://www.somanuals.com>

<http://www.4manuals.cc>

<http://www.manual-lib.com>

<http://www.404manual.com>

<http://www.luxmanual.com>

<http://aubethermostatmanual.com>

Golf course search by state

<http://golfingnear.com>

Email search by domain

<http://emailbydomain.com>

Auto manuals search

<http://auto.somanuals.com>

TV manuals search

<http://tv.somanuals.com>