

JB6X Series Platform Scale Quick Reference Card

About Your Scale The JB6X Series platform scale is an accessory to your mailing and shipping systems. It allows you to process packages that exceed your system's weight or size limits.

The information provided on this card will help you understand the scale's features and use.

What's What The JB6X Series scale has rollers built into the platform for ease in handling heavy packages. The built-in leveling bubble located under the platform provides a means of leveling the platform.

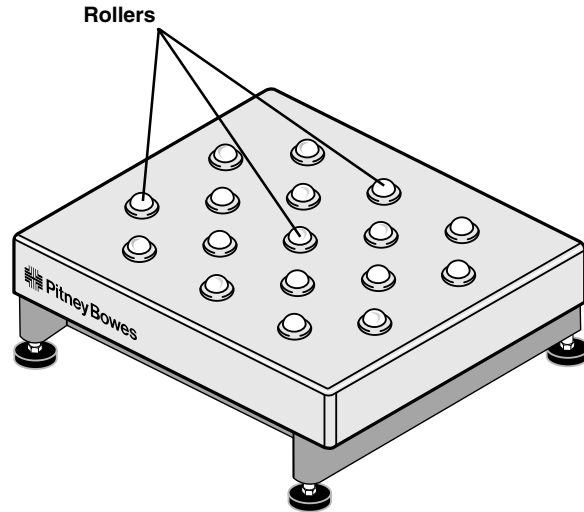

- Safety Precautions**
- Use the equipment only for its intended purpose.
 - Place the platform close to an easily accessible wall outlet. Avoid using outlets controlled by wall switches or shared by other equipment.
 - To protect against electric shock, plug the AC adapter into a properly grounded wall outlet only.
 - DO NOT route the AC adapter cable over sharp edges or trap it between pieces of furniture.

- Safety Precautions (Continued)**
- Do not remove covers; if the platform has been dropped or has had the enclosure stressed in any way, call the Pitney Bowes help number in your host system user guide.
 - Do not place lighted candles, cigarettes, cigars, etc., on the platform.
 - Use only the AC adapter/power supply included with this platform.
 - Always follow the specific occupational safety and health standards prescribed for your workplace.

Warm-up Time 10 minutes.

Troubleshooting

Symptom	Probable Cause	Recommendation
No weight reading.	Scale power supply unplugged.	Ensure scale is plugged into wall outlet and host system.
Negative weight indicator displays.	Heavy object left on scale for a long time.	Ensure no object is touching the scale and press the zero key.
	Zero key pressed with object on scale.	Remove object and press the zero key.
	Scale was not re-zeroed after certain functions were performed.	Press the zero key.
Overweight indicator displays.	Object on platform exceeds scale's maximum weighing capacity.	Remove overweight object and press the zero key.
Scale does not return to zero.	Interference with scale platform.	Remove objects around scale and press the zero key.
Scale does not reach weight capacity.	Platform incorrectly seated or mechanical interference.	Ensure platform correctly seated. Check for foreign matter under platform.
Inconsistent weights.	Air currents moving across platform.	Move scale to another location.
	Scale in motion.	Stabilize scale.
	Platform or item being weighed touching another object.	Clear area around scale.

Leveling the Scale

Remove the platform, then turn the four adjustable feet as needed to center the bubble (in the leveling eye) to level the scale.

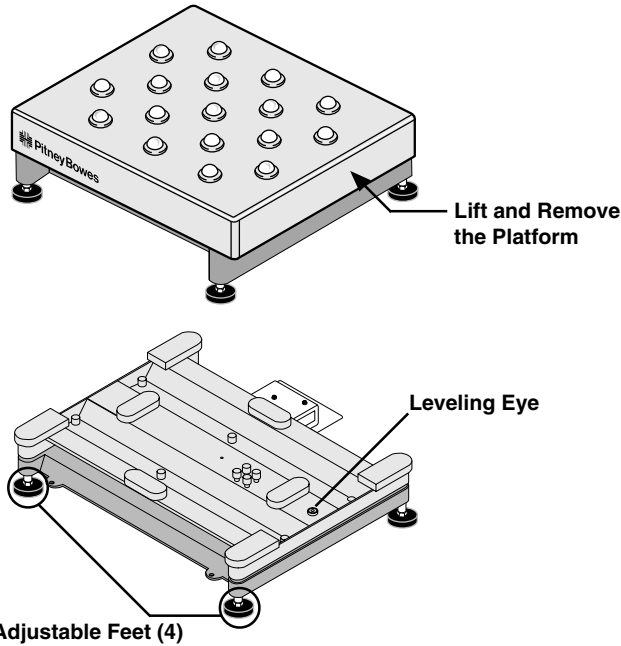

Making Connections

Refer to the drawing below if you ever have to reconnect cables.

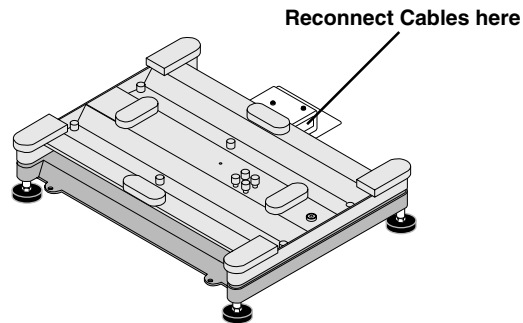

Cleaning the Scale

Your scale needs very little maintenance. Simply wipe it off with a soft, dry cloth. Do not use harsh chemical cleaners.

Weighing Ranges (Multi-Range)

Weight Range JB64
0 to 50 lb x 1.0 oz
0 to 200 lb x 2.0 oz

Weight Range JB67
0 to 50 lb x 0.5 oz
0 to 149 lb x 2.0 oz

Product Specifications

Category	Description
Height:	W/platter: 5.5" (140mm)
Weight:	54 lb (24.5kg)
Shipping weight:	62 lb (28kg)
Base:	19.5 in x 15.5 in (495mm x 394mm)
Platter:	19.75 in x 15.75 in (502mm x 400mm)
Signal Cable Length:	10' Serial
Operating Temp.:	+50°F to 104°F (10°C to 40°C)
Voltage:	115 Vac
Frequency:	60 ± 1 Hz
Communications:	RS-232C
Baud Rate:	4800/9600

Getting Help

If you believe the scale is not working properly or if you have questions about it, refer to the help numbers in your host system user guide.

FCC Notice

This equipment has been tested and found to comply with the limits for a Class A digital device, pursuant to Part 15 of the FCC rules. These limits are designed to provide reasonable protection against harmful interference when the equipment is operated in a commercial environment. This equipment generates, uses, and can radiate radio frequency and energy and, if not installed and used in accordance with the instruction manual, may cause harmful interference to radio communications. Operation of this equipment in a residential area is likely to cause harmful interference in which case the user will be required to correct the interference at his own expense.



Free Manuals Download Website

<http://myh66.com>

<http://usermanuals.us>

<http://www.somanuals.com>

<http://www.4manuals.cc>

<http://www.manual-lib.com>

<http://www.404manual.com>

<http://www.luxmanual.com>

<http://aubethermostatmanual.com>

Golf course search by state

<http://golfingnear.com>

Email search by domain

<http://emailbydomain.com>

Auto manuals search

<http://auto.somanuals.com>

TV manuals search

<http://tv.somanuals.com>