



THE PLASMON *INFINITY*

LF 6602

OPTICAL DISK DRIVE

User Manual

P/N 97654438 E



New features and changes to information in this document are indicated by change bars. Revision level is indicated by the letter following the eight-digit document number. If a document has undergone major modifications, change bars will not be inserted in the document.

Reproduction of this manual, or any portion of this manual, is prohibited without the express permission of Plasmon Laser Magnetic Storage (LMS). Plasmon LMS reserves the right to make changes in this document and the product referred to herein without prior notice.

© 1999 Plasmon Laser Magnetic Storage

WARNING



Always observe the following when installing, operating or maintaining this product:

- This unit must be connected to a power distribution system that has a direct connection to earth ground (Terminated Terra [TT] network/ground connected). This unit is not suitable for use on a floating ground (Interrupted Terra [IT]) network.
- The AC input power cord must be shielded and must have a minimum current rating of 10 A with a nominal cross-section area of 0.75 sq mm (reference: AWG #18) per conductor, 2 wires plus ground and product safety approvals as required for use in the country in which the unit is installed.
- When the unit is mounted in an equipment rack or cabinet, be certain that the internal temperature within the rack or cabinet does not exceed the limits defined in the Product Specification or this document.
- To ensure the integrity of safety features of this unit, maintenance must be performed only by qualified service personnel using designated Plasmon LMS parts.
- In case of fire or other emergency, isolate the units from the main power by disconnecting the power plugs from their site power receptacles. In situations where disconnecting the plugs is not possible or practical, use the system main power disconnect to isolate the units from the main power.
- To prevent fire or shock hazard, do not expose this unit to rain or moisture. Refer servicing to qualified technicians.

(German Translation)

WARNUNG



- Bei der Installation, Bedienung und Wartung dieses Produkts, bitte immer die folgenden Vorsichtsmaßnahmen treffen:
- Dieses Gerät muß an ein Stromversorgungssystem angeschlossen werden, das direkt mit einem Erdungsanschluß verbunden ist (Terminated- Terra-Netz [TT]/mit Erdanschluß). Dieses Gerät kann nicht an ein ungeerdetes Netz (Interrupted Terra [IT]) angeschlossen werden.
- Die Verbindungsschnur des Wechselstromeingangs muß entstört sein und ihr Minimalstrom unter folgenden Bedingungen bei 10 A liegen: Der Nennquerschnitt beträgt 0,75 mm je Leiter (Referenz: American Wire Gauge Nr. 18), es bestehen 2 Drähte plus ein Erdanschluß und das Produkt entspricht den im Land, in dem es aufgestellt wird, geltenden Sicherheitsvorschriften.
- Wird das Gerät in ein Gerätegestell oder einen Geräteschrank eingebaut, ist darauf zu achten, daß die interne Temperatur im Gestell oder Schrank nicht über die in den Produktspezifikationen oder diesem Dokument angegebenen Grenzwerte hinausgeht.
- Um ein ordnungsgemäßes Funktionieren der Sicherheitsmerkmale dieses Gerätes zu gewährleisten, dürfen Wartungsarbeiten nur von qualifiziertem Fachpersonal ausgeführt werden. Es sind darüber hinaus nur Ersatzteile zu verwenden, die von der Firma Plasmon LMS angegeben werden.
- Im Falle eines Feuers oder in einem anderen Notfall sind die Geräte vom Hauptnetz zu trennen, indem die Netzstecker aus den Steckdosen am Einbauort gezogen werden. Ist ein Herausziehen der Stecker nicht möglich oder zu umständlich, trennen Sie die Geräte mit Hilfe des System- Hauptnetzabschalters vom Hauptnetz.
- Um Feuer- oder Stromschlaggefahr zu vermeiden, ist dieses Gerät niemals Regen oder Feuchtigkeit auszusetzen. Wartungsarbeiten sind qualifiziertem technischen Personal zu überlassen.

Radio/TV Interference (USA)

The information in this section applies only to units in use within the United States:

This equipment generates and uses radio frequency energy and, if not installed and used properly, that is, in strict accordance with the manufacturer's instruction, may cause interference to radio and television reception. It has been type tested and found to comply with the limits for a Class A computing device in accordance with the specifications of Part 15 of FCC Rules, which are designed to provide reasonable protection against such interference in a residential installation. However, there is no guarantee that interference will not occur in a particular installation. If this equipment does cause interference to radio or television reception, which can be determined by turning the equipment off and on, the user is encouraged to try to correct the interference by one or more of the following measures:

- reorient the receiving antenna
- relocate the equipment away from the receiver
- plug the equipment into a different outlet so that equipment and receiver are on different branch circuits.

If necessary, the user should consult the dealer or an experienced radio/television technician for additional suggestions. A pamphlet by the FCC 'How to Identify and Resolve Radio-TV Interference Problems' is available from the US Government Printing Office, Washington, D.C., 20402, Stock No. 044-000-00345-4.

CDRH COMPLIANCE

LF 6602 contains a Class 1 Laser Product. This product complies with 21CFR Chapter 1, Subchapter J, applicable at date of manufacture.

CANADIAN EMI COMPLIANCE

Canadian Department of Communications standards require that the following statement appear in operating manuals for any digital apparatus imported into Canada:

This digital apparatus does not exceed the Class A limits for radio noise for digital apparatus set out in the Radio Interference Regulations of the Canadian Department of Communications.

FRENCH TRANSLATION

Cet équipement digital ne dépasse pas les limites de la Classe A pour les interférences radioélectriques des systèmes digitaux fixées par les Règlements concernant les Interférences Radioélectriques établis par le Ministère des Communications du Canada.

All Plasmon LMS products comply with the requirements of this standard.

Agency Compliance and Approval

For details on Agency Compliance and Approval refer to the *LF 6602 Product Specification Manual*.

TABLE OF CONTENTS

<i>SCOPE</i>	9
RELATED PUBLICATIONS	9
<i>GENERAL DESCRIPTION</i>	11
<i>DRIVE CHARACTERISTICS</i>	13
FRONT PANEL	13
REAR PANEL	14
DIMENSIONS AND WEIGHT	15
TEMPERATURE, HUMIDITY AND ALTITUDE	16
SHOCK AND VIBRATION	17
AC POWER REQUIREMENTS	17
AC GROUND	18
AC POWER CORD	18
TILT RANGE	18
HEAT DISSIPATION	18
PARTICULATE LIMITS	18
WARNING LABELS	19
<i>UNPACKING AND REPACKING INSTRUCTIONS</i>	21
UNPACKING THE LF 6602	21
INSPECTING THE LF 6602	27
REPACKING THE LF 6602	27
<i>INSTALLATION</i>	33
INSTALLATION REQUIREMENTS	33
SCSI BUS CONSIDERATIONS	34
CONNECTING POWER AND SCSI CABLING	37
SINGLE-DEVICE CONFIGURATION	38
MULTIPLE-DEVICE CONFIGURATION	39
CONNECTOR VERIFICATION	39
EXTENSION PROCEDURES	40
<i>OPERATING INSTRUCTIONS</i>	43
CONTROLS AND INDICATORS	43
POWER-ON PROCEDURE	45
MODES OF OPERATION	46
OPERATING MODE	46
CONFIGURATION MODE	48
TEST MODE	70

MEDIA CARTRIDGE HANDLING	71
SETTING THE WRITE PROTECTION SWITCH	73
AFFIXING LABELS	74
MEDIA INSERTION AND REMOVAL	74
MEDIA ACCESS DOOR	74
CARTRIDGE INSERTION	76
CARTRIDGE REMOVAL	77
MANUAL CARTRIDGE RELEASE MECHANISM	78
MEDIA LOADING	82
<i>OPERATOR MAINTENANCE</i>	83
ACCESSING DRIVES	83
INSPECTING AND CLEANING FAN AND BLOWER FILTERS	85
REPLACING FUSES	86
MEDIA CLEANING	87
MEDIA CLEANING USING CLEANING KIT P/N 97662550	87
<i>ACCESSORIES</i>	89
<i>APPENDIX A</i>	93
GERMAN TRANSLATIONS/ ÜBERSETZUNGEN INS DEUTSCHE	93

This User Manual describes unpacking, installing, operating, and maintaining the Plasmon Infinity LF 6602 RapidChangert High-Performance Optical Disk Drive.

RELATED PUBLICATIONS

Publication	Part Number
LM 6000 Media Product Specification	97647044
LF 6600 User Manual	97653976
LD 6100/LF 6600 SCSI Interface Specification	97653978
LD 6100 Hardware Maintenance Manual	97653979
LF 6600/LF 6602 Hardware Maintenance Manual	97653980
LD 6100 User Manual	97654437

WARRANTY STATEMENT

The LF 6602 is warranted as stated in the purchase agreement between Plasmon and it's customer, or the Plasmon sales order acknowledgment, whichever is applicable.

The Plasmon LMS quality system is in compliance and registered to ISO 9001. The LF 6602 is manufactured from new parts, or remanufactured parts.

LF 6602 warranty does not cover defects or damage caused by the use of unauthorized parts or repairs or improper use or maintenance. Repairs or replacements not covered by the warranty will be invoiced at LMS' then current prices.

The warranty is void when installation, service or repairs are performed by unauthorized personnel; when the product is affected by unauthorized alterations, modifications or other tampering or misuse; when the product is incorporated into a system which causes or involves any changes in the physical, mechanical or electrical arrangement of the product; or when the product is not used in accordance with its applicable specifications.

The term, authorized personnel, is defined as those persons who have been trained by Plasmon LMS Technical Services.

GENERAL DESCRIPTION

The Plasmon Infinity LF 6602 RapidChanger is a cabinet configuration, housing two LF 6600 RapidChanger drives side-by-side, as shown in the next figure.

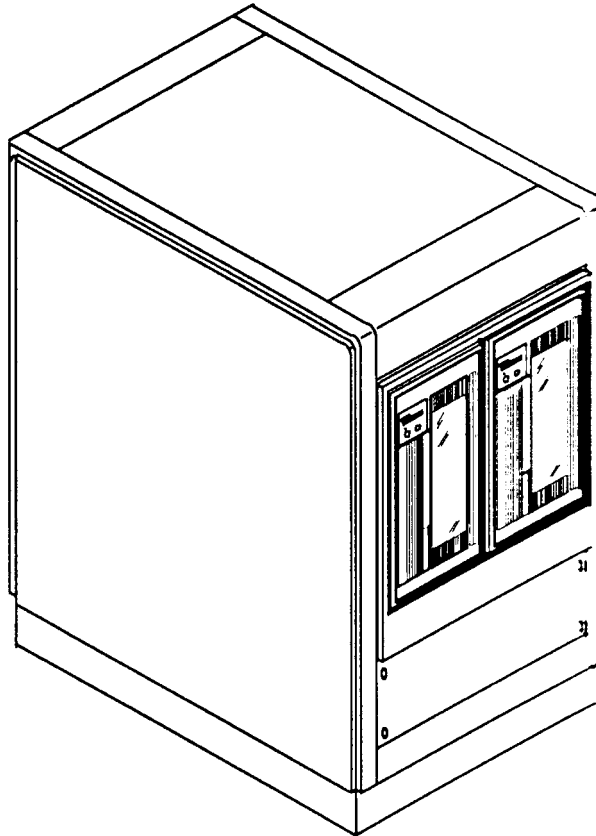

LF 6602 Configuration

EP006028

Each LF 6600 drive is a write once read many (WORM), high-capacity, optical disk drive with an integral shuttle, capable of holding up to six LM 6000/LM 4000 media cartridges. The integral shuttle moves laterally to position one of the media cartridges for automated loading and unloading into the optical drive.

The LF 6602 provides 24 GBytes of online storage and up to 144 GBytes of nearline storage. Each LF 6602 provides 12 GBytes of online storage and up to 72 GBytes of nearline storage. Each LM 6000 media cartridge has a capacity of 12 GBytes.

A Drive Operator Console (DOC) located on the front panel of each drive provides user control of drive operation and configuration as explained in the Operating Instruction section of this manual. Operating messages are presented on the alphanumeric display in English, French or German. The language used is selectable.

Each drive's front panel includes a lockable media access door to provide operator access to the shuttle and media cartridges.

The Auxiliary Diagnostic Port (ADP), located on the rear panel of each drive, can be used to download updates to the drive firmware in the field. Refer to the LD 6100/LF 6600/LF 6602 Product Specification (P/N 97653977) for more information.

Each LF 6602 drive supports a sustained read transfer rate of 2.7 MBytes/sec with error correction and defect management capabilities to maintain data integrity and manage media flaws. Each LF 6600 implements the Small Computer System Interface (SCSI) via standard SCSI-2 micro-connectors located on the rear panels. Single-ended and differential interface options are available, and the interface can be changed in the field. Both the single-ended and differential controllers support asynchronous or synchronous data transfer operations.

Preventive maintenance for the LF 6602 is minimal (refer to the Operator Maintenance section). Corrective maintenance is simplified by internal diagnostic firmware which detects, isolates, and reports malfunctions to the operator and identifies the faulty Field Replaceable Unit (FRU).

LM 6000 media is interchangeable between the LF 6602, LF 6600 and the LD 6100. The 6000 series of drives will also read LM 4000 media written by the Plasmon LMS 4000 series of optical drive products (except for media with serial numbers less than X0010000, where X designates an A or B).

DRIVE CHARACTERISTICS

FRONT PANEL

The LF 6602 front panel is shown in the figure below. The LF 6600 bezels, which contain the Drive Operator Console (DOC), media access door and door lock, protrude through a frame in the cabinet. A drive's bezel can be removed to gain access to that drive.

Refer to the Operating Instruction section for a detailed description of the DOC.

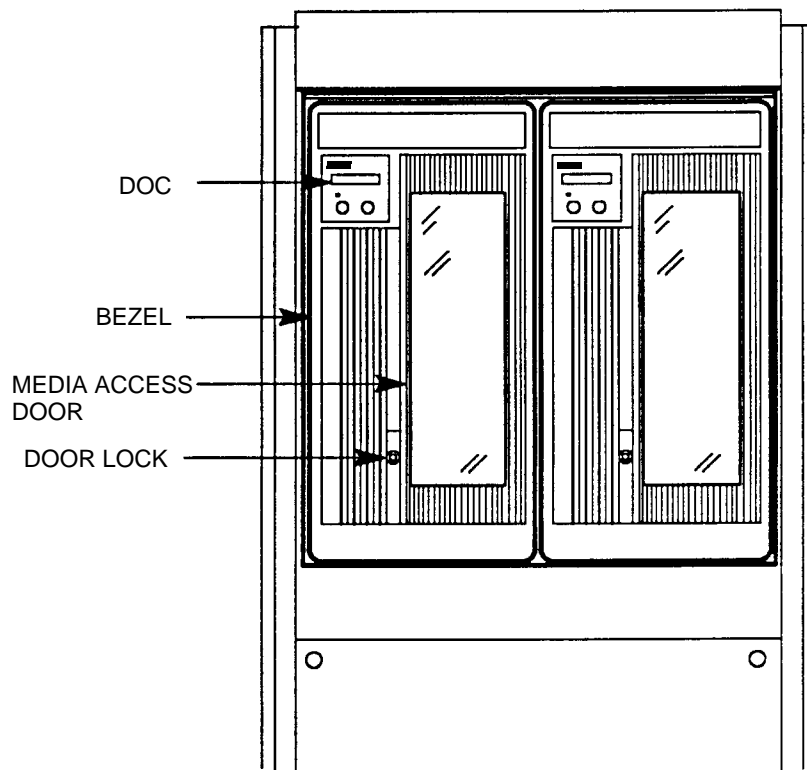

LF 6602 Front Panel

EP006030

REAR PANEL

On the rear of the LF 6602 cabinet, a louvered door with a latch and a key lock covers the access to the rear of the LF 6600 drives (refer to figure below).

To gain access to the drives' power switches, ADP and SCSI interface connectors, unlock the door, press up on the latch and open the door. The drives' AC power source is provided by the power socket strip, located on the bottom of the rear panel within the cabinet. The primary AC cord for the LF 6602 is connected to the power socket strip.

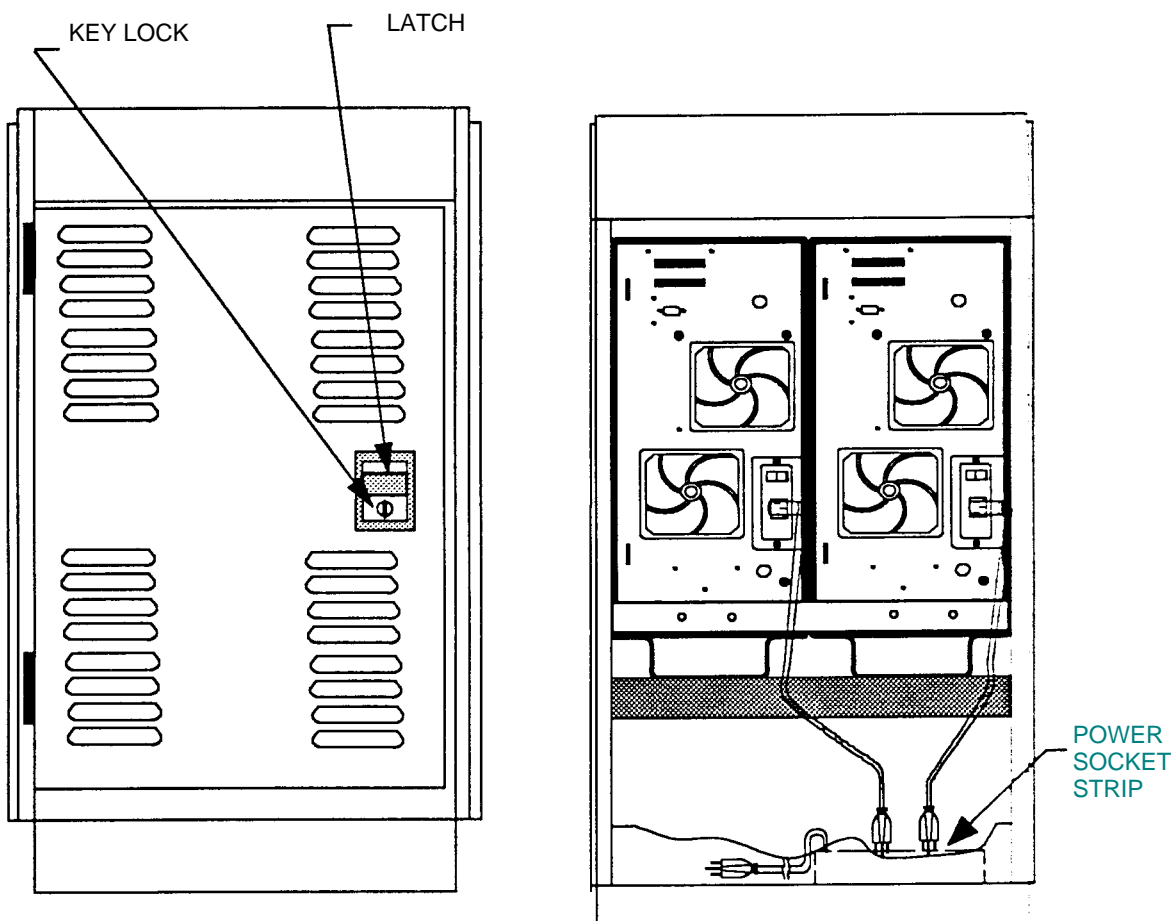

LF 6602 Rear Panel

EP006031

DIMENSIONS AND WEIGHT

The LF 6602's reference dimensions, are shown in the next table.

Height:	99.9 cm (39.3 in)
Width:	53.6 cm (21.1 in)
Depth:	81.3 cm (32.0 in)
Weight:	204 kg (450 lb)

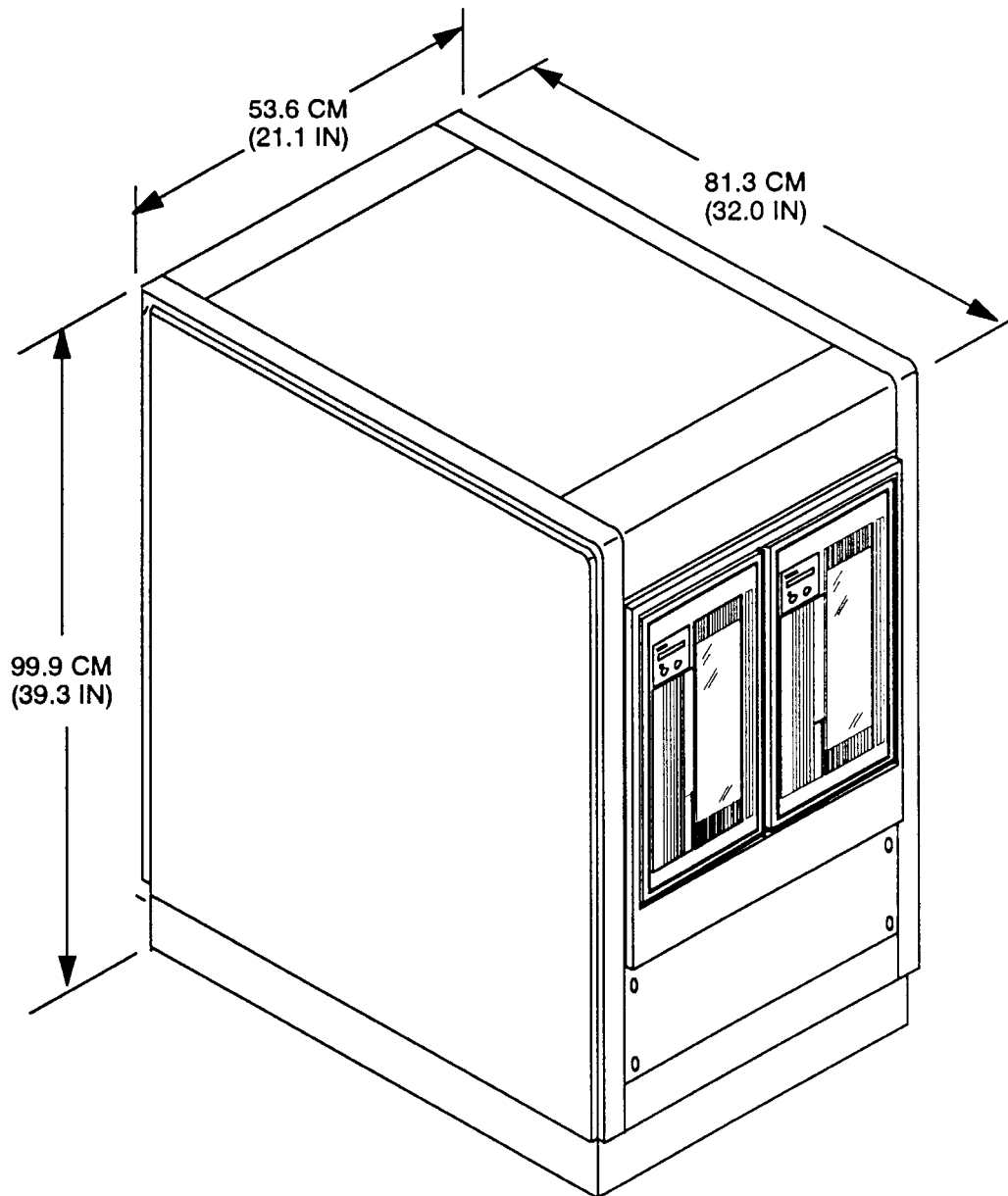

LF 6602 Dimensions

EP006029

TEMPERATURE, HUMIDITY AND ALTITUDE

The following table lists the temperature, humidity and altitude limits for the LF 6600 drives installed in the LF 6602.

Temperature, Humidity and Altitude Limits

CONDITION	OPERATING	NONOPERATING	STORAGE/TRANSIT ¹
Temperature	10° to 42° C ² (50° to 108° F)	-40° to 66° C (-40° to 151° F)	-40° to 66° C (-40° to 151° F)
Maximum Rate of Change	11° C/hr (20° f/hr)	20° C/hr (36° F/hr)	20° C/hr (36° F/hr)
Humidity (Noncondensing)	10 to 90%	5 to 95%	5 to 95%
Maximum Rate of Change	10%/hr	10%/hr	10%/hr
Maximum Wet Bulb Temperature	28° C (82° F)	46°C (115° F)	46°C (115° F)
Minimum Dew Point	2° C (35.6°)	2° C (35.6°)	2° C (35.6°)
Altitude	-300 to 3,000 m (-984 to 9840 ft) without Media -300 to 2,000 m (-984 to 6562 ft) with Media	-300 to 3,000 m (-984 to 9840 ft)	Storage -300 to 3,000 m (-984 to 9840 ft) Transit -300 to 12,000 m (-984 to 40,000 ft) with Media

- 1 Storage specifications are for 90 days maximum in Plasmon LMS packaging. No condensation is permitted. Transit specifications are based on a maximum 1-week period in a factory-sealed container.
- 2 Maximum operating temperature is 42 °C for a free-standing drive at sea level unless otherwise stated. Maximum operating temperature is derated linearly above 300 m altitude to 38 °C at 2,000 m altitude.
- 3 See the LD 6100/LF 6600/LF 6602 Product Specification (P/N 97653977) for more information concerning the temperature and humidity operating range.
- 4 Media limits maximum operating altitude to 2000 m. For conditions and limits pertaining to the media, refer to the LM 6000 Media Specification (P/N 97647044).

SHOCK AND VIBRATION

The table below lists the conditions and limits for shock and vibration for the LF 6602.

Shock and Vibration Criteria and Limits

CONDITION	OPERATING	NONOPERATING ¹	STORAGE/TRANSIT ²
Swept Vibration (Bidirectional) 1 Octave/Min	5 to 22 Hz 0.01 in Double Amplitude, 22 to 500 Hz 0.25 g Peak	5 to 44 Hz, 0.03 in Double Amplitude, 44 to 500 Hz 3.0 g Peak	5 to 44 Hz, 0.03 in Double Amplitude, 44 to 500 Hz 3.0 g Peak
Shock ³ (Host Retries May Be Required and Drive Performance May Degrade During Test)	10 - msec Half Sine Pulse of 5.0 g Peak ⁴		
Unpacked (3 Axis)		5 - msec Half Sine Pulse of 5.0 g Peak	
Packed on Pallet			31 - cm (18 - in) Drop Test Flat

1 With media removed 2 In LMS-approved packaging 3 Shock repetition rate should be limited to allow mechanical system transients to subside between pulses. 4 Limit at 5.0 g peak for LF 6602 cabinet. Limit at 3.0 g peak in LF 6600/LF 6602 in front-to-back axis because media in shuttle will be displaced. The drive is not designed for prolonged operation at these shock levels.

AC POWER REQUIREMENTS

The primary AC power cord type will depend on the LF 6602 configuration ordered. The primary AC power cord supplies power to the [power socket strip located within the LF 6602 cabinet](#). Each LF 6602 is connected to the power socket strip with a grounded AC power cord. The power connector of each LF 6600 is integrated into the AC power receptacle. Over current protection is provided by two fuses, which are also integrated into the receptacle with two spare fuses. Refer to the [Replacing Fuses](#) section for the fuse replacement procedure.

Each drive's power supply accepts the input line voltages listed in Table 3. The power supply is autoranging and does not require mechanical switching for input voltage or frequency selection.

AC Power Requirements

FREQUENCY	AC VOLTAGE	CURRENT (TYPICAL)	SPIN - UP SURGE ¹	MINIMUM SERVICE RATINGS
47 to 66 Hz	86.7 to 128 V	3.0 A	10.0 A	15 A
47 to 66 Hz	173.4 to 268 V	1.5 A	5.0 A	15 A

1 Less than 1 sec, cold start

NOTE

After the power has been turned off, the operator must wait 1 second before turning on the power again

AC GROUND

The LF 6602 chassis must be connected to earth ground for operator safety. The AC power cord has a grounding conductor which connects the LF 6602 chassis to safety ground through the site AC power system. If the site AC system ties its ground wire connection to earth ground, then the LF 6602 chassis will also be tied to earth ground. All site AC power connections must be maintained on the same safety ground.

A line grounding connector located on the rear panel of each LF 6600 can also be used to tie the drive chassis to earth ground. These ground connectors are 6-mm (0.24-in.) M4 with a nut and lock washer.

AC POWER CORD

The type of AC power cord supplied with the LF 6602 will depend upon the configuration ordered.

POWER SUPPLY OUT-OF-RANGE PROTECTION FEATURES

Each LF 6600 power supply provides over and under voltage protection, over current protection, power failure detection and over temperature protection. Should an out-of-range condition occur, each LF 6600 detects it and shuts down the DC outputs of the power supply.

NOTE

After the situation is corrected, power can be restored by turning the AC power switch to the off position, waiting 1 sec and then turning the power switch to the on position again.

TILT RANGE

The LF 6602 is not designed for use when tilted from the vertical position.

HEAT DISSIPATION

The LF 6602 cabinet will typically represent a heat load of 292 kg-calories/hr (1160 BTU/hr) during a read/write operation. When media cartridges are inserted, loaded, spun up, spun down, unloaded and removed at each drive's maximum rate, the LF 6602 will typically represent a heat load of 364 kg-calories/hr (1450 BTU/hr).

PARTICULATE LIMITS

The LF 6602 is designed for use in an office or computer room. The environment must have a low dust level. Each drive filters incoming air for cooling to reduce the quantity of particles entering the drive; however, the filters are not effective against small particles (including tobacco smoke). These particles will become deposited on optical components and media, causing a degradation in drive performance. Refer to the Operator Maintenance section for media cleaning and air filter cleaning instructions.

WARNING LABELS

The LF 6602 is classified as a laser product. As such it is subject to United States federal requirements covering laser products. The warning labels shown in the next figure are required to ensure compliance with federal regulations and must not be removed from the LF 6600 drives within the cabinet.

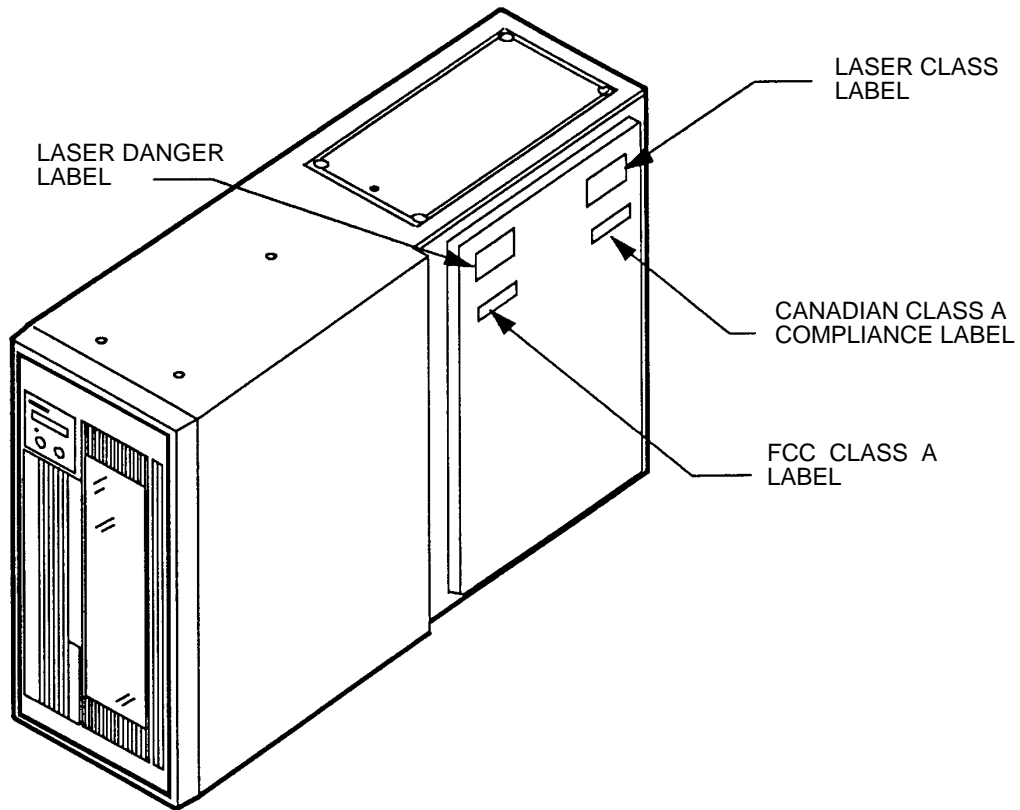

Location of LF 6600 Warning Labels

EP006043

UNPACKING AND REPACKING INSTRUCTIONS

If the Laser Drive's shipping carton shows evidence of rough handling or damage, return the unit in it's carton to your supplier and request a replacement.

UNPACKING THE LF 6602

The LF 6602 is shipped with foam packing material which protects the unit from shock and vibration. After you receive your LF 6602, inspect the shipping carton for damage before unpacking the unit to substantiate a claim with the carrier if the unit is damaged. Retain all original packing materials for possible reshipment.

WARNING



Physical injury will result if you attempt to lift the LF 6602 without using proper equipment.

When the LF 6602 is being unpacked or transported, ensure that the unit is tilted no more than 10 degrees from the vertical position. The LF 6602 weighs more than 181 kg (400 lbs). If the unit is tilted more than 10 degrees, it can topple over, causing personal injury.

To unpack the LF 6602, you will need the following tools:

- diagonal cutters
- One T-15 screwdriver
- One #2 cross recess screwdriver
- One 1/2-in. socket wrench

To unpack the LF 6602, perform the following procedure:

- 1) Cut the banding straps and remove the plastic corners.
- 2) Lift the shipping carton up, off the LF 6602, and remove the ramp and the foam cushion.
- 3) Remove the protective bag from the unit and then remove all adhesive tape from the unit's exterior, such as on the key lock on the rear of the cabinet.

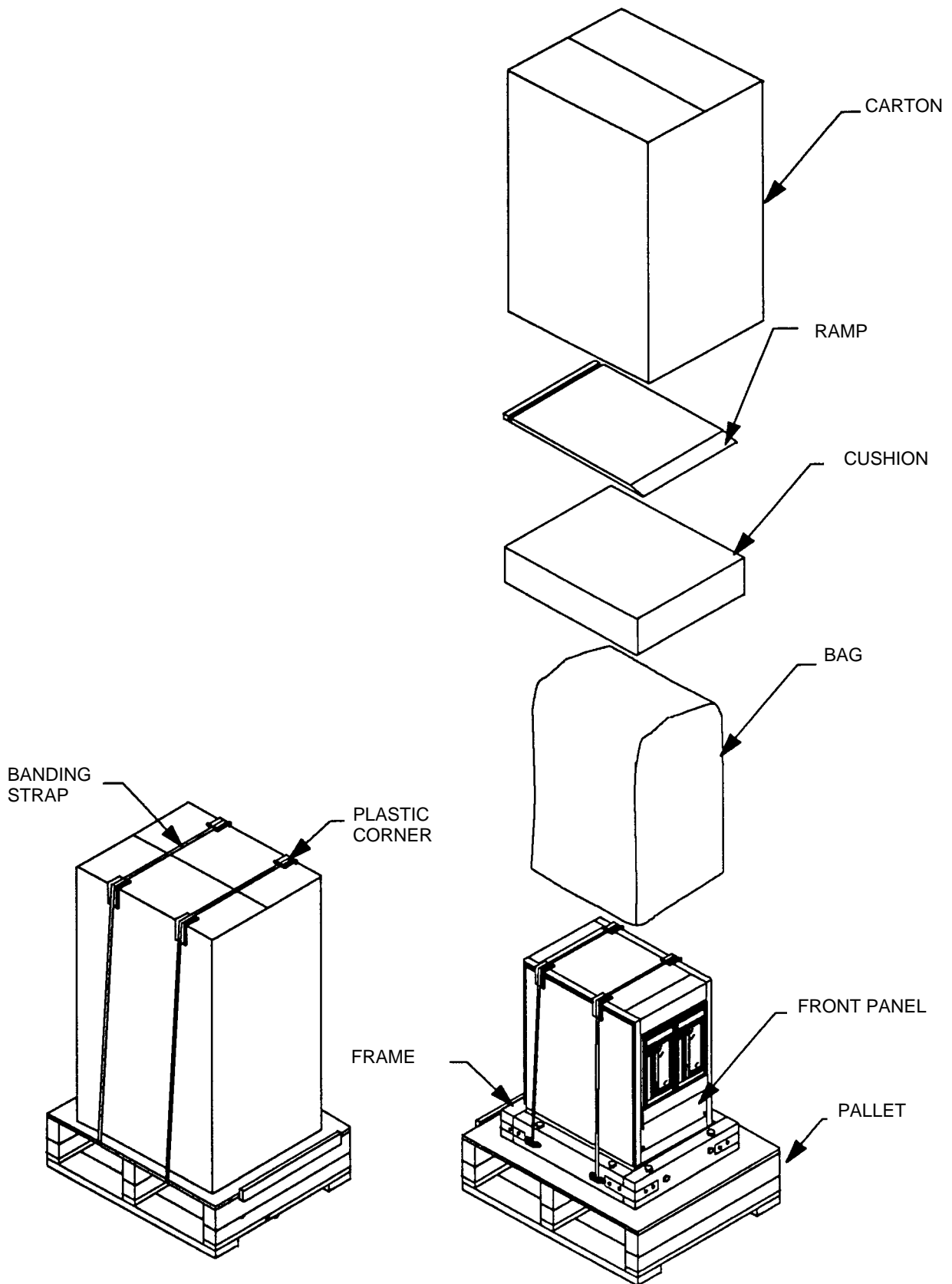

Unpacking the LF 6602

EP005015

- 4) Cut the banding straps that secure the unit to the pallet and removes plastic corners.

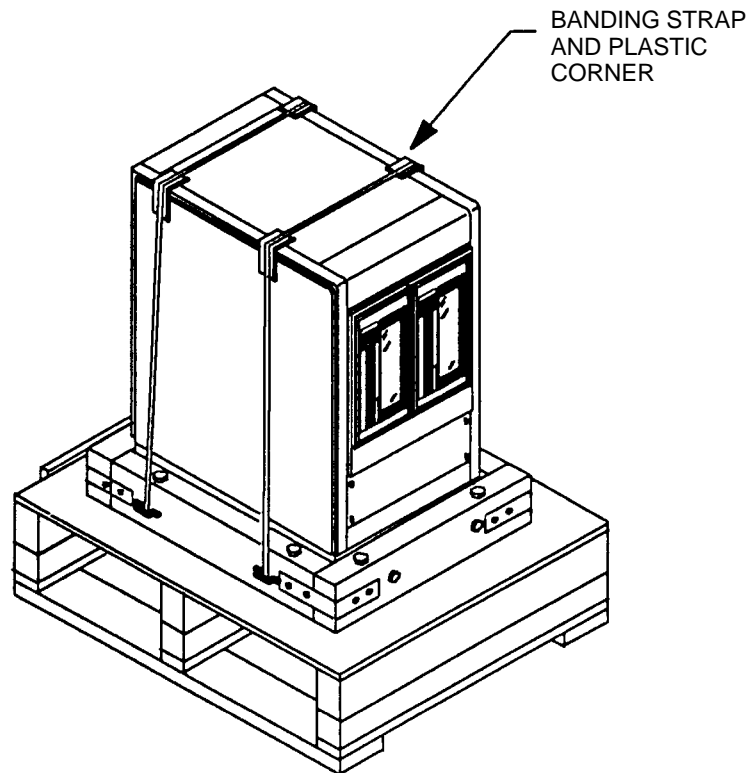

Removing Banding Straps from LF 6602

EP005016

- 5) Unlock and unlatch the LF 6602's rear door (see next figure).
- 6) With the LF 6602's rear door open, unfasten and remove the two bolts from the front of the frame using a 1/2 in. socket wrench. Ensure that you pull the bolts completely out of the frame.
- 7) Loosen, but do not remove, the two bolts on the back of the frame. Part of the wood frame will then angle out, thereby lowering the LF 6602 onto its casters.
- 8) With the #2 cross recess screwdriver, remove the four screws from each bracket on the front of the frame, and then remove the brackets and the wood support.

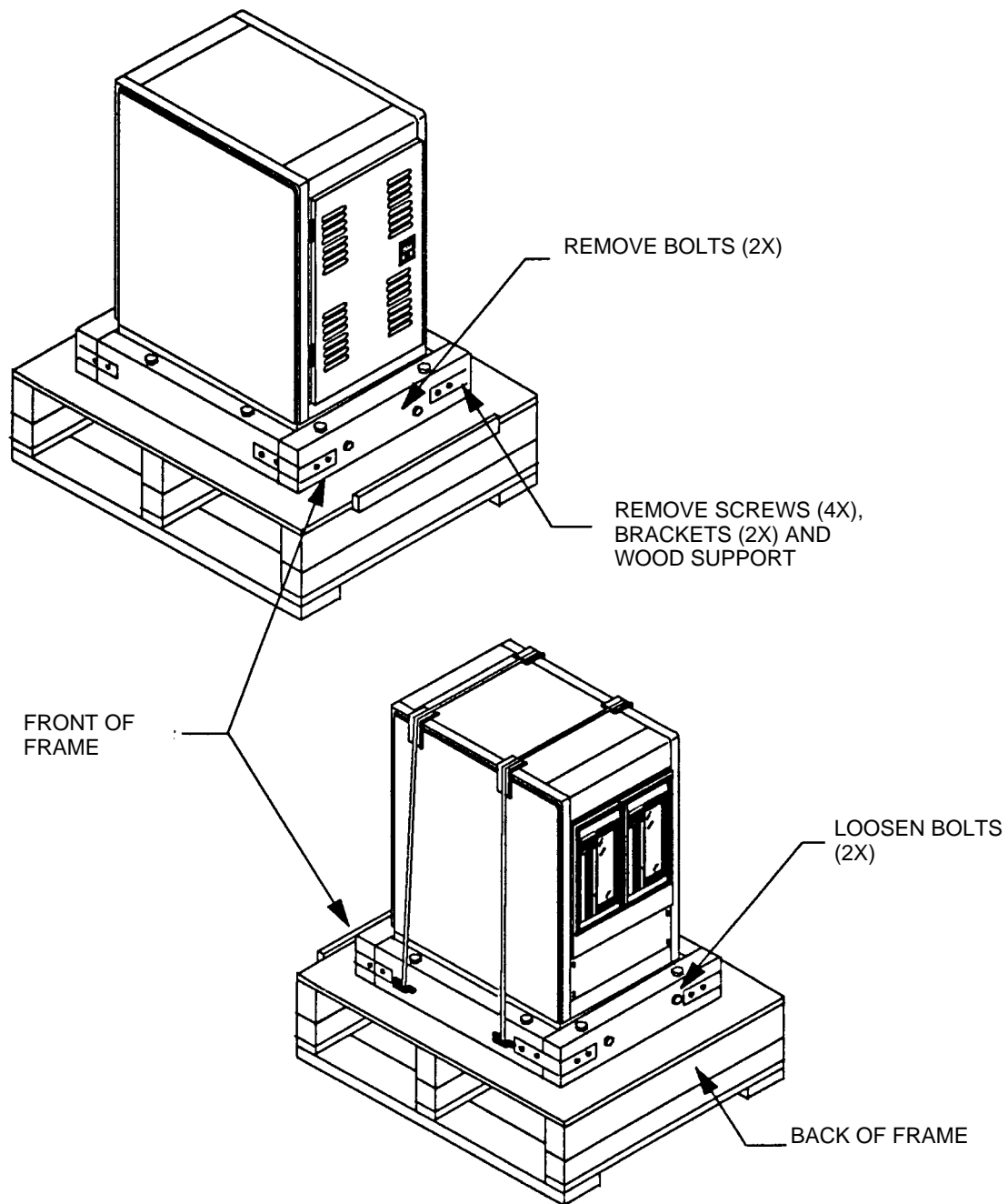

Removing Bolts from Front of Frame; Loosening Bolts from Back of Frame

EP005017

9) Place the ramp on the front lip of the pallet (see figure below).

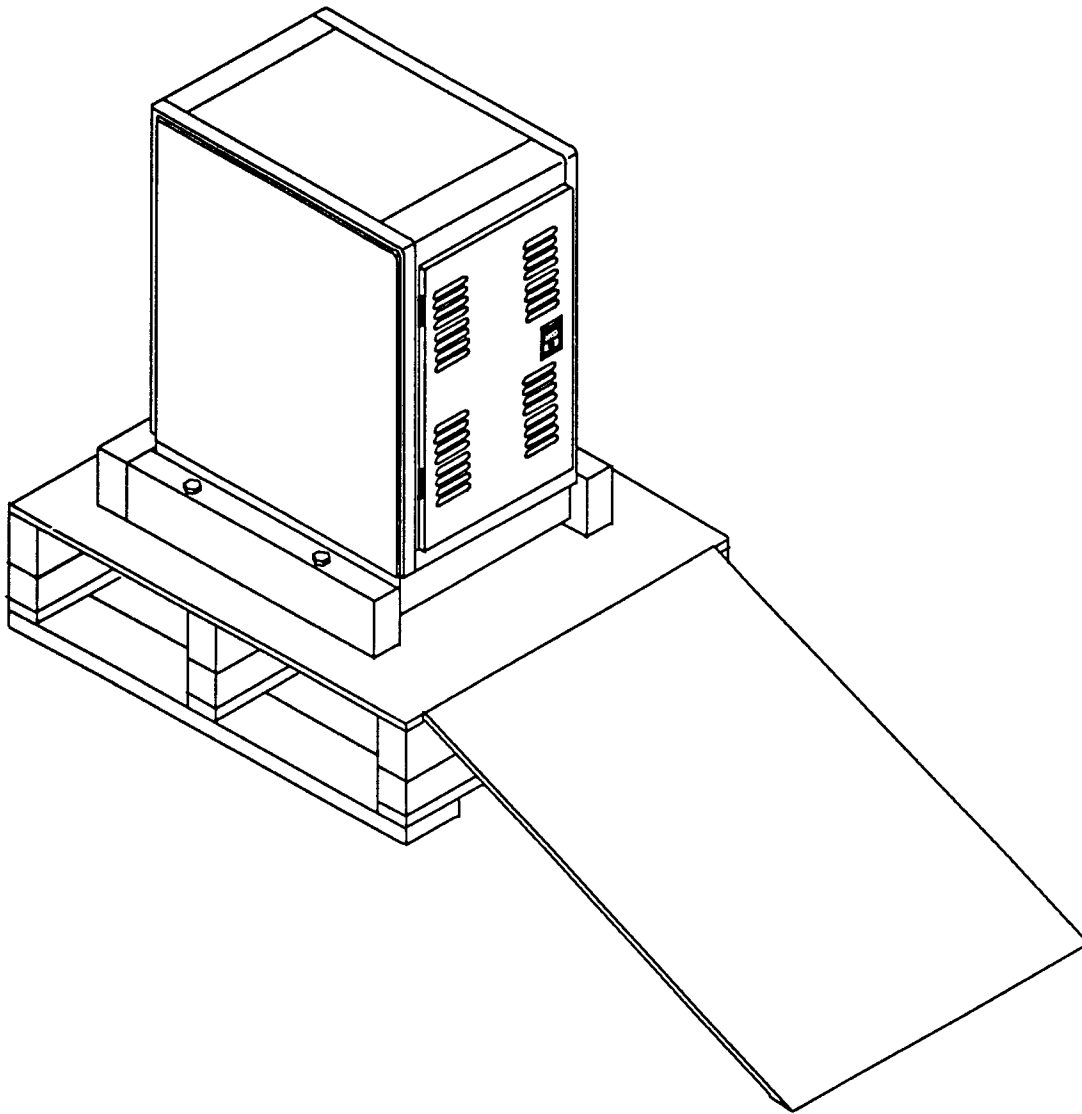

Positioning Ramp on Pallet

EP005018

10) With the assistance of a second person, carefully roll the LF 6602 down the ramp.

WARNING



To prevent personal injury, you must have a second person help you roll the LF 6602 down the ramp.

When the unit is being rolled down the ramp, ensure that it is tilted no more than 10 degrees in the vertical position. The LF 6602 weighs more than 181 kg (400 lbs). If the unit is tilted more than 10 degrees, it can topple over, causing personal injury.

- 11) Re-install the front panel onto the LF 6602.
- 12) Carefully roll the LF 6602 to the selected operating site.

NOTE

Retain and store all fastening hardware and packing materials, including the wooden ramp.

- 13) Open the drives' media access doors and remove the small foam blocks. Manually move the shuttles all the way to the right to the home position, as shown in the next figure.

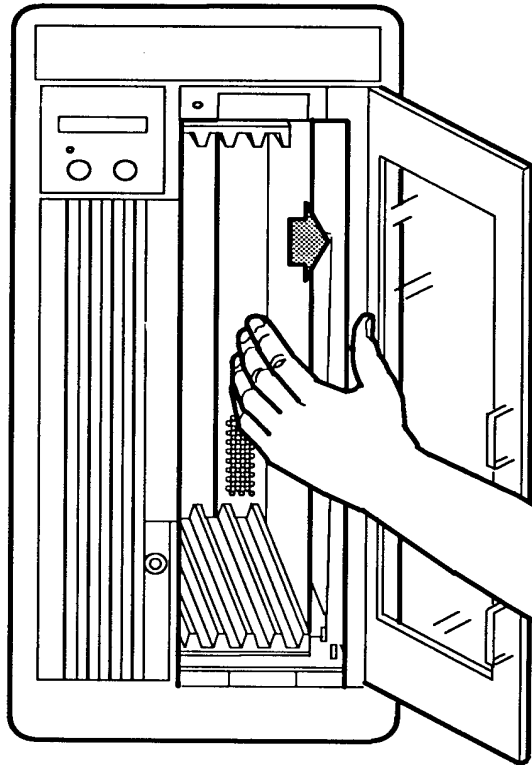

Moving the Shuttle to the Home Position

EP006042A

INSPECTING THE LF 6602

The following items should be included in the LF 6602 carton:

- One LF 6602
- One daisy chain SCSI cable
- One primary AC cord
- One User Manual
- One Manual Release Tool

Accessories such as a SCSI terminator, a SCSI cable and optional LM 6000 media cartridges, if ordered, will accompany the LF 6602 in a separate carton.

After unpacking the LF 6602, check for:

- damage to the cabinet
- dislocated or broken controls and indicators

Report all discrepancies, missing items and damaged equipment to your supplier. If condensation exists on the drive, allow the moisture to evaporate by exposing the LF 6602 to the operating environment for at least 6 hrs before powering on the unit.

REPACKING THE LF 6602

The LF 6602 should be repacked using the original packing materials. Close the baseplates of each drive before repacking the LF 6602 as explained in step 2) of the following procedure.

CAUTION



Shipping the LF 6602 without closing the drives' baseplates may result in damage to the drives which is not covered under warranty.

- 1) Ensure that the media cartridge is unloaded from the drive into the shuttle. Remove all cartridges from the shuttle.
- 2) On each drive's DOC, select the "Park Drive" option, as explained in the Viewing Diagnostic section, to prepare the LF 6602 for shipment.

If the drive is not functional, follow these steps to manually close the baseplates:

- a.) Ensure that the primary AC power cord is disconnected from the wall outlet and that the power switch on each drive is set to the OFF position (O).
- b.) With a T-15 screwdriver, loosen the four screws that secure the shipping bracket to the LF 6602 chassis (see next figure).

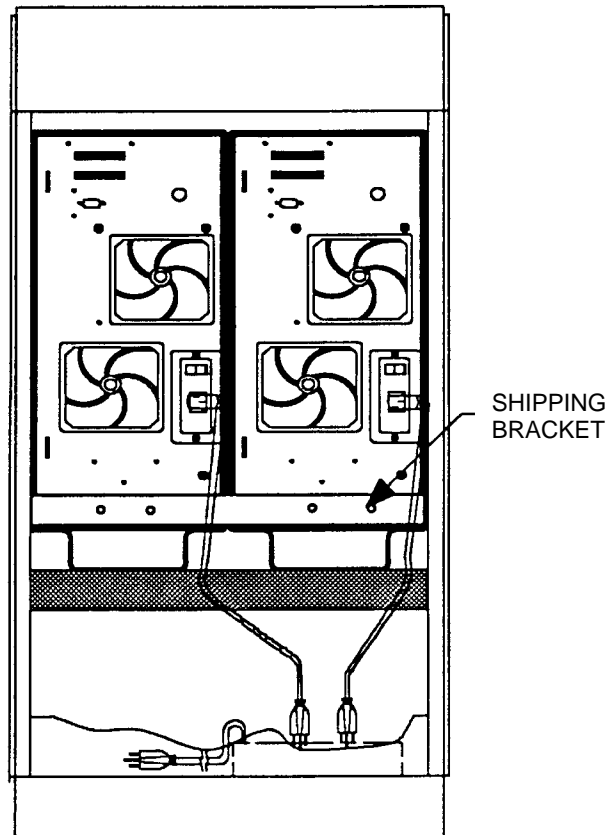

Shipping Bracket on Rear of LF 6602 Cabinet

EP006031A

c.) At the rear panel of each drive, insert the manual release tool into the upper access hole and engage the recessed D-shaped shaft. Turn the tool handle clockwise as far as it will turn, closing the upper baseplate.

d.) Repeat step c) at the lower manual release access hole to close the lower baseplate.

e.) Reposition the shipping bracket and secure it to the LF 6602 chassis by re-installing the four screws.

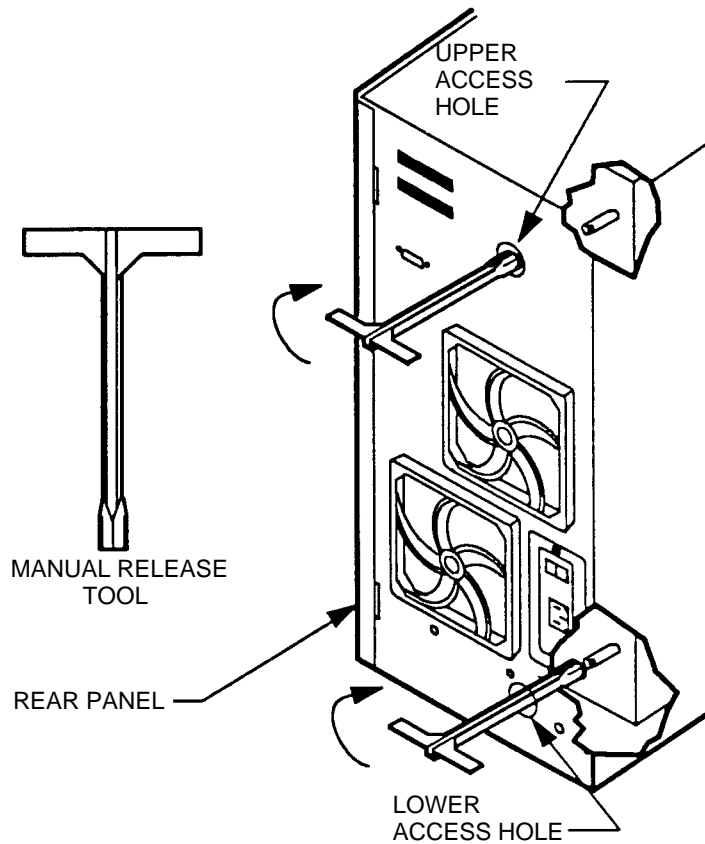

Manually Closing the Drive's Baseplates

EP006047

- 3) Ensure that the primary AC power cord is disconnected from the wall outlet and that the power switch on each drive is set to the OFF position (O).
- 4) Open each drive's media access door. Manually push each shuttle all the way to the left as shown in the next figure and insert the small foam shipping blocks to hold the shuttle in place. Close each media access door.

NOTE

If a media access door is locked, refer to the Removing the Bezel procedure to manually override the door lock solenoid.

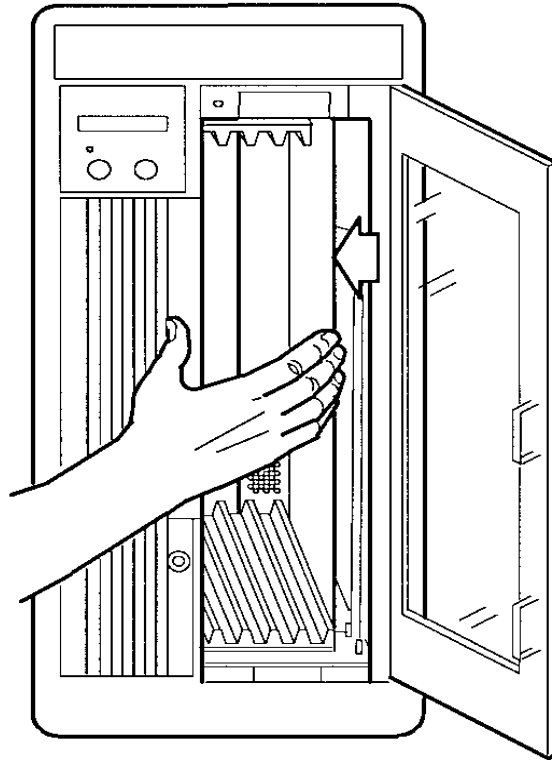

Moving the Shuttle Assembly to the Shipping Position

EP006041A

WARNING



Do not attempt to lift the LF 6602 without using proper equipment.

- 5) Position the ramp on the front lip of the pallet.
- 6) With the assistance of a second person, carefully roll the LF 6602 up the ramp.

WARNING



To prevent personal injury, you must have the assistance of a second person to help roll the LF 6602 up the ramp.

When the LF 6602 is being rolled up the ramp, ensure that the unit is tilted no more than 10 degrees in the vertical position. The LF 6602 weighs more than 181 kg (400 lbs). If the unit is tilted more than 10 degrees, it can topple over, causing personal injury.

- 7) After the LF 6602 is positioned on the pallet, remove the ramp.
- 8) Press in on that part of the frame (on the front) which is angled out and re-install the bolts.
- 9) Tighten the two bolts on the front of the frame.
- 10) Latch and lock the LF 6602's rear door.
- 11) Re-install the wood support, the two brackets and the four screws on each bracket on the front of the frame. With the #2 cross recess screwdriver, tighten the four screws.
- 12) Tighten the two bolts on the back of the frame.
- 13) Re-install new banding straps around the unit, placing the plastic pieces on the corners.
- 14) Place the protective bag over the LF 6602.
- 15) Position the foam cushion and ramp on top of the LF 6602. Place the shipping carton over the foam cushion, the ramp and the unit.
- 16) Re-install new banding straps around the shipping carton, placing the plastic pieces on the corners.

INSTALLATION REQUIREMENTS

The LF 6602 is shipped as a complete assembly, ready for cable connection and power up. No tools are required for the basic installation.

CAUTION



Remove the foam shipping block from each of the shuttle assemblies before powering on the LF 6600 drives.

Ensure that the internal temperature within the cabinet does not exceed the operating limits as described in the Product Specification (P/N 97653977) and this document.

The LF 6602 must be connected to a power distribution system that has a direct connection to earth ground (Terminated Terra [TT] network/ground connected). This unit is not suitable for use on a floating ground (Interrupted Terra [IT] network). Ensure the drive is connected to a power distribution system with an adequate current-handling capacity.

Before you install the LF 6602, provide for the clearances as listed in the table below to ensure that future servicing can be performed safely and to properly ventilate the LF 6602. Clearances are also necessary to provide operator access to the DOC panels and to the media access doors for loading and unloading media.

Operational Clearances for LF 6602

AREA	CLEARANCE
Front	51 cm (20 in)
Rear	51 cm (20 in)
Sides	12.7 cm (5 in)

Ensure that the site selected for the LF 6602 is able to support a volumetric air flow of 6.4 m³/min (224 cfm). Also, ensure that the operating environment is free from dust and particulates, such as tobacco smoke.

WARNING



To prevent fire or shock hazard, do not expose the LF 6602 to rain or moisture. Refer servicing to qualified technicians.

In case of fire or other emergency, isolate the units from the main power by disconnecting the power plugs from their site power receptacles. In situations where disconnecting the plugs is not possible or practical, disconnect the system main power to isolate the units from the main power.

Use of controls or adjustments, or performance of procedures other than those specified herein may result in exposure to hazardous laser radiation.

Do not stare directly into the laser beam or its reflection on any reflecting mirror-like surface. Invisible laser radiation can be emitted if the unit is open and safety interlocks are defeated.

SCSI BUS CONSIDERATIONS

Because the SCSI bus is limited to eight devices including the host, a maximum of three LF 6602's can be connected to a host computer in a series configuration using the appropriate SCSI controller and cable options.

The length of the SCSI interface cables used to interconnect the LF 6602 with other SCSI devices is dictated by the type of SCSI controller installed in each LF 6600 drive.

When the single-ended interface controller is used on all SCSI devices, the total length of the SCSI interface cable cannot exceed 6 m (19.5 ft). (Plasmon LMS does not recommend single-ended fast synchronous.) When a differential interface controller is used on all SCSI devices, the total SCSI interface cable length cannot exceed 25 m (82 ft).

NOTE

The internal SCSI cable for each LF 6600 is approximately 120 mm (4.8 in.). The SCSI cable connecting the LF 6600's is 105 cm (3 1/2 ft). These distances must be considered as part of the total SCSI cable length.

No stub connections are permitted.

The SCSI interface cabling used to interconnect an LF 6602 to a host can be daisy chained between SCSI devices as illustrated in the next figure. One interface cable is required to interface each pair of SCSI devices.

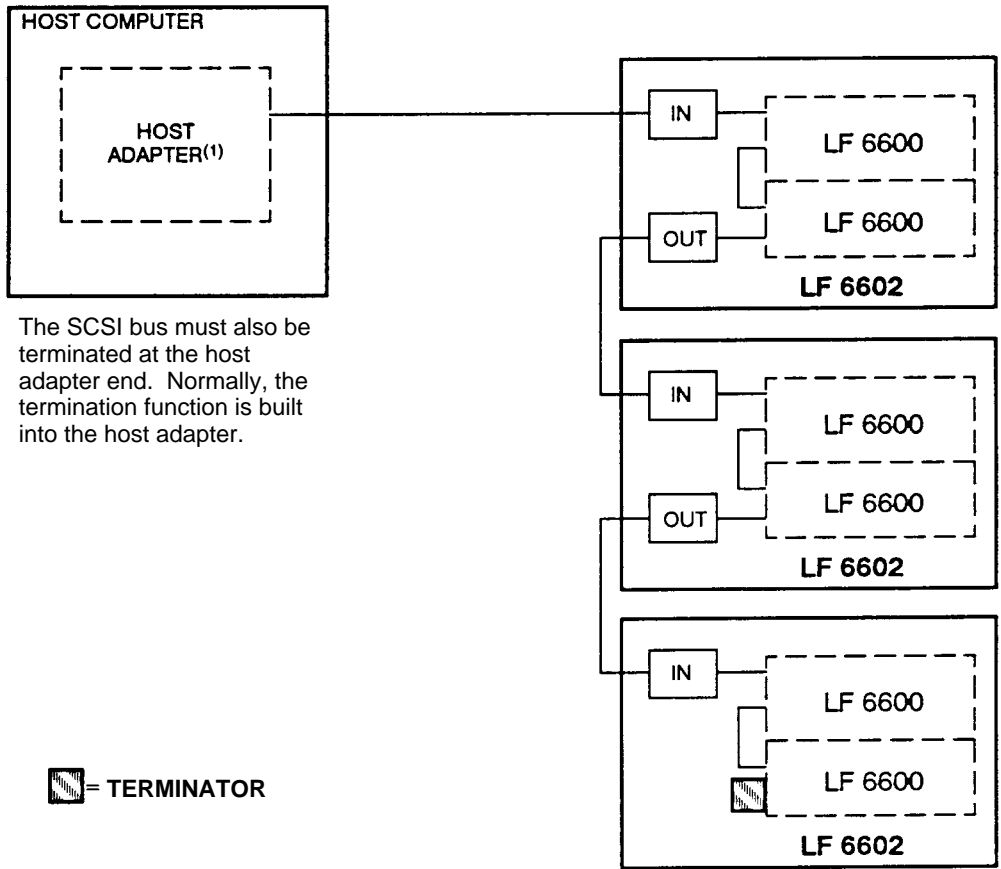

Host-to-LF 6602 Daisy Chain Cable Connections

EP006089

A terminator must always be installed on the vacant connector of the last SCSI device in the SCSI bus. The SCSI bus must always be terminated externally on the rear panel of an LF 6600 when an LF 6602 is the last SCSI device on the bus.

NOTE

You must first determine the type of termination your host system requires (see the [Accessories section](#) of this manual).

In a daisy chain configuration, a terminator must be used on both the first and last devices on the bus. One of these devices may be the host adapter.

All other LF 6602's between the first and last device in the daisy chain should not be terminated.

NOTE

Installation of both an active single-ended terminator and a passive single-ended terminator on the same bus is not recommended.

If only one LF 6602 is attached to a host, the bus must be terminated at the host adapter and the LF 6602 host computer (refer to the next figure).

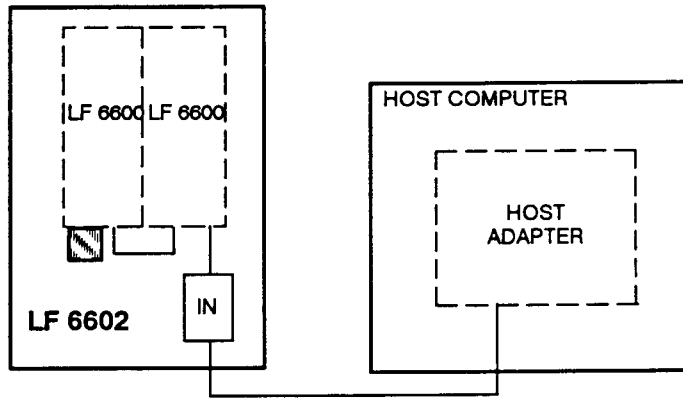

 = TERMINATOR

LF 6602-to-Host Cable Connection

EP006090

Normally, the termination function is built into the host adapter. Power for the external terminator is supplied by each LF 6600 and may also be supplied by another device in the SCSI daisy chain.

Refer to the [Accessories section](#) of this manual for a list of SCSI bus terminators, cables and their Plasmon LMS part numbers.

CONNECTING POWER AND SCSI CABLING

After the LF 6602 has been installed in its operating location, the primary AC power cord and host SCSI interface cabling can be connected. The type of primary AC power cord being installed depends upon the installation location.

Perform the following procedure to install the power cabling on an LF 6602:

- 1) Unlock and open the LF 6602's rear door.
- 2) Ensure that each drive's AC power cord is securely connected to the power socket strip (see figure below).

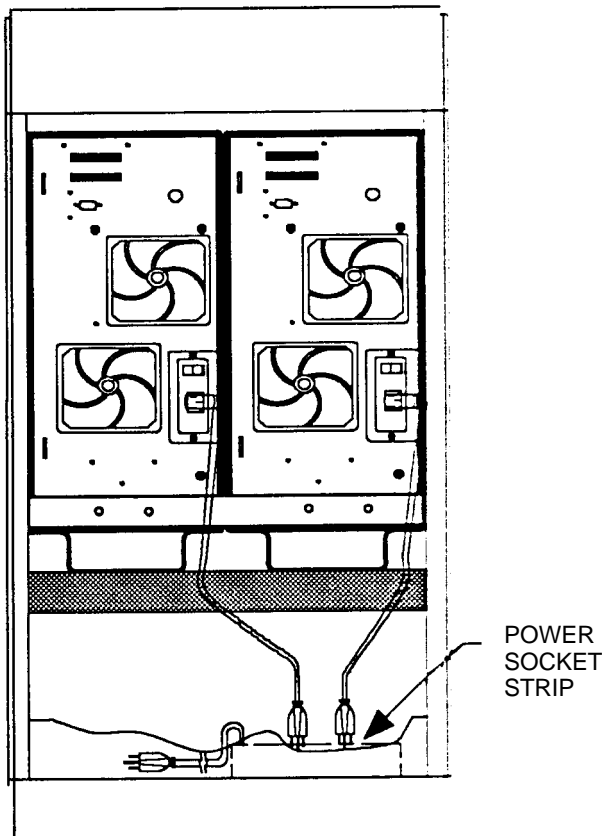

LF 6602 Rear Panel

EP006031

- 3) Ensure facility power is available and the primary AC power cord connector (male end) will match the site AC power wall outlet.
- 4) Ensure that the AC power switches on the drives' rear panels are set to the OFF (O) position.
- 5) Plug the primary AC power cord connector (female end) into the LF 6602's power strip.

Each drive has two SCSI connectors on the rear panel that are used to interface the drive with other SCSI devices (see the next figure). The lower SCSI I/O connector is normally used as the input port and the upper connector is used as the output port.

When only one LF 6602 is being interconnected with a host, one of the SCSI interface cables is connected to the lower connector of the first drive. A terminator is connected to the lower connector of the second drive to terminate the bus when the LF 6602 is the last or only SCSI device on a SCSI bus.

SINGLE-DEVICE CONFIGURATION

To connect SCSI cables and a terminator on a single LF 6602:

- 1) Plug one end of the SCSI interface cable into the vacant SCSI interface connector on the host.
- 2) Route the other end of the SCSI interface cable from the host, under the LF 6602's cabinet and up to the lower connector of the first drive. Install the cable into that connector.
- 3) Ensure that the shorter Plasmon LMS-supplied SCSI cable connecting the two drives is securely fastened to the connectors. This cable connects from the first drive's upper connector to the second drive's upper connector.
- 4) Install a SCSI terminator into the lower connector of the second drive.

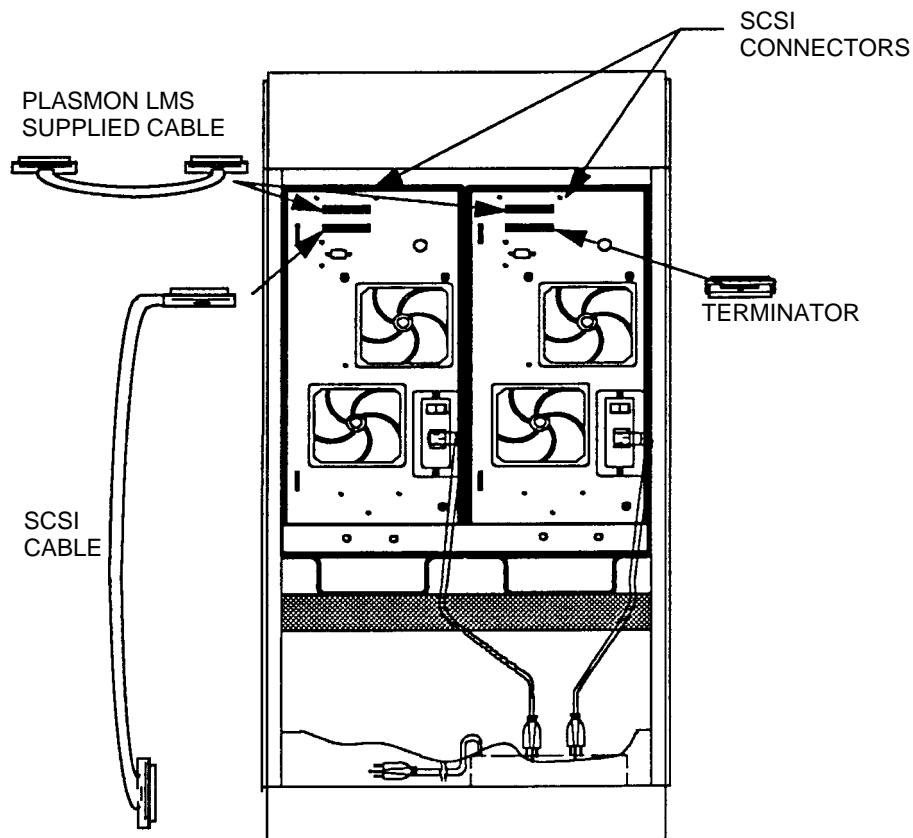

SCSI Cable and Terminator Configuration for the LF 6602

EP006084

MULTIPLE-DEVICE CONFIGURATION

To connect SCSI cables and a terminator, if necessary, in a multiple LF 6602 configuration, refer to the Single Device Configuration section and connect the SCSI cables according to steps 1 through 3).

If the LF 6602 is part of a daisy chain configuration and is not the last unit in the chain, install one end of a SCSI interface cable into the lower connector of the second drive and then install the other end of the cable into the connector of the next device in the chain. Repeat this process until you reach the last SCSI device in the daisy chain.

A terminator must be installed on the second drive's lower connector of the last LF 6602 in a daisy chain.

The SCSI bus must also be terminated at the host adapter when the host occupies the last position on the bus.

Power for the external terminators can also be supplied by either drive in the LF 6602 cabinet or another device in the SCSI daisy chain. It is very important that the SCSI bus is terminated at both ends in accordance with the LD 6100/LF 6600/LF 6602 SCSI Specification (P/N 97653978).

CONNECTOR VERIFICATION

Prior to powering on the system:

- 1) Verify proper termination at the host adapter, if applicable.
- 2) Verify proper termination at the last LF 6602 on the bus, if applicable.

CAUTION



Ensure that the foam shipping blocks have been removed from the shuttle assemblies before powering on the drives.

Refer to the Operating Instruction section in this manual for the power-on procedure.

EXTENSION PROCEDURES

If, during installation, you need to extend and access a drive through the front of the LF 6602:

- 1) Using a T-15 screwdriver, loosen the shipping bracket from the rear of the LF 6602 by unfastening the four screws that secure the shipping bracket to the LF 6602 chassis (see figure below).

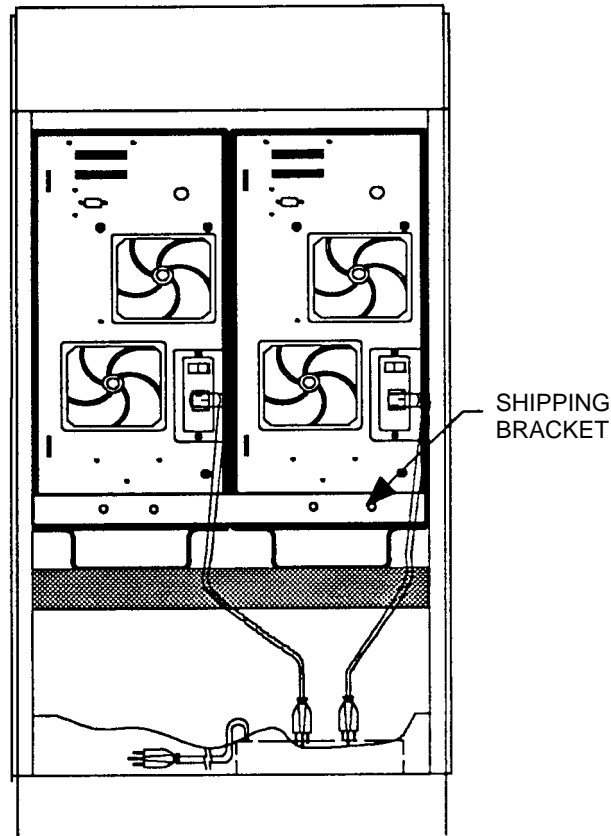

Location of Shipping Bracket on Rear of LF 6602 Cabinet

EP006031A

- 2) Pull off the cabinet's trim panel (see next figure).
- 3) Press down on the front release levers of one drive's rack mount slide and pull the drive out, away from the cabinet.

An interlock is incorporated into the design of the LF 6602's front panel to allow the extension of only one drive at a time (see the next figure). If the interlock is defeated and if both drives are extended simultaneously on their rack mount slides, the cabinet will become unbalanced and will topple over.

WARNING



Do not defeat the LF 6602's interlock and do not extend both drives simultaneously.

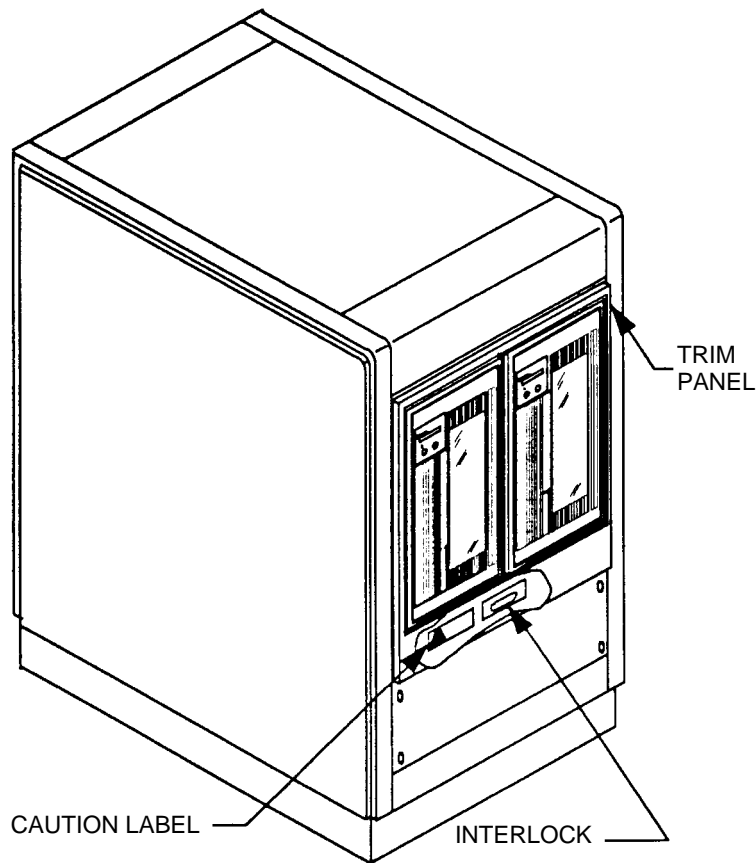

LF 6602 Cabinet Configuration Showing Interlock Location

EP006083

- 4) After you have finished, return the extended drive to its original position in the cabinet; remount the shipping bracket on the rear of the cabinet and secure the bracket by re-installing the four screws.
- 5) Re-install the cabinet's trim panel.

OPERATING INSTRUCTIONS

CONTROLS AND INDICATORS

The Drive Operator Console (DOC) for each drive is located on the front panel of the LF 6602. The DOC provides the controls and indicators that enable a user to operate each LF 6600.

The DOC controls and indicators consist of an alphanumeric display, a LOAD/MENU switch, a TEST/SELECT switch, and a WRITE PROTECT indicator. For a description of the DOC controls and indicator refer to the next table.

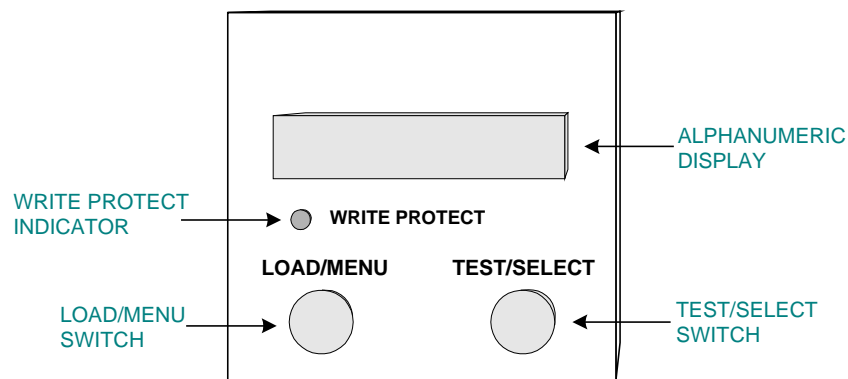

Drive Operator Console (DOC)

NOTE

Throughout this section, display messages are shown in English, the default language. However, Operating mode messages can appear in French or German (refer to the Operating Mode section of this manual). Configuration messages will always appear in English.

DOC Controls and Indicator for each Drive

CONTROL/ INDICATOR	TYPE	PURPOSE/FUNCTION
Alphanumeric Display	12 - Character Dot Matrix	Displays operating, configuration and test status messages.
LOAD/MENU Switch	Dual Function Push - Button Switch	In operating mode, the LOAD/MENU switch controls the loading and unloading of media cartridges. In Configuration mode, the LOAD/MENU switch steps through the menu of configurable parameters.
TEST/SELECT Switch	Dual Function Push - Button Switch	In operating mode, the TEST/SELECT switch invokes the diagnostic selftest. In Configuration mode, the TEST/SELECT switch scrolls through the options available for each configurable parameter.
WRITE PROTECT Indicator	Light Emitting Diode	The WRITE PROTECT indicator illuminates when either the Write Protect (WRT PROT) configuration option is enabled or a media cartridge WRITE PROTECT switch is locked (write disabled). The WRITE PROTECT indicator will flash when an RTPM condition occurs. Also, the WRITE PROTECT indicator will flash when the drive or the media is in a read only condition.

POWER-ON PROCEDURE

Perform the following procedure to power on each LF 6600:

- 1) Ensure that the LF 6600 is properly connected ([refer to the SCSI Bus Consideration section](#)).
- 2) Refer to the Media Insertion and Removal section and insert a cartridge into slot 1. If slot 1 is empty, the LF 6600 will display "1 Empty" on the DOC shortly after initial power on.

NOTE

Slot 1 is the factory setting for the media autoload configuration option.

If this option has been changed by the user, all references to slot 1 in this manual apply instead to the slot number selected in the autoload configuration option. Refer to the Configuration mode section for more information on setting configuration options.

- 3) Set the AC Power Switch to the ON (I) position and verify that air is flowing through the LF 6600.
- 4) Verify that the WRITE PROTECT indicator is illuminated briefly.
- 5) Verify that the "Selftest" message is displayed on the DOC.

The "Selftest" message indicates that the power-on selftests are running. When the power-on selftests are completed without errors, the drive will perform a test to determine which slots in the shuttle are occupied by media cartridges and then will load media #1.

When the "1 Ready" message is displayed, the LF 6600 has passed the power-on selftests and has successfully loaded the LM 6000 media cartridge in slot 1.

- 6) Verify that the "Selftest" message displayed on the DOC is replaced by the "1 Ready" message.
- 7) Refer to Modes of Operation section to familiarize yourself with the LF 6600 modes of operation. View the current drive configuration parameters by following the procedure in Viewing the Configuration section. The factory settings can be changed to custom settings of your choice by following the instructions provided in the Configuration Mode section.

The LF 6600 is now in the normal Operating mode, and is ready to be controlled and accessed by a host system.

MODES OF OPERATION

The LF 6600 has three modes of operation that are selectable from the DOC:

- Operating Mode
- Configuration Mode
- Test Mode

In Operating mode the host system can read and write data, and select and load media cartridges. In Configuration mode an operator can view a menu of parameters and select options for each parameter. Test mode invokes drive diagnostics to verify proper drive operation.

OPERATING MODE

The LF 6600 enters the Operating mode after being powered on and displays the "# Ready" message on the DOC. The DOC will display the appropriate messages listed in the table below during normal operation.

To enter Operating mode if the drive is in Test mode, wait until the tests are completed and then press the LOAD/MENU switch. To enter Operating mode if the drive is in Configuration mode, press the LOAD/MENU and the TEST/SELECT switches simultaneously.

NOTE

The pound symbol #, shown in the table below, designates the slot number.

NOTE

The pound symbol #, shown in the table below, designates the slot number.

LF 6600 DOC Operating Mode Messages

OPERATING CONDITION	DOC DISPLAY (ENGLISH)	DOC DISPLAY (FRENCH)	DOC DISPLAY (GERMAN)
Inserting Cartridge #	Inserting #	Insere#	Einfügend
Loading Media #	Loading #	Charger #	Ladend #
Drive Ready (Cartridge # not Locked ⁽¹⁾)	# Ready	# Prêt	# Bereit
Drive Ready (Cartridge # Locked ¹)	Locked	Verrouillé	Gesperrt
Drive Reading Cartridge #	Reading #	Lecture #	Lesend #
Drive Writing Cartridge #	Writing #	Eriture #	Schreibend #
Unload Cartridge #	Unlodng #	Decharge #	Entladend #
Removing Cartridge	Removing #	Retir Disk #	Entfernend #
Moving to Cartridge #	Moving to #	Deplace #	Gehe Zu #
Cartridge # Positioned	# Positioned	Positione #	# In Pos
Shuttle in Home Position	Home	Origine	Ruheposition
Drive is in Rest	SCSI reset	SCSI Reinit	SCSI Reinit
Illegal Request (Spindown Disabled/ Door Locked)	Denied	Refuse	Abgelehnt
Drive is Testing Itself	Selftest	Autotest	Selbsttest
Drive is Scanning Media #	Scanning #	Scanning #	Media Prüf #
Insert Cartridge #	# Inserted	# Insere	# Eingelert
Shuttle is being Initialized	Init Shuttle	Init Shuttle	Shuttle Init
Slot # in Shuttle is Empty	# Empty	# Vide	# Leer
Door is Open	Door Open	Porte Ouvert	Türe Offen
Shuttle Moving to Home Position	Move to Home	Depl Origine	Zur Ruhepos

1 "Locked" means that the host has issued a PREVENT MEDIA REMOVAL command.

CONFIGURATION MODE

Configuration mode is used to view and set each of the LF 6600 drive operating parameters. The parameters that can be configured and displayed are summarized in the following (the corresponding DOC display is shown in parentheses).

Viewing the configuration ("View Config")

- View the current operating parameters ("View Current")
- View the firmware revisions of the drive ("View FW Revs")
- View the hardware revisions of the drive ("View HW S/Ns")
- View the hardware part numbers of the drive ("View HW P/Ns")

Setting the configuration of the operating parameters ("Set Config")

- Set all parameters to the default value ("Set Defaults")
- Set device SCSI identification number 0 through 7 ("SCSI ID:")
- Enable or disable parity checking ("Parity:")
- Set language option to English, French or German ("Language:")
- Enable or disable write protect option ("Wrt Prot:")
- Enable or disable media AutoLoad option ("AutoLoad:")
- Enable or disable load switch option ("Load SW:")
- Enable or disable read ahead ("Rd Ahead:")
- Enable or disable Controller Detected Error blink option ("CDE Curs:")
- Enable or disable Busy option ("Busy")
- Enable or disable Mode Select Read Ahead ("ModSel RA")
- Enable or disable Media Management Spin Up ("MM SpinUp")

Viewing diagnostic results or performing diagnostic operations ("Diagnostics")

- Park the drive in preparation for shipment ("Park Drive")
- Display the state of the drive sensors ("Test Sensors")
- Clear the drive initialization variables in nonvolatile memory ("Clear NvRAM")
- Allow Shuttle Calibration ("Cal Shuttle")
- Display controller detected error information ("View CDEs")
- Enable or disable system event logging ("Sys Log:")
- Set the extent of internal diagnostic test coverage ("Test Thru:")
- View Real Time Performance Monitor ("View RTPM")
- Clear RTPM error ("Clear RTPM")
- Initialize DPC ("Init DPC")

Set the internal drive serial number ("Set Serial #")

Configuration mode can be entered when the "Ready" message is displayed on the DOC. To enter the Configuration mode:

- 1) Press both the LOAD/MENU and TEST/SELECT switches simultaneously.
- 2) Verify that "View Config" is displayed.

Entry to Configuration mode starts with a [Main menu](#), allowing the user to select one of four submenus. The Main menu includes the following submenu options:

- | | |
|-----------------------|---|
| "View Config" | This is the entry point into the Configuration menu. Press the SELECT switch to enter a submenu allowing the user to view the drive operating parameters, firmware revisions and hardware serial numbers. Press the MENU switch to select the next option in the Main menu. |
| "Set Config" | Press the SELECT switch to enter a submenu allowing the user to select and set the drive operating parameters. Press the MENU switch to select the next option in the Main menu. |
| "Diagnostics" | Press the SELECT switch to enter a submenu allowing the user to display diagnostic parameters or perform diagnostic operations. Diagnostics includes the "Park Drive" option to prepare the drive for shipping. Press the MENU switch to select the next option in the Main menu. |
| "Set Serial #" | Press the SELECT switch to enter a submenu allowing the user to set the drive serial number. Press the MENU switch to select the next option in the Main menu, which will wrap back to the entry point of Configuration mode and display "View Config". |

NOTE

The serial number set in the drive must correspond to the last 5 digits of the drive's actual serial number for accurate internal event logging to occur. The drive's actual serial number is written on the back of the drive enclosure.

A structure diagram for the [Main menu](#) is shown in the next figure.

To move up a level in the Configuration menu hierarchy, press the LOAD/MENU and TEST/SELECT switches simultaneously.

To exit the Configuration mode, press the LOAD/MENU and TEST/SELECT switches simultaneously from the Main menu. The display will show the message which appeared prior to the drive entering the Configuration mode.

The "Ready" message is displayed when a media cartridge is loaded on the drive spindle.

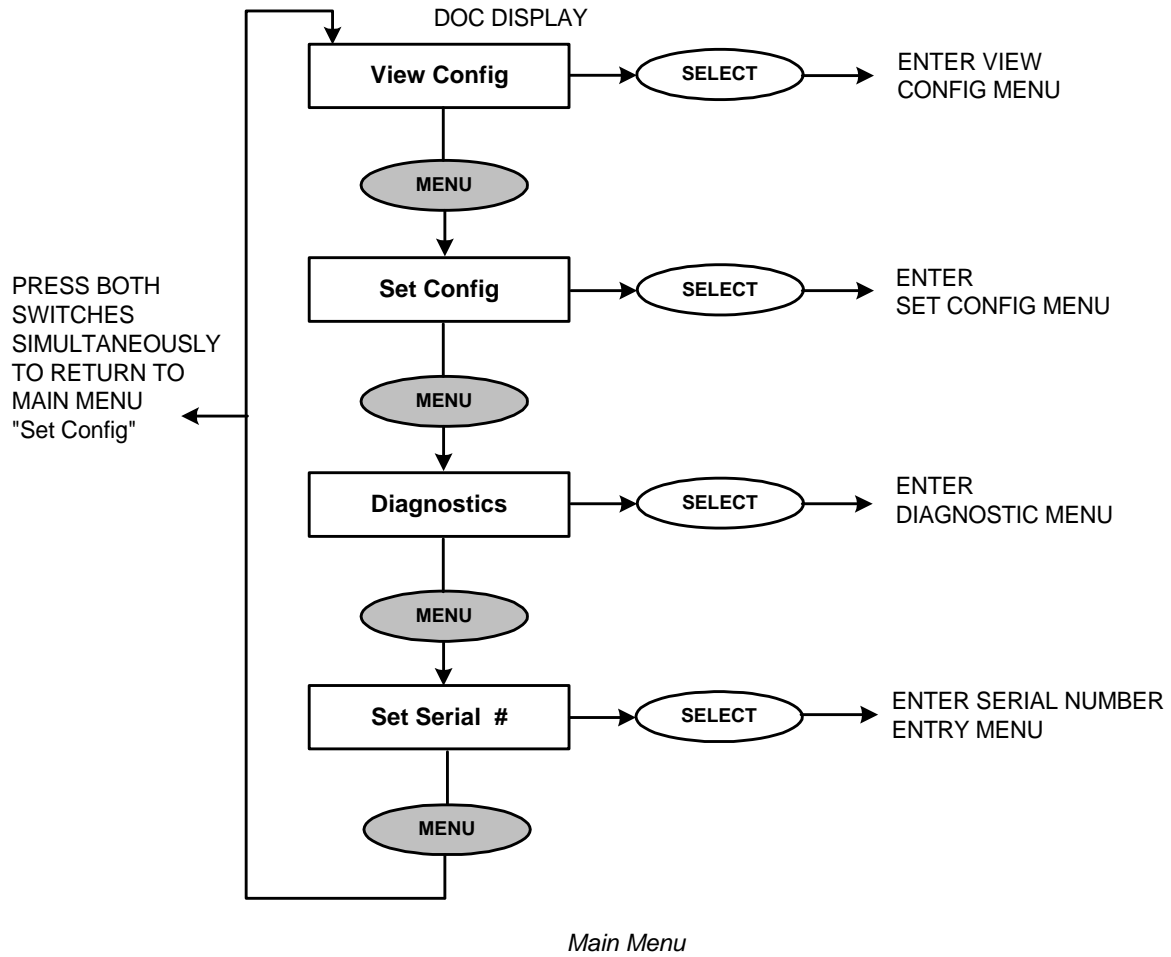

VIEWING THE CONFIGURATION ("VIEW CONFIG")

To view the configuration, press the TEST/SELECT switch while "View Config" is displayed in the Main menu. The drive will enter the View Configuration menu which includes the following options:

- "View Current"** Press the SELECT switch to display the current drive operating parameters. The operating parameters are listed in the table below. Press the MENU switch to select the next option in the View Configuration menu.
- "View FW Revs"** Press the SELECT switch to display the drive firmware revisions. These include firmware revisions for the DPC, Rws A, and Rws B and Woodi. Press the MENU switch to select the next option in the View Configuration menu.
- "View HW S/Ns"** Press the SELECT switch to display the serial numbers. These include serial numbers for the Drv SN, Woodi, Rws A, Rws B, Oma A, Oma B, and Dpc. Press the MENU switch to select the next option in the View Configuration menu.
- "View HW P/Ns"** Press the SELECT switch to display the hardware part numbers. These include part numbers for Woodi, Rws A, Rws B and Dpc. Press the MENU switch to select the next option in the View Configuration menu.

View Configuration Messages

OPTION NAME	CURRENT SETTING	DEFAULT FACTORY SETTING
SCSI ID:	# 0 - 7	0
Parity:	On or Off	On
Language:	Eng, Frh or Grm	Eng
Wrt Prot:	On or Off	Off
Auto Load:	Slot 1 - 6 or MRU	1
Load SW:	On or Off	On
Rd Ahead:	On or Off	Off
CDE Curs:	On or Off	Off
Busy	On or Off	On
ModSel RA	On or Off	On
MM SpinUp	On or Off	On

A structure diagram for the View Configuration menu is shown in the next figure.

To move up a level in the Configuration menu hierarchy to the Main menu, press the LOAD/MENU and TEST/SELECT switches simultaneously.

To exit the Configuration mode, press the LOAD/MENU and TEST/SELECT switches simultaneously from the Main menu. The display will show the message which appeared prior to the drive entering the Configuration mode.

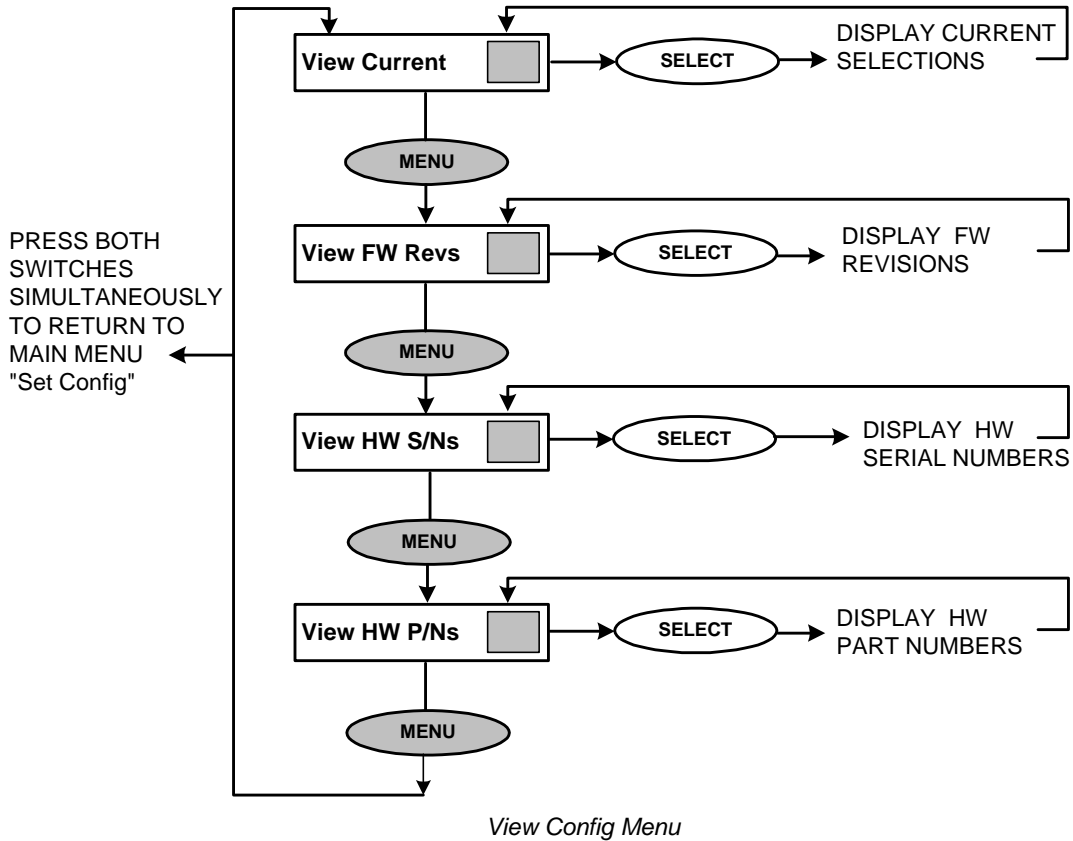

SETTING THE CONFIGURATION OF THE OPERATING PARAMETERS ("SET CONFIG")

To enter the mode to set the drive configuration, press the TEST/SELECT switch while "Set Config" is displayed in the Main menu. The drive will enter the Set Configuration menu which includes the following options:

- | | |
|-----------------------|---|
| "Set Defaults" | Press the SELECT switch to set all drive operating parameters to the factory defaults. Press the MENU switch to select the next option in the Set Configuration menu. |
| "SCSI ID:" | Press the SELECT switch to scroll through the possible SCSI ID values (0,1,2,3,4,5,6,7). When the desired ID value is displayed, press the MENU switch to enter that value as the SCSI ID and select the next option in the Set Configuration menu. |
| "Parity:" | Press the SELECT switch to turn parity checking on or off. SCSI bus parity generation is always enabled but SCSI bus parity checking by the drive may be turned on or off. When the desired state (on or off) is displayed, press the MENU switch to enter that state for parity checking and select the next option in the Set Configuration menu. |
| "Language:" | Press the SELECT switch to scroll through the language options (Eng = English, Frh = French, Grm = German) for the DOC operating messages. When the desired language option is displayed, press the MENU switch to enter that option and select the next option in the Set Configuration menu. |
| "Wrt Prot:" | Press the SELECT switch to turn write protect on or off. When the desired state (on or off) is displayed, press the MENU switch to enter that state for write protect and select the next option in the Set Configuration menu. |
| "AutoLoad:" | Press the SELECT switch to scroll through the Auto Load options. The drive can be configured to load the cartridge residing in a specific slot (1,2,3,4,5,6) or the Most Recently Used (MRU) cartridge. When the desired option (1,2,3,4,5,6,MRU) is displayed, press the MENU switch to enable that option and select the next option in the Set Configuration menu. |
| "Load SW:" | Press the SELECT switch to enable or disable the LOAD switch on the DOC. When the desired state (on or off) is displayed, press the MENU switch to enter that state for load switch and select the next option in the Set Configuration menu. |
| "Rd Ahead:" | Press the SELECT switch to turn read ahead on or off. When the desired state (on or off) is displayed, press the MENU switch to enter that state for read ahead and select the next option in the Set Configuration menu. |
| "CDE Curs:" | Press the SELECT switch to turn the CDE indicator (a blinking solid cursor in the rightmost display position) on or off. When the desired state (on or off) is displayed, press the MENU switch to enter that state for CDE Curs and select the next option in the Set Configuration Menu. |

- "Busy"** Press the SELECT switch to toggle the Busy option between On and Off. When the desired mode has been selected, press the LOAD/MENU switch to select the next option.
- "ModSel RA"** Press the SELECT switch to toggle the Mode Select Read Ahead option between On and Off. When the desired mode has been selected, press the LOAD/MENU switch to select the next option.
- "MM SpinUp"** Press the SELECT switch to toggle the Media Management Spin Up option between On and Off. When the desired mode has been selected, press the LOAD/MENU switch to select the next option.

A structure diagram for the Set Configuration menu is shown in the next figure.

To move up a level in the configuration menu hierarchy to the Main menu, press the LOAD/MENU and TEST/SELECT switches simultaneously.

To exit the Configuration mode, press the LOAD/MENU and TEST/SELECT switches simultaneously from the Main menu. The display will show the message which appeared prior to the drive entering the Configuration mode.

PRESS BOTH SWITCHES SIMULTANEOUSLY TO RETURN TO MAIN MENU "Set Config"

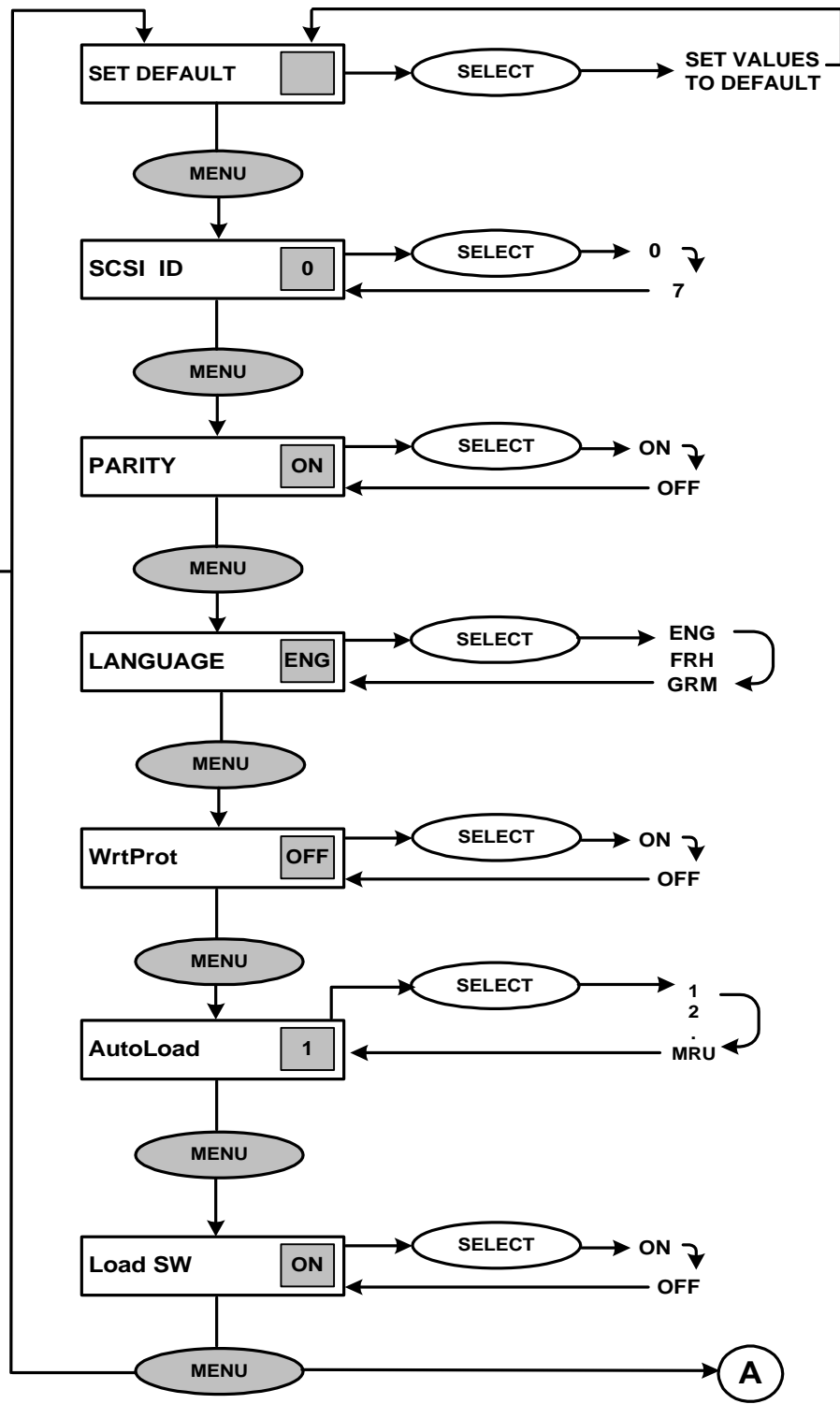

Set Config Menu (Part 1)

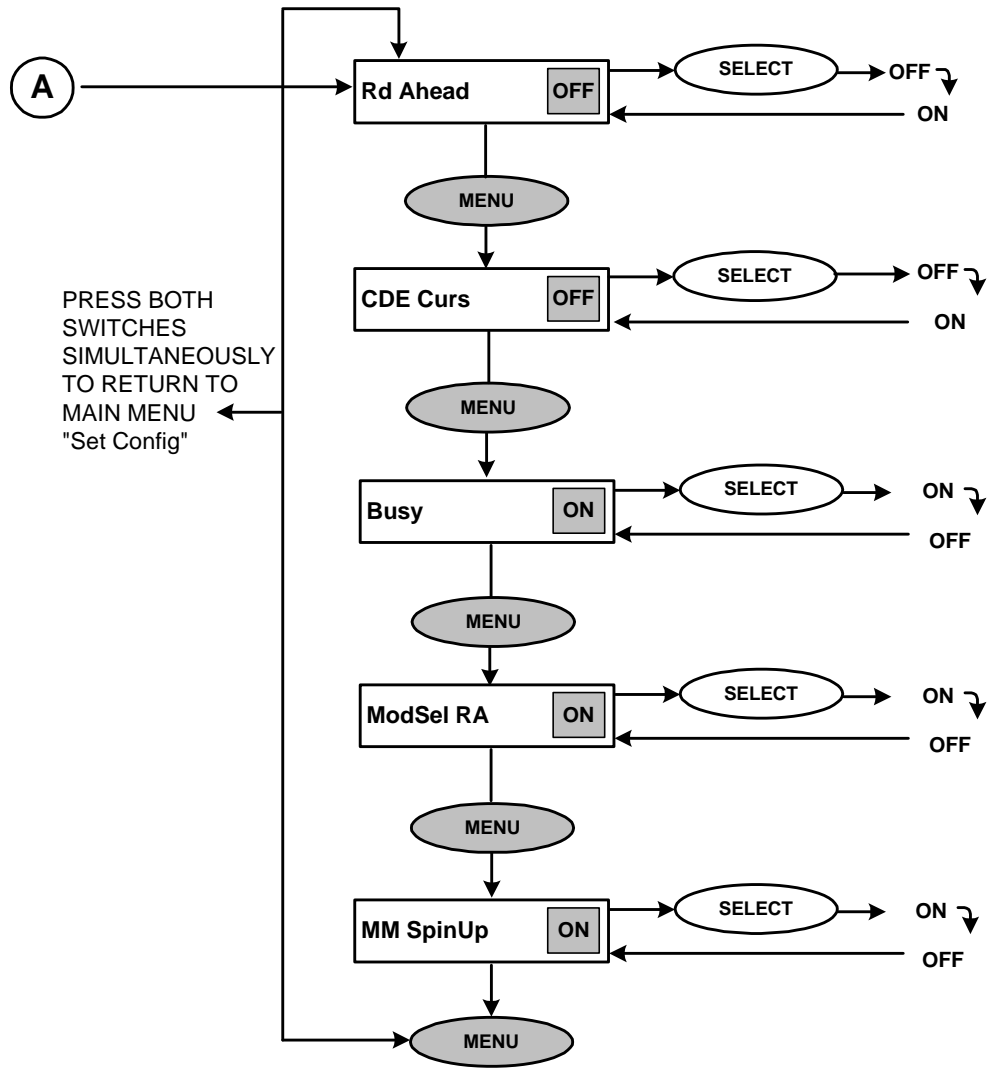

Set Config Menu (Part 2)

SETTING THE SCSI ID

The SCSI ID can be set to one of eight device Identification (ID) numbers (0 through 7); however, each device connected to the same SCSI bus must have a different SCSI ID.

Perform the following procedure to set the LF 6600's SCSI ID number:

- 1) Enter the Configuration mode by pressing both the LOAD/MENU and TEST/SELECT switches simultaneously.
- 2) Press the MENU switch until "Set Config" is displayed.
- 3) Press the SELECT switch to enter the Set Configuration menu.
- 4) Press the MENU switch until "SCSI ID" is displayed.
- 5) Press the SELECT switch to scroll through the options for the SCSI ID value (0,1,2,3,4,5,6,7). When the desired value is displayed for the SCSI ID, press MENU to enter the SCSI ID value and move to the next option in the Set Configuration menu.
- 6) Simultaneously press the LOAD/MENU and TEST/SELECT switches to exit the Configuration mode. Simultaneously press the LOAD/MENU and TEST/SELECT Switches again to move up to the Main menu.

NOTE

After resetting the device ID, turn the drive off, wait 1 sec and then turn the drive on again. This ensures that the new device ID will be acknowledged by the SCSI bus.

SETTING THE BUS PARITY CHECKING

SCSI bus parity generation is always enabled; however, SCSI bus parity checking at the drive can be disabled.

Perform the following procedure to turn parity checking on or off.

- 1) Enter the Configuration mode by pressing both the LOAD/MENU and TEST/SELECT switches simultaneously.
- 2) Press the MENU switch until "Set Config" is displayed.
- 3) Press the SELECT switch to enter the Set Configuration menu.
- 4) Press the MENU switch until "Parity:" is displayed.
- 5) Press the SELECT switch to scroll through the states for parity checking (on, off) When the desired state is displayed, press MENU to enter the state and move to the next option in the Set Configuration menu.
- 6) Simultaneously press the LOAD/MENU and TEST/SELECT switches to exit the Configuration mode. Simultaneously press the LOAD/MENU and TEST/SELECT Switches again to move up to the Main menu.

SETTING THE LANGUAGE

The language option enables the user to select the language used by the LF 6600 to display messages in the Operating mode. (English is the only available language for Configuration mode.)

Perform the following procedure to set the operating mode display language.

- 1) Enter the Configuration mode by pressing both the LOAD/MENU and TEST/SELECT switches simultaneously.
- 2) Press the MENU switch until "Set Config" is displayed.
- 3) Press the SELECT switch to enter the Set Configuration menu.
- 4) Press the MENU switch until "Language:" is displayed.
- 5) Press the SELECT switch to scroll through the language display options (Eng = English, Frh = French, Grm = German). When the desired language option is displayed, press MENU to enter the language option and move to the next option in the Set Configuration menu.
- 6) Simultaneously press the LOAD/MENU and TEST/SELECT switches to exit the Configuration mode. Simultaneously press the LOAD/MENU and TEST/SELECT Switches again to move up to the Main menu.

SETTING THE WRITE PROTECT OPTION

The write protect option enables the user to inhibit the LF 6600 from writing to any media inserted into the drive, regardless of the write protect setting on the media cartridges.

Perform the following procedure to turn write protect on or off.

- 1) Enter the Configuration mode by pressing both the LOAD/MENU and TEST/SELECT switches simultaneously.
- 2) Press the MENU switch until "Set Config" is displayed.
- 3) Press the SELECT switch to enter the Set Configuration menu.
- 4) Press the MENU switch until "Wrt Prot:" is displayed.
- 5) Press the SELECT switch to scroll through the states for write protect (on, off). When the desired state is displayed, press MENU to enter the state and move to the next option in the Set Configuration menu.
- 6) Simultaneously press the LOAD/MENU and TEST/SELECT switches to exit the Configuration mode. Simultaneously press the LOAD/MENU and TEST/SELECT Switches again to move up to the Main menu.

NOTE

The Write Protect indicator on the DOC is illuminated when write protect is enabled.

SETTING THE MEDIA AUTOLOAD OPTION

The media AutoLoad load option enables a user to choose which media cartridge is automatically inserted and loaded at power up and whenever the LOAD/MENU switch is pressed while in the Operating mode. The factory default selects the cartridge in slot 1.

Perform the following procedure to set the LF 6600's AutoLoad option:

- 1) Enter the Configuration mode by pressing both the LOAD/MENU and TEST/SELECT switches simultaneously.
- 2) Press the MENU switch until "Set Config" is displayed.
- 3) Press the SELECT switch to enter the Set Configuration menu.
- 4) Press the MENU switch until "AutoLoad:" is displayed.
- 5) Press the SELECT switch to scroll through the autoload options, (1,2,3,4,5,6,and MRU). When the desired option is displayed, press MENU to enable that option and to move to the next option in the Set Configuration menu.
- 6) Simultaneously press the LOAD/MENU and TEST/SELECT switches to exit the Configuration mode. Simultaneously press the LOAD/MENU and TEST/SELECT Switches again to move up to the Main menu.

SETTING THE LOAD SWITCH OPTION

The load switch option enables the user to enable or disable the LOAD/MENU switch on the DOC. The LOAD/MENU switch can be disabled to prevent accidentally spinning down a media cartridge. This also prevents cartridge loading from the DOC, giving the host exclusive control of media loading.

Perform the following procedure to enable or disable the LOAD/MENU switch.

- 1) Enter the Configuration mode by pressing both the LOAD/MENU and TEST/SELECT switches simultaneously.
- 2) Press the MENU switch until "Set Config" is displayed.
- 3) Press the SELECT switch to enter the Set Configuration menu.
- 4) Press the MENU switch until "Load SW:" is displayed.
- 5) Press the SELECT switch to scroll through the states for the load switch (on, off). When the desired state is displayed, press MENU to enter the state and move to the next option in the Set Configuration menu.
- 6) Simultaneously press the LOAD/MENU and TEST/SELECT switches to exit the Configuration mode. Simultaneously press the LOAD/MENU and TEST/SELECT Switches again to move up to the Main menu.

SETTING THE READ AHEAD OPTION

The read ahead option often improves the overall read data transfer rate of the LF 6600 in applications which require continuous blocks of data to be read (as compared to the same subsystem without read ahead).

Perform the following procedure to turn read ahead on or off.

- 1) Enter the Configuration mode by pressing both the LOAD/MENU and TEST/SELECT switches simultaneously.
- 2) Press the MENU switch until "Set Config" is displayed.
- 3) Press the SELECT switch to enter the Set Configuration menu.
- 4) Press the MENU switch until "Rd Ahead:" is displayed.
- 5) Press the SELECT switch to scroll through the states for read ahead (on, off). When the desired state is displayed, press MENU to enter the state and move to the next option in the Set Configuration menu.
- 6) Simultaneously press the LOAD/MENU and TEST/SELECT switches to exit the Configuration mode. Simultaneously press the LOAD/MENU and TEST/SELECT Switches again to move up to the Main menu.

CAUTION



The read ahead option is system dependent. Ensure that you check with your system analyst before setting this option.

When enabled, the read ahead option uses the data buffer (2 MBytes) to store data sectors read from the disk beyond those sectors requested by the host. Subsequent sequential sectors will be read directly from the buffer instead of incurring the latency time it takes to access sequential sectors. (Refer to the LD 6100/LF 6600 SCSI Interface Specification [P/N 97653978].)

SETTING THE CDE CURS OPTION

The CDE Curs (Controller Detected Error) option enables a blinking solid cursor in the rightmost character location of the DOC panel when a CDE has occurred. In most system installations, the host system will recover from reported CDE's and no user intervention is required. A developer may wish to enable this indicator during system development or installation.

Perform the following procedure to turn CDE Curs on or off.

- 1) Enter the Configuration mode by pressing both the LOAD/MENU and TEST/SELECT switches simultaneously.
- 2) Press the MENU switch until "Set Config" is displayed.
- 3) Press the SELECT switch to enter the Set Configuration menu.
- 4) Press the MENU switch until "CDE Curs:" is displayed.

- 5) Press the SELECT switch to scroll through the states for CDE Curs (on, off). When the desired state is displayed, press MENU to enter the state and move to the next option in the Set Configuration menu.
- 6) Simultaneously press the LOAD/MENU and TEST/SELECT switches to exit the Configuration mode. Simultaneously press the LOAD/MENU and TEST/SELECT Switches again to move up to the Main menu.

SETTING THE BUSY OPTION

When the enabled, the "Busy" message is displayed at the DOC during a spin up or spin down operation. The "Busy" message will also be displayed when a command that cannot be stored for later execution is being executed.

Perform the following procedure to enable or disable the BUSY option.

- 1) Enter the Configuration mode by pressing both the LOAD/MENU and TEST/SELECT switches simultaneously.
- 2) Press the MENU switch until "Set Config" is displayed.
- 3) Press the SELECT switch to enter the Set Configuration menu.
- 4) Press the MENU switch until "Busy:" is displayed.
- 5) Press the SELECT switch to scroll through the states for the load switch (on, off). When the desired state is displayed, press MENU to enter the state and move to the next option in the Set Configuration menu.
- 6) Simultaneously press the LOAD/MENU and TEST/SELECT switches to exit the Configuration mode. Simultaneously press the LOAD/MENU and TEST/SELECT Switches again to move up to the Main menu.

SETTING THE MODSEL RA OPTION

When the enabled, the (Mode Select Read Ahead) ModSel RA option allows the LaserDrive to continue reading sequentially after a READ command has been completed.

Perform the following procedure to enable or disable the ModSel RA option.

- 1) Enter the Configuration mode by pressing both the LOAD/MENU and TEST/SELECT switches simultaneously.
- 2) Press the MENU switch until "Set Config" is displayed.
- 3) Press the SELECT switch to enter the Set Configuration menu.
- 4) Press the MENU switch until "ModSel RA:" is displayed.
- 5) Press the SELECT switch to scroll through the states for the load switch (on, off). When the desired state is displayed, press MENU to enter the state and move to the next option in the Set Configuration menu.
- 6) Simultaneously press the LOAD/MENU and TEST/SELECT switches to exit the Configuration mode. Simultaneously press the LOAD/MENU and TEST/SELECT Switches again to move up to the Main menu.

SETTING THE MM SPINUP OPTION

When the enabled, the (Media Management Spin Up) MM SpinUp option allows the LaserDrive to read necessary media management information during spin up. If not enabled, the media management information will recovered on the first media access command.

Perform the following procedure to enable or disable the MM SpinUp option.

- 1) Enter the Configuration mode by pressing both the LOAD/MENU and TEST/SELECT switches simultaneously.
- 2) Press the MENU switch until "Set Config" is displayed.
- 3) Press the SELECT switch to enter the Set Configuration menu.
- 4) Press the MENU switch until "MM SpinUp:" is displayed.
- 5) Press the SELECT switch to scroll through the states for the load switch (on, off). When the desired state is displayed, press MENU to enter the state and move to the next option in the Set Configuration menu.
- 6) Simultaneously press the LOAD/MENU and TEST/SELECT switches to exit the Configuration mode. Simultaneously press the LOAD/MENU and TEST/SELECT Switches again to move up to the Main menu.

VIEWING DIAGNOSTIC RESULTS OR PERFORMING DIAGNOSTIC OPERATIONS ("DIAGNOSTICS")

To enter the diagnostic submenu, press the TEST/SELECT switch while "Diagnostics" is displayed in the Main menu. The drive will enter the Diagnostics menu which includes the following options:

"Park Drive" Press the SELECT switch to park the baseplates for drive shipment. If the "Park Failed, Close Manually" message appears, refer to the [Manual Release](#) section of this manual. Press the MENU switch to select the next option in the Diagnostics menu.

"Test Sensors" Press the SELECT switch to enter sensor display mode. In sensor display mode the DOC panel will display the status of the sensors within the drive. For details, see the LF 6600 Hardware Maintenance Manual (P/N 97653979). Press the MENU switch to select the next option in the Diagnostics menu.

"Clear NvRAM"

CAUTION



Since the initialization variables cannot be recovered once they are cleared, this operation should only be performed by a trained Customer Engineer (CE).

Press the SELECT switch; the message "Drive will reset and NvRAM will be cleared! To Continue Press Select" will appear. Press the MENU switch if you do not want to clear the nonvolatile memory (NvRAM) initialization variables; press the SELECT switch to clear the NvRAM initialization variables in the drive. Press the MENU switch to select the next option in the Diagnostics menu.

"Cal Shuttle" Press the SELECT switch to enter the Cal Shuttle option. This option allows alignment of the load pin to the center of the cartridge track. If the shuttle requires calibration, press SELECT to continue the calibration procedure. Follow the instruction displayed at the DOC. During the calibration procedure, the message "Align Slot "1 and "Close Door" will alternate at the DOC. When the cal procedure has been completed, press LOAD/MEDIA switch to return to the MAIN menu.

"View CDEs" Press the SELECT switch to view the controller detected error (CDE). The DOC will display the error code. When no error has occurred, the "No CDE Error" message is displayed. The error code is cleared upon exiting the Diagnostics menu. The error code should be logged by the operator for aiding the CE in diagnosing the drive problem. Press the MENU switch to select the next option in the Diagnostics menu.

"Sys Log:"

Press the SELECT switch to enable or disable system event logging. The log can be used by a trained CE to help in problem isolation or for performance monitoring. Drive performance will be slowed and may not meet specification if logging is enabled. The default is "Sys Log Off". Press the MENU switch to select the next option in the Diagnostics Menu.

"Test Thru:"

Press the SELECT switch to set the level of diagnostics tests which will be performed during selftest (refer to the next table). Selftest is invoked by pressing the TEST switch on the DOC panel. Tests always start at test 0 and continue through the test number selected by the "Test Thru:" option. For example, if test 5 is selected ("Test Thru:5"), selftest diagnostics will include tests 0 through 5. This selftest series will be performed each time the TEST switch is pressed.

Press the MENU switch to select the next option in the Diagnostics Menu.

Diagnostics Selftests

TEST #	DESCRIPTION OF TEST
0	Power-on self-test. This test cannot be disabled; it runs automatically when the drive is powered on.
1	PCA Self-tests, DPR Communication
2	Read/Write Data Path
3	OMA
4	Cartridge Guide and Shuttle Sensors
5	Baseplate and Spindle Motor Operation
6	Servo Control Systems
7	Read Performance
8	Write Performance, Write Power Calibration
9	Reserved

"View RTPM"

Press the SELECT switch to view the RTPM (Real Time Performance Monitor) status. If no RTPM error has occurred, the DOC will display "No RTPM Err". If an RTPM error has occurred, the DOC will display the media serial number and drive channel combination which caused the RTPM error. The media serial number will be displayed for 5 sec (S/N: #####) and then the drive channel will be displayed for 4 sec (Channel: A, B, or A+B). The display will then return to the View RTPM option.

"Clear RTPM"

CAUTION



RTPM errors indicate the drive or media require maintenance, and place the drive in a read only mode. Corrective action may be as simple as cleaning the media that caused the error, or may require the attention of a trained Customer Engineer (CE) to repair the drive. Clearing this error without resolving the cause may reduce the total media capacity because of abnormally high relocations during write operations.

Press the SELECT switch; if an RTPM error has not occurred, the message "No RTPM Err" will briefly appear and the display will return to "Clear RTPM". If an RTPM has occurred, a confirmation message will be displayed. Press the SELECT switch to clear the RTPM error and enable writing. Press the MENU switch to select the next option in the Diagnostic (Park Drive) menu without clearing the RTPM error. The drive will not perform write operations with an RTPM error.

"Init DPC"

Press SELECT switch to Initialize DPC. This option will clear all the serial E-Prom values and reset the drive.

A structure diagram for the Diagnostics menu is shown in the next figure.

To move up a level in the configuration menu hierarchy to the Main menu, press the LOAD/MENU and TEST/SELECT switches simultaneously.

To exit the Configuration mode, press the LOAD/MENU and TEST/SELECT switches simultaneously from the Main menu. The display will show the message which appeared prior to the drive entering the Configuration mode.

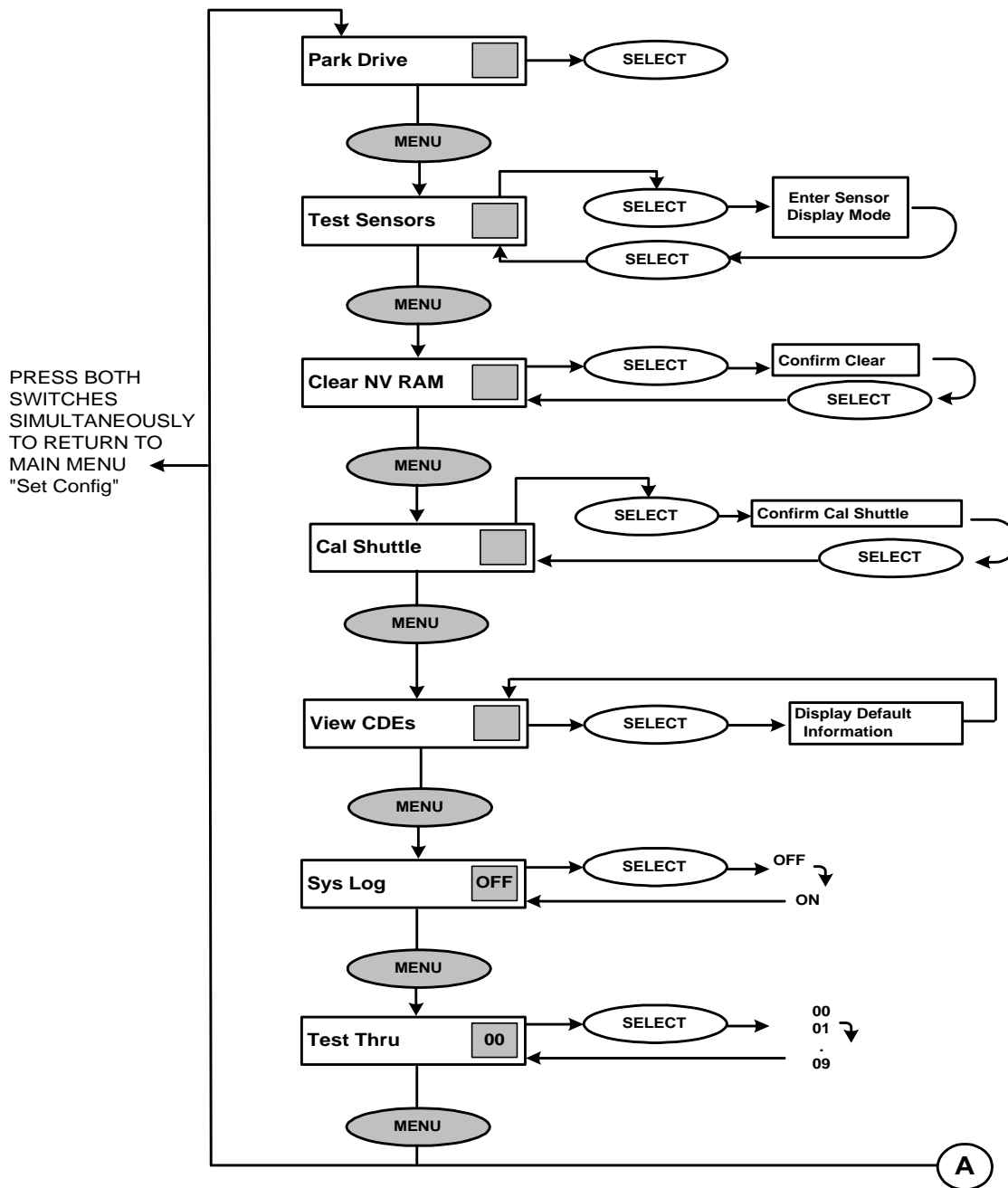

Diagnostics Menu (Part 1)

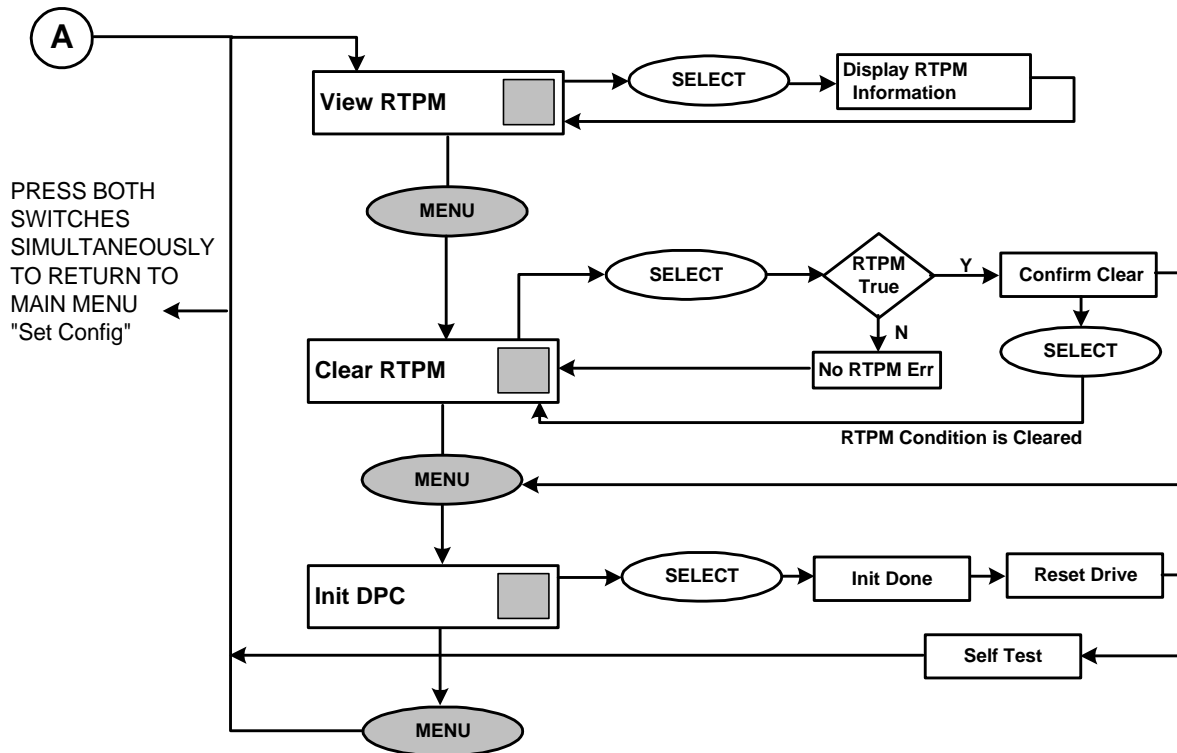

Diagnostic Menu (Part 2)

SET THE INTERNAL DRIVE SERIAL NUMBER ("SET SERIAL #")

To enter the serial number submenu, press the TEST/SELECT switch while "Set Serial #" is displayed in the Main menu. The drive will enter the menu allowing the operator to view and change the internal drive serial number.

NOTE

The serial number set in the drive must correspond to the last 5 digits of the drive's actual serial number for accurate internal event logging to occur. The drive's actual serial number is located on the back of the drive enclosure.

To change the drive's 5-digit serial number, follow these steps:

- 1) Enter the Configuration mode by simultaneously pressing the LOAD/MENU and TEST/SELECT switches.
- 2) Press the MENU switch until "Set Serial #" is displayed.
- 3) Press the SELECT switch to enter the serial number mode. The serial number will be displayed.

- 4) If the serial number does not require revision, simultaneously press the LOAD/MENU and TEST/SELECT switches to move up to the Main menu. Simultaneously press the LOAD/MENU and TEST/SELECT switches again to exit Configuration mode.

If the serial number requires revision, press the MENU switch until the digit position to be changed is blinking. Then press the SELECT switch until the desired digit value is displayed. Continue to select digit positions and values until the correct serial number is displayed.

- 5) Simultaneously press the LOAD/MENU and TEST/SELECT switches to move up to the Main menu. Simultaneously press the LOAD/MENU and TEST/SELECT switches again to exit Configuration mode.

A structure diagram for the Set Serial # menu is shown in the next figure.

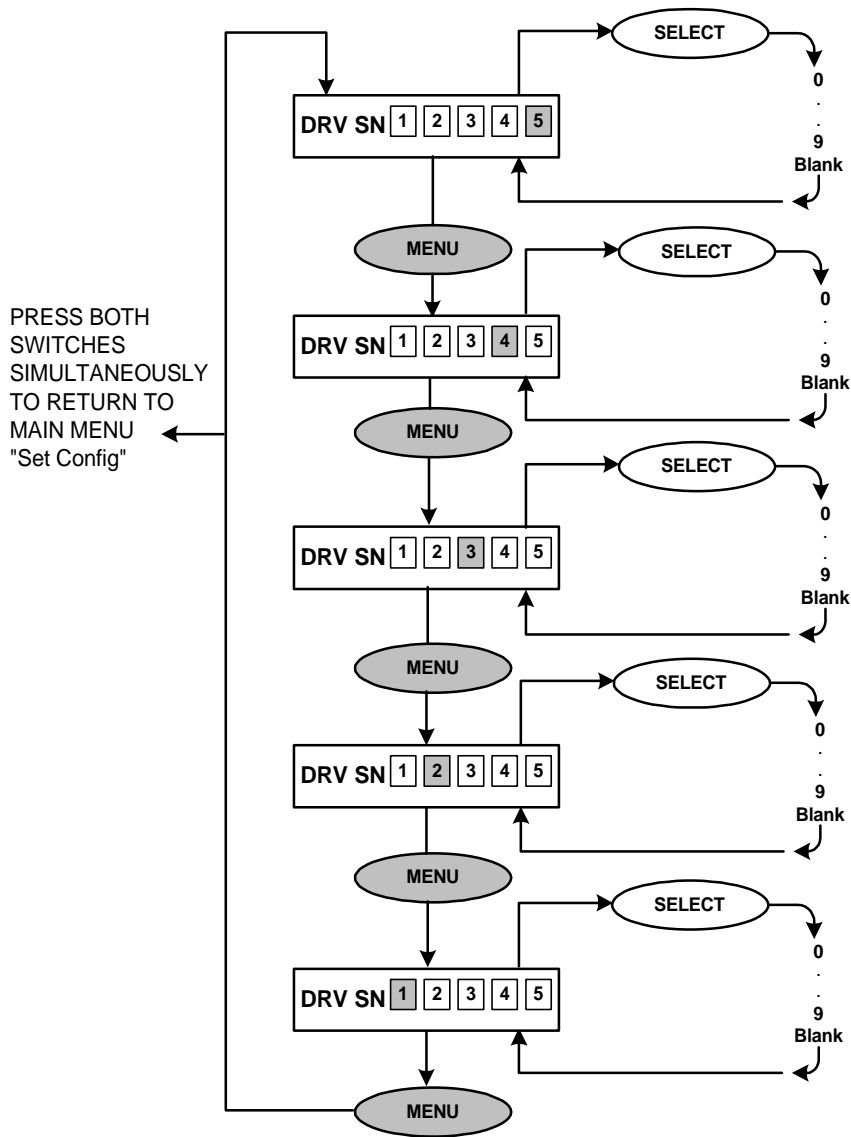

N = Digit to be Set is Flashing

Set Serial # Menu

TEST MODE

Each LF 6600 automatically enters the Test mode each time it is powered on. Power-on selftest diagnostics are run to verify the operational readiness of the drive.

After the LF 6600 successfully passes the power-on selftests, the drive enters the Operating mode. When the LF 6600 is in the Operating mode, the operator may manually enter the Test mode and invoke the system function diagnostics.

The level of selftest diagnostic coverage is configurable via the "Test Thru:" option in the Diagnostics menu. Lower level tests (numbers 0 through 6) verify basic drive hardware operation.

When errors are detected, the appropriate diagnostic message will be displayed on the DOC. Diagnostic messages are presented to the operator in the form of failed test codes and Field Replaceable Unit (FRU) mnemonics that can be relayed to a CE for repairing the malfunction.

If no problems are detected by the system function diagnostics, the display will show "Diagnostics Complete. Press TEST to restart drive...".

Pressing TEST resets "Test Thru:" value to 00 and initiates selftest option. At the successful completion of this selftest, the LF 6600 is returned to the operating mode, ready for normal operation.

MEDIA CARTRIDGE HANDLING

The LM 6000 media is used in all LD 6100/LF 6600/LF 6602 drives. The LM 6000 media cartridge, illustrated in the next figure, is shipped ready for immediate use and does not require preformatting.

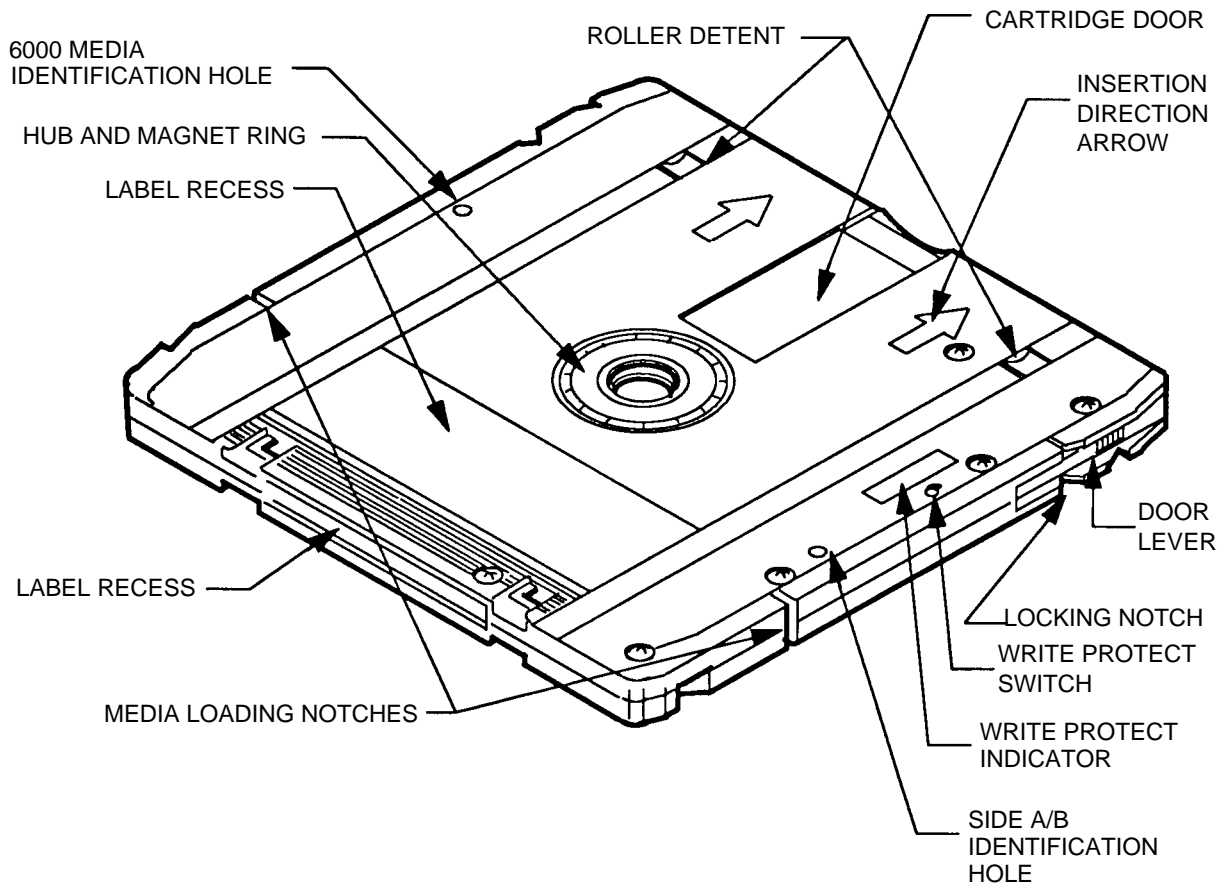

The LM 6000 Media Cartridge

EP006708

The LM 6000 media cartridge has visible arrows to indicate the direction of insertion into the shuttle slots. Take care to insert the media with the correct orientation. The media cartridge has a write protect switch which write protects both sides of the media when the switch is in the active position.

Observe the following precautions to ensure data integrity when handling or storing a media cartridge:

- 1) Do not drop the media cartridge onto hard surfaces.
- 2) Do not physically abuse the cartridge exterior or access mechanisms.
- 3) Do not store the media cartridge in the drive.
- 4) Remove cartridges from the drive when the drive is going to be moved.
- 5) Apply labels only in designated areas. Refer to the Affixing Label section for instructions on label placement.
- 6) Avoid exposing the media cartridge to direct sunlight and condensation.

CAUTION



Careful attention to the environmental constraints specified in the LM 6000 Media Specification (P/N 97647044) is strongly recommended to prevent damage to the media.

- 7) Do not expose the media cartridge to temperature extremes.
- 8) Stabilize the media cartridge to the specified operating temperature range 1 hr before use.
- 9) Do not open the media access shutter.
- 10) Do not touch the disk surface through the media access shutter.
- 11) Do not remove the disk from the cartridge.
- 12) Use, handle and store the media cartridge in clean office conditions.
- 13) Do not smoke while handling the media. Smoke is a prime source of disk contamination. All smoking materials should be kept away from areas where the media are in use or storage.
- 14) Keep external surfaces of the cartridge clean. Dust the cartridge periodically with a soft, dry, lint-free cloth.

For more information concerning media care and handling, refer to the LM 6000 Media Specification (P/N 97647044).

SETTING THE WRITE PROTECTION SWITCH

To manually write protect a cartridge, set the write protect switch on the data cartridge as indicated in the next figure.

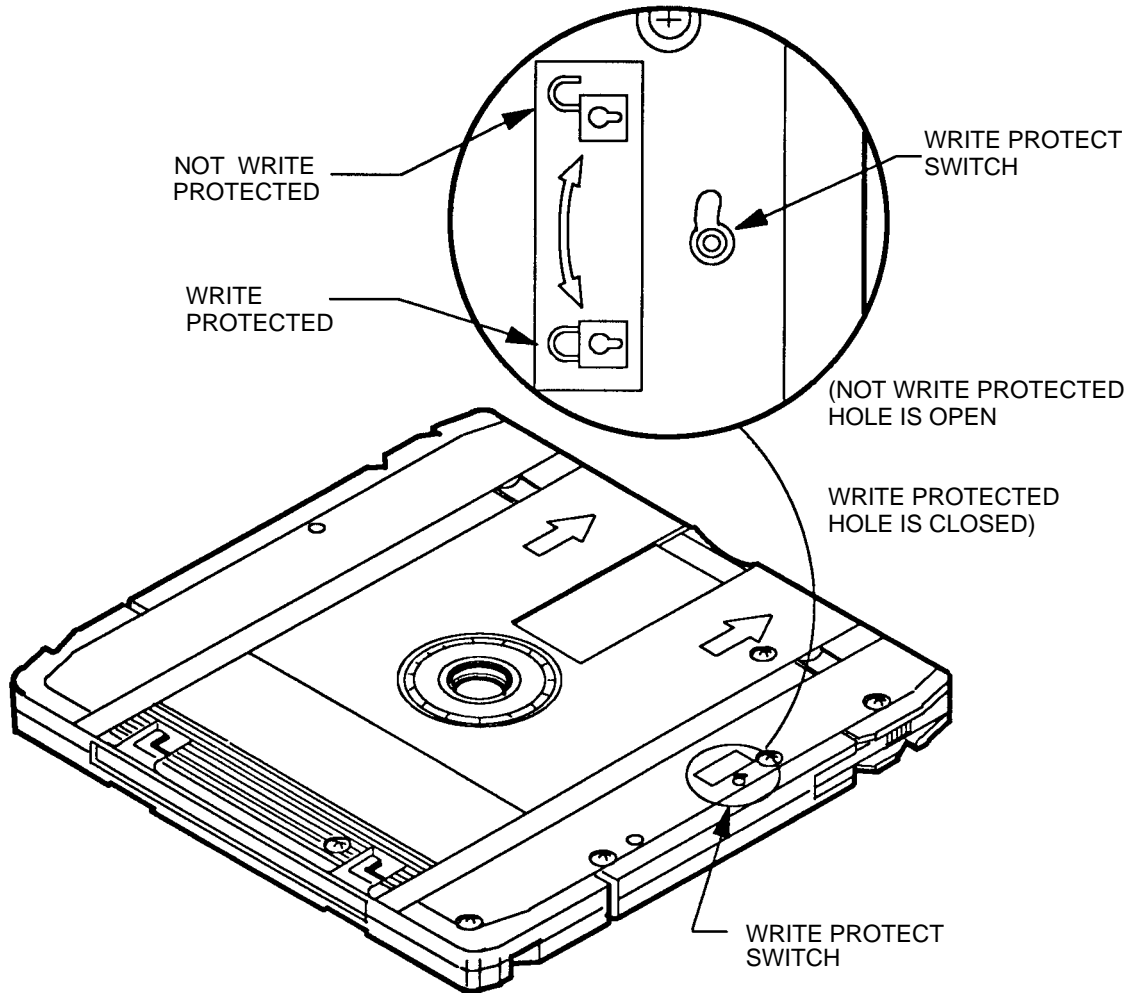

Manually Write Protecting the Media Cartridge

EP004350

AFFIXING LABELS

Title and content labels are supplied with each LM 6000 media cartridge and should be affixed before the cartridge is inserted into the LF 6600. Before affixing the labels in the recessed areas (see figure below), ensure that the surface of the cartridge is clean and dry.

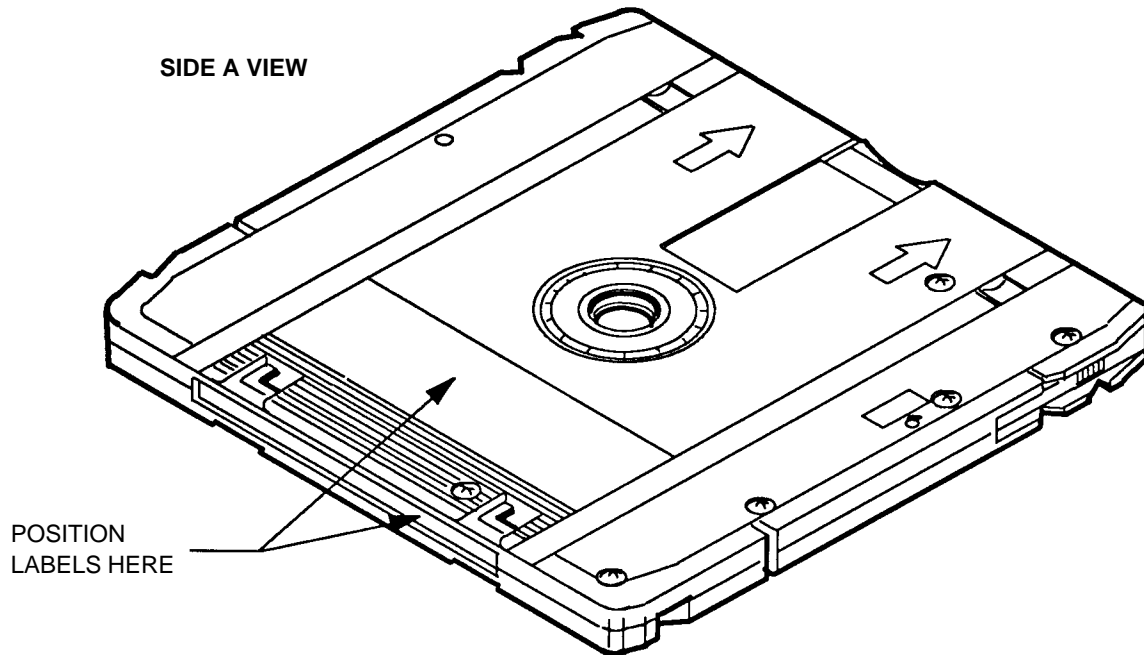

Label Placement

EP004111

MEDIA INSERTION AND REMOVAL

MEDIA ACCESS DOOR

Individual media cartridges are inserted and removed through the front panel media access door. When fully closed, the door is held by magnetic contacts. A safety switch prevents operation of the shuttle if the door is open. When the door is opened and closed, the drive tests the six slots to determine which slots have media cartridges present.

The door is automatically locked by a electrical safety lock when the drive begins operation. An independent manual key lock, located in the bezel assembly, provides an additional locking method for preventing unauthorized media access.

Operator access to the media requires the shuttle to be in the home position. The home shuttle position squarely aligns all six cartridge slots with the media access door as illustrated in the next figure.

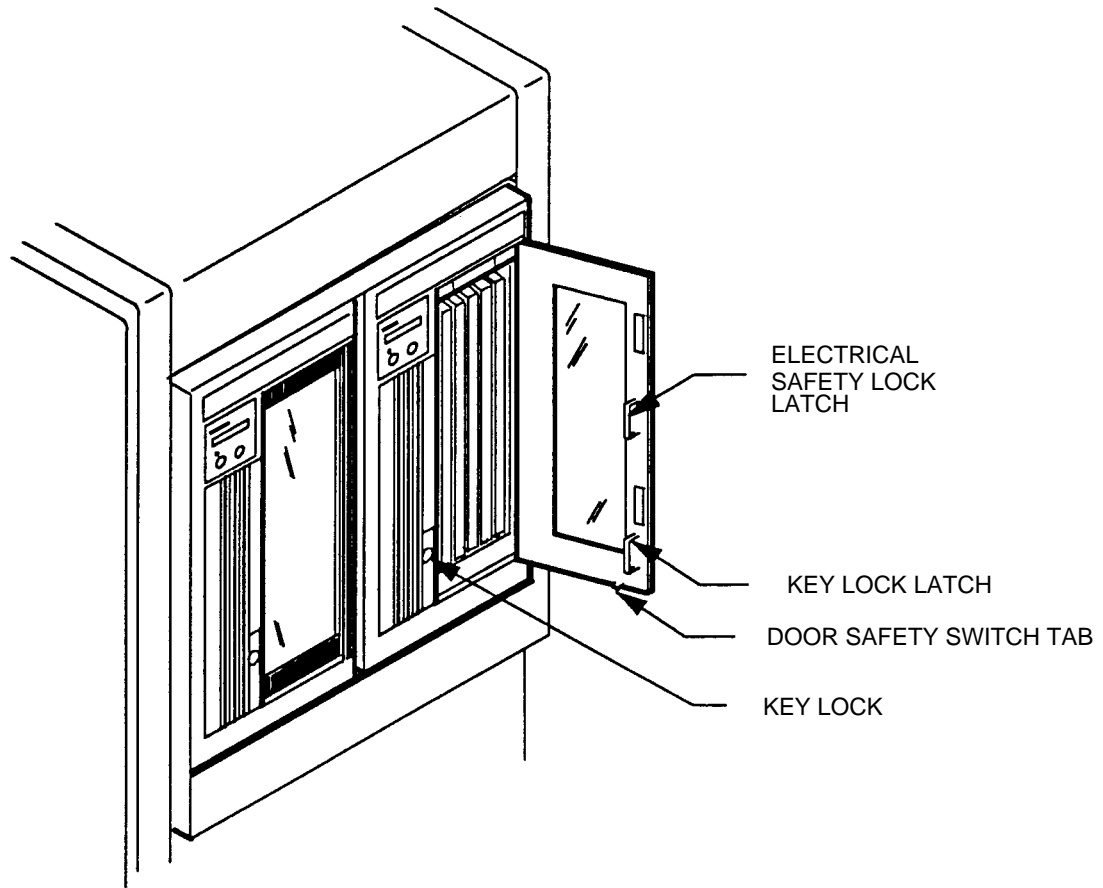

LF 6600 Media Access

EP006026

Returning the shuttle to home can be accomplished by host command or by pressing LOAD/MENU at the DOC. If access is authorized, the drive will unload the media cartridge into the shuttle, move the shuttle to the home position, and unlock the electrical safety door lock. If access is denied by command from the host, pressing LOAD/MENU will have no effect and the DOC will briefly display the "Denied" message.

CARTRIDGE INSERTION

LM 6000 media cartridges are inserted directly into the LF 6600 shuttle via the media access door described in the Media Access Door section. Ensure that the arrows on the cartridge point toward the shuttle and insert the cartridge into the slot until it is fully seated and its back edge is flush with the edge of the shuttle.

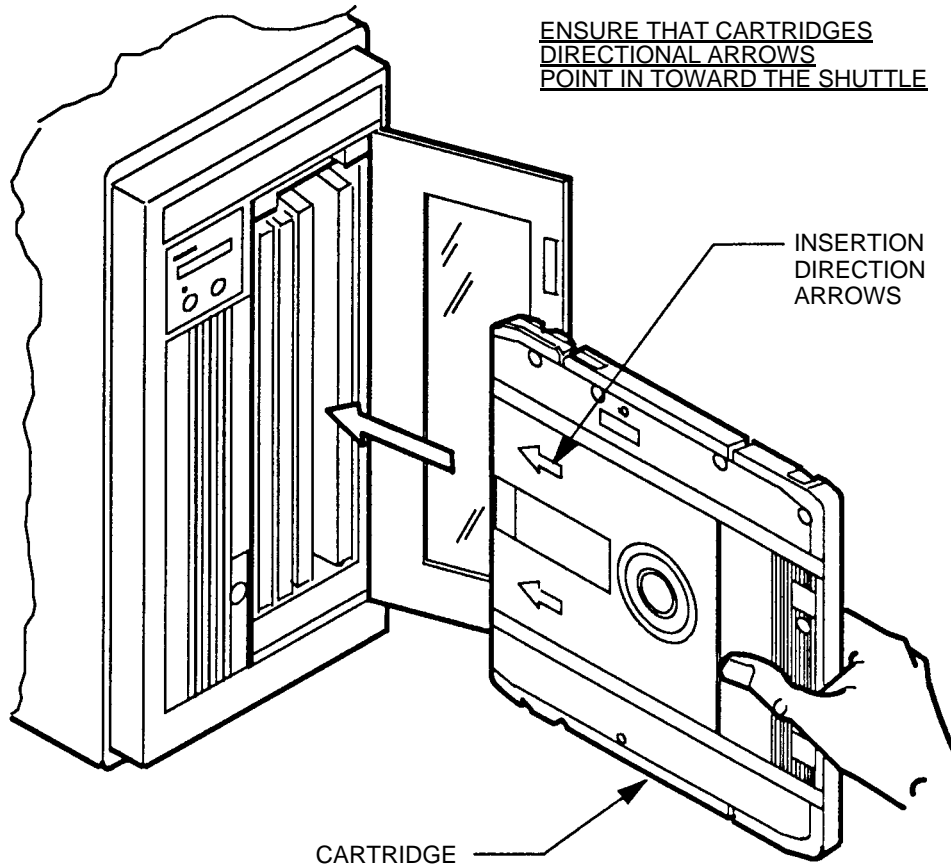

Data Cartridge Insertion

EP006091

CARTRIDGE REMOVAL

LM 6000 media cartridges may be removed from the media access door. To aid in removing the closely spaced cartridges, the top rear edge of the shuttle is cut away and a notch is provided on the exposed edge of each cartridge. Pulling on the cartridge notch with one finger as shown in the next figure, will back the cartridge out far enough so that it can be grasped and removed.

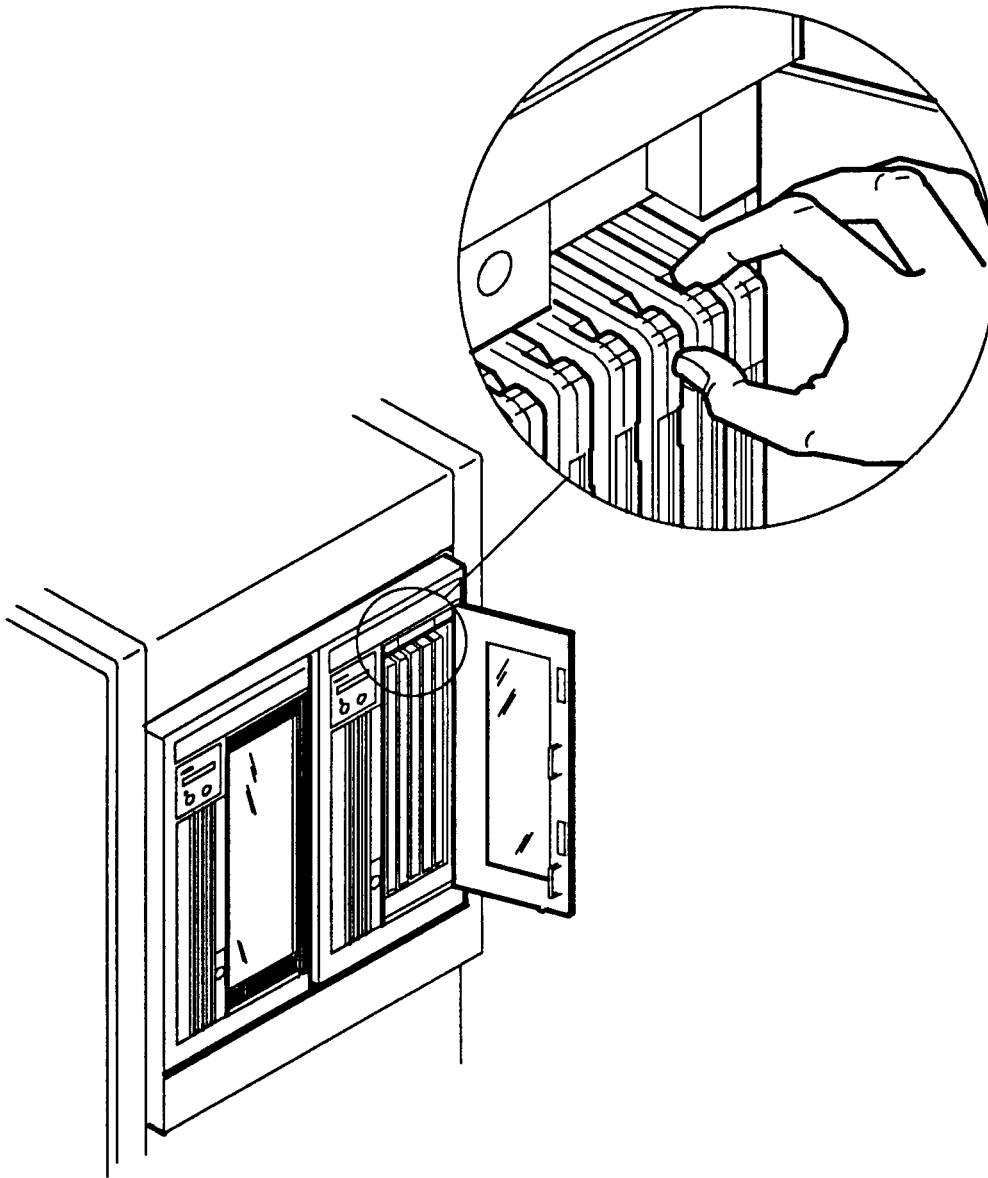

LM 6000 Cartridge Removal

MANUAL CARTRIDGE RELEASE MECHANISM

If power fails or if the drive fails with a media cartridge inserted, the media cartridge can be manually removed by opening the drive baseplates, removing the bezel and then retracting the cartridge.

OPENING THE BASEPLATES

With the manual release tool, perform the following procedure:

- 1) Move the AC power switch to the OFF (O) position and disconnect the AC power cable from the wall outlet.
- 2) At the rear panel, insert the manual release tool into the upper access hole and engage the recessed D-shaped shaft. Turn the tool handle counterclockwise as far as it will turn to open the upper baseplate.
- 3) Repeat step 2) at the lower access hole to open the lower baseplate.

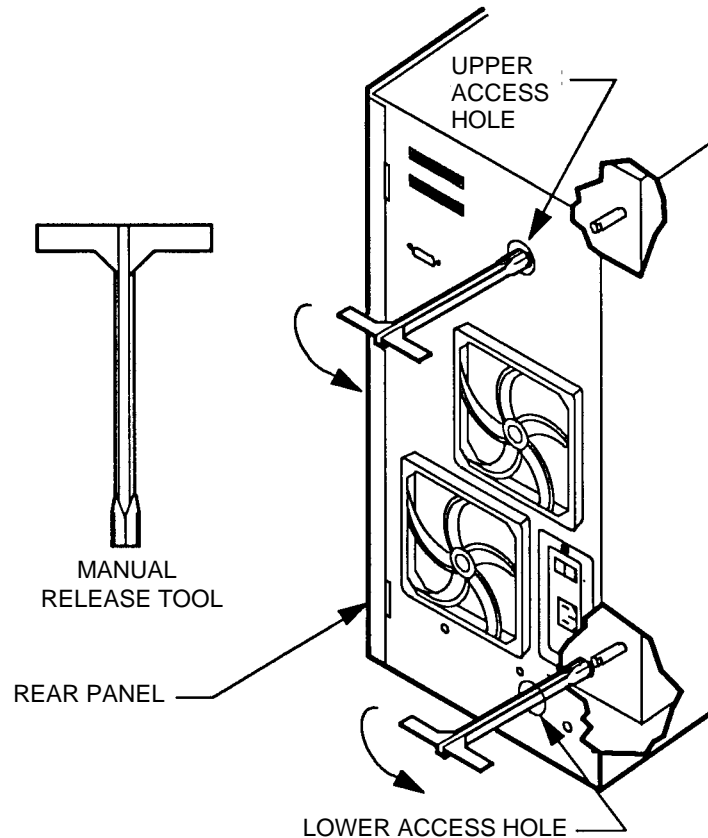

Manually Opening the LF 6600 Baseplates

EP006046

REMOVING THE BEZEL

NOTE

A T15 screwdriver is required for removing the bezel assembly.

- 1) Release the electrical safety door lock by inserting the flat handle end of the manual release tool through the slot in the bezel and move the locking lever to the left out of the door lock tab as shown below.

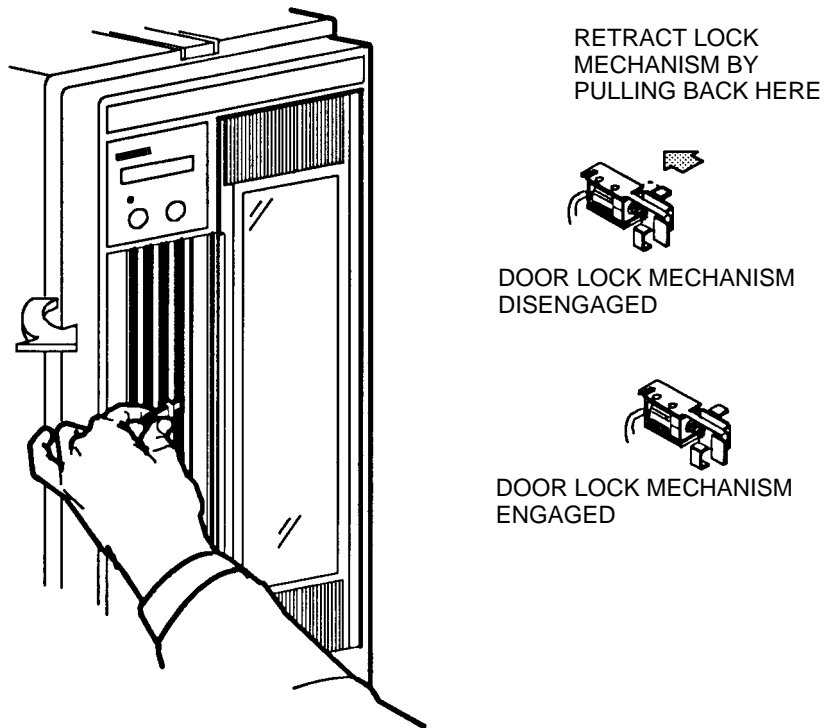

Manually Overriding the Door Lock

EP006037

- 2) Open the media access door and remove the M4 x 20 mounting screw. Unplug the door safety switch cables at the chassis and remove the bezel assembly by pulling it up and away from the lower mounting tabs on the chassis as shown in the figure below.

CAUTION



Ensure that you do not damage the door safety switch cables when you are removing the bezel.

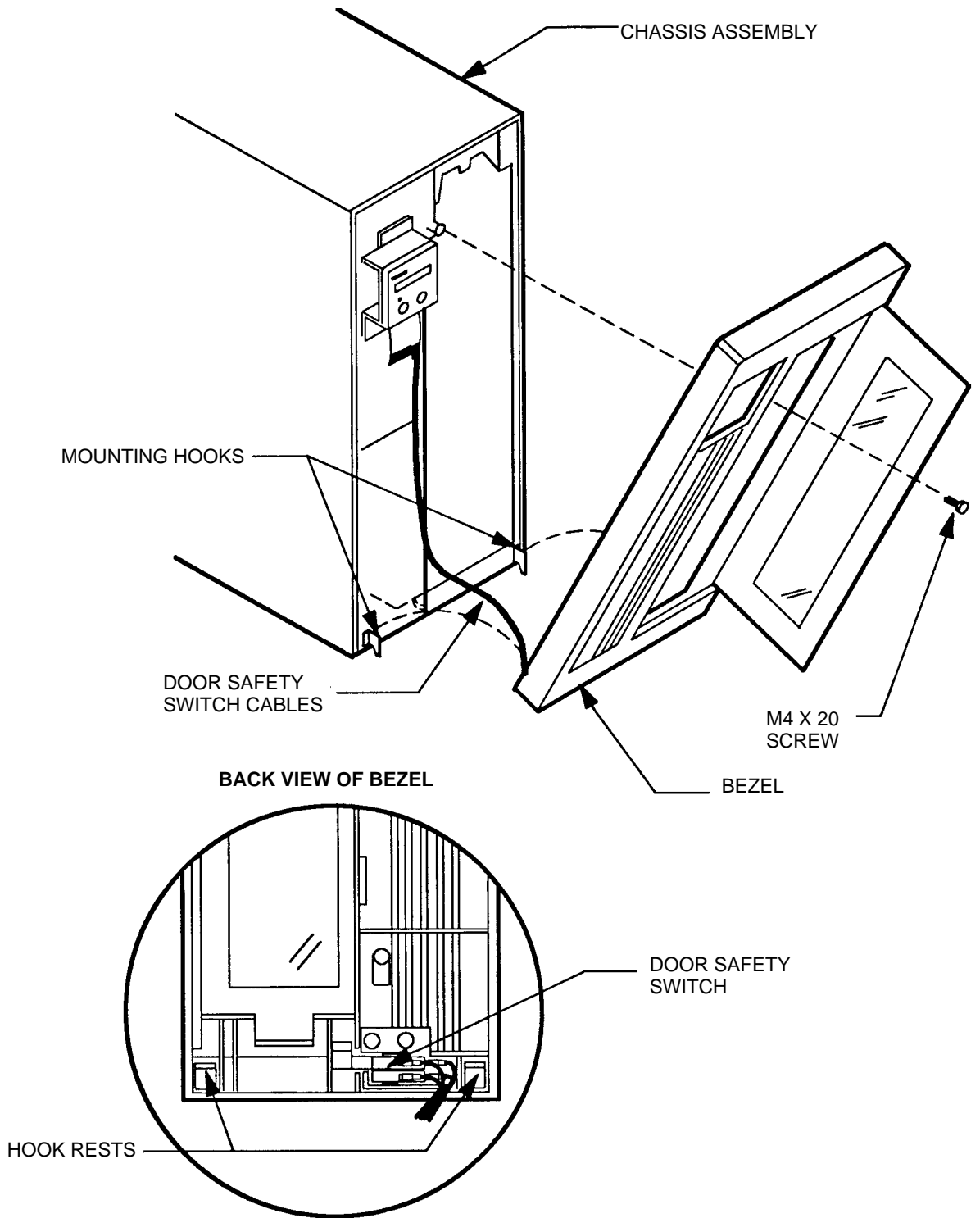

Bezel Removal

EP006044

RETRACTING THE CARTRIDGE

- 1) Insert the manual release tool onto the D-shaped shaft at the front of the drive as shown below to operate the cartridge insertion mechanism. Turn the tool clockwise as far as it will turn, pulling the cartridge back into the shuttle.

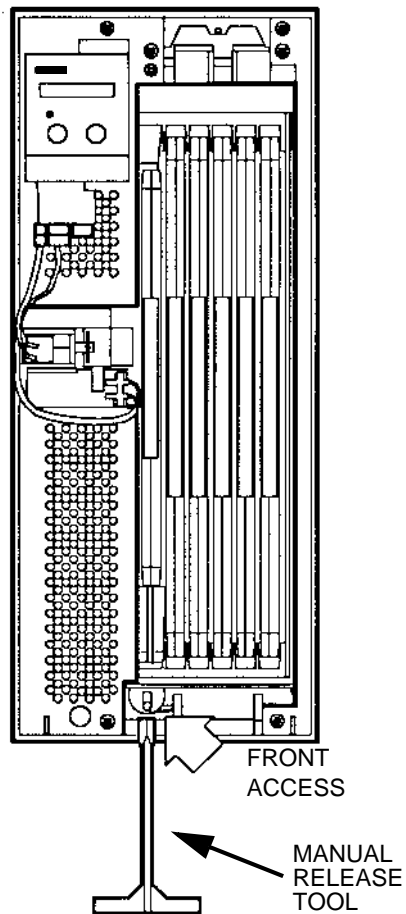

LF 6600 Manual Cartridge Retraction

EP006040A

2) Manually move the shuttle to the home position as shown below.

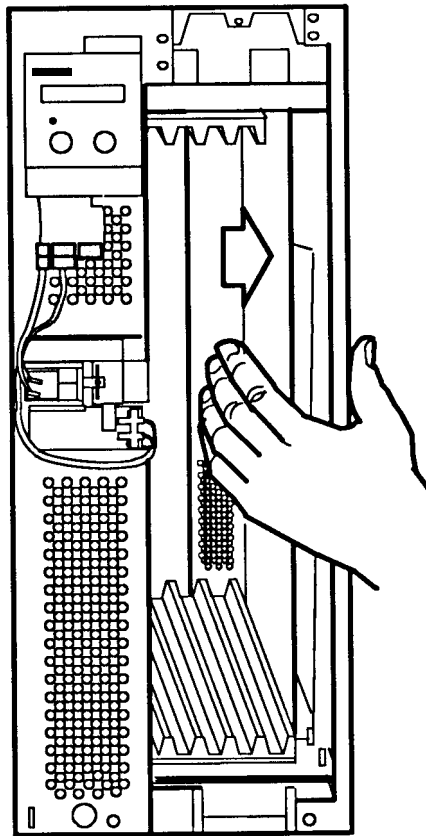

Manually Moving the Shuttle Assembly to the Home Position

EP006039

3) Remove the cartridge from the shuttle slot.

MEDIA LOADING

Individual media cartridges can be selected for loading by host command or by the autoloader configuration option. The host can select and load a media cartridge from any shuttle slot by issuing an appropriate SCSI bus command.

Selection by the autoloader configuration option occurs at initial power up and when the LOAD/MENU switch on the DOC is pressed while the LF 6600 is in Operating mode. Depending on the setting of the autoloader option, the LF 6600 automatically inserts and loads one specified media cartridge or the most recently used (MRU) cartridge or moves the shuttle to the home position.

If the selected cartridge is not present, the DOC displays "# Empty", where # represents cartridges 1-6.

For more information on viewing and setting drive configuration options, refer to the Configuration Mode section of this manual.

OPERATOR MAINTENANCE

ACCESSING DRIVES

During operator maintenance, if you need to extend and access a drive through the front of the LF 6602, perform this procedure:

- 1) Disconnect a drive from the shipping bracket at the rear of the LF 6602 by unfastening the four M4 screws (see figure below).

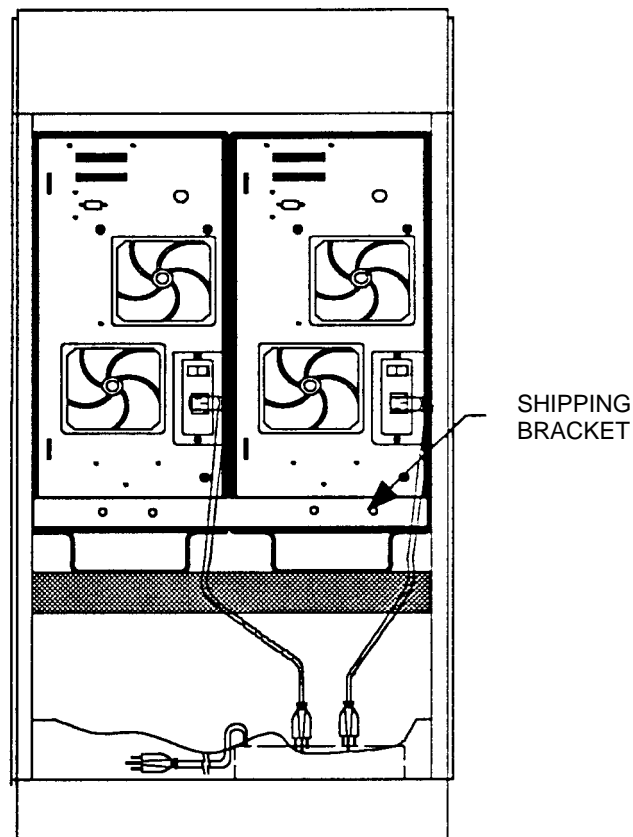

Disconnecting a Drive from the Shipping Bracket

EP006031A

- 2) Pull off the cabinet's trim panel (see next figure).
- 3) Press down on the front release levers of one drive's rack mount slide and pull the drive out, away from the cabinet.

An interlock is incorporated into the design of the LF 6602's front panel to allow the extension of only one drive at a time. If the interlock is defeated and if both drives are extended simultaneously on their rack mount slides, the cabinet will become unbalanced and will topple over.

WARNING



Do not defeat the LF 6602's interlock and do not extend both drives simultaneously.

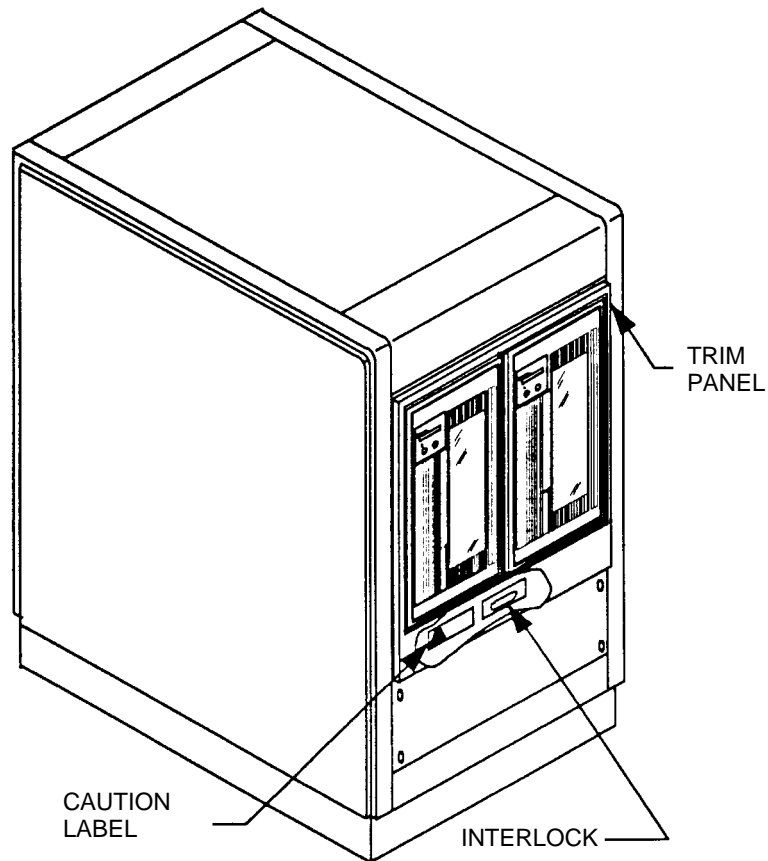

LF 6602 Cabinet Configuration Showing Interlock Location

EP006083

- 4) After you have finished, return the extended drive to its original position in the cabinet; remount the shipping bracket on the rear of the cabinet and secure the bracket by re-installing the four screws.
- 5) Re-install the cabinet's trim panel.

INSPECTING AND CLEANING FAN AND BLOWER FILTERS

Two filters located on the drive's rear panel remove contaminants from air pulled into the drive (see figure below).

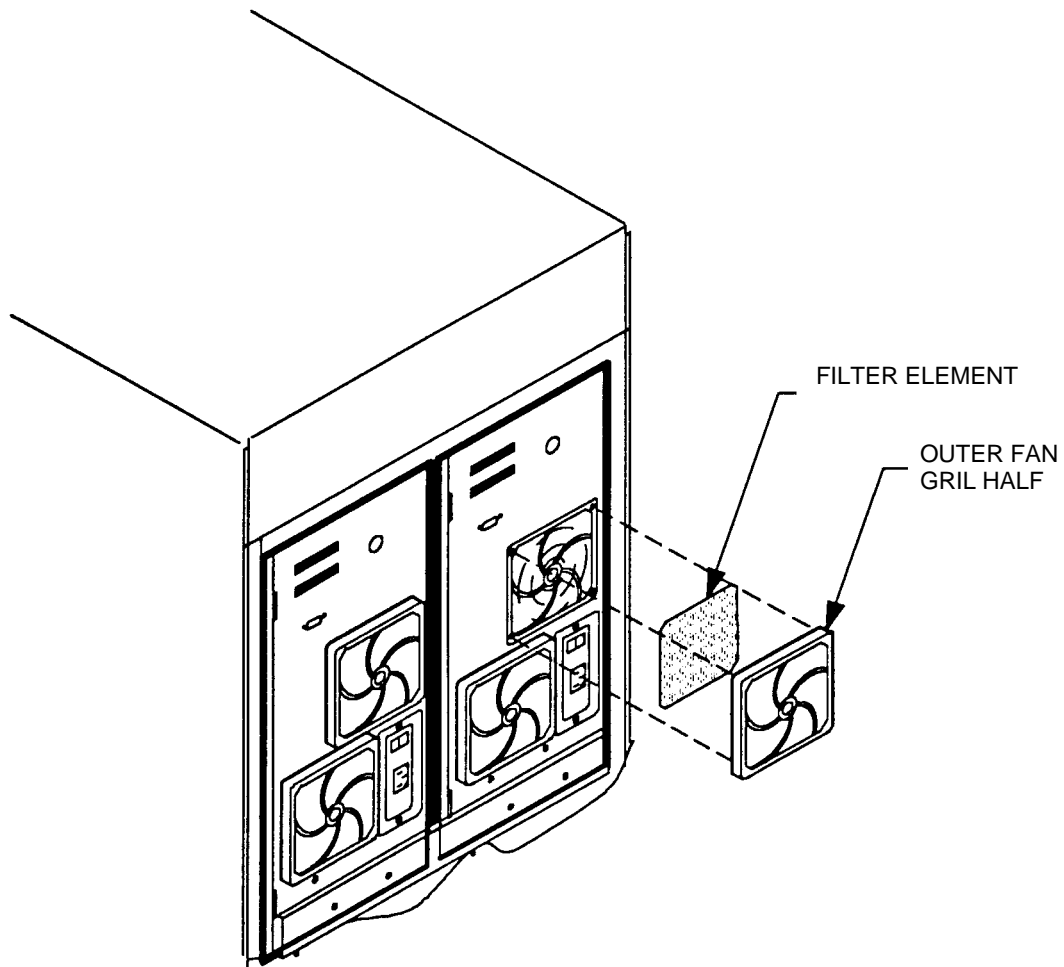

Removing Filter Element from Fan

EP006088

Inspect the Filters at the rear of the drive on a 1 - 6 month schedule and clean, if necessary, to ensure that cooling air flow is not restricted. If the drive is exposed to excessive amounts of dust, decrease the time between inspection intervals.

Remove dust on the drive's exterior with a dry, lint-free cloth. Dust can migrate to the media cartridge and cause performance degradation.

CAUTION



Failure to maintain a clean Filter Element can reduce air flow through the drive. This will create high temperatures in each LF 6600 which may shorten the life of the drive.

Perform the following procedure to clean the fan filter elements:

- 1) Unlock and open the cabinet door.
- 2) Set each drive's AC power switch to the OFF (O) position and verify that the fan and blower have stopped running.
- 3) Remove each Outer Grill Half by grasping its sides and pulling it away from the chassis.
- 4) Remove each Filter Element by pulling it away from the inside of the Grill.
- 5) Wash each Filter Element in warm soapy water.
- 6) Rinse each Element thoroughly and let it air dry.
- 7) Re-install each Filter Element in the Outer Grill Half.
- 8) Replace the Outer Grill Half by snapping it onto the Inner Grill half.

REPLACING FUSES

As stated in the AC Power Requirement section of this manual, two fuses and two spare fuses are integrated into the power receptacle on the rear panel of each LF 6600 (refer the next figure). If the drive will not power up, one or both of the fuses may have blown.

To replace a blown fuse with a spare fuse for each drive:

- 1) Set the drive's AC power switch to the OFF (O) position and remove the AC power cord.
- 2) Insert a small, flat-blade screwdriver between the fuse holder and the receptacle housing, as shown in the next figure.

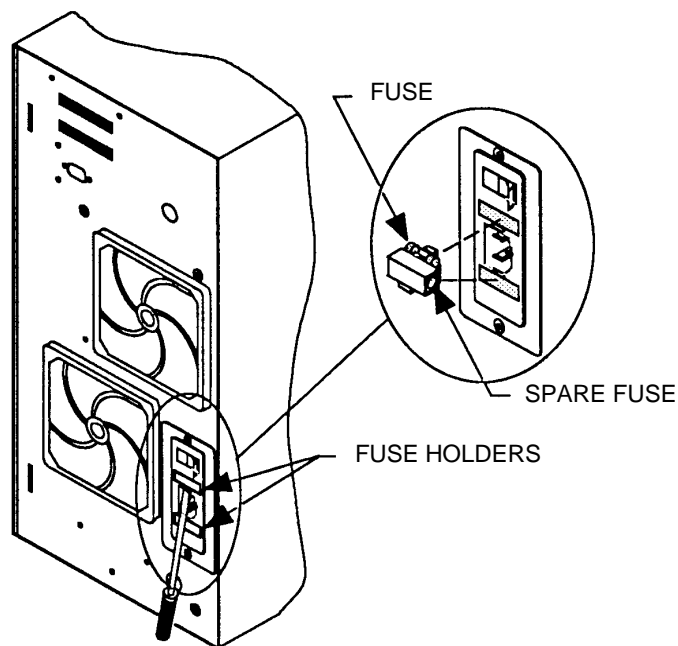

Removing Fuse from AC Power Receptacle (Rear View of Unit)

EP006079

- 3) Gently pry the fuse holder open. Slide the fuse holder out of the receptacle and visually inspect the active fuse to determine if it is blown. If the active fuse is blown, proceed to step 4); otherwise, proceed to 5).
- 4) Remove the active fuse and discard it. Remove the spare fuse from its storage location and insert the fuse between the fuse housing and the retaining clip.
- 5) Re-install the fuse holder into the receptacle, sliding the holder into the receptacle until the holder is aligned flush with the receptacle housing.
- 6) Refer to the Power -On Procedure section.
- 7) If power is not restored, check the other fuse.

WARNING



If a spare fuse blows immediately after you have replaced the original fuse, contact your next level of support.

Do not replace the spare fuse.

This may be a symptom of a more serious problem, either with the drive's power supply or with the system power.

MEDIA CLEANING

Media disk surfaces should be inspected periodically and cleaned on an as-needed basis.

MEDIA CLEANING USING CLEANING KIT P/N 97662550

The Cleaning Kit P/N 97662550 provides a semi-automated cleaning method for cleaning the Plasmon LM 4000 and LM 6000 12 inch optical media. Follow the instructions given in the enclosed Cleaning Instructions.

The Kit contains the following items:

- One 12 inch media cleaning fixture
- One container of cleaning liquid
- One package of 500 cleaning tissues
- One pair of latex gloves
- Cleaning Instructions

ACCESSORIES

The following accessories are available from Plasmon LMS.

The cables listed in the table below can be purchased to connect product and host. All Plasmon SCSI cables are shielded and can be used for both Differential and Single Ended applications.

Optional SCSI Cables

PLASMON Part Number	Length	Connector A	Connector B
77050622	1 M (3.3 ft)	50 pin high-density Alt 1-A cable-Male, Rt angle	50 pin high-density Alt 1-A cable-Male, Rt angle
97654406	1 M (3.3 ft)	50 pin high-density Alt 1-A cable-Male	68 pin high-density B cable-Male
97654408	1 M (3.3 ft)	50 pin low-density Alt 2-A cable-Male	68 pin high-density B cable-Male
97653532	1 M (3.3 ft)	68 pin high-density B cable-Male	68 pin high-density B cable-Male
97654499	1 M (3.3 ft)	68 pin high-density B cable-Male	68 pin high-density B cable-Male
97660914	12 M (39.6 ft)	68 pin high-density B cable-Male	68 pin high-density B cable-Male
97655289	2 M (6.6 ft)	50 pin high-density Alt 1-A cable-Male, Rt angle	50 pin low-density Alt 2-A cable-Male, Straight
97655292	2 M (6.6 ft)	50 pin high-density Alt 1-A cable-Male, Rt angle	50 pin high-density Alt 1-A cable-Male, Lt angle
97654500	2 M (6.6 ft)	68 pin high-density B cable-Male	68 pin high-density B cable-Male
97655290	4 M (13.2 ft)	50 pin low-density Alt 2-A cable-Male	50 pin high-density Alt 1-A cable-Male, Rt angle
97655291	4 M (13.2 ft)	50 pin high-density Alt 1-A cable-Male, Rt angle	50 pin high-density Alt 1-A cable-Male, Lt angle
97654409	4 M (13.2 ft)	50 pin low-density Alt 2-A cable-Male	68 pin high-density B cable-Male
97660913	4 M (13.2 ft)	68 pin high-density B cable-Male	68 pin high-density B cable-Male
97655288	19.1 cm (7.5 in)	50 pin high-density Alt 1-A cable RT angle-Male	50 pin high-density Alt 1-A cable Lt angle-Male

The table below contains optional SCSI accessories such as terminators and adapters that can be purchased to connect the drive to the host.

Optional SCSI Accessories

PLASMON Part Number	Product Description	Type	Connector A	Connector B
97653447	Interface Adapter 50 to 68 pin	Adapter	50 pin high-density Alt 1-A cable-Male	68 pin high-density B cable Female
97654411	Interface Adapter AS/400 for 6501 Controllers	Adapter	Special long pin 68 pin high-density B cable-Male	68 pin high-density B cable Female
97654412	Interface Adapter RS/600-Wide-68pin	Adapter	68 pin Micro Centronics-Male	68 pin high-density B cable Female
97654413	Trilink Adapter	Adapter	68 pin high-density B cable Male	Two 68 pin high-density B cable connectors Female, Female
97655293	Terminator-Passive	S/E Terminator	50 pin high-density Alt 1-A cable-Male	None
97655294	Terminator	Differential Terminator	50 pin high-density Alt 1-A cable-Male	None
97655295	Terminator-Active	S/E Terminator	50 pin high-density Alt 1-A cable-Male	None
97653428	Terminator	S/E Terminator	68 pin high-density B cable Male	None
97653429	Terminator	Differential Terminator	68 pin high-density B cable Male	None
97655539	Pass Thru Terminator	S/E Terminator	68 pin high-density B cable Male	68 pin high-density B cable Female
97655540	Pass Thru Terminator	Differential Terminator	68 pin high-density B cable Male	68 pin high-density B cable Female

Differential and Single - ended Cable Kits

PLASMON Part Number	Product Description	Includes
SP97660827	Kit, Cable, Differential, US	15165428, 97653429
SP97660828	Kit, Cable, Differential, EUR	97646185, 97653429
SP97660829	Kit, Cable, Differential, UK	97646184, 97653429
SP97660830	Kit, Cable, S/E, US	15165428, 97653428
SP97660831	Kit, Cable, S/E, EUR	97646185, 97653428
SP97660832	Kit, Cable, S/E, UK	97646184, 97653428

The table below contains optional power cable part numbers for each country

Optional Power Cables

PLASMON Part Number	Product Description	Length	Connector A	Connector B
15165428	U.S. Power Cord	2 M (6.6 ft)	U.S. AC Plug Male	In-Line Plug Female
97646184	British Power Cord	2 M (6.6 ft)	United Kingdom Plug	In-Line Plug Female
97646185	European Power Cord	2 M (6.6 ft)	Cont. Europe Plug	In-Line Plug Female
97653763	AS/400 Power Cord	2 M (6.6 ft)	In-Line Plug Male	In-Line Plug Female

The table below list the optional media cleaning accessories

Optional Media Cleaning Accessories

PLASMON Part Number	Product Description	Includes
97662550	12 inch Media Cleaning Kit	One 12 inch media cleaning fixture One container of cleaning liquid One package of 500 cleaning tissues One pair of latex gloves Cleaning Instructions
97662548	Media Cleaning Refills	Replacement container of cleaning liquid Replacement package of cleaning tissues

GERMAN TRANSLATIONS / ÜBERSETZUNGEN INS DEUTSCHE

ABMESSUNGEN UND GEWICHT

Die Bezugsabmessungen für den LF 6602 (wie auch aus Abbildung 4 ersichtlich) betragen wie folgt:

Höhe:	99.9 cm
Breite:	53.6 cm
Tiefe:	81.3 cm

Der LF 6602 wiegt 204 kg.

TEMPERATUR, LUFTFEUCHTIGKEIT UND SEEHÖHE

In Tabelle 1 sind die Temperatur-, Luftfeuchtigkeits- und Meereshöhengrenzwerte für die im LF 6602 installierten LF 6600-Laufwerke aufgeführt.

Tabelle 1. Temperatur-, Luftfeuchtigkeits- und Höhengrenzwerte

BEDINGUNG	BETRIEB	RUHE	LAGERUNG/ TRANSPORT ⁽¹⁾
Temperatur	10 bis 42 C ²	-40 bis 66 C	-40 bis 66 C
Maximale Änderungsrate	11 C/h	20 C/h	20 C/h
Luftfeuchtigkeit (Nicht Kondensierend)	10 bis 90%	5 bis 95%	5 bis 95%
Maximale Änderungsrate	10%/h	10%/h	10%/h
Maximale Feuchtkugeltemperatur ³	28 C	46 C	46 C
Minimaler Taupunkt	2 C	2 C	2 C
Seehöhe ⁴	-300 bis 3000 m -300 bis 2000 m Mit Datenträger		Lagerung: -300 bis 3000 m Transport: -300 bis 12000 m

- 1 Die Lagerungsangaben beziehen sich auf maximal 90 Tage in der Plasmon LMS-Verpackung. Kondensation ist nicht zulässig. Die Transportangaben gelten für maximal 1 Woche in einem werkseitig verschlossenen Behälter.
- 2 Falls nicht anders angegeben ist die maximale Betriebstemperatur für ein freistehendes Laufwerk auf Meereshöhe, 42 C. Die maximale Betriebstemperatur über 300 m Höhe wird bei 2000 m Höhe linear auf 38 C herabgesetzt.
- 3 Weitere Informationen zu Temperatur- und Luftfeuchtigkeitsgrenzwerten im Betriebszustand finden Sie in der Produktspezifikation für den LD 6100/LF 6600/LF 6602 (Bestellnr. 97653977).
- 4 Für Datenträger gilt ein Grenzwert von 2000 m. Umgebungsbedingungen und Grenzwerte für Datenträger finden Sie in der Produktspezifikation für den LM 6000-Datenträger (Bestellnr. 97647044).

2.5 STOSS UND VIBRATION

In Tabelle 2 sind die Stoß- und Vibrationskriterien und -grenzwerte für den LF 6602 angegeben:

Tabelle 2. Stoß- und Vibrationskriterien und -Grenzwerte

BEDINGUNG	BETRIEB	RUHE ¹	LAGERUNG/ TRANSPORT ²
Wobbelvibration (Bidirektional) 1 Oktave/Minute	5 bis 22 Hz 0,01 Zoll Doppelamplitude 22 bis 500 Hz, 0,25 g Peak	5 bis 44 Hz 0,03 Zoll Doppelamplitude 44 bis 500 Hz, 3,0 g Peak	5 bis 44 Hz 0,03 Zoll Doppelamplitude 44 bis 500 Hz, 3,0 g Peak
Stoß ³ (Hostwiederholungen Sind U.u. Erforderlich Und Laufwerksleistung Kann Sich Während Des Tests Verschlechtern)	10 msek. Halb- Sinusimpuls Von 10,0 g Peak ⁴		
Unverpackt (3 Achsen)		5 msek. Halb- Sinusimpuls 20 g Peak	
Verpackt Auf Palette			Verpackt Auf Palette 46 cm Fallversuch - Flach

- 1 Mit entfernten Datenträgern
- 2 In LMS-genehmigter Verpackung
- 3 Die Häufigkeit wiederholter Stoßeinwirkungen ist so weit gering zu halten, daß mechanische bzw. elektrische Störungen zwischen den einzelnen Stößen wieder nachlassen.

WECHSELSTROMBEDARF

Der primäre Netzkabeltyp hängt von der bestellten Konfiguration für den LF 6602 ab. Das primäre Netzkabel versorgt die Steckdosenleiste im Gehäuse des LF 6602 mit Strom.

Jeder LF 6602 ist über ein geerdetes Netzkabel an die Steckdosenleiste angeschlossen. Beim LF 6600 ist der Verbindungsstecker in die Netzsteckdose integriert. Schutz gegen Überlaststrom wird durch zwei Sicherungen gewährleistet, die zusammen mit zwei Reservesicherungen in die Netzsteckdose integriert sind. Das Netzteil jedes Laufwerks erfordert die in Tabelle 3 angegebenen Netzspannungen.

Das Netzteil ist selbstregulierend und erfordert kein mechanisches Schalten der Eingangsspannung oder Netzfrequenz.

Tabelle 3. Wechselstrombedarf

FREQUENZ	WECHSELSPANNUNG	LEISTUNG (TYPISCH)	EINSCHALT-STROMSTOSS ¹	NENNLEISTUNG, MIN
47 bis 66 Hz	86,7 bis 128 V	3,0 A	10.0 A	15 A
47 bis 66 Hz	173,4 bis 268 V	1,5 A	5.0 A	15 A

¹ Weniger als 1 Sek., Kaltstarthinweis

HINWEIS

Nach Ausschalten des Stroms müssen Sie 1 Sekunde warten, bevor der Strom wieder eingeschaltet werden darf.

WECHSELSTROMERDUNG

Um einen sicheren Betrieb zu gewährleisten, muß das Gehäuse des LF 6602 geerdet sein. Das Wechselstromkabel enthält eine Erdleitung, die das Gehäuse des LF 6602 durch die Wechselstromversorgung des Standorts an Sicherheitserde legt. Die Wechselstromversorgung des Standorts wiederum muß diese Erdung an einen Erdanschluß legen. Alle Wechselstromverbindungen am Standort müssen denselben Erdanschluß verwenden.

Ein Erdanschlußteil an der Geräterückseite (vgl. Abschnitt 2.2.) kann ebenfalls dazu verwendet werden, den LF 6600 an einen Erdanschluß zu legen. Dieser Erdanschlußteil ist ein 6 mm M4-Bolzen mit Mutter und Sicherungsscheibe.

KIPPTOLERANZ

Ermöglicht den Kippbetrieb von der waagrechten Stellung.

WÄRME AUSSTRAHLUNG

Das Gehäuse des LF 6602 weist während eines Schreib-/Lesevorgangs eine typische Wärmebelastung von 292 kcal/h (1160 BTU/h) auf. Wenn Datenträgerkassetten mit der Maximalgeschwindigkeit des Laufwerks eingelegt, geladen, aktiviert, deaktiviert, entladen und entfernt werden, beträgt die typische Wärmebelastung des LF 6602 ungefähr 364 kcal/h (1450 BTU/h).

WARNHINWEISE

Der LF 6602 ist als Lasergerät eingestuft und unterliegt den US-amerikanischen Anforderungen bezüglich Lasergeräte. Die in Abbildung 5 dargestellten Warnhinweise sind erforderlich, um den US-Bundesvorschriften nachzukommen. Diese Warnhinweise dürfen nicht von den Laufwerken im Gehäuse des LF 6602 entfernt werden.

AUSPACHEN DER LF 6602

WARNUNG



Um Personenverletzungen zu vermeiden, darf der LF 6602 nicht ohne geeignete Hilfsvorrichtungen angehoben werden.

Beim Auspacken und Transport des LF 6602 ist sicherzustellen, daß die Einheit um nicht mehr als 10 Grad gekippt wird. Der LF 6602 wiegt über 181 kg. Wenn die Einheit um mehr als 10 Grad gekippt wird, kann sie unversehens umfallen und zu Personenverletzungen führen.

WARNUNG



Um Personenverletzungen zu vermeiden, sind zwei Personen erforderlich, um den LF 6602 auf einer Rampe nach unten zu rollen.

Hierbei ist sicherzustellen, daß die Einheit um nicht mehr als 10 Grad gekippt wird. Der LF 6602 wiegt über 181 kg. Wenn die Einheit um mehr als 10 Grad gekippt wird, kann sie unversehens umfallen und zu Personenverletzungen führen.

WIEDERVERPACKEN DES LF 6602

Der LF 6602 sollte nur in seiner Originalverpackung wiederverpackt werden. Vor dem Wiederverpacken sind die Grundplatten jedes Laufwerks zu schließen (weiteres hierüber finden Sie unter Schritt 2 im nachfolgenden Verfahren).

VORSICHT



Die Grundplatten der Laufwerke müssen sich in geschlossener Stellung befinden, bevor der LF 6602 transportiert wird. Nur so kann eine nicht unter den Garantieschutz fallende Beschädigung der Laufwerke vermieden werden.

WARNUNG



Der LF 6602 darf nicht ohne geeignete Hilfsvorrichtungen angehoben werden.

WARNUNG



Um Personenverletzungen zu vermeiden, sind zwei Personen erforderlich, um den LF 6602 auf einer Rampe nach oben zu rollen.

Hierbei ist sicherzustellen, daß die Einheit um nicht mehr als 10 Grad gekippt wird. Der LF 6602 wiegt über 181 kg. Wenn die Einheit um mehr als 10 Grad gekippt wird, kann sie unversehens umfallen und zu Personenverletzungen führen.

INSTALLATIONSANFORDERUNGEN

VORSICHT



Vor dem Einschalten der Laufwerke des LF 6600 müssen die Transportblöcke aus Schaumstoff aus den Wagnvorrichtungen entfernt werden.

Wenn der LF 6600 in ein Gerätegestell oder -Gehäuse eingebaut ist, stellen Sie sicher, daß die interne Temperatur des Gestells oder Gehäuses die in der Produktspezifikation und dem vorliegenden Handbuch angegebenen Betriebsgrenzen nicht überschreiten. Senkrecht gestapelte Einheiten erfordern spezielle Aufmerksamkeit im oberen Bereich, in dem höhere Temperaturen herrschen.

Sie müssen das LF 6600 an eine Stromversorgung anschließen, die eine direkte Erdung hat (Netzwerk-/Erdungsverbinding TT = Terminated Terra). Diese Einheit ist nicht für den Einsatz mit einer schwimmenden Erdung (Netzwerk IT = Interrupted Terra) vorgesehen.

Achten Sie darauf, daß das Laufwerk an eine Stromversorgung mit ausreichender Stromstärke angeschlossen ist.

WARNUNG



Um Brand oder Elektroschock zu vermeiden, darf der LF 6602 weder Regen noch Feuchtigkeit ausgesetzt werden. Wartungsarbeiten dürfen nur von qualifizierten Technikern ausgeführt werden.

Trennen Sie die Einheiten im Falle eines Brandes oder einer anderen Notsituation von der Hauptstromversorgung, indem Sie die Stecker aus den Steckdosen ziehen. Sollte das Herausziehen der Stecker nicht möglich oder praktisch sein, trennen Sie die Hauptstromversorgung.

Die betriebsfremde Benutzung von Bedienelementen oder Reglern oder die Durchführung von Verfahren, die im vorliegenden Handbuch nicht beschrieben sind, kann zu einer gefährlichen Belastung durch Laserstrahlung führen.

Vermeiden Sie es, direkt in den Laserstrahl oder dessen Rückstrahlung auf einer reflektierenden Oberfläche zu blicken. Unsichtbare Laserstrahlung kann freigesetzt werden, wenn die Einheit offen ist und die Sicherheitsverriegelungen außer Kraft gesetzt sind.

ANSCHLUßÜBERPRÜFUNG

Vor dem Einschalten des Systems sind folgende Schritte durchzuführen:

- 1) Überprüfen Sie, ob der Host-Adapter, falls vorhanden, ordnungsgemäß abgeschlossen ist.
- 2) Überprüfen Sie, ob der letzte LF 6602 im Bus, falls ein Bus vorhanden, ordnungsgemäß abgeschlossen ist.

VORSICHT



Vor dem Einschalten der Laufwerke ist sicherzustellen, daß die Transportblöcke aus Schaumstoff aus den Wagnvorrichtungen entfernt wurden.

Anweisungen zum Einschalten des Systems finden Sie in Abschnitt 5 des vorliegenden Handbuchs.

WARNUNG



Setzen Sie die Verriegelung des LF 6602 nicht außer Kraft, und öffnen Sie nicht beide Laufwerke gleichzeitig.

EINSCHALTVERFAHREN

HINWEIS

Die Seriennummer, die dem Laufwerk zugeordnet wird, muß mit den letzten 5 Ziffern der tatsächlichen Seriennummer des Laufwerks übereinstimmen, damit eine exakte interne Ereignisprotokollierung stattfinden kann. Die tatsächliche Seriennummer des Laufwerks befindet sich an der Rückseite des Laufwerksgehäuses.

EINSTELLEN DIE "DEICE ID"

HINWEIS

Schalten Sie das Laufwerk nach Rücksetzung der Geräteerkennung aus, warten Sie 1 Sekunde und schalten Sie das Laufwerk dann wieder ein. Dies stellt sicher, daß die neue Geräteerkennung vom SCSI-Bus anerkannt wird.

EINSTELLEN DIE "READ OPTION"

VORSICHT



Die Option "Read ahead" ist systemabhängig. Setzen Sie sich mit Ihrem Systemanalytiker in Verbindung, bevor Sie diese Option einstellen.

ANZEIGEN DER DIAGNOSEERGEBNISSE ODER DURCHFÜREN VON DIAGNOSERVERFAHREN

VORSICHT



Da die Initialisierungsvariablen nicht wiederhergestellt werden können, nachdem sie gelöscht wurden, sollte dieser Vorgang nur von einem ausgebildeten Ingenieur des Kundendienstes durchgeführt werden.

EINSTELLEN DER INTERNEN LAUFWERKSSERIENNUMMER ("SERIENNR. EINSTELLEN")

HINWEIS

Die Seriennummer, die dem Laufwerk zugeordnet wird, muß mit den letzten 5 Ziffern der tatsächlichen Seriennummer des Laufwerks übereinstimmen, damit eine exakte interne Ereignisprotokollierung stattfinden kann. Die tatsächliche Seriennummer des Laufwerks befindet sich an der Rückseite des Laufwerksgehäuses.

HANDHABUNG VON DATENTRÄGERKASSETTEN

Achten Sie bei der Handhabung und Lagerung von Datenträgerkassetten auf die folgenden Vorsichtsmaßnahmen, um die Datenintegrität zu sichern.

- 1) Die Datenträgerkassette niemals auf harte Flächen fallen lassen.
- 2) Das Kassettengehäuse oder den Zugriffsmechanismus nicht mißbrauchen.
- 3) Die Datenträgerkassette nicht im Laufwerk lagern.
- 4) Die Kassetten vor einem Transport aus dem Laufwerk entfernen.
- 5) Etiketten nur an den vorgesehenen Stellen anbringen. Anweisungen zum Anbringen von Etiketten befinden sich in Abschnitt 5.4.2.
- 6) Die Datenträgerkassette vor direkter Sonneneinstrahlung und Kondensation schützen.

VORSICHT



Zur Vermeidung einer Beschädigung der Datenträger wird dringendst empfohlen, die in der Spezifikation für LM 6000-Datenträger (Bestellnr. 97647044) angegebenen Umgebungsbeschränkungen sorgfältig zu beachten.

- 7) Die Datenträgerkassette nicht extremen Temperaturen aussetzen.
- 8) Die Datenträgerkassette eine Stunde vor Gebrauch auf den angegebenen Betriebstemperaturbereich stabilisieren.
- 9) Die Zugangsabdeckung des Datenträgers nicht öffnen.
- 10) Die Plattenoberfläche nicht durch die Zugangsabdeckung berühren.
- 11) Die Magnetplatte nicht aus der Kassette herausnehmen.

- 12) Die Datenträgerkassetten in einer sauberen Büroumgebung benutzen, handhaben und lagern.
- 13) Während der Handhabung von Datenträgern nicht rauchen. Asche und Tabak sind eine Hauptquelle für die Verunreinigung von Magnetplatten. Alle Rauchutensilien sind aus den Bereichen fernzuhalten, in denen Datenträger benutzt oder gelagert werden.
- 14) 14) Die Außenflächen der Kassetten sauber halten. Die Kassetten regelmäßig mit einem weichen, trockenen, fusselfreien Tuch reinigen. Weitere Informationen zur Pflege und Handhabung von Datenträgern finden Sie in der Spezifikation für den LM 6000-Datenträger (Bestellnr. 97647044).

WARNUNG



Setzen Sie die Verriegelung des LF 6602 nicht außer Kraft, und öffnen Sie nicht beide Laufwerke gleichzeitig.

VORSICHT



Wenn die Gebläsefilterelemente nicht sauber gehalten werden, kann die Luftzirkulation im Laufwerk beeinträchtigt werden. Dies kann zu einem übermäßigen Temperaturanstieg und damit zu einer Beschädigung der Laufwerke führen.

AUSWECHSELN VON SICHERUNGEN

Wie in Abschnitt 2.6. des vorliegenden Handbuchs dargestellt, sind zwei Sicherungen und zwei Ersatzsicherungen in die Netzbuchse an der Geräterückseite des LF 6600 eingebaut (vgl. Abbildung 40). Wenn sich das Laufwerk nicht einschalten läßt, könnte eine oder beide Sicherungen durchgebrannt sein.

So tauschen Sie eine durchgebrannte Sicherung gegen eine Ersatzsicherung aus:

- 1) Stellen Sie den Wechselstromschalter des Laufwerks auf AUS (0), und ziehen Sie das Netzkabel ab.
- 2) Fügen Sie einen kleinen Flachsraubenzieher zwischen dem Sicherungshalter und dem Gehäuse der Buchse ein (vgl. Abbildung 40).

- 3) Öffnen Sie den Sicherungshalter vorsichtig. Ziehen Sie den Sicherungshalter aus der Buchse heraus und überprüfen Sie die aktive Sicherung, um festzustellen, ob sie durchgebrannt ist. Wenn die Sicherung durchgebrannt ist, fahren Sie mit Schritt 4) fort, ansonsten mit Schritt 5).
- 4) Entfernen Sie die aktive Sicherung und entsorgen Sie sie. Nehmen Sie die Ersatzsicherung aus deren Aufbewahrungsort und fügen Sie die Sicherung zwischen dem Sicherungsgehäuse und der Halteklammer ein.
- 5) Installieren Sie den Sicherungshalter wieder in der Buchse; schieben Sie dabei den Halter in die Buchse, bis der Halter bündig auf das Gehäuse der Buchse ausgerichtet ist.
- 6) Wenn die Stromversorgung nicht wiederhergestellt wird, prüfen Sie die andere Sicherung.

WARNUNG



Sollte eine Ersatzsicherung unmittelbar nach dem Ersetzen der Originalsicherung entfallen, dürfen Sie diese Sicherung nicht mehr ersetzen.

Wenden Sie sich an die nächste Stufe technischer Unterstützung. Dies könnte das Symptom eines schwerwiegenden Problems sein, das entweder am Netzteil des Laufwerks oder in der Stromversorgung liegt.



Free Manuals Download Website

<http://myh66.com>

<http://usermanuals.us>

<http://www.somanuals.com>

<http://www.4manuals.cc>

<http://www.manual-lib.com>

<http://www.404manual.com>

<http://www.luxmanual.com>

<http://aubethermostatmanual.com>

Golf course search by state

<http://golfingnear.com>

Email search by domain

<http://emailbydomain.com>

Auto manuals search

<http://auto.somanuals.com>

TV manuals search

<http://tv.somanuals.com>