

PSW1200

PSW1200

**Instruction
Manual**

polkaudio
The Speaker Specialists[®]

IMPORTANT— READ THIS MANUAL

WE KNOW YOU ARE ANXIOUS TO PLUG IN YOUR HOT NEW TOY (THIS SUB) AND LET 'ER RIP. BUT IF YOU FULLY UNDERSTAND ALL THE HOOK-UP OPTIONS AND THEIR IMPLICATIONS, YOU WILL ULTIMATELY GET BETTER PERFORMANCE FROM YOUR SYSTEM.

PSW1200 OWNERS MANUAL

Table of Contents

PSW1200 features	4
Subwoofer placement	4
Connecting the subwoofer (general)	5
Bass management/ speaker setup	5-8
Inputs and outputs	9-15
Hook up options chart	16-17
AC Power controls	19
Subwoofer adjustments	19-20
Maintenance	21
Hum	21
Technical assistance	21
Specifications	22
Warranty	23

POLK AUDIO LIMITED WARRANTY

Polk Audio, Inc., warrants to the original purchaser only that the **Amplifier** in this Polk Audio Loudspeaker Product (the "Product") will be free from defects in material and workmanship for a period of three (3) years from the date of original retail purchase from a Polk Audio Authorized Dealer. Polk Audio, Inc., further warrants to the original purchaser only that the **Loudspeaker(s)** in this Polk Audio Product (the "Product") will be free from defects in material and workmanship for a period of five (5) years from the date of original retail purchase from a Polk Audio Authorized Dealer. The original retail purchaser shall hereinafter be referred to as "you." However, this Warranty will automatically terminate prior to the expiration if you sell or otherwise transfer the Product to any other party. To allow Polk Audio to offer the best possible warranty service, please fill out the Product Registration Card(s) and send it to the Factory, at the address provided on the Product Cards(s) within ten (10) days of the date of purchase.

Defective Products must be shipped, together with proof of purchase, prepaid insured to the Polk Audio Authorized Dealer from whom you purchased the Product, or to the Factory at 2550 Britannia Boulevard, Suite D, San Diego, California 92173. Products must be shipped in the original shipping container or its equivalent; in any case the risk of loss or damage in transit is to be borne by you. If upon examination at the Factory or Polk Audio Authorized Dealer it is determined that the unit was defective in materials or workmanship at any time during this Warranty period, Polk Audio or the Polk Audio Authorized Dealer will, at its option, repair with new or reconditioned parts or replace this Product at no additional charge, except as set forth below. All replaced parts and Products become the property of Polk Audio. Products replaced or repaired under this warranty will be returned to you, within a reasonable time, freight prepaid.

This warranty does not include service or parts to repair damage caused by accident, disaster, misuse, abuse, negligence, inadequate packing or shipping procedures, commercial use, voltage inputs in excess of the rated maximum of the unit, cosmetic appearance of cabinetry not directly attributable to defect in materials or workmanship, or service, repair, or modification of the Product which has not been authorized or approved by Polk Audio. This warranty shall terminate if the Serial number on the Product has been removed, tampered with or defaced.

This warranty is in lieu of all other expressed Warranties. If this Product is defective in materials or workmanship as warranted above, your sole remedy shall be repair or replacement as provided above. In no event will Polk Audio, Inc. be liable to you for any incidental or consequential damages arising out of the use or inability to use the Product, even if Polk Audio, Inc. or a Polk Audio Authorized Dealer has been advised of the possibility of such damages, or for any claim by any other party. Some states do not allow the exclusion or limitation of consequential damages, so the above limitation and exclusion may not apply to you.

All implied warranties on this Product are limited to the duration of this expressed Warranty. Some states do not allow limitation on how long an implied Warranty lasts, so the above limitations may not apply to you. This Warranty gives you specific legal rights, and you also may have other rights which vary from state to state.

This Warranty applies only to Products purchased in the United States of America, its possessions, and U.S. and NATO armed forces exchanges and audio clubs. The Warranty terms and conditions applicable to Products purchased in other countries are available from the Polk Audio Authorized Distributors in such countries.

"Polk Audio," "The Speaker Specialists," and "Power Port"
are trademarks of Britannia Investment Corporation used under license by Polk Audio Incorporated.

SPECIFICATIONS

PSW1200

Driver Complement
2-12" woofers

Continuous average power*:
230 watts into 8 ohms @1% THD
over power bandwidth of 30-120Hz

Dynamic Power Rating* -
350 watts into 8 Ohms

System Acoustic Efficiency -
90db from 1 watt at 1 meter

Calculated Maximum Output -
115db at 1 meter

Enclosure Type
Direct radiating, vented

Port Type
Power Port

Frequency Response: Overall +/- 3db Limits
20Hz -140Hz /22Hz -125Hz

Lowpass Crossover Frequency
Adjustable 40Hz -120Hz

Phase Control
Variable 0° to 180°

Inputs
Speaker and line level

Outputs
Speaker and line level

High Pass Filters
Line Level Outputs:
Switchable 40Hz or
80Hz, 12db/octave
Speaker Outputs:
Switchable: Flat, 40Hz or 80Hz

Shipping Weight
110 lbs/ea (49.9 kg)

Dimensions
26½"H x 18¾"W x 23¾"D
67.3cmH x 47.6cmW x 60.3cmD

* About Power Ratings

When making comparisons between product specifications it helps to understand what they mean, particularly with amplifier power ratings. The Federal Trade Commission has recently issued new regulations regarding the power ratings of all amplifiers including self-powered speakers. Polk Audio supports this effort to standardize power testing methods in order to provide consumers with a "level playing field" basis for comparison. Make sure the basis for the power rating is clearly stated before comparing it to another product's specification.

The FTC rating is based on the continuous power output of the amplifier. However, music and movies are not continuous but are mainly composed of short bursts of sound. For this reason we also supply a "Dynamic Power" rating which measures the ability of the amplifier to produce power in short bursts similar to those found in music and movies. In our experience an amplifier with higher Dynamic Power output will play louder under most conditions regardless of the continuous power rating. Dynamic Power is typically greater than continuous average power although it is not uncommon for two amplifiers with identical FTC "Continuous Average" ratings to have very different Dynamic Power performance.

However, loudspeaker efficiency is by far the most important factor in determining how loud your system will play. Loudspeaker efficiency is usually given as the amount of sound produced by 1 watt at a distance of 1 meter. A medium efficiency loudspeaker rating would be around 87 dB from 1 watt at 1 meter. A highly efficient loudspeaker might be 90 dB. Each 3dB increase in efficiency doubles the sound output for a given power input. So a 100 watt, 90 dB self-powered speaker and a 200 watt 87 dB unit would produce the same sound output. For this reason we also specify the loudspeaker efficiency and calculated maximum sound output.

Polk Audio and the Consumer Electronics Manufacturer's Association are currently engaged in an effort to set standards for specifying the actual acoustic output of self-powered speakers. If we are successful, consumers will be able to use these ratings to make more meaningful product comparisons and better purchasing decisions in the future.

POLK AUDIO - A HISTORY OF EXCELLENCE

Matthew Polk and George Klopfer founded Polk Audio in 1972. Their dream was to make high performance speakers at reasonable prices. Today Polk Audio is still headquartered in Baltimore, Maryland, and is one of the world's largest manufacturers of loudspeakers for home, office and car. Polk's research has yielded over 20 patents for advances in loudspeaker performance and value. Polk speakers have earned the praise of audio experts the world over, as well as dozens of awards for innovative, high-quality design. Polk Audio speakers are sold in over 50 countries and in audio/video specialist retail locations throughout the U.S.

A WORD FROM MATTHEW POLK

Dear Music Lover,

Thank you for purchasing Polk Audio speakers. Designing and building speakers is more than just a business for the people of Polk Audio—it is our passion. We are all dedicated to your complete satisfaction and delight.

Your new Polk subwoofer includes the latest loudspeaker technology to assure outstanding performance and unmatched quality. Please take a moment to read this manual; when you fully understand all the hook-up options and their implications, you will ultimately get better performance from your system.

We also make a variety of main, center, rear channel and accessory speakers so you can assemble a complete and well matched high-performance surround sound system. If you would like more information on building the Polk system of your dreams, consult your Polk Audio dealer or call our Customer Service Department. In North America call (800) 377-7655, Monday through Friday, 9:00 AM through 6:00 PM Eastern Time.

Sincerely,



Matthew S. Polk
Chairman and Co-Founder

P.S. A wealth of information can also be found on our award-winning web site: www.polkaudio.com.



FEATURES:

- Two 12-inch direct radiating smooth response subwoofer drivers.
- Power Port™ patented bass port for deep bass with low distortion.
- High-current 350 watt power amplifier.
- 7 low level input channels—left front, right front, center, subwoofer, LFE, left rear and right rear—to allow connection of every channel's output to the subwoofer. There is never a question whether or not all the bass on your recording is getting to your PSW1200 subwoofer!
- Front panel volume control
- Variable low-pass crossover and variable phase controls allow you to optimize performance to match your audio system, room acoustics, and program material
- Auto movie detect and bass boost. (When the center channel input senses a signal, it automatically boosts the overall subwoofer level by 3dB)
- Auto on/off circuit that automatically turns your Subwoofer on when it senses a program signal. When no signal is present, the amplifier turns itself off within 15 minutes
- Unfiltered LFE/Subwoofer input for use with low pass filtered subwoofer output jacks
- Speaker and line level inputs and outputs
- Switchable high-pass filters. When passed through the PSW1200, main channel signals may be high pass filtered at either 40Hz or 80Hz from both line or speaker level outputs

GETTING STARTED

Please inspect your subwoofer and its drivers carefully. Notify your Polk dealer if you notice any damage or missing items. Keep the carton and packing material. They will do the best job of protecting your PSW1200 if it needs to be transported.

PLACEMENT

The Polk PSW1200 subwoofer may be placed anywhere in the room, but for the greatest possible bass output, place the subwoofer near a corner of the room. Due to a room acoustics phenomenon called "standing waves," bass response may be uneven throughout a room. In some areas of the room, the bass will be very loud, in others very weak. Experiment with subwoofer placement to find the location that yields the deepest, tightest bass in your favorite listening position.

FIGURE 1a.

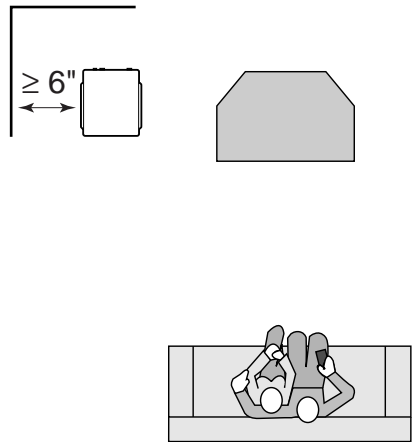

Allow at least 6 inches (15cm) of space between any subwoofer driver and a wall or obstruction. (**Fig. 1a**).

optimal phase tuning.

MAINTAINING THE APPEARANCE OF YOUR PSW 1200

Your new speaker cabinet is finished in woodgrain vinyl that can be dusted or cleaned with a moist soft cloth. Avoid harsh detergents and cleaning fluids, they can permanently damage your speaker's finish. Remove grilles and gently vacuum the dust.

Q. "WHY DOES MY SYSTEM HUM?"

A. "It doesn't know the words."

This is what passes for humor in the audio business. Here is the real answer:

If you have any electrical 60Hz hum in your system, you are more likely to hear it once you hook up your Subwoofer. Most hum problems are caused by ground loops. That is, the electrical grounds of the components in your system are not at the same electrical potential. A very common ground loop source is cable TV. Disconnect the coaxial cable from your TV and/or VCR. If the hum goes away, the cable is the ground loop villain. In that case, you need a 75-ohm ground loop isolator. This device is about the size of a pen and is attached to your coaxial cable where it plugs into your VCR (or television). You can obtain this device from some audio dealers, Radio Shack stores,

Zantech (1-800-843-5465) or Channel Plus (1-800-99-5225).

Ground loops and hum can also be the result of faulty electrical wiring in your home. Consult a licensed electrician to evaluate and, if necessary, repair the AC wiring in your home. Light dimmers also tend to introduce noise into audio systems. Remove them.

If none of our suggestions work for you, call our customer service number shown below.

TECHNICAL ASSISTANCE OR SERVICE

If, after following the hook-up directions, you have trouble, please double-check all wire connections. If the problem is that you are not getting enough bass, make sure the AC cord is connected to a live AC power source and that the power switch is set to the "on" or "auto" position. Should you isolate the problem to the speaker, contact the authorized Polk Audio dealer where you made your purchase. Authorized Polk Audio dealers are the best source for advice and assistance.

Our cheerful customer service representatives are happy to answer your questions and provide fast, friendly service. In North America call (800) 377-7655, Monday through Friday, 9:00 AM through 6:00 PM Eastern time.

FIGURE 18.

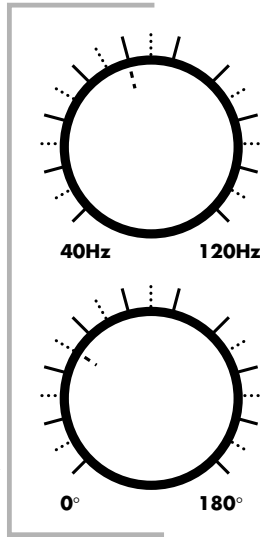
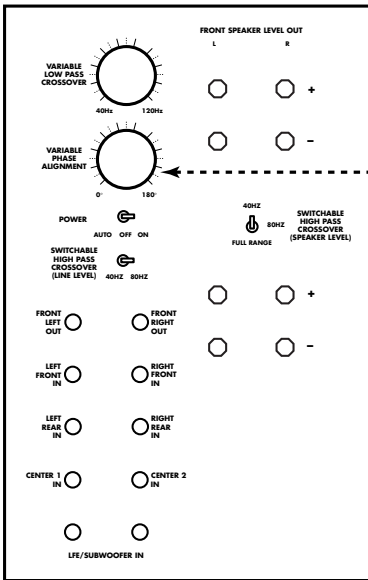

VARIABLE LOW PASS CROSSOVER (Fig. 18)—This control adjusts the frequency range over which the Subwoofer operates. This control only affects signals that are sent through the Front, Center and Rear line level “In” jacks and the Speaker Level Inputs. *It has no effect on signals fed into the LFE/Subwoofer input.* When using smaller main speakers, the upper range of the control will probably yield the best results. With larger speakers, the lower end of the control range will probably sound best, but always let your ear be the final judge. After setting subwoofer levels, you may want to

experiment with the crossover frequency setting. Turning the knob up will add more “warmth” to the bass and lower midrange, possibly at the expense of bass “tightness” and midrange clarity. Turning the knob down will make the bass and lower midrange sound “thinner.” Experiment and set this control to taste.

VARIABLE PHASE ALIGNMENT (Fig. 18)—Have someone else turn the knob slowly while you sit in your favorite listening position. Use music with good bass and a deep male vocal. When you hear the best balance of deep bass and the natural lower octaves of the male voice, you have achieved

The subwoofer should be placed only on its integrated Power Port™ base.

(Fig. 1b) NEVER LAY THE SUBWOOFER ON THE AMPLIFIER END – THIS WILL DAMAGE THE AMPLIFIER.

FIGURE 1b.



The PSW1200 is not magnetically shielded and should not be placed close to a television set. If you see any color distortion in your TV, move the subwoofer a few inches farther from the set.

CONNECTING THE SUBWOOFER TO THE SYSTEM—GENERAL

The PSW1200 was designed to allow you to get the maximum bass performance from your stereo or home theater system, regardless of the type of equipment you have. Due to the broad range of equipment available, and the versatility of the PSW1200, we are not able to describe every possible hook up method. Start by understanding the issues and the capabilities of the PSW1200. From there, you should be able to determine the hook up method that is perfect for you.

WHAT ARE THE GOALS?

The first goal is to make sure that all the bass information on the recording gets to your speakers. Second, that the bass gets to the speakers that are best suited to reproduce it. And third that all the speakers in the system “blend” per-

fectly. A poor blend will sound unnatural; you will be aware that the main and subwoofer speakers are separate units. In a well-blended system, the subwoofer will not call attention to itself; you will simply hear a lot more deep, tight, exciting bass. Experiment with alternate hook-up methods to find the one that works best for you.

WHAT IS BASS MANAGEMENT AND HOW DO I USE IT?

Bass management involves moving bass signals from one speaker to another. For example, if you have a speaker that is not well suited to reproducing loud deep bass, bass management allows you to move that channel’s bass to another speaker—generally to the subwoofer. The PSW1200 has some built-in bass management features for those systems that have no bass management facility at all, or for those whose facilities are inadequate for your needs.

Stereo receivers and preamps never have bass management facilities. If you have a stereo-only system, go immediately to page 9. Dolby Pro Logic® receivers and processors usually have minimal bass management facilities. Dolby Digital® processors always have bass management features but the capabilities and operation may vary from model to model.

The bass management system function in your receiver or processor is usually accessed through an on-screen display and may be called “Speaker Set-Up.” Some units use switches on the front and/or rear panels. Read your electronics’ owner’s manual to learn how to access your bass management/speaker setup features. Here is a list of the terms and choices you will find, and how they operate:

BASS MANAGEMENT/SPEAKER SETUP SETTINGS

DOLBY PRO LOGIC

Wide—(center speaker only) The center speaker is sent a full-range signal: all the sounds that are on that channel will go to the center speaker.

Normal—(center speaker only) Bass frequencies below 100Hz are filtered out of the center channel and sent to the Front and Subwoofer outputs.

Phantom—(center speaker only) Not part of the bass management/speaker setup system at all. This simply sends all the center information into the front speakers.

Subwoofer Output Jack—In Pro Logic units this output is nothing more than summed left and right front channels with a low pass (lets only bass through) filter, usually fixed at 80Hz. Because a fixed filter negates the Variable Low Pass Crossover function, one of your main bass “tuning” tools, you shouldn’t use this output *unless it is unfiltered*. See page 13 for information on filtered and un-filtered outputs.

THX Variation—In THX certified Pro Logic receivers and processors, the front main speakers can also be selected as WIDE (LARGE) or NORMAL (SMALL). When selected as NORMAL (SMALL), the bass is filtered out of the front channels and sent to the subwoofer output jack.

DOLBY DIGITAL AND DTS®

Dolby Labs mandates that Dolby Digital-processor equipped electronics must offer “all channels small” and “all channels large” options, but beyond that there are no standards. Most units allow any combination of “Large / Small” choices for Front, Center and Surround channels, but not all do. In such cases, the PSW1200 allows you to overcome that limitation.

Large—When you select a speaker as “Large” that speaker will be sent a full-range signal: all the sounds that are on that channel will go to that speaker.

Small—Most often Center and Surround channels are small, bass-limited speakers and are set to “Small.” When you select a speaker as “Small,” frequencies below a certain point (usually 80Hz) are taken out and sent somewhere else. Where does that bass go? It will go to the subwoofer output jack if that jack is turned “On” (see below). If the subwoofer output jack is “Off,” the bass should go to the front Left and Right channel outputs. If you select Front speakers as “Small” and Subwoofer “Off” you are going to lose a lot of bass.

Subwoofer Yes (ON) / No (OFF)—

This determines whether the subwoofer output jack is fed signal. If it is “Off,” any bass redirected from other channels and the LFE-channel bass should go to the Front L&R outputs.

SMALL AND LARGE DECISION MAKING

Most of the time this choice is easy to make. A very small bookshelf or on-wall speaker should always be selected as Small. A main speaker with built-in powered subwoofers should be selected as Large. Sometimes this choice is not so clear cut. Is a “beefy” bookshelf speaker like a Polk RT55 “small” or “large”? Is it good or bad to have such a speaker play bass?

“Small” Advantages

- By rolling off the bottom end (taking out the bass) of a speaker, it can play a lot louder, with less distortion. If you play your system very loud, and your speakers are not full-range behemoths, this is the right choice for you
- The midrange will be clearer and better defined

FIGURE 16.

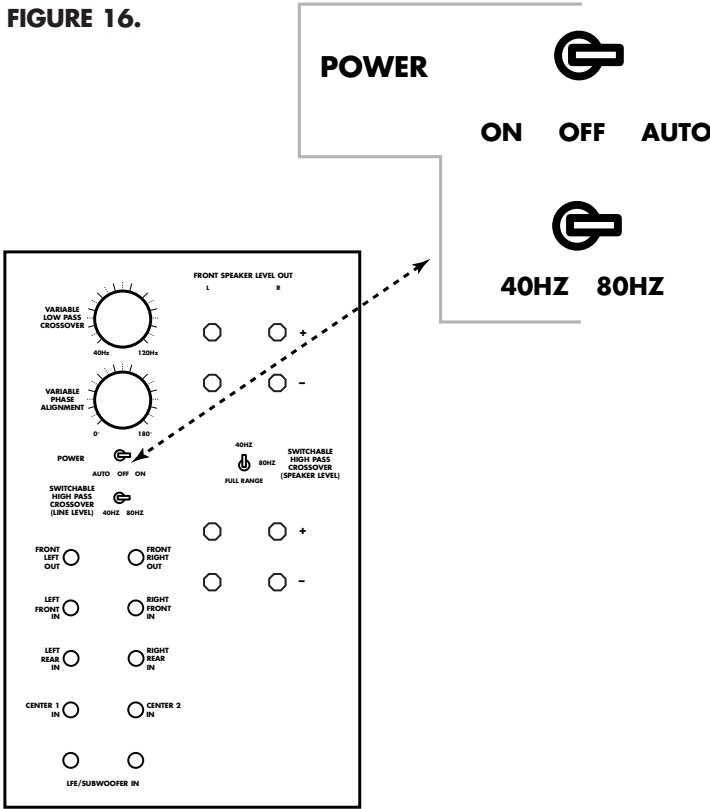

the one that's right for you.

AC POWER

The PSW1200 has a built-in power amplifier and must be plugged into a standard household 110-120V AC power source in order to operate.

The power switch has three positions: "On," "Off" and "Auto" (Fig. 16). In the "Auto" position, the amplifier will automatically turn on, and the green pilot light on the front of the subwoofer will illuminate, as soon as the speaker senses a signal coming from your electronics. The amplifier and the green pilot light will turn off approximately 15 minutes after input signal ceases. In the "On" position, the power amplifier will operate and the green pilot light will illuminate until the switch is set to "Off" position or the AC cord is disconnected

from a power source.

SUBWOOFER ADJUSTMENTS

SUBWOOFER LEVEL CONTROL

Subwoofer level is adjustable via the knob on the front of the subwoofer under the logo pod (Fig. 17). Play a piece of music that has an average amount of bass content. Adjust by ear using a variety of CDs and video sources. Adjust for deep, powerful bass, avoiding "boominess."

FIGURE 17.



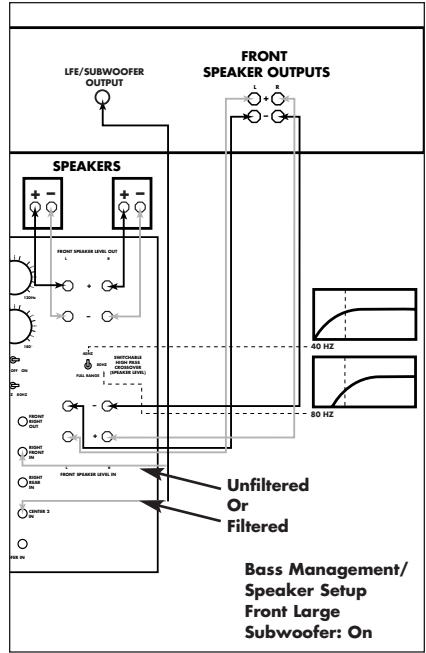
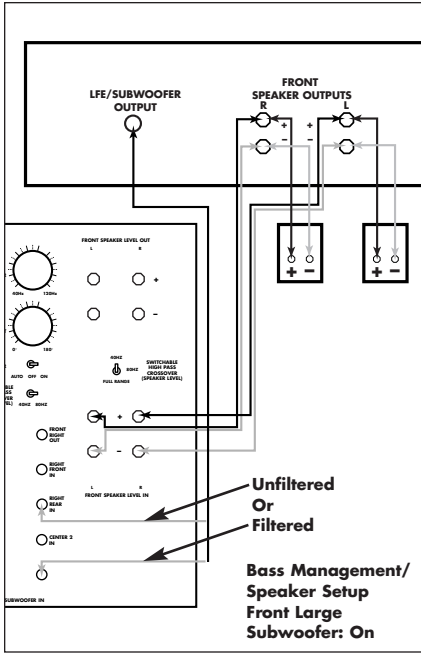

FIGURE 14.

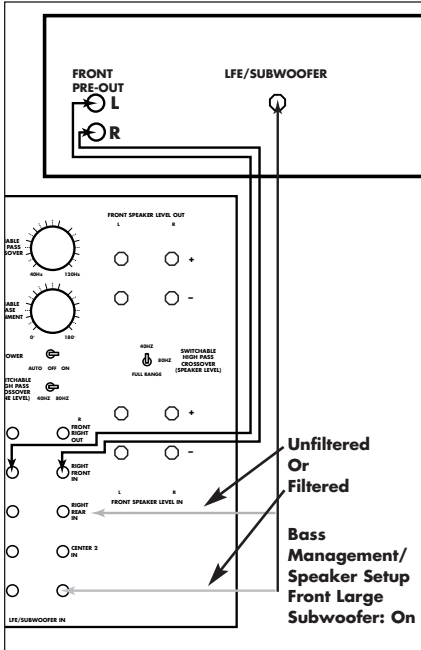
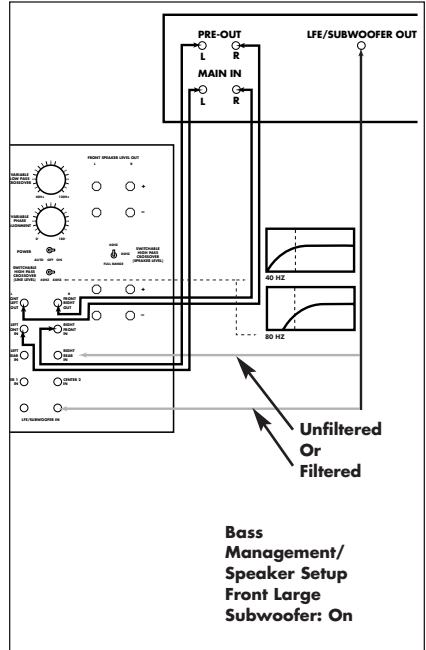

FIGURE 15.



“Large” Advantages–

- You will probably get better blending between main speaker and subwoofer.
- The bass “attack” or “tightness” may be better
- Imaging may be more even, seamless and natural

HOW THE PSW1200 CAN HELP

If your system has no bass management/speaker setup feature or if it does not meet your needs, the PSW1200 can help. For example, if you are torn between setting your front main speak-

ers as “Large” or “Small”, you can use the high pass filters on the PSW1200 to roll off their response at 40 Hz instead of relying on the fixed 80 Hz filter in your receiver or processor.

Here’s another example: you have a large full-range Center speaker like the Polk CS1000p. You want it to play Center bass frequencies (for better imaging) and you *also* want to send those Center bass frequencies to the Subwoofer (to get better system impact). But if you set your center to “Large” and you hook up the Subwoofer

FIGURE 2. RECEIVER OR PROCESSOR

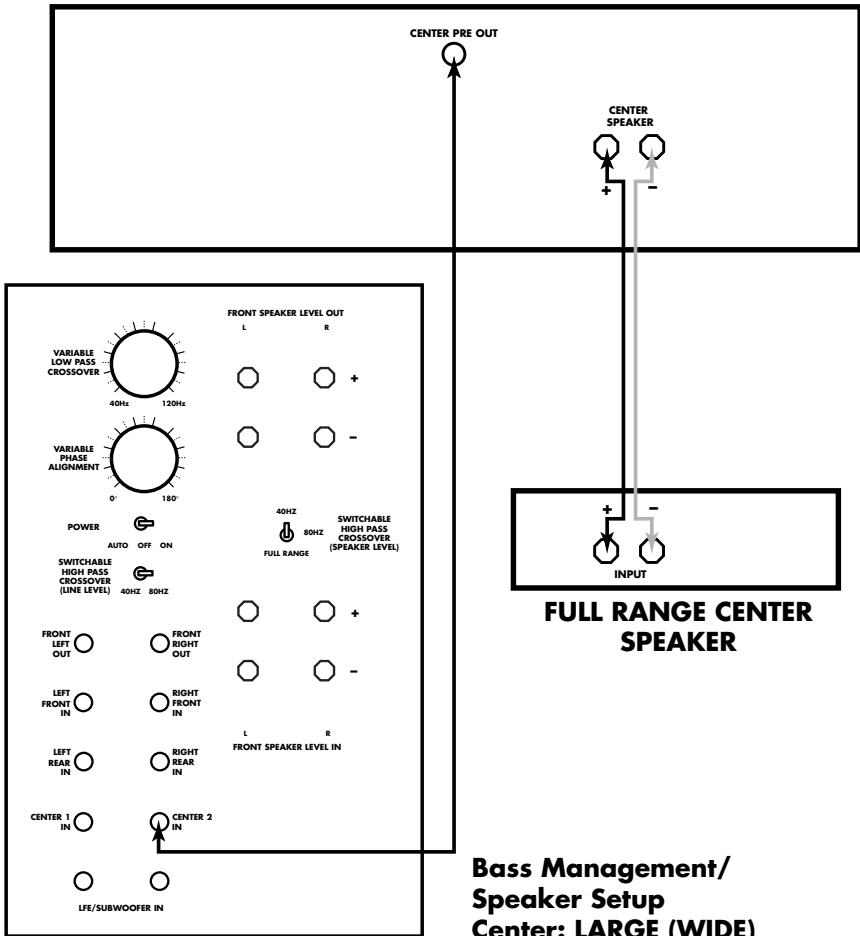
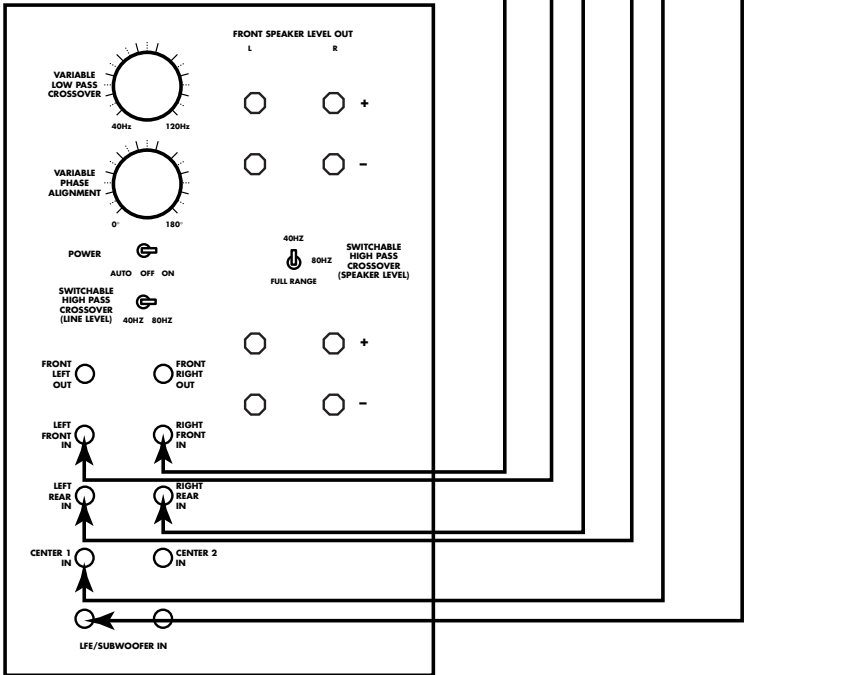

FIGURE 3.

**DOLBY DIGITAL / DTS
RECEIVER OR PROCESSOR**

**Bass Management/
Speaker Setup**
Front: Large
Center: Large
Surround: Large
Subwoofer: Yes



to the Subwoofer output jack, the Center bass would not go to the Subwoofer. In this case, you can select your Center as "Large" and hook up the center channel output *directly* to the Center channel input of the PSW1200.

(Fig. 2, previous page)

Now you have it all!

In fact, the PSW1200 has enough inputs to accept every channel of a 5.1 surround system. If you want to make sure

you get the bass from every channel through your Subwoofer, simply plug in the preamp output from each channel directly into the PSW1200. No guesswork and no lost bass information.

(Fig. 3)

The Front, Rear, and Center, etc., labels on the PSW1200's inputs and outputs are just there for convenience. There is no reason why you cannot use a given set of jacks for another channel. For example, assume you want to roll off the

DOLBY DIGITAL AND DTS

Bass Mngt./ Speaker Settings

Option #	Equipment	Main Speakers	PSW Input	PSW Output	Use Sub/LFE Out?	HI PassFilter	Benefits	Illustration
1a	No preamp outputs	Large	Front Speaker Level In Front Large/Subwoofer On	Direct (none)	Yes (use LFE in if filtered output, Line In if not) See page 13	none	Very easy to hook up, low susceptibility to hum and noise.	Figure 12 Page 18
1b		Medium	Front Speaker Level In Front Large/Subwoofer On	Front Speaker Level Out	Yes (use LFE in if filtered output, Line In if not) See page 13	40Hz	Same as 1a plus improves main speakers power handling and lowers distortion	Figure 13 Page 18
1c		Small	Front Speaker Level In Front Large/Subwoofer On	Front Speaker Level Out	Yes (use LFE in if filtered output, Line In if not) See page 13	80Hz	Same as 1b	Figure 13 Page 18
2a	Preamp outputs	Large	Front Line In Front Large/Subwoofer On	n/a	Yes (use LFE in if filtered output, Line In if not) See page 13	Full Range	Amplifier colorations and distortions are not passed on to the Subwoofer—a little cleaner.	Figure 14 Page 18
2b		Medium	Front Line In Front Large/Subwoofer On	Front Line Out	Yes (use LFE in if filtered output, Line In if not) See page 13	40Hz	Same as 2a plus improves main speaker power handling and lowers distortion while maintaining good main/sub blending	Figure 15 Page 18
2c		Small	Front Line In Front Small/Subwoofer On	Front Line Out	Yes (use LFE in if filtered output, Line In if not) See page 13	80Hz	Same as 2b	Figure 15 Page 18

HOOK-UP OPTIONS

The PSW1200 offers a wide range of hook-up and use options. Each option has advantages and potential downsides. The option that is best for you depends on your electronics, Your main speakers, and your personal taste. The hook-up method you use will have a large impact on the "blending" between your main Front speakers and the Subwoofer. Read all the options before selecting

STEREO AND PRO LOGIC									
Option #	Equipment	Main Speakers	Bass Mngt./ Speaker Settings	PSW Input	PSW Output	Use Sub/LFE Out?	Hi Pass Filter	Benefits	Illustration
1a	No preamp outputs	Large	n/a	Front Speaker Level In	Direct (none)	No	none	Very easy to hook up, low susceptibility to hum and noise.	Figure 10 Page 15
1b		Medium	n/a	Front Speaker Level In	Front Speaker Level Out	No	40Hz	Same as above plus improves main speaker power handling and lowers distortion.	Figure 9 Page 14
1c		Small	n/a	Front Speaker Level In	Front Speaker Level Out	No	80Hz	Same as above.	Figure 9 Page 14
2a	Preamp Outputs	Large	n/a	Front Line In		No	n/a	Amplifier colorations and distortions are not passed on to the subwoofer—a little cleaner.	Figure 5 Page 10
2b		Medium	n/a	Front Line In	Front Line Out	No	40Hz	Same as above plus improves main speaker power handling and lowers distortion.	Figure 6 Page 11
2c		Small	n/a	Front Line In	Front Line Out	No	80Hz	Same as above.	Figure 6 Page 11

FIGURE 4.

RECEIVER OR POWER AMP

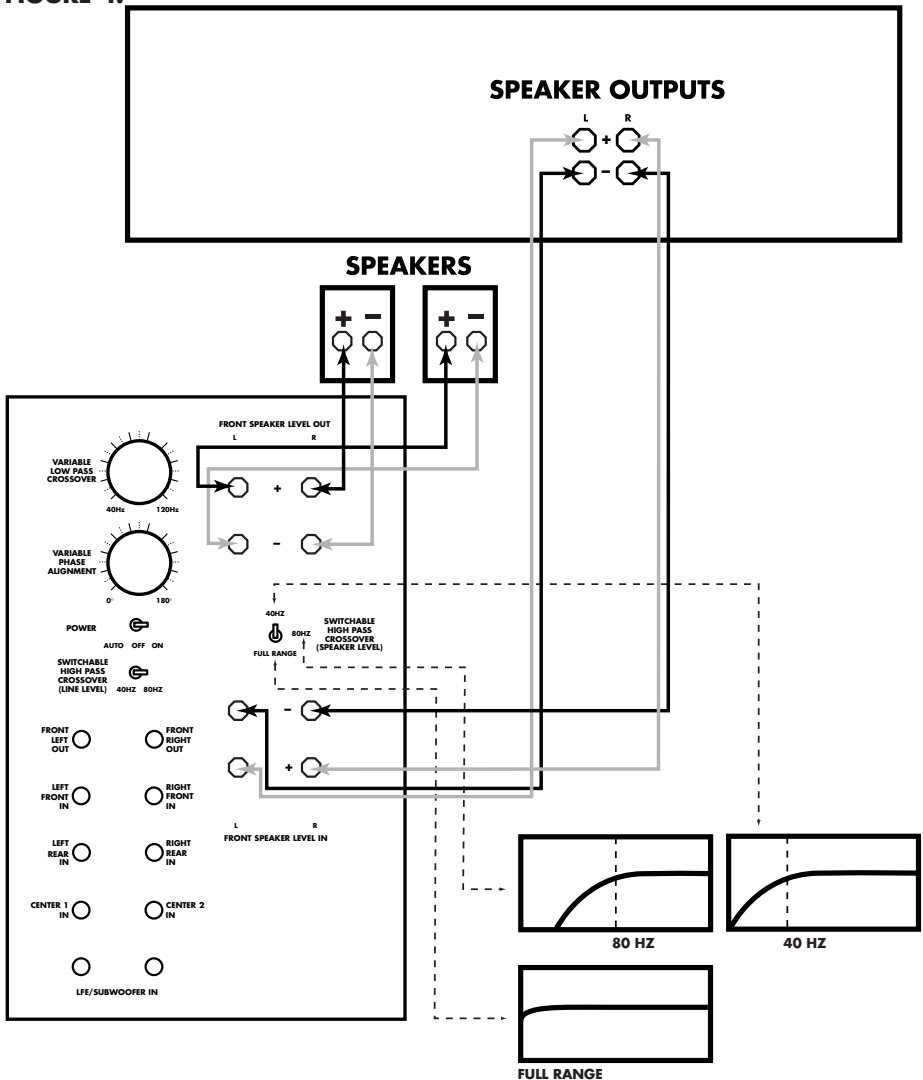

bottom end of the Rear speakers at 40Hz. Simply use either the Front Line Level or Front Speaker Level in/out sets to do that (assuming they are not already in use). Be creative.

PSW1200 INPUT AND OUTPUT FEATURES AND USE

Front Speaker Level In—Although these are labeled “Front,” they can be used for any channel. If your equipment does

not have—or if you do not wish to use—preamp level outputs to drive your Subwoofer, you can deliver signal via speaker wire (Fig. 4). The signal will pass through the Variable Low Pass Crossover.

FRONT SPEAKER LEVEL OUT—These may be used to route signal to speakers, especially if you want the PSW1200 to filter bass frequencies out of those speakers. (Fig. 4)

SWITCHABLE HIGH PASS CROSSOVER (Speaker Level)—If you want to filter bass out of any speaker, connect the Speaker Level In and Out, and select either 40Hz or 80Hz. Use 40Hz for larger speakers, 80Hz for smaller speakers. This feature is useful if you have a stereo or Pro Logic system that has no bass management/speaker setup system and you want to filter bass out of your main speakers. If you do not want to filter out any bass, select Full Range. (See Fig. 4, previous page)

FRONT LINE IN—Any set of preamp outputs may be connected here, but usually Front channel outputs. The signal will pass through the Variable Low Pass Crossover. If you do not have a spare set of pre-outs use a Y connector. (Fig. 5)

FIGURE 5.

DOLBY DIGITAL / DTS RECEIVER

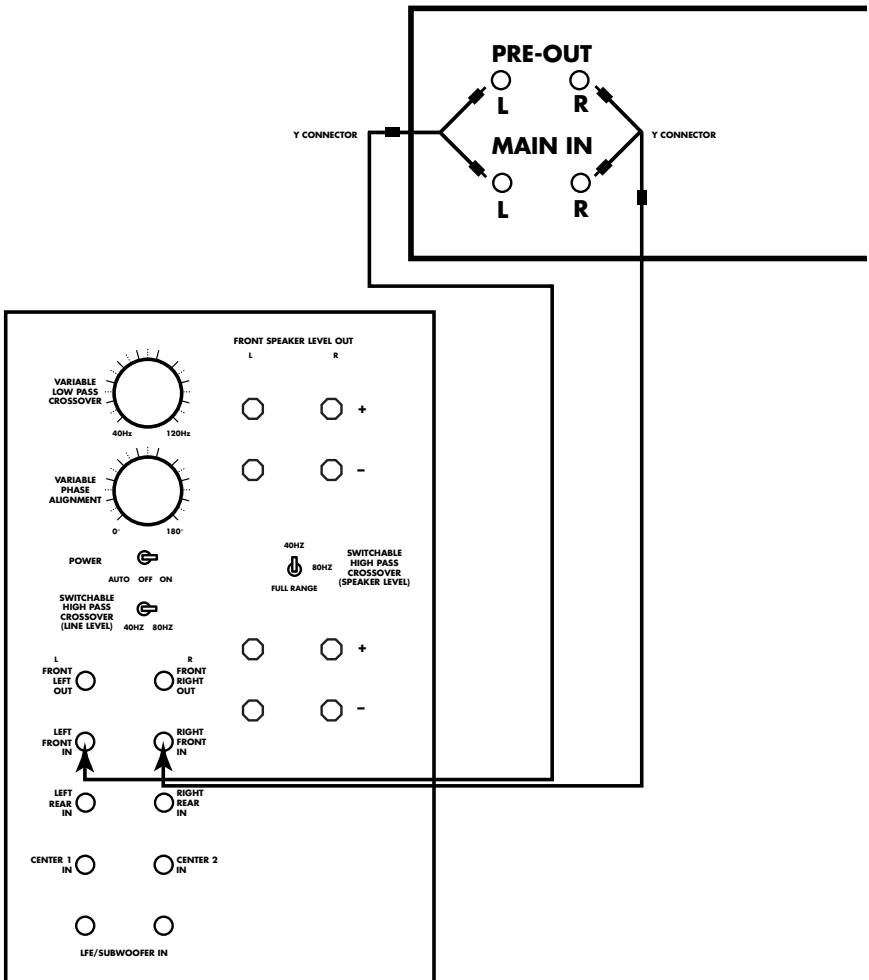

FIGURE 10. SURROUND RECEIVER OR PREAMP/PROCESSOR

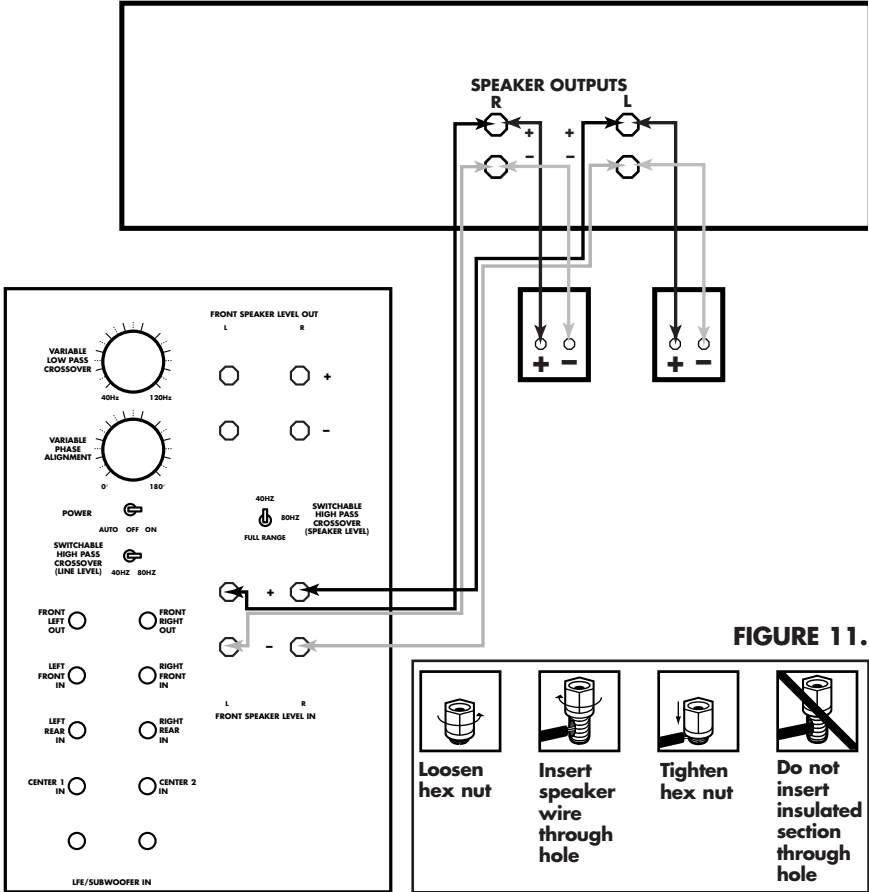
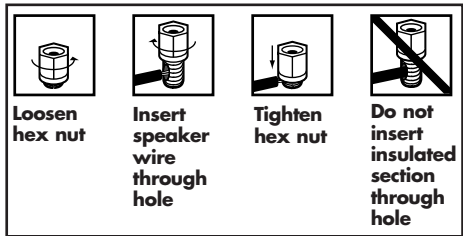

FIGURE 11.



your amplifier to the red (+) terminal on your speaker, and the wire from the black (-) terminal of the amplifier to the black (-) terminal on your speaker. Most wire has some indication (such as color-coding, ribbing, or writing) on one of the two conductors to help maintain consistency. If your Subwoofer does not seem to produce much bass, it is most likely that one of the speaker wires is connected backwards. Double-check all connections for correct polarity.

Strip 1/2" of insulation from each of the two conductors on both ends to expose the bare wire. Twist the exposed wire of each conductor to form two un-frayed

strands. Connect two conductors to the receiver or amp (refer to the owner's manual supplied with your electronics for assistance with proper hookup). Connect the two conductors on the other end of the wire to the speaker terminals. Repeat for the other channel. To connect wire to the binding post, unscrew the plastic hex nut on the binding post and insert the bare wire into the hole near the base of the binding post (**Fig. 11**). Do not insert the insulated part of the wire into the hole, as this will not give you a good connection. Twist the hex nut back down the binding post until it firmly meets the wire. Do not over-tighten.

FIGURE 9.

RECEIVER OR POWER AMP

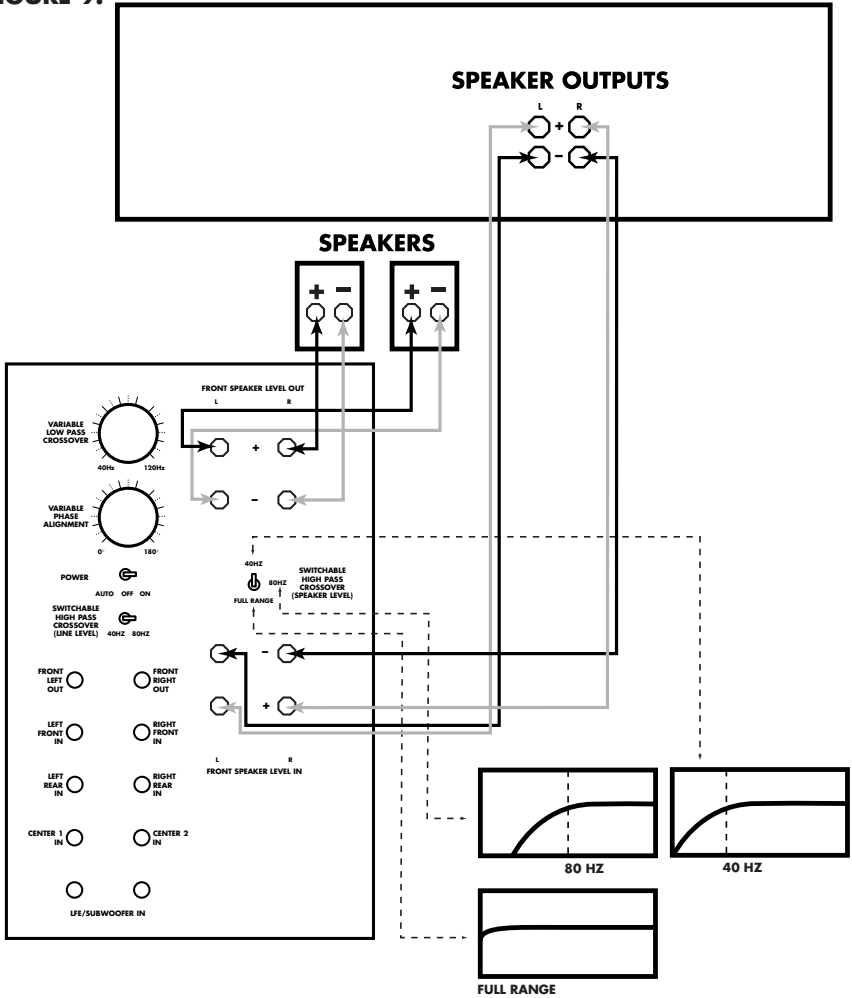

SPEAKER CONNECTIONS

Speaker level hook up is often the most convenient method and may yield the best results, especially if the subwoofer is placed far from your electronics. Speaker wires are a lot less susceptible to picking up hum and noise than are long RCA cables.

Connect the speaker outputs of your receiver or power amplifier to the Speaker Level In binding posts of the

PSW1200. You may connect your main speakers either to the Speaker Level Out binding posts of the PSW1200 (**Fig. 9**) or directly to your receiver or amp (**Fig. 10 next page**).

Use 2-conductor 16 gauge or thicker speaker wires. See your Polk dealer for wire recommendations. Note that one of each set of Speaker Level Input terminals is marked red (+) and the other black (-). Make certain that you connect the wire from the red (+) terminal of

FRONT LINE OUT—Connect these to the power amp (main) inputs only if you want a high pass filtered signal (selectable 40Hz or 80Hz) to go into the amplifier (**Fig. 6**). The filter cannot be defeated.

SWITCHABLE HIGH PASS CROSSOVER—(*Line Level*)—This selects the filter (crossover) frequency at either 40Hz

or 80Hz at 12dB/octave (**Fig. 6**).

REAR LINE IN - Connect rear line level preamp outputs here (**Fig. 7 next page**). The signal will pass through the Variable Low Pass Crossover. Use Y connectors if you need to have these pre-outs connected to a power amplifier or Main In jacks.

FIGURE 6.

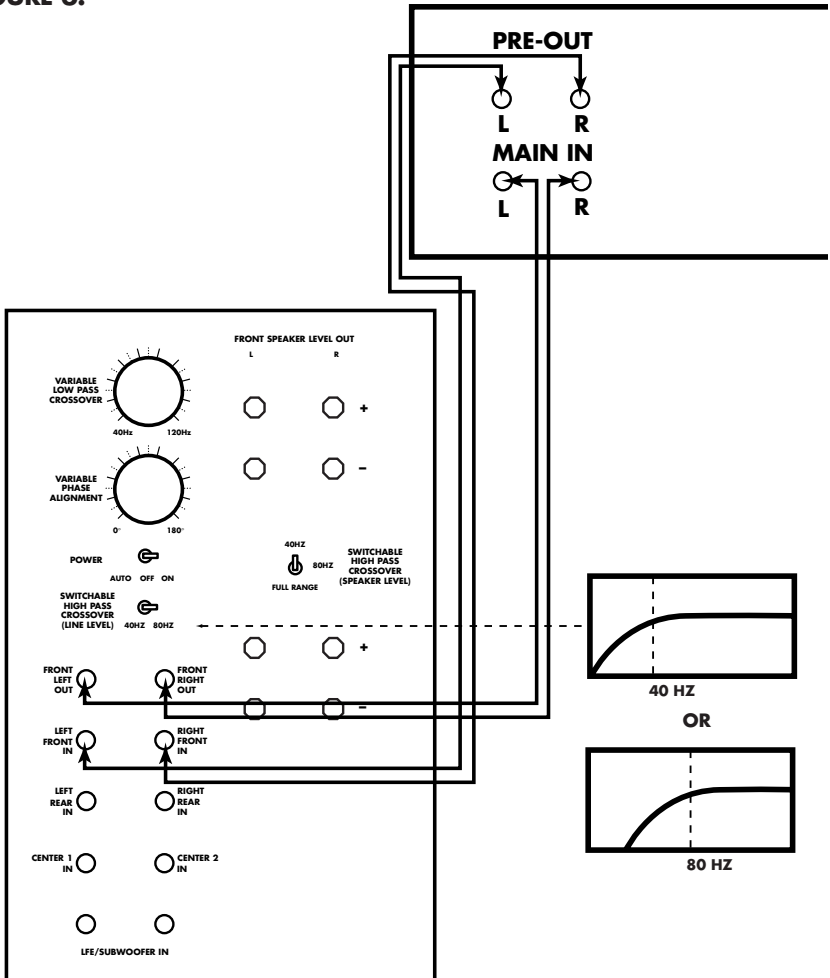

CENTER LINE IN—Connect Center line level preamp output here (**Fig. 7**). (There is no need to plug something into both center inputs; one would be redundant.) The signal will pass through the Variable Low Pass Crossover. Use a Y connector if you need to have this pre-out connected to a power amplifier or Main In jack. When this input senses a signal, it automatically boosts the Subwoofer's output

by 3dB. This feature is useful because most people like a little more bass for movies than music. When you are listening in stereo, the Center channel speaker is off so the boost does not “kick in.” As soon as you put on a movie in surround sound, the Center speaker turns on and the 3dB bass boost engages. If you do not want to use this feature, use an available input instead of one of these.

FIGURE 7. SURROUND RECEIVER OR PREAMP/PROCESSOR

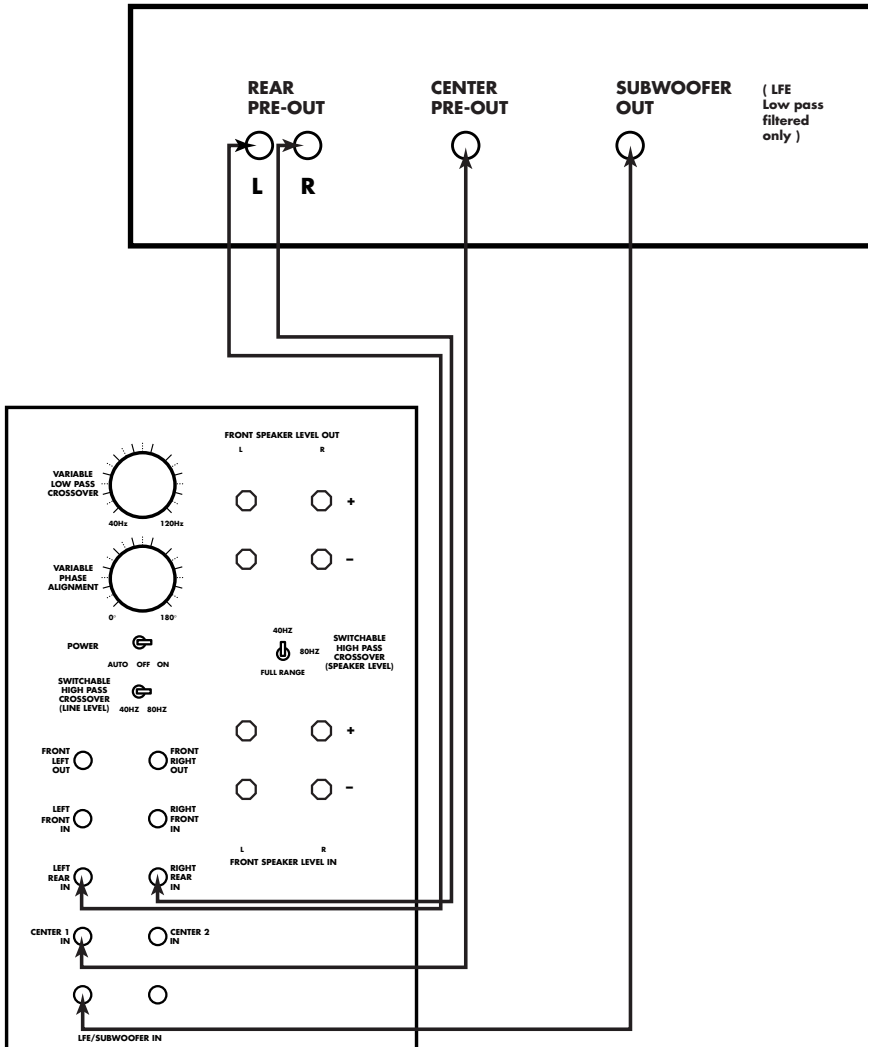
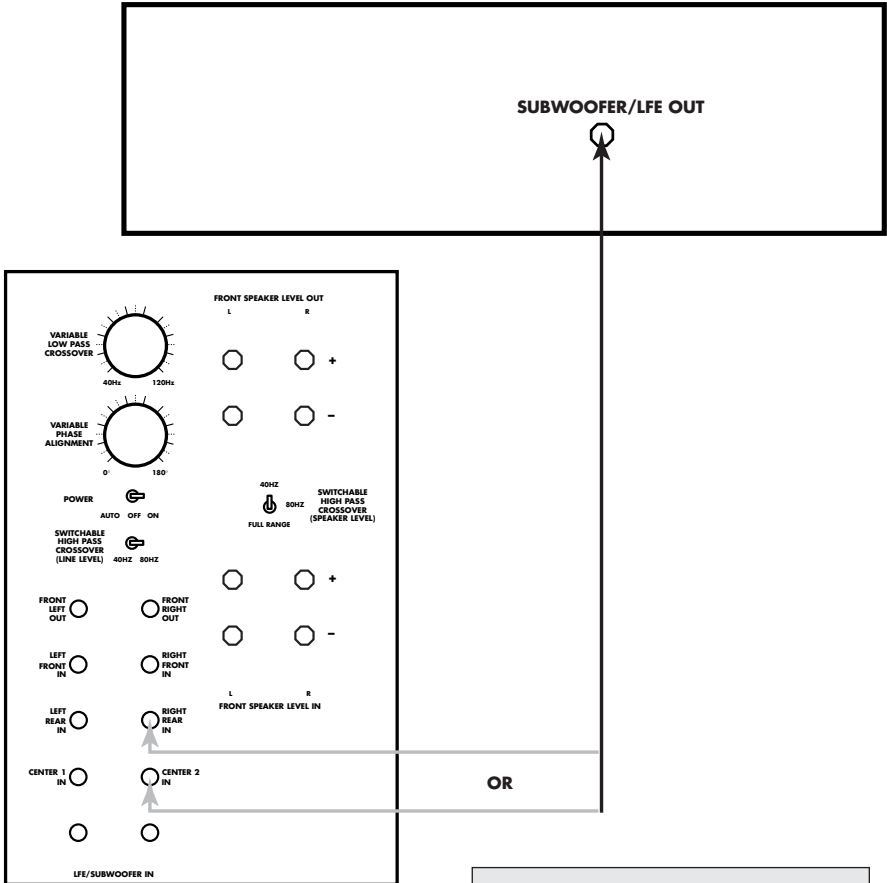

FIGURE 8. SURROUND RECEIVER OR PREAMP/PROCESSOR



LFE/SUBWOOFER IN - Use this input only if you have a Dolby Digital system and know your Subwoofer output jack is low pass filtered (Fig. 7 previous page). If the Subwoofer output jack is unfiltered, connect the subwoofer output jack to any unused Line Level In jack (Fig. 8). In either case, with Dolby Digital systems, select Subwoofer as "on" or "yes" in the "speaker set-up" or "bass management" function of your electronics. Read the owner's manual of your electronics to learn how to select

HOW TO TELL IF YOUR SUBWOOFER OUTPUT JACK IS FILTERED OR NOT
Use the "speaker set-up" or "bass management" function of your Dolby Digital processor to select Subwoofer as "on" or "yes." Connect the Subwoofer output jack to the "LFE/Subwoofer" input of the PSW1200. Disconnect the other speakers in the system so that all you can hear is the Subwoofer. Play music or a movie with vocal content. If you can hear and understand the words, your output jack is *not filtered*. If all you can hear is bass, and the vocals are barely or not at all audible, your Subwoofer input jack is *filtered*.

this setting.

polkaudio
The Speaker Specialists®

**5601 METRO DRIVE,
BALTIMORE, MARYLAND 21215, USA,
410-764-5275, FAX: 410-764-5266
<http://www.polkaudio.com>**



RM1203-1

Free Manuals Download Website

<http://myh66.com>

<http://usermanuals.us>

<http://www.somanuals.com>

<http://www.4manuals.cc>

<http://www.manual-lib.com>

<http://www.404manual.com>

<http://www.luxmanual.com>

<http://aubethermostatmanual.com>

Golf course search by state

<http://golfingnear.com>

Email search by domain

<http://emailbydomain.com>

Auto manuals search

<http://auto.somanuals.com>

TV manuals search

<http://tv.somanuals.com>