

Instruction manual

MODEL
CPL55GH8W

Oillube Compressor

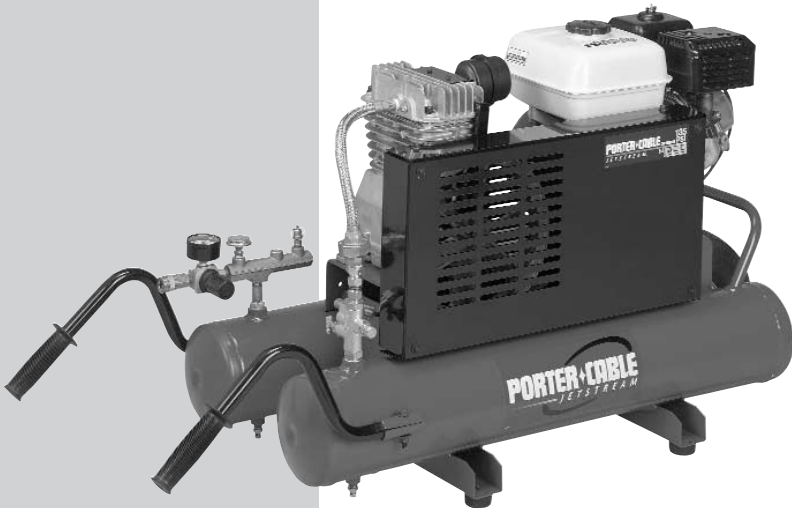

To learn more about Porter-Cable
visit our website at:
<http://www.porter-cable.com>

PORTER-CABLE
PROFESSIONAL POWER TOOLS

IMPORTANT

Please make certain that the person who is to use this equipment carefully reads and understands these instructions before starting operations.

The Model and Serial No. plate is located on the frame. Record these numbers in the spaces below and retain for future reference.

Model No. _____

Type _____

Serial No. _____

SAFETY GUIDELINES - DEFINITIONS

This manual contains information that is important for you to know and understand. This information relates to protecting **YOUR SAFETY** and **PREVENTING EQUIPMENT PROBLEMS**. To help you recognize this information, we use the symbols below. Please read the manual and pay attention to these symbols.

<p>⚠ DANGER Indicates an imminently hazardous situation which, if not avoided, will result in death or serious injury.</p>	<p>⚠ CAUTION Indicates a potentially hazardous situation which, if not avoided, may result in minor or moderate injury.</p>
<p>⚠ WARNING Indicates a potentially hazardous situation which, if not avoided, could result in death or serious injury.</p>	<p>CAUTION Used without the safety alert symbol indicates a potentially hazardous situation which, if not avoided, may result in property damage.</p>

IMPORTANT SAFETY INSTRUCTIONS

⚠ WARNING Some dust created by power sanding, sawing, grinding, drilling, and other construction activities contains chemicals known (to the State of California) to cause cancer, birth defects or other reproductive harm. Some example of these chemicals are:

- lead from lead-based paints
- crystalline silica from bricks and cement and other masonry products
- arsenic and chromium from chemically-treated lumber

Your risk from these exposures varies, depending on how often you do this type of work. To reduce your exposure to these chemicals: work in a well ventilated area, and work with approved safety equipment, always wear **MSHA/NIOSH** approved, properly fitting face mask or respirator when using such tools.

When using air tools, basic safety precautions should always be followed to reduce the risk of of personal injury.

⚠ WARNING This product is not equipped with a spark arresting muffler. If the product will be used around flammable materials, or on land covered with materials such as agricultural crops, forest, brush, grass, or other similar items, then an approved spark arrester must be installed and is legally required in the state of California. It is a violation of California statutes section 130050 and/or sections 4442 and 4443 of the California Public Resources Code, unless the engine is equipped with a spark arrester, as defined in section 4442, and maintained in effective working order. Spark arresters are also required on some U. S. Forest service land and may also be legally required under other statutes and ordinances.

This product may contain chemicals known to the state of California to cause cancer, birth defects, or other reproductive harm. This warning is given in compliance with California Proposition 65, as detectable amounts of chemicals subject to proposition 65 may be contained in this product.

IMPORTANT SAFETY INSTRUCTIONS



Save these instructions



Improper operation or maintenance of this product could result in serious injury and property damage. Read and understand all warnings and operation instructions before using this equipment.

HAZARD

WARNING: Risk of explosion or fire



What Could Happen	How To Prevent It
<p>Gasoline and gasoline vapors can become ignited by coming into contact with hot components such as the muffler, from engine exhaust gases, or from an electrical spark.</p>	<p>Turn engine off and allow it to cool before adding fuel to the tank. Equip area of operation with a fire extinguisher certified to handle gasoline or fuel fires.</p>
<p>Combustible materials which come into contact with hot engine parts can become ignited.</p>	<p>Add fuel outdoors in a well ventilated area. Make sure there are no sources of ignition, such as cigarettes near refueling location.</p> <p>Operate compressor in a clean, dry, well ventilated area a minimum of forty-eight inches from any building, object or wall.</p> <p>Do not operate unit indoors or in any confined area.</p> <p>Operate compressor in an open area away from dry brush, weeds or other combustible materials.</p> <p>Store fuel in a secure location away from compressor.</p>
<p>Unattended operation of this product could result in personal injury or property damage. To reduce the risk of fire, do not allow the compressor to operate unattended.</p>	<p>Always remain in attendance with the product when it is operating.</p>

HAZARD

WARNING: Risk of Bursting



Air Tank: The following conditions could lead to a weakening of the tank, and result in a violent tank explosion and could cause property damage or serious injury.

What Could Happen	How To Prevent It
1. Failure to properly drain condensed water from tank , causing rust and thinning of the steel tank.	Drain tank daily or after each use. If tank develops a leak, replace it immediately with a new tank or replace the entire compressor.
2. Modifications or attempted repairs to the tank.	Never drill into, weld, or make any modifications to the tank or its attachments. Never attempt to repair a damaged or leaking tank. Replace with a new tank.
3. Unauthorized modifications to the unloader valve, safety valve, or any other components which control tank pressure.	The tank is designed to withstand specific operating pressures. Never make adjustments or parts substitutions to alter the factory set operating pressures.
4. Excessive vibration can weaken the air tank and cause rupture or explosion. Excessive vibration will occur if the compressor is not properly mounted or if engine operates above recommended RPM.	Do not remove the stiffener bar connecting the compressor pump to the engine, except to adjust belt tension, Then securely tighten the stiffener bar nuts. This bar controls unit vibration.
<u>ATTACHMENTS & ACCESSORIES:</u> Exceeding the pressure rating of air tools, spray guns, air operated accessories, tires, and other inflatables can cause them to explode or fly apart, and could result in serious injury.	For essential control of air pressure, you must install a pressure regulator and pressure gauge to the air outlet (if not equipped) of your compressor. Follow the equipment manufacturers recommendation and never exceed the maximum allowable pressure rating of attachments. Never use compressor to inflate small low pressure objects such as children's toys, footballs, basketballs, etc.

HAZARD

WARNING: Risk from Flying Objects



WHAT CAN HAPPEN	HOW TO PREVENT IT
<p>The compressed air stream can cause soft tissue damage to exposed skin and can propel dirt, chips, loose particles, and small objects at high speed, resulting in property damage or personal injury.</p>	<p>Always wear ANSI Z87.1 approved safety glasses with side shields when using the compressor.</p> <p>Never point any nozzle or sprayer toward any part of the body or at other people or animals.</p> <p>Always turn the compressor off and bleed pressure from the air hose and tank before attempting maintenance, attaching tools or accessories.</p>

HAZARD

WARNING: Risk to Breathing



WHAT CAN HAPPEN	HOW TO PREVENT IT
<p>Breathing exhaust fumes from engines will cause serious injury or death.</p>	<p>Always operate air compressor outside in a clean, well ventilated area. Avoid enclosed areas such as garages, basements, storage sheds, which lack a steady exchange of air. Keep children, pets and others away from area of operation.</p>
<p>The compressed air directly from your compressor is not safe for breathing. The air stream may contain carbon monoxide, toxic vapors, or solid particles from the tank. Breathing these contaminants can cause serious injury or death.</p>	<p>Air obtained directly from the compressor should never be used to supply air for human consumption. In order to use air produced by this compressor for breathing, suitable filters and in-line safety equipment must be properly installed. In-line filters and safety equipment used in conjunction with the compressor must be capable of treating air to all applicable local and federal codes prior to human consumption.</p>
<p>Sprayed materials such as paint, paint solvents, paint remover, insecticides, weed killers, may contain harmful vapors and poisons.</p>	<p>Work in an area with good cross ventilation. Read and follow the safety instructions provided on the label or safety data sheets for the materials you are spraying. Use a NIOSH/ MSHA approved respirator designed for use with your specific application.</p>

HAZARD

WARNING: Risk of Burns



WHAT CAN HAPPEN	HOW TO PREVENT IT
<p>Touching exposed metal such as the compressor head, engine head, exhaust or outlet tubes, can result in serious burns.</p>	<p>Never touch any exposed metal parts on compressor during or immediately after operation. Compressor will remain hot for several minutes after operation. Do not reach around protective shrouds or attempt maintenance until unit has been allowed to cool.</p>

HAZARD

WARNING: Risk from Moving Parts



WHAT CAN HAPPEN	HOW TO PREVENT IT
<p>The engine can start accidentally if the flywheel is turned by hand or moved by pulling on the starter rope.</p>	<p>Always disconnect the spark plug and bleed pressure from the tank before performing maintenance.</p>
<p>Moving parts such as the pulley, flywheel, and belt can cause serious injury if they come into contact with you or your clothing.</p>	<p>Never operate the compressor with guards or covers which are damaged or removed.</p>
<p>Attempting to operate compressor with damaged or missing parts or attempting to repair compressor with protective shrouds removed can expose you to moving parts and can result in serious injury.</p>	<p>Any repairs required on this product should be performed by authorized service center personnel.</p>

HAZARD

WARNING: Risking of Falling



WHAT CAN HAPPEN	HOW TO PREVENT IT
<p>A portable compressor can fall from a table, workbench or proof causing damage to the compressor and could result in serious injury or death to the operator.</p>	<p>Always operate compressor in a stable secure position to prevent accidental movement of the unit. Never operate compressor on a roof or other elevated position. Use additional air hose to reach high locations.</p>

HAZARD

WARNING: Risk of Serious Injury or Property Damage when Transporting Compressor



(Fire, Inhalation, Damage to Vehicle Surfaces)

WHAT CAN HAPPEN	HOW TO PREVENT IT
<p>Oil can leak or spill and could result in fire or breathing hazard; serious injury or death can result. Oil leaks will damage carpet, paint or other surfaces in vehicles or trailers.</p>	<p>Always place compressor on a protective mat when transporting to protect against damage to vehicle from leaks. Remove compressor from vehicle immediately upon arrival at your destination. Never lie compressor on its side.</p>

HAZARD

WARNING: Risk of Unsafe Operation



WHAT CAN HAPPEN	HOW TO PREVENT IT
<p>Unsafe operation of your air compressor could lead to serious injury or death to you or others.</p>	<p>Review and understand all instructions and warnings in this manual.</p> <p>Become familiar with the operation and controls of the air compressor.</p> <p>Keep operating area clear of all persons, pets, and obstacles.</p> <p>Keep children away from the air compressor at all times.</p> <p>Do not operate the product when fatigued or under the influence of alcohol or drugs. Stay alert at all times.</p> <p>Never defeat the safety features of this product.</p> <p>Equip area of operation with a fire extinguisher.</p> <p>Do not operate machine with missing, broken, or unauthorized parts.</p>

SPECIFICATIONS

Model No.	CPL55GH8W
Engine Horsepower	5.5
Bore	2.875"
Stroke	2.0"
Air Tank Capacity (Gallon)	8
Approximate Unloader Reset Pressure	110 PSIG
Approximate Unloader Blow-off Pressure	135 PSIG
SCFM @ 40 PSIG	12.0
SCFM @ 90 PSIG	10.1

IMPORTANT: See engine operator's manual for engine information.

GLOSSARY

Become familiar with these terms before operating the unit.

CFM: Cubic feet per minute.

SCFM: Standard cubic feet per minute; a unit of measure of air delivery.

PSIG: Pounds per square inch gauge; a unit of measure of pressure.

Code Certification: Products that bear one or more of the following marks: UL, CUL, ETL, CETL, have been evaluated by OSHA certified independent safety laboratories and meet the applicable Underwriters Laboratories Standards for Safety.

California Code: Unit may comply with California Code 462 (I) (2)/(M) (2). Specification/model label is on the side of the tank on units that comply with California Code.

Unloader Blow-Off Pressure: All models are continuous running units controlled by tank pressure. When the maximum tank pressure is obtained, the unloader valve will blow-off. This will cause the compressor to exhaust the air to the atmosphere and not the tank. This decreases the load on the engine and allows it to run at a near no-load condition.

Unloader Reset Pressure: When the tank pressure drops to a predetermined point, the unloader valve closes. The tank pressure will now increase until it reaches the unloader blow-off pressure.

ACCESSORIES

Accessories for this unit are available at the store the unit was purchased.

ASSEMBLY

Unpacking

1. Remove unit from carton and discard all packaging. **NOTE:** Save all parts bags.

CAUTION The wheels and handle do not provide adequate clearance, stability or support for pulling the unit up and down stairs or steps. The unit must be lifted, or pushed up a ramp.

Installing Handle

CAUTION Do not use the engine gas tank as a support for lifting the air compressor.

1. Push rubber handle grips (L), onto handle tubes (M). Seat firmly. Use a twisting motion to ease assembly. See Figure.

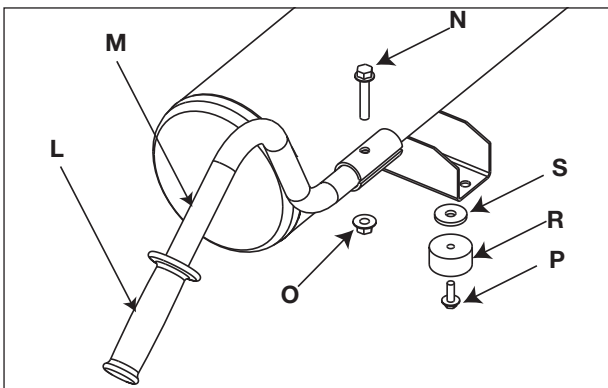

2. Position one handle and grip assembly into clamp on left side of tank assembly, as shown in Figure. Align hole in handle with hole in clamp. Insert bolt (N) through the hole (in clamp and handle). Thread nut (O) onto bolt. Using two 1/2" wrenches (not furnished) tighten nut securely.
3. Repeat step 2 to assemble remaining handle and grip assembly to the clamp on the right side of tank assembly.
4. Using a 9/16" socket wrench (not furnished) remove the four bolts securing the compressor to the shipping skid.
 - A. Place spacer (S) on flat side of a rubber foot (R). Place spacer and rubber foot against compressor frame as shown in Figure.
 - B. Align hole in spacer and rubber foot with one of the smaller holes adjacent to the holes where shipping skid was attached.
 - C. Insert one of the 1/4"-20 x 3/4" bolts (P), from the hardware package, and using a 3/8" socket wrench (not furnished) tighten firmly.
 - D. Repeat A through C to install the three remaining rubber feet.

Lubrication and Oil

Engine

⚠ WARNING Drain tank to release air pressure before removing the oil fill cap or oil drain plug.

1. The engine was filled **WITH** oil at the manufacturer. Check engine oil level before operating unit. If necessary, fill engine to the appropriate level with recommended oil, see engine manual supplied by engine manufacturer for correct procedure.
2. Add fuel to engine. See engine manual supplied by engine manufacturer for correct procedure.

⚠ WARNING Gasoline vapor is highly flammable. Refuel outdoors preferably, or only in well-ventilated areas. Do not refuel or check gasoline level while the engine is running. Do not store, spill, or use gasoline near an open flame, a source of sparks (such as welding), or near operating electrical equipment.

Air Compressor

The air compressor pump was filled **WITH** oil at the manufacturer. Check air compressor pump oil level before operating unit. If necessary, fill pump to the appropriate level with approved compressor oil, see the Maintenance section of this manual for details.

INSTALLATION

Location of the Air Compressor

⚠ WARNING Exhaust from the gasoline engine contains deadly carbon monoxide, which is odorless and toxic. Operate engine only in well ventilated areas.

The air compressor must be operated in a clean, dry, and well-ventilated area. The air compressor's crankcase and head are designed with cooling fins to provide proper cooling. The fan blades of the compressor, the flywheel, must be kept clear of obstructions that could interfere with the flow of air through the air intake filter.

Do not install the air compressor in a location where heat is excessive. If the humidity in the operating area is high, an air filter can be installed on the air outlet adapter to remove excessive moisture. This type air filter is not provided with this air compressor and must be purchased separately. Closely follow the instructions packaged with the filter for proper installation.

⚠ CAUTION Do not allow the air compressor to get wet if it is installed outdoors.

Piping

⚠ WARNING Plastic or PVC pipe is not designed for use with compressed air. Regardless of its indicated pressure rating, plastic pipe can burst from air pressure. use only metal pipe for air distribution.

If a pipe line is necessary, use pipe that is the same size as the air tank outlet. Piping that is too small will restrict the flow of air. If piping is over 100 feet long, use the next larger size. Bury underground lines below the frost line and avoid pockets where condensation can gather and freeze. Apply pressure to lines before underground lines are buried to make sure all pipe joints are free of leaks.

OPERATION

Know Your Air Compressor

READ THIS OWNER'S MANUAL AND SAFETY RULES BEFORE OPERATING YOUR UNIT. Compare the illustrations with your unit to familiarize yourself with the location of various controls and adjustments. Save this manual for future reference.

Description of Operation

Become familiar with these controls before operating the unit.

Air Compressor Pump (not shown): Compresses air into the air tank.

Unloader Valve (not shown): When the maximum tank pressure is obtained, the unloader valve will exhaust the compressed air to the atmosphere (blow-off). When the tank pressure drops to a pre-determined point, the unloader valve closes and causes the tank pressure to increase.

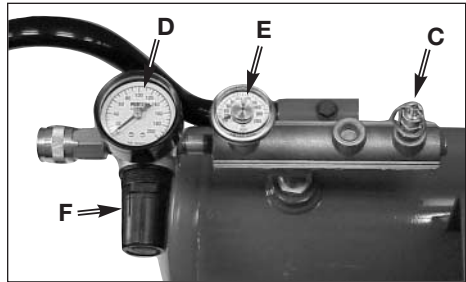

Safety Valve (C): If the unloader valve does not release pressure when tank reaches "blow-off" pressure, the safety valve will protect against high pressure by "popping off" at its factory set pressure (slightly higher than the pressure switch blow-off setting).

Outlet Pressure Gauge (D): The outlet pressure gauge indicates the air pressure available at the outlet side of the regulator. This pressure is controlled by the regulator and is always less than or equal to the tank pressure.

Tank Pressure Gauge (E): The tank pressure gauge indicates the reserve air pressure in the tank.

Regulator (F): Controls the air pressure shown on the outlet pressure gauge. Pull the knob out and turn clockwise to increase pressure and counterclockwise to decrease pressure. When the desired pressure is reached push knob in to lock in place.

Drain Valve (not shown): A drain valve is located at the base of each air tank and is used to drain condensation at the end of each use.

Air Intake Filter (not shown): This filter is designed to clean air coming into the pump. This filter **must** always be clean and ventilation openings free from obstructions. See "Maintenance".

Throttle Control (not shown): A throttle control has been incorporated as an extra feature. When maximum tank pressure is reached and the unloader valve vents air, it also activates a throttle control on the engine. This gas saving feature holds the engine at a factory-set idling speed until air pressure in the air tank drops to reset pressure. It then reactivates the throttle control and accelerates the engine to full throttle.

How to Use Your Unit

How to Stop:

1. See the engine manufacturer's manual for the procedure to safely shut down the gasoline engine. Turning the gasoline engine off will turn off the air compressor as well.

Before First Start-up

Break-in Procedure

⚠ WARNING Serious damage may result if the following break-in instructions are not closely followed.

This procedure is required when:

1. Before the air compressor is used for the first time.
2. When the unloader valve is replaced.
3. When a complete compressor pump is replaced.

The procedure:

1. To prevent pressure from building up in the air tanks during this break-in period, you must open the unit's unloader valve. Place unloader valve in "Open" position as shown.
2. Open the pressure regulator. Pull regulator knob and rotate clockwise until it stops.
3. Start engine. See engine manual supplied by engine manufacturer for correct procedure.

⚠ CAUTION The air compressor is top heavy. Make sure the unit is in a stable position and will not tip before pulling the starter cord of the engine.

4. Make sure the unloader valve is in the "Open" position to prevent tank pressure buildup.
5. Run the air compressor for **30 minutes** to seat the rings and lubricate all the internal surfaces. Make sure there is no pressure build up in the tank by observing the reading on the tank pressure gauge.
6. Place unloader valve in the "Closed" position as shown.
7. Close the pressure regulator. Rotate the regulator knob counter-clockwise to its built-in stop and push knob in to lock in place. This will allow air to build pressure in the air tanks.

NOTE: When the air tank is pressurized, the tank pressure gauge will indicate the pressure available in the air tank and the gasoline engine will reduce its speed to idle and keep running. The pressurization of the air tank will be adjusted automatically by the "reset" and "blow off" setting of the unloader valve. When the pressure in the air tank drops to the "reset" value, the gasoline engine will increase its rpm to operate the compressor and pressurize the tanks. When the pressure in the air tank increases to the "blow off" value, the engine rpm will drop to idle.

NOTE: Consult the engine manufacturer's manual for the proper engine break-in running time and oil change interval for the engine used on your air compressor as well as other engine maintenance requirements.

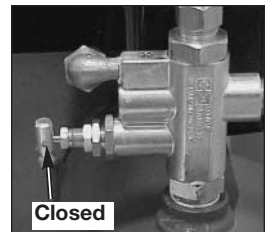
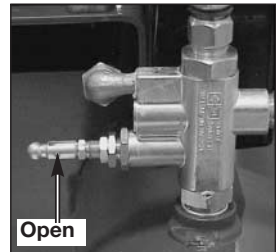

- Compressed air will be available from the unit's outlet valve until it is used up or bled off. The compressor is now ready for use.

Before each start-up

Perform the following checks before starting the air compressor.

- Make sure nothing is blocking the belt guard, air openings, or air filter inlet.
- Make sure the unloader valve moves freely and smoothly.
- Check the oil level in the pump and engine, add oil if necessary.

⚠ WARNING Temperature of muffler and near by areas may exceed 150°F (65°C) avoid these areas.

- Clean or blow off fins or any part of the air compressor that collects dust and dirt. The air compressor will run cooler and provide longer service.
- Open the unloader valve of the air compressor before starting the engine.

To start-up

- Start the engine (see engine manual supplied by engine manufacturer for correct procedure) and close unloader to allow tank pressure to pump up to blow-off pressure.

⚠ CAUTION Unit is top heavy. Make sure the compressor is stable and will not tip before pulling the starting cord.

⚠ WARNING Too much air pressure causes a hazardous risk of bursting. Closely monitor the air pressure gauge of the tank so the maximum pressure limit is not exceeded and monitor the safety valve to ensure excess pressure is discharged. If pressure continues to build beyond safe limits, shut the unit down immediately and troubleshoot the problem.

- Check all fittings and piping for air leaks. Even minor leaks can cause the air compressor to overwork, resulting in premature breakdown or unsatisfactory performance.
- Check for any unusual vibration and noise.
- Check for oil leaks and correct any leaks found.
- Check the pressure ratings of the air tools and accessories being used with this air compressor before attaching, then adjust the shut-off valve for that value.

⚠ WARNING The air compressor's outlet pressure must never exceed the maximum pressure rating of the tool or accessory being used. If a pressure regulator is not used, do not use accessories rated at less than 110 psi.

- Attach air hose and accessory. Your unit is ready for use.

⚠ CAUTION Compressed air from the unit may contain water condensation and oil mist. Do not spray unfiltered air at an item that could be damaged by moisture. Some air operated tools or devices may require filtered air. Read the instructions for the air tool or device.

Shutting Down

- Turn off engine.
- Close the pressure regulator.
- Remove the air tool or accessory.
- Open pressure regulator and allow air to slowly bleed from the tank. Close the regulator when the tank pressure is approximately 20 PSIG.

⚠ WARNING

Drain air tank daily. Water will condense in air tank. If not drained, water will corrode and weaken the air tank causing a risk of tank rupture.

16. With tank pressure at approximately 20 PSIG, open the drain valves and allow moisture to drain.

NOTE: If drain cock is clogged, release all air pressure. The drain cock can then be removed, cleaned, and reinstalled.

17. After the water has been drained, close the drain cocks. The air compressor can now be stored.

MAINTENANCE

Customer Responsibilities

	Before each use	Daily or after each use	Every 8 hours	Every 40 hours	Every 100 hours	Every 160 hours	Yearly
Check Safety Valve	●						
Drain Tank		●					
Oil Leaks			●				
Check Pump Oil			●				
Change Pump Oil					● ¹		
Unusual Noise and/or Vibration			●				
Air Filter				● ¹			
Drive Belt -Condition				●			
Motor Pulley/Flywheel alignment						●	
Inspect air lines and fittings for leaks						●	
Air compressor pump intake and exhaust valves							●

1- more frequent in dusty or humid conditions

Consult the Engine Owners Manual for the manufacturer's recommendations for any and all engine maintenance.

▲WARNING During maintenance, you could be exposed to compressed air or moving parts. Personal injuries can occur. Before doing any maintenance or repair, disconnect the spark plug wire to prevent accidental starting, and relieve air tank pressure. Never operate the compressor with the belt guard removed.

To ensure efficient operation and longer life of the air compressor outfit, a routine maintenance schedule should be prepared and followed. The following routine maintenance schedule is geared to an outfit in a normal working environment operating on a daily basis. If necessary, the schedule should be modified to suit the conditions under which your compressor is used. The modifications will depend upon the hours of operation and the working environment. Compressor units in an extremely dirty and/or hostile environment will require a greater frequency of all maintenance checks.

NOTE: See "Operation" section for the location of controls.

To Check Safety Valve

▲WARNING If the safety valve does not work properly, over-pressurization may occur, causing air tank rupture or an explosion.

1. Before starting compressor, pull the ring on the safety valve to make sure that the safety valve operates freely. If the valve is stuck or does not operate smoothly, it must be replaced with the same type of valve.

To Drain Tank

1. Turn off engine.
2. Remove the air tool or accessory.
3. Pull ring on safety valve allowing air to bleed from the tank until tank pressure is approximately 20 psi. Release safety valve ring.
4. Drain water from air tank by opening drain valve (counter-clockwise) on bottom of tank.

⚠ WARNING Water will condense in the air tank. If not drained, water will corrode and weaken the air tank causing a risk of air tank rupture.

5. After the water has been drained, close the drain valve (clockwise). The air compressor can now be stored.

NOTE: If drain valve is plugged, release all air pressure. The valve can then be removed, cleaned, then reinstalled.

Oil

⚠ WARNING Drain tank to release air pressure before removing the oil fill cap or oil drain plug.

Checking

1. Remove the oil fill plug (A). The oil level should be even with the top of the fill hole and no lower than 6 threads from the top of fill hole.
2. If needed, slowly add oil until it reaches the top of fill hole.

NOTE: Use an oil specifically formulated for use in an air compressor, such as Sears 9-16426 air compressor oil.

Changing

1. Remove the oil fill plug (A).
2. Remove the oil drain plug (B) and drain oil into a suitable container.
3. Replace the oil drain plug (B) and tighten securely
4. Slowly fill crankcase to the top of the fill hole. Crankcase capacity is 16 fluid ounces (473.2 ml).

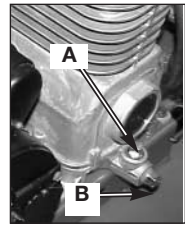

⚠ CAUTION Overfilling with oil will cause premature compressor failure. Do not overfill.

5. Replace oil fill plug (A) and tighten securely.

Air Filter - Inspection and Replacement

⚠ WARNING Hot surfaces. Risk of burn. Compressor heads are exposed when filter cover is removed. Allow compressor to cool prior to servicing.

⚠ CAUTION Keep the air filter clean at all times. Do not operate the air compressor with the air filter removed.

A dirty air filter will not allow the compressor pump to operate at full capacity. Before using the compressor pump, check the air filter to make sure it is clean and in place.

If it is dirty, replace it with a new filter.

1. Remove the air filter cover.
2. Remove the air filter from filter cover.



IMPORTANT: Do not operate the compressor with the air filter removed.

3. Place new air filter into filter cover. Refer to the "Repair Parts" for the correct part number.
4. Replace air filter cover and lock into place.

Air Compressor Pump Intake and Exhaust Valves

Once a year have a Trained Service Technician check the air compressor pump intake and exhaust valves.

SERVICE AND ADJUSTMENTS

ALL MAINTENANCE AND REPAIR OPERATIONS NOT LISTED MUST BE PERFORMED BY TRAINED SERVICE TECHNICIAN.

⚠ WARNING

Before servicing:

- Stop engine.
- Bleed tank of pressure.
- Allow the air compressor to cool.

Safety Valve-Inspection and Replacement

⚠ WARNING

If the safety valve does not work properly, over-pressurization can occur and cause air tank rupture or explosion.

Daily pull the ring on the safety valve and make sure it operates freely. If the valve is stuck or does not operate smoothly, it must be replaced with the same type of valve having an identical pressure rating.

To Remove Safety Valve:

1. Make sure the air compressor unit is off and disconnect the spark plug wire.
2. Open the outlet valve and allow all air to bleed from the tank. Monitor tank pressure gauge as tank is emptied.
3. When tank is empty, remove safety valve (A) from manifold. Refer to Figure.



To Install New Safety Valve:

1. Verify new safety valve is the correct pressure rating for your air compressor.
2. Verify threads for safety valve in manifold are clean.
3. Apply thread sealant to the threads of new safety valve.
4. Install new valve and hand-tighten.
5. Tighten nut to secure safety valve to manifold. **Do not overtighten.**
6. Reconnect spark plug wire to engine.
7. Perform the **Daily Start Up Checklist**.

Belt – Replacement and Adjustment

▲ WARNING Serious injury or damage may occur if parts of the body or loose items get caught in moving parts. Never operate the unit with the belt guard removed. The belt guard should be removed only when the air compressor is turned off the spark plug wire is disconnected.

Belt Guard – Removal

1. Disconnect the spark plug wire on the engine and release all air tank pressure.
2. Remove the six screws (A) from the belt guard. The front of the belt guard can now be removed.

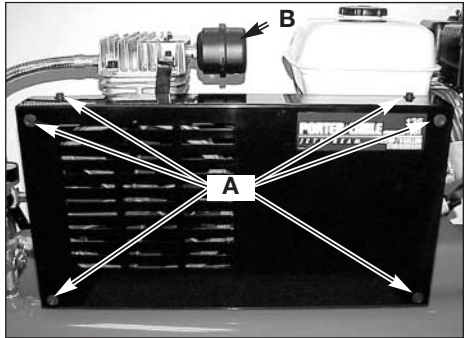

Belt – Replacement

1. Disconnect the spark plug wire on the engine and release all air tank pressure.
2. Remove the front of the belt guard as previously described.
3. Mark engine position on saddle.
4. Loosen stiffener bracket screw on engine.
5. Being careful not to remove the stiffener plate under the saddle, loosen the six engine mounting bolts (C).
6. Slide engine toward pump to remove tension from the belt, and then remove the old belt.
7. Install the new belt over the pulleys.

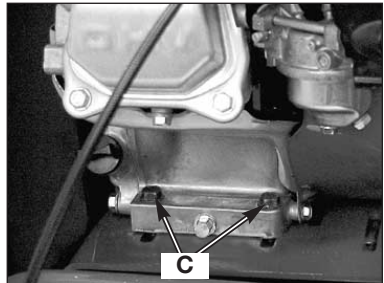

NOTE: The belt must be centered over the grooves on the engine pulley and flywheel.

8. Slide the engine back into its regular position. Line the engine up with the mark made earlier on saddle.

Belt Tension - Adjustment

1. Slide the engine back into its regular position. Line the engine up with the mark made earlier on saddle.
2. Hold belt tension and securely tighten two engine mounting bolts.
3. Measure correct belt tension. Proper tension is achieved when a three (3) pound weight or equivalent finger pressure applied midway between the motor pulley and compressor flywheel causes a 1/4" deflection of the belt. Refer to Figure 10.

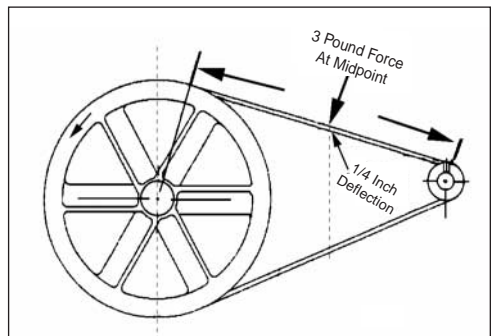

- When proper belt tension is achieved, tighten the remaining engine mounting bolts.
- Tighten stiffener bracket screw.

NOTE: Once the engine pulley has been moved from its factory set location, the grooves of the flywheel and pulley must be aligned to within 1/16" to prevent excessive belt wear. Verify the alignment by performing the following Pulley and Flywheel - Alignment.

Pulley and Flywheel - Alignment

The air compressor flywheel and engine pulley must be in-line (in the same plane) within 1/16" to assure belt retention within flywheel belt grooves. To check alignment, perform the following steps:

- Disconnect the spark plug wire on the engine and release all air tank pressure.

- Remove belt guard.

- Place a straightedge against the outside of the flywheel and the engine drive pulley.

- Measure the distance between the edge of the belt and the straightedge at points A1 and A2 in Figure.

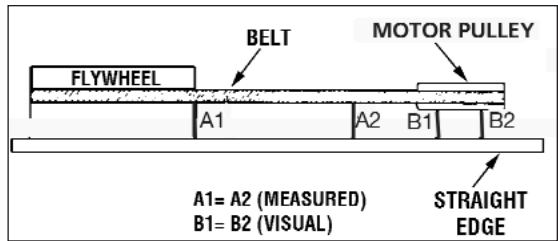

The difference between measurements should be no more than 1/16".

- If the difference is greater or less than 1/16", loosen the setscrew holding the engine drive pulley to the shaft and adjust the pulley's position on the shaft until the A1 and A2 measurements are within 1/16" of each other.
- Tighten the engine drive pulley setscrew to 70-80 in.-lbs.
- Visually inspect the engine drive pulley to verify that it is perpendicular to the drive motor shaft. Points B1 and B2 of Figure should appear to be equal. If they are not, loosen the setscrew of the engine drive pulley and equalize B1 and B2, using care not to disturb the belt alignment performed in step 2.
- Retighten the engine drive pulley setscrew to 70-80 in.-lbs.
- Reinstall belt guard.
- Reconnect spark plug wire to spark plug on engine.

STORAGE

Before you store the air compressor, make sure you do the following:

1. Review the "Maintenance" section on the preceding pages and perform scheduled maintenance as necessary.
2. Review the "Engine Manufacturer's Operating and Maintenance Instructions".
3. Remove the air tool or accessory.
4. Pull ring on safety valve allowing air to bleed from the tank until tank pressure is approximately 20 psi. Release safety valve ring.
5. Drain water from air tank by opening drain valve on bottom of tank.

⚠ WARNING Water will condense in the air tank. If not drained, water will corrode and weaken the air tank causing a risk of air tank rupture.

6. After the water has been drained, close the drain or drain valve.

NOTE: If drain valve is plugged, release all air pressure. The valve can then be removed, cleaned, then reinstalled.

7. Wind air hose around hose wrap and secure in place.
8. Store the air compressor in a clean and dry location.

TROUBLESHOOTING

⚠ WARNING Performing repairs may expose voltage sources, moving parts or compressed air sources, moving parts or compressed air sources. Personal injury may occur. Prior to attempting any repairs, unplug the air compressor and bleed off all air tank air pressure.

PROBLEM	CAUSE	CORRECTION
Excessive tank pressure-safety valve pops off.	Unloader valve does not release pressure when tank reaches "blow-off" pressure.	Unloader valve must be replaced.
Air leaks at fittings.	Tube fittings are not tight enough.	Tighten fittings where air can be heard escaping. Check fittings with soapy water solution. DO NOT OVER-TIGHTEN.
Continuous air leak at unloader valve.	Defective unloader valve.	Turn off engine, move unloader valve toggle lever to vertical position. If air leaks out of tank through unloader valve, clean or replace unloader valve.
Air leaks in air tank or at air tank welds.	Defective air tank.	Air tank must be replaced. Do not repair the leak. ⚠ WARNING Do not drill into, weld or otherwise modify air tank or it will weaken. The tank can rupture or explode.
Air leaks between head and valve plate.	Leaking seal.	Contact a Trained Service Technician.
Air leaks from safety valve.	Possible defect in safety valve.	Operate safety valve manually by pulling on ring. If valve still leaks, it should be replaced.

PROBLEM	CAUSE	CORRECTION
Compressor is not supplying enough air to operate accessories.	<p>Prolonged excessive use of air. Compressor is not large enough for air requirement.</p> <p>Hole in hose.</p> <p>Unloader valve restricted.</p> <p>Air leaks.</p> <p>Restricted air intake filter</p> <p>Loose belt.</p>	<p>Decrease amount of air usage.</p> <p>Check the accessory air requirement. If it is higher than the SCFM or pressure supplied by your air compressor, you need a larger compressor.</p> <p>Check and replace if required.</p> <p>Remove and clean, or replace.</p> <p>Tighten fittings.</p> <p>Clean or replace air intake filter. Do not operate the air compressor with the filter removed. Refer to the "Air Filter" paragraph in the "Maintenance " section.</p> <p>Check belt tension, see Adjusting Belt Tension in the Maintenance section.</p>
Restricted air intake.	Dirty air filter.	Clean or replace. See Air Filter paragraph in the Maintenance section.
Excessive vibration.	<p>Engine or pump mounting screws are loose.</p> <p>Stiffener bracket screw is loose.</p>	<p>⚠ WARNING Excessive vibration could weaken the air tank and cause it to rupture or explode. Stiffener bar nuts and mounting screws must be kept tightened. Never operate the unit unless equipped with the stiffener bar and rubber feet.</p>

PROBLEM	CAUSE	CORRECTION
Knocking Noise.	Possible defect in safety valve.	Operate safety valve manually by pulling on ring. If valve still leaks, it should be replaced.
	Loose pulley.	Tighten pulley set screw, see Parts manual for torque specifications.
	Loose flywheel.	Tighten flywheel screw, see Parts manual for torque specifications.
	Compressor or engine mounting screws loose.	Tighten mounting screws, see Parts manual for torque specifications.
	Loose belt.	Check belt tension, see Adjusting Belt Tension in the Maintenance section
	Carbon build-up in pump.	Have checked by a Trained Service Technician.
	Belt too tight.	Check belt tension, see Adjusting Belt Tension in the Maintenance section
	Stiffener bar loose.	Check both nuts and tighten if required.
	Low oil level (compressor or engine)	Maintain prescribed oil level. Add oil.
Excessive belt wear.	Loose belt.	Check belt tension, see Adjusting Belt Tension in the Maintenance section
	Tight belt.	Check belt tension, see Adjusting Belt Tension in the Maintenance section
	Loose pulley.	Have checked by a Trained Service Technician.
	Pulley misalignment.	See Motor Pulley/Flywheel Alignment paragraph in the Maintenance section.

PROBLEM	CAUSE	CORRECTION
Squealing sound.	Compressor pump has no oil. Loose belt.	See Oil-Checking paragraph in the Maintenance section. Check belt tension, see Adjusting Belt Tension in the Maintenance section
Engine will not run.	The gasoline tank is empty. The choke is not set properly. Air tank pressure is too high.	Fill the tank with gas. Re-set the choke. Remember, a warm engine requires less choking than a cold engine. Open the ball valve and reduce tank pressure to less than 40 psig.
Pressure reading on the regulated pressure gauge (if equipped) drops when an accessory is used.	It is normal for "some" pressure drop to occur.	If there is an excessive amount of pressure drop when the accessory is used, adjust the regulator as instructed in the Operation section. NOTE: Adjust the regulated pressure under flow conditions (while accessory is being used).
Regulator knob has continuous air leak.	Damaged regulator	Replace
Regulator will not shut off air outlet.	Damaged regulator	Replace

LIMITED WARRANTY

PORTER-CABLE CORPORATION warrants to the original purchaser that all products covered under this warranty are free from defects in material and workmanship. Products covered under this warranty include air compressors, air tools, service parts, pressure washers, and generators, which have the following warranty periods:

3 YEARS - Limited warranty on 2-stage oil-free air compressor pumps that operate at 1725 RPM.

2 YEARS - Limited warranty on oil-lubricated air compressor pumps.

1 YEAR - Limited warranty on all other air compressor components.

2 YEARS - Limited warranty on electric generator alternators.

1 YEAR - Limited warranty on other generator components.

2 YEARS - Limited warranty on pneumatic air tools as described in Porter-Cable general catalog.

1 YEAR - Limited warranty on pressure washers used in consumer applications (i.e. personal residential household usage only).

90 DAY - Pressure washers used for commercial applications (income producing) and service parts.

1 YEAR - Limited warranty on all accessories.

Porter-Cable will repair or replace, at **Porter-Cable's** option, products or components which have failed within the warranty period. Service will be scheduled according to the normal work flow and business hours at the service center location, and the availability of replacement parts. All decisions of **Porter-Cable Corporation** with regard to this limited warranty shall be final.

This warranty gives you specific legal rights, and you may also have other rights which vary from state to state.

RESPONSIBILITY OF ORIGINAL PURCHASER (initial User):

- To process a warranty claim on this product, DO NOT return it to the retailer. The product must be evaluated by a **Porter-Cable** Authorized Warranty Service Center. For the location of the nearest **Porter-Cable** Authorized Warranty Service Center call 1-888-559-8550, 24 hours a day, 7 days a week.
- Retain original cash register sales receipt as proof of purchase for warranty work.
- Use reasonable care in the operation and maintenance of the product as described in the Owners Manual(s).
- Deliver or ship the product to the nearest **Porter-Cable** Authorized Warranty Service Center. Freight costs, if any, must be paid by the purchaser.
- Air compressors with 60 and 80 gallon tanks will be inspected at the site of installation. Contact the nearest **Porter-Cable** Authorized Warranty Service Center that provides on-site service calls, for service call arrangements.
- If the purchaser does not receive satisfactory results from the **Porter-Cable** Authorized Warranty Service Center, the purchaser should contact Porter-Cable.

THIS WARRANTY DOES NOT COVER:

- Merchandise sold as reconditioned, used as rental equipment, and floor or display models.
- Merchandise that has become damaged or inoperative because of ordinary wear, misuse*, cold, heat, rain, excessive humidity, freeze damage, use of improper chemicals, negligence, accident, failure to operate the product in accordance with the instructions provided in the Owners Manual(s) supplied with the product, improper maintenance, the use of accessories or attachments not recommended by **Porter-Cable**, or unauthorized repair or alterations.
- * An air compressor that pumps air more than 50% during a one hour period is considered misuse because the air compressor is undersized for the required air demand.
- Repair and transportation costs of merchandise determined not to be defective.
- Costs associated with assembly, required oil, adjustments or other installation and start-up costs.
- Expendable parts or accessories supplied with the product which are expected to become inoperative or unuseable after a reasonable period of use, including but not limited to sanding disks or pads, saw and shear blades, grinding stones, springs, chisels, nozzles, o-rings, air jets, washers and similar accessories.
- Merchandise sold by **Porter-Cable** which has been manufactured by and identified as the product of another company, such as gasoline engines. The product manufacturer's warranty, if any, will apply.
- **ANY INCIDENTAL, INDIRECT OR CONSEQUENTIAL LOSS, DAMAGE, OR EXPENSE THAT MAY RESULT FROM ANY DEFECT, FAILURE OR MALFUNCTION OF THE PRODUCT IS NOT COVERED BY THIS WARRANTY.** Some states do not allow the exclusion or limitation of incidental or consequential damages, so the above limitation or exclusion may not apply to you.
- **IMPLIED WARRANTIES, INCLUDING THOSE OF MERCHANTABILITY OR FITNESS FOR A PARTICULAR PURPOSE, ARE LIMITED TO ONE YEAR FROM THE DATE OF ORIGINAL PURCHASE.** Some states do not allow limitations on how long an implied warranty lasts, so the above limitations may not apply to you.

PORTER-CABLE

Porter-Cable Corporation
Jackson, TN USA
1-888-559-8550

Free Manuals Download Website

<http://myh66.com>

<http://usermanuals.us>

<http://www.somanuals.com>

<http://www.4manuals.cc>

<http://www.manual-lib.com>

<http://www.404manual.com>

<http://www.luxmanual.com>

<http://aubethermostatmanual.com>

Golf course search by state

<http://golfingnear.com>

Email search by domain

<http://emailbydomain.com>

Auto manuals search

<http://auto.somanuals.com>

TV manuals search

<http://tv.somanuals.com>