

Instruction manual

Double Insulated Disc Sander/Grinder

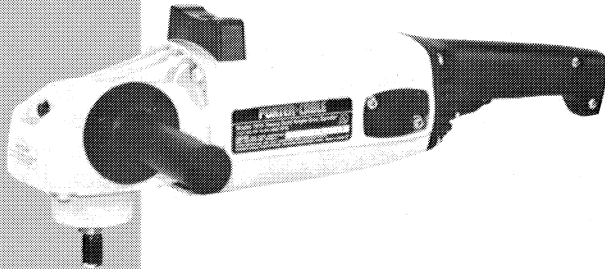

MODELS 7615, 7616, 87615, and 87616

IMPORTANT

Please make certain that the person who is to use this equipment carefully reads and understands these instructions before starting operations.

The Model and Serial No. plate is located on the main housing of the tool. Record these numbers in the spaces below and retain for future reference.

Model No. _____

Type _____

Serial No. _____

Part No. 691532-383

PORTER-CABLE
PROFESSIONAL POWER TOOLS

IMPORTANT SAFETY INSTRUCTIONS

WARNING: When using electric tools, basic safety precautions should always be followed to reduce the risk of fire, electric shock and personal injury, including the following:

READ AND FOLLOW ALL INSTRUCTIONS.

There are certain applications for which this tool was designed. Porter-Cable strongly recommends that this tool NOT be modified and/or used for any application other than for which it was designed. If you have any questions relative to its application DO NOT use the tool until you have written Porter-Cable and we have advised you.

Manager of Product Engineering
Porter-Cable Corporation
Youngs Crossing at Highway 45
P.O. Box 2468
Jackson, Tn 38301

- 1. KEEP WORK AREA CLEAN.** Cluttered areas and benches invite injuries.
- 2. AVOID DANGEROUS ENVIRONMENT.** Don't expose power tools to rain. Don't use power tools in damp or wet locations. Keep area well lit. Avoid chemical or corrosive environment. Do not use tool in presence of flammable liquids or gases.
- 3. GUARD AGAINST ELECTRIC SHOCK.** Prevent body contact with grounded surfaces. For example: pipes, radiators, ranges, refrigerator enclosures.
- 4. KEEP CHILDREN AWAY.** Do not let visitors contact tool or extension cord. All visitors should be kept away from work area.
- 5. STORE IDLE TOOLS.** When not in use, tools should be stored in dry and high or locked-up place — out of the reach of children.
- 6. DON'T FORCE TOOL.** It will do the job better and safer at the rate for which it was intended.
- 7. USE RIGHT TOOL.** Don't force small tool or attachment to do the job of a heavy duty tool. Don't use tool for purpose not intended— for example—do not use a circular saw for cutting tree limbs or logs.
- 8. DRESS PROPERLY.** Do not wear loose clothing or jewelry. Loose clothing, draw strings and jewelry can be caught in moving parts. Rubber gloves and non-skid footwear are recommended when working. Wear protective hair covering to contain long hair.
- 9. USE SAFETY GLASSES.** Wear safety glasses or goggles while operating power tools. Also face or dust mask if operation creates dust. All persons in the area where power tools are being operated should also wear safety glasses and face or dust mask.
- 10. DON'T ABUSE CORD.** Never carry tool by cord or yank it to disconnect from receptacle. Keep cord from heat, oil, and sharp edges. Have damaged or worn power cord and strain reliever replaced immediately.

11. **SECURE WORK.** Use clamps or a vise to hold work. It's safer than using your hand and it frees both hands to operate tool.
12. **DON'T OVERREACH.** Keep proper footing and balance at all times.
13. **MAINTAIN TOOLS WITH CARE.** Keep tools sharp and clean for better and safer performance. Follow instructions for lubricating and changing accessories. Inspect tool cords periodically and if damaged, have repaired by authorized service facility. Inspect extension cords periodically and replace if damaged. Have all worn, broken or lost parts replaced immediately. Keep handles dry, clean and free from oil and grease.
14. **DISCONNECT TOOLS.** When not in use, before servicing, and when changing accessories such as blades, bits, cutters, etc.
15. **REMOVE ADJUSTING KEYS AND WRENCHES.** Form habit of checking to see that keys and adjusting wrenches are removed from the tool before turning it on.
16. **AVOID UNINTENTIONAL STARTING.** Don't carry plugged-in tool with finger on switch. Be sure switch is off when plugging in.
17. **OUTDOOR USE EXTENSION CORDS.** When tool is used outdoors, use only extension cords marked "Suitable for use with outdoor appliances - store indoors when not in use."
18. **STAY ALERT.** Watch what you are doing. Use common sense. Do not operate tool when you are tired or while under the influence of medication, alcohol or drugs.
19. **CHECK DAMAGED PARTS.** Before further use of the tool, a guard or other part that is damaged should be carefully checked to determine that it will operate properly and perform its intended function. Check for alignment of moving parts, binding of moving parts, breakage of parts, mounting, and any other conditions that may affect its operation. A guard or other part that is damaged should be properly repaired or replaced by an authorized service center unless otherwise indicated elsewhere in this instruction manual. Have defective switches replaced by authorized service center. Do not use tool if switch does not turn it on and off.

SAVE THESE INSTRUCTIONS

ADDITIONAL SAFETY RULES FOR DISC SANDER/GRINDER

1. **NEVER** use the spindle lock pin to stop the spindle from rotating.
2. **ALWAYS** use guards with those accessories that require such equipment.
3. **ALWAYS** position the guard so that flying chips or pieces of a wheel that might accidentally break will be deflected away from the operator.
4. **MAKE SURE** that grinding wheels, discs, pads, etc., are in good condition, free of cracks or chips and that **RATED SPEED EXCEEDS THAT INDICATED ON THE TOOL SPECIFICATION PLATE.**

REPLACEMENT PARTS

When servicing use only identical replacement parts.

MOTOR

Most Porter-Cable tools will operate on either D.C., or single phase 25 to 60 cycle A.C. current and voltage within plus or minus 5 percent of that shown on the specification plate on the tool. Several models, however, are designed for A.C. current only. Refer to the specification plate on your tool for proper voltage and current rating.

CAUTION: Do not operate your tool on a current on which the voltage is not within correct limits. Do not operate tools rated A.C. only on D.C. current. To do so may seriously damage the tool.

EXTENSION CORD SELECTION

If an extension cord is used, make sure the conductor size is large enough to prevent excessive voltage drop which will cause loss of power and possible motor damage. A table of recommended extension cord sizes will be found below. This table is based on limiting line voltage drop to 5 volts (10 volts for 230 volts) at 150% of rated amperes.

If an extension cord is to be used outdoors it must be marked with the suffix W-A following the cord type designation. For example — SJTW-A to indicate it is acceptable for outdoor use.

RECOMMENDED EXTENSION CORD SIZES FOR USE WITH PORTABLE ELECTRIC TOOLS

		Length of Cord in Feet									
		115V	25 Ft.	50 Ft.	100 Ft.	150 Ft.	200 Ft.	250 Ft.	300 Ft.	400 Ft.	500 Ft.
		230V	50 Ft.	100 Ft.	200 Ft.	300 Ft.	400 Ft.	500 Ft.	600 Ft.	800 Ft.	1000 Ft.
Nameplate Ampere Rating	0-2	18	18	18	16	16	14	14	12	12	
	2-3	18	18	16	14	14	12	12	10	10	
	3-4	18	18	16	14	12	12	10	10	8	
	4-5	18	18	14	12	12	10	10	8	8	
	5-6	18	16	14	12	10	10	8	8	6	
	6-8	18	16	12	10	10	8	6	6	6	
	8-10	18	14	12	10	8	8	6	6	4	
	10-12	16	14	10	8	8	6	6	4	4	
	12-14	16	12	10	8	6	6	6	4	2	
	14-16	16	12	10	8	6	6	4	4	2	
	16-18	14	12	8	8	6	4	4	2	2	
18-20	14	12	8	6	6	4	4	2	2		

OPERATING INSTRUCTIONS

FOREWORD

Your Porter-Cable Disc Sander/Grinder is designed for numerous sanding and grinding operations when used with appropriate recommended accessories.

Typical applications are smoothing rough boards, removing paint and varnish, auto body sanding, smoothing welding beads, removing gates and flash from castings, removing rust, leveling form seams from concrete, and the like.

TO START AND STOP MACHINE

1. Connect machine to power circuit. Make sure power circuit voltage is the same as that shown on the specification plate.
2. Squeeze switch trigger (A) Fig. 1, to start motor. Release trigger to stop motor.

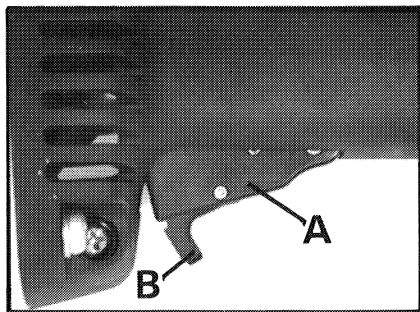

Fig. 1

3. A LOCK BUTTON is provided to keep the motor running without holding the trigger switch ON.

To lock the trigger switch ON, squeeze the trigger (A) while sliding finger forward to engage lock button (B) Fig. 1, and release trigger switch.

To unlock, lock button, squeeze trigger switch (A) and release, allowing lock button free to spring back.

TO INSTALL AUXILIARY HANDLE

An auxiliary handle (H) Fig. 2, is furnished with your machine and can be installed on either side of the front housing. This handle **SHOULD BE USED AT ALL TIMES** to maintain complete control of the machine.

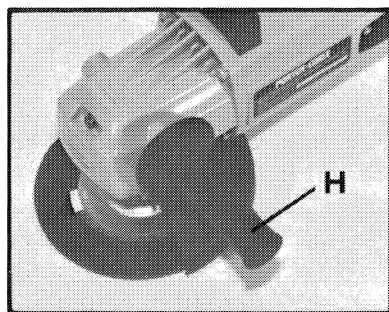

Fig. 2

THE DISC SANDER

When sanding, use an abrasive disc with a flexible backing disc and a quick change backup pad (see Fig. 3). Refer to the back of this manual for a list of available accessories recommended for use with your machine.

TO INSTALL SANDING DISC

1. Disconnect machine from power circuit.
2. Rest machine on tool rest and rear handle.
3. Place washer (E) Fig. 3, on spindle (F).

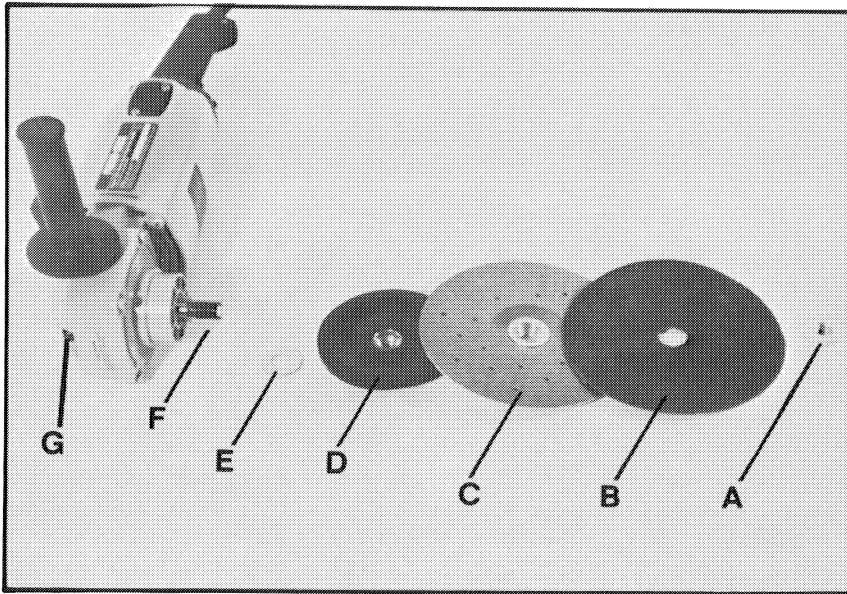

Fig. 3

4. Depress Spindle Lock Pin (G) and rotate Back-up Pad (D) clockwise onto shaft (F) until it seats. Then rotate the flexible disc (C) onto shaft until it seats.
5. Place retaining nut (A) through hole in sanding disc (B) and rotate clockwise on shaft until it seats. Normal operation of the Sander will tighten the Sanding Disc.
6. To remove Sanding Disc, disconnect machine from power source, depress spindle lock pin (G) and rotate sanding disc (B) together with the flexible disc (C) counterclockwise and remove.

USING A DISC SANDER

This machine has a directional arrow cast into the top of the gear housing which indicates the direction any accessory will rotate. See Fig. 6.

1. Secure work to prevent it from moving during the sanding operation. Friction between the sanding disc and work will try to spin work away from sander and may cause bodily injury.
2. Wear Safety Glasses and dust mask.

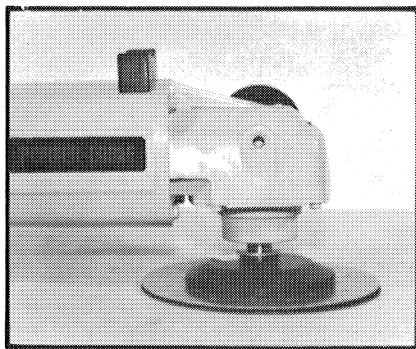

Wrong Pad Position for Sanding

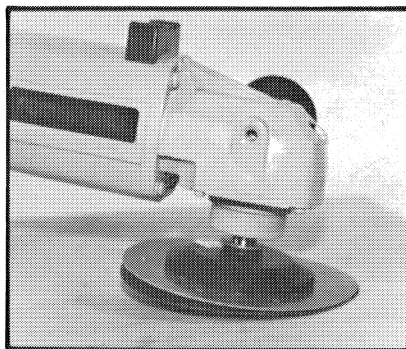

Right Pad Position for Sanding

Fig. 4

3. Hold sander firmly by the rear and auxiliary handles, making sure sanding disc is clear of work and foreign objects. Start sander and lower at an angle so that approximately 1" to 1¼" of the sanding disc contacts the work. See Fig. 4. Too great an angle may result in gouging or snagging the work, while too small an angle results in extreme difficulties in controlling the sander.

4. Move sander in long sweeping overlapping strokes as you go back and forth. Do not move sander in a circular motion or stay in one spot too long as this will produce swirls and an uneven finish. The weight of the sander applies sufficient pressure for fast stock removal. Additional pressure will only slow the sander down and decrease removal of stock.

5. Lift sander from work before turning off motor.

6. Always be sure motor has stopped before setting sander down. A tool rest is provided on the top of the sander for resting the sander upside down when not in use.

SANDING TIPS

For rough sanding and quick stock removal, use a coarse grit sanding disc. For a fine finish, use a medium grit disc, followed by a fine grit disc. Do not go directly from a coarse grit to a fine grit, as it is difficult to remove marks left by the coarse grit disc.

THE GRINDER

When disc grinding, use a depressed center wheel with a wheel adapter and wheel guard. (See Fig. 6). **ALWAYS USE A WHEEL GUARD OF THE CORRECT SIZE WITH DEPRESSED CENTER WHEEL.** Refer to the back of this manual for a list of available accessories recommended for use with your machine.

INSTALLING DEPRESSED CENTER WHEEL GUARD

1. Disconnect machine from power circuit.
2. Rest machine on tool rest and rear handle.
3. Loosen clamp nuts (A) Fig. 5, and slip guard clamp (B) over gear housing cover collar.

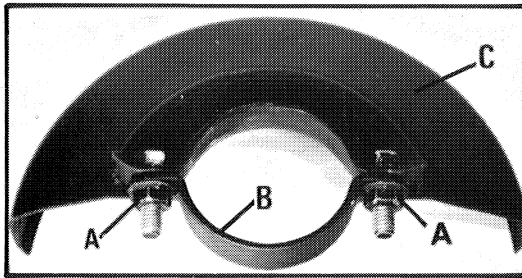

Fig. 5

4. Position the guard (C), so that flying chips or pieces of wheel that might accidentally break will be deflected away from the operator. Fig. 6 shows the guard installed for use with depressed center grinding wheel.

5. Firmly tighten clamp nuts (A) Fig. 5.

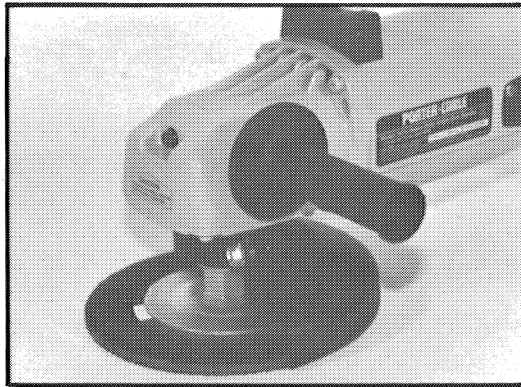

Fig. 6

INSTALLING DEPRESSED CENTER WHEEL

1. Disconnect machine from power circuit.
2. Rest machine on tool rest and rear handle.
3. Assemble wheel guard by following instructions listed under INSTALLING DEPRESSED CENTER WHEEL GUARD.
4. Place washer (A) Fig. 7, on spindle (B).
5. Thread wheel adapter (C) to shaft shoulder with flange face outward. CAUTION - For ease of wheel adapter removal, hand tighten only.

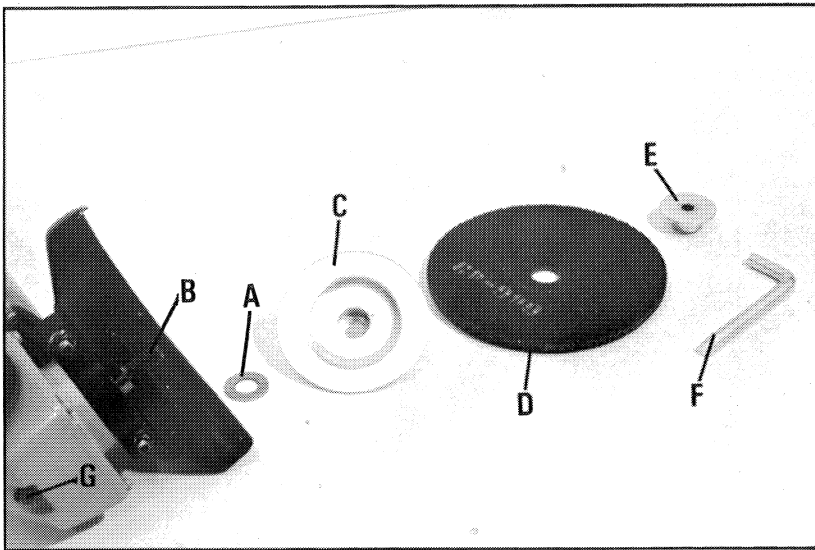

Fig. 7

6. Mount depressed center wheel (D) and thread wheel nut (E) to spindle and tighten with hex wrench (F).
7. To secure wheel nut (E), depress the spindle lock pin (G) while holding the machine in one hand. Then tighten the nut using the hex wrench by rotating it in a clockwise direction with the other hand.
8. To remove, reverse the foregoing procedure.

SMOOTHING WELDING BEADS, CASTING GATES, CASTING FLASHES, ETC.

Use depressed center grinding wheel with wheel adapter kit and safety guard (see Fig. 6). ALWAYS USE SAFETY GUARD WITH DEPRESSED CENTER GRINDING WHEEL. The guard shall be positioned so that flying chips or pieces of a wheel that might accidentally break will be deflected away from the operator. Install auxiliary handle in either side of the gear housing. Firmly grip the auxiliary and rear handles. Lift up rear handle so only the front sector of the grinding wheel contacts work before starting or stopping the motor. When the grinder is not being used, rest it on the tool rest and rear handle.

INSTALLING FLARING CUP WHEEL GUARD AND FLARING CUP WHEEL

1. Disconnect machine from power circuit.
2. Rest machine on tool rest and rear handle.
3. Place washer (A) Fig. 8, on spindle as shown.
4. Mount the guard (B) by sliding clamp over gear housing collar.

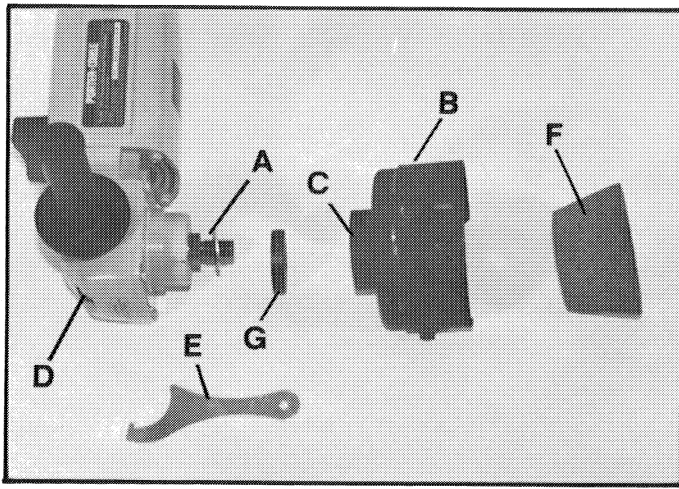

Fig. 8

5. Position the guard so that flying chips or pieces of wheel that might accidentally break will be deflected away from the operator. Note - Fig. 9 shows guard installed for use with the flaring cup wheel.
6. Firmly tighten clamp nut (C) Fig. 8.
7. Depress spindle lock pin (D) Fig. 8, and thread backup flange (G) to spindle with counterbored side toward machine. Tighten firmly with the spanner wrench (E) provided.
8. **Note:** Flaring cup wheels are available from local suppliers. Use a wheel with $\frac{5}{8}$ - 11 mounting threads and a rated speed higher than the rated speed of your machine.

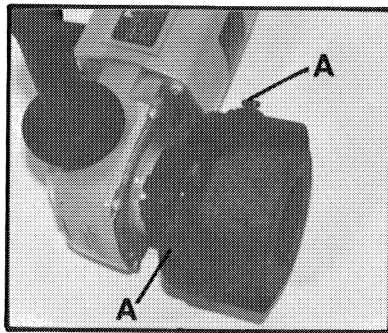

Fig. 9

9. Loosen skirt adjusting screws (A) Fig. 9, and adjust skirt so that it is flush with the bottom of the grinding wheel. Tighten screws securely. NOTE: As grinding wheel wears readjust skirt as required.
10. To remove flaring cup wheel, disconnect machine from power source, depress spindle lock pin and revolve wheel until lock pin seats in spindle. Using a strap wrench, turn wheel counterclockwise to loosen and remove.

11. Loosen clamp nut on wheel guard and remove guard from gear housing.

12. To remove backup flange, depress spindle lock pin and revolve flange until lock pin seats in spindle. Using spanner wrench provided, turn flange counterclockwise to loosen and remove.

LEVELING FORM SEAMS FROM CONCRETE, ETC.

Use flaring cup wheel and flaring cup wheel guard. For installation see **INSTALLING FLARING CUP WHEEL GUARD AND FLARING CUP WHEEL.**

MAINTENANCE

KEEP TOOL CLEAN

Periodically blow out all air passages with compressed air. Wear safety glasses while performing this operation. All plastic parts should be cleaned with soft damp cloth. NEVER use solvents, to clean plastic parts. They could possibly dissolve or otherwise damage the material.

FAILURE TO START

Should your tool fail to start, check to make sure the prongs on the cord plug are making good contact in the outlet. Also, check for blown fuses or open circuit breakers in the line.

BRUSH INSPECTION AND LUBRICATION

Because this model is "Double Insulated" which provides two complete sets of insulation to protect the user from the electric current within the tool, brush inspection and replacement should ONLY be performed by an AUTHORIZED PORTER-CABLE SERVICE STATION.

At approximately 100 hours of use, take or send your tool to your nearest Authorized Porter-Cable Service Station to be thoroughly cleaned and inspected; worn parts replaced, when necessary; re-lubricated with fresh lubricant, if required; reassembled with new brushes; and performance tested.

Any loss of power before the above maintenance check may indicate the need for immediate servicing of your tool. DO NOT CONTINUE TO OPERATE TOOL UNDER THIS CONDITION. If proper operating voltage is present, return your tool to the Service Station for immediate service.

SERVICE AND REPAIRS

All quality tools will eventually require servicing or replacement of parts due to wear from normal use. These operations, including brush inspection and replacement, should ONLY be performed by either an AUTHORIZED PORTER-CABLE SERVICE STATION or a PORTER-CABLE SERVICE CENTER. All repairs made by these

agencies are fully guaranteed against defective material and workmanship. We can not guarantee repairs made or attempted by anyone other than these agencies.

Should you have any questions about your tool, feel free to write us at any time. In any communications, please give all information shown on the nameplate of your tool (model number, type, serial number, etc.).

ACCESSORIES

The testing of this tool has been accomplished with the following accessories. For safety operation, it is recommended that only these accessories be used with this product.

WARNING - Since accessories other than those listed have not been tested with this product, use of such accessories could be hazardous.

ACCESSORY EQUIPMENT FOR ANGLE DISC SANDERS Abrasive Disc Backup System

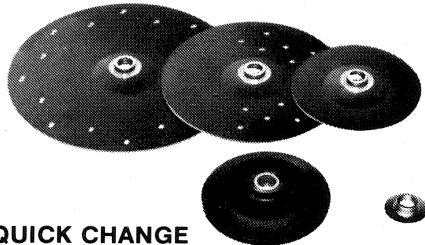

QUICK CHANGE WRENCHLESS ACCESSORIES

The rubber backup pad and the disc itself thread on to the spindle making abrasive disc removal a cinch. By holding the phenolic disc with the finger, the retaining nut can be loosened by simply turning the abrasive disc counterclockwise.

No. 55741 - 7" abrasive backup kit. Includes pad, disc and nut.

No. 55742 - 9" abrasive backup kit. Includes pad, disc and nut.

No. 55747 - abrasive retaining nut - replacement nut.

**ACCESSORY EQUIPMENT TO
CONVERT ANGLE SANDERS
TO GRINDERS**

WHEEL GUARD ASSEMBLY

Used with depressed
center wheels.

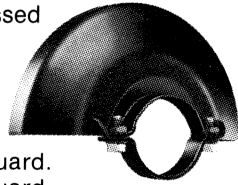

No. 54342 - 7" guard.

No. 54343 - 9" guard.

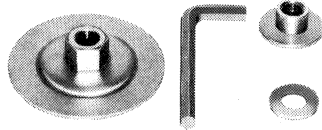

No. 54347 - Depressed center wheel backup kit. Designed especially for more stability to reduce vibration and obtain smoother grinding. Kit includes backup hub, 54348 retaining nut, retaining nut wrench and spacing washer.

No. 54348 - Depressed center wheel retaining nut. Replacement nut for 54347 backup kit.

**Guards must be used with all depressed Center Wheels.*

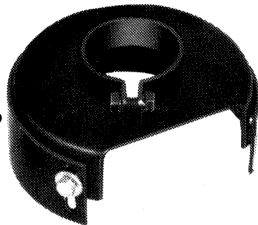

**FLARED CUP
WHEEL
GUARDS**

New style extra safe guards complying with ANSI B7.1-1978 safety standard. These guards protect the operator by shielding better than half of the grinding wheel. The shield is adjustable as the wheel wears down. Each is equipped with 54349 threaded cup wheel backup flange and spanner wrench.

No. 54349 - Cup wheel flange. $\frac{5}{8}$ " - 11 threaded flange for use as backup for 4", 5" and 6" abrasive cup wheels.

No. 54350 - 4" cup wheel guard.

No. 54351 - 5" cup wheel guard.

No. 54352 - 6" cup wheel guard.

**PORTER-CABLE LIMITED
ONE YEAR WARRANTY**

Porter-Cable warrants its Professional Power Tools for a period of one year from the date of original purchase. We will repair or replace at our option, any part or parts of the product and accessories covered under this warranty which examination proves to be defective in workmanship or material during the warranty period. For repair or replacement return the complete tool or accessory, transportation prepaid, to your nearest Porter-Cable Service Center or Authorized Service Station as listed under "TOOLS-ELECTRIC" in the Yellow Pages of your telephone directory. Proof of purchase may be required. This warranty does not apply to repair or replacement required due to misuse, abuse, normal wear and tear or repairs attempted or made by other than our Service Centers or Authorized Service Stations.

To obtain information on warranty performance please write to: PORTER-CABLE CORPORATION, Youngs Crossing At Highway 45, P.O. BOX 2468, Jackson, Tennessee 38301; Attention: Product Service. The foregoing obligation is Porter-Cable's sole liability under this or any implied warranty and under no circumstances shall Porter-Cable be liable for any incidental or consequential damages. Some states do not allow limitations on how long an implied warranty lasts on the exclusion or limitation of incidental or consequential damages, so the above limitation or exclusion may not apply to you.

This warranty gives you specific legal rights and you may also have other legal rights which vary from state to state.

PORTER-CABLE SERVICE CENTERS

Parts and Repair Service for Porter-Cable Power Tools
are Available at These Locations

ALABAMA

Birmingham 35209
Suite 105
131 West Oxmoor Road
Phone: (205) 942-6325

CALIFORNIA

Los Angeles 90007
2400 South Grand Avenue
Phone: (213) 749-0386

Orange 92668
385 North Anaheim Blvd.
Phone: (714) 634-4111

Santa Clara 95050
2305 De La Cruz Boulevard
Phone: (408) 727-9790

San Leandro 94577
3039 Teagarden Street
Phone: (415) 357-9762

COLORADO

Denver 80207
4900 East 39th Avenue
Phone: (303) 388-5803

CONNECTICUT

Manchester 06040 (Hartford)
57 Tolland Turnpike
Phone: (203) 646-1078

FLORIDA

Hialeah 33014
16373-75 NW 57th Ave.
Phone: (305) 624-2523

Jacksonville 32205
517 Cassat Avenue
Phone: (904) 387-4455

Tampa 33609
4538 W. Kennedy Boulevard
Phone: (813) 877-9585

Orlando 32803
1807½ Winter Park Road
Phone: (305) 644-8100

GEORGIA

Forest Park 30050 (Atlanta)
4017 Jonesboro Road
Phone: (404) 363-8000

ILLINOIS

Melrose Park 60160 (Chicago)
4533 West North Avenue
Phone: (312) 345-8900

INDIANA

Indianapolis 46268
5317 West 86th Street
Park 100—Building 6
Phone: (317) 875-9078

LOUISIANA

Kenner 70062 (New Orleans)
2440-0 Veterans Memorial Blvd.
Phone: (504) 469-7363

MARYLAND

Baltimore 21205
4714 Erdman Avenue
Phone: (301) 483-3100

Hyattsville 20781
4811 Kenilworth Avenue
Phone: (301) 779-8080

MASSACHUSETTS

Allston 02134 (Boston)
414 Cambridge Street
Phone: (617) 782-1700

MICHIGAN

Grand Rapids 49506
Indian Village Mall
2750 Birchcrest Drive S.E.
Phone: (616) 949-9040

Southfield 48037 (Detroit)
18650 W. Eight Mile Road
Phone: (313) 569-4333

MINNESOTA

Minneapolis 55429
4315 68th Avenue North
Phone: (612) 561-9080

MISSOURI

North Kansas City 64116
1141 Swift Avenue
Phone: (816) 221-2070
St. Louis 63139
2348 Hampton Avenue
Phone: (314) 644-3166

NEW JERSEY

Union 07083
945 Ball Avenue
Phone: (201) 964-1730

NEW YORK

New York 10013 (Manhattan)
132 Lafayette Street
Phone: (212) 966-2726

Flushing 11365
175-25 Horace Harding Expwy.
Phone: (212) 225-2040

Syracuse 13224
2740 Erie Blvd. East
Phone: (315) 445-1922

NORTH CAROLINA

Charlotte 28209
4612 South Boulevard
Phone: (704) 525-4410

OHIO

Columbus 43214
4560 Indianola Avenue
Phone: (614) 263-0929

OKLAHOMA

Oklahoma City 73107
3631 Northwest 23rd Street
Phone: (405) 946-5437

OREGON

Portland 97212
51 N.E. Hancock
Phone: (503) 288-6888

PENNSYLVANIA

Ben Salem 19020
I-95 Industrial Center
3599 Meadow Lane
Phone: (215) 638-4114

RHODE ISLAND

East Providence 02914
1009 Waterman Avenue
Phone: (401) 434-3620

TENNESSEE

Memphis 38116
1004 East Brooks Road
Phone: (901) 332-1353

TEXAS

Dallas 75247
3160 Commonwealth Drive
Suite 180, Commonwealth Plaza
Phone: (214) 631-7855

Houston 77092
5201 Mitchelldale B-9
Phone: (713) 682-0334

San Antonio 78218
Suite 107
2800 N.E. Loop 410
Phone: (512) 654-1061

UTAH

Salt Lake City 84115
2990 Southwest Temple
Phone: (801) 487-4953

VIRGINIA

Richmond 23230
1705 Dabney Road
Phone: (804) 257-7348

WASHINGTON

Seattle 98101
1918 Minor Avenue
Phone: (206) 622-4576

WISCONSIN

Milwaukee 53222
10700 W. Burleigh Street
Phone: (414) 774-3650

Authorized Porter-Cable Service Stations are located in all large cities. For the one nearest you, see the classified section in your phone book (under "Tools - Electric").

Printed in U.S.A.

Free Manuals Download Website

<http://myh66.com>

<http://usermanuals.us>

<http://www.somanuals.com>

<http://www.4manuals.cc>

<http://www.manual-lib.com>

<http://www.404manual.com>

<http://www.luxmanual.com>

<http://aubethermostatmanual.com>

Golf course search by state

<http://golfingnear.com>

Email search by domain

<http://emailbydomain.com>

Auto manuals search

<http://auto.somanuals.com>

TV manuals search

<http://tv.somanuals.com>