

Instruction Manual

10" Compound Laser Miter Saw

TWIN LASER™



MODEL 3700L

To learn more about Porter-Cable
visit our website at:

<http://www.porter-cable.com>

PORTER-CABLE
PROFESSIONAL POWER TOOLS

IMPORTANT

*Please make certain that the person who is to use
this equipment carefully reads and understands
these instructions before starting operations.*

The Model and Serial No. plate is located on the main
housing of the tool. Record these numbers in the
spaces below and retain for future reference.

Model No. _____

Type _____

Serial No. _____

TABLE OF CONTENTS

IMPORTANT SAFETY INSTRUCTIONS	2
SAFETY GUIDELINES	3
GENERAL SAFETY RULES	4
ADDITIONAL SPECIFIC SAFETY RULES	5
FUNCTIONAL DESCRIPTION	6
CARTON CONTENTS	7
ASSEMBLY	7
OPERATION	10
TROUBLESHOOTING	20
MAINTENANCE	20
SERVICE	21
ACCESSORIES	21
WARRANTY	22
ESPAÑOL	23
FRANÇAISE	45
SERVICE CENTER LOCATIONSback cover

IMPORTANT SAFETY INSTRUCTIONS

▲ WARNING Read and understand all warnings and operating instructions before using any tool or equipment. When using tools or equipment, basic safety precautions should always be followed to reduce the risk of personal injury. Improper operation, maintenance or modification of tools or equipment could result in serious injury and property damage. There are certain applications for which tools and equipment are designed. Porter Cable strongly recommends that this product NOT be modified and/or used for any application other than for which it was designed.

If you have any questions relative to its application DO NOT use the product until you have written Porter Cable and we have advised you.

Online contact form at <http://www.porter-cable.com>

Postal Mail: Technical Service Manager
Porter Cable
4825 Highway 45 North
Jackson, TN 38305

Information regarding the safe and proper operation of this tool is available from the following sources:

Power Tool Institute
1300 Sumner Avenue, Cleveland, OH 44115-2851
www.powertoolinstitute.org

National Safety Council
1121 Spring Lake Drive, Itasca, IL 60143-3201

American National Standards Institute, 25 West 43rd Street, 4 floor, New York, NY 10036 www.ansi.org
ANSI 01.1 Safety Requirements for Woodworking Machines, and

the U.S. Department of Labor regulations www.osha.gov

SAVE THESE INSTRUCTIONS!

SAFETY GUIDELINES - DEFINITIONS

It is important for you to read and understand this manual. The information it contains relates to protecting YOUR SAFETY and PREVENTING PROBLEMS. The symbols below are used to help you recognize this information.

- ▲ DANGER** Indicates an imminently hazardous situation which, if not avoided, will result in death or serious injury.
 - ▲ WARNING** Indicates a potentially hazardous situation which, if not avoided, could result in death or serious injury.
 - ▲ CAUTION** Indicates a potentially hazardous situation which, if not avoided, may result in minor or moderate injury.
 - CAUTION** Used without the safety alert symbol indicates potentially hazardous situation which, if not avoided, may result in property damage.
-

CALIFORNIA PROPOSITION 65

▲ WARNING **SOME DUST CREATED BY POWER SANDING, SAWING, GRINDING, DRILLING, AND OTHER CONSTRUCTION ACTIVITIES** contains chemicals known to cause cancer, birth defects or other reproductive harm.

Some examples of these chemicals are:

- lead from lead-based paints,
- crystalline silica from bricks and cement and other masonry products, and
- arsenic and chromium from chemically-treated lumber.

Your risk from these exposures varies, depending on how often you do this type of work. To reduce your exposure to these chemicals: work in a well ventilated area, and work with approved safety equipment, always wear **MSHA/NIOSH** approved, properly fitting face mask or respirator when using such tools.

GENERAL SAFETY RULES



⚠ WARNING READ AND UNDERSTAND ALL WARNINGS AND OPERATING INSTRUCTIONS BEFORE USING THIS EQUIPMENT. Failure to follow all instructions listed below, may result in electric shock, fire, and/or serious personal injury or property damage.

IMPORTANT SAFETY INSTRUCTIONS

- FOR YOUR OWN SAFETY, READ INSTRUCTION MANUAL BEFORE OPERATING THE TOOL.** Learn the tool's application and limitations as well as the specific hazards peculiar to it.
- KEEP GUARDS IN PLACE** and in working order.
- ALWAYS WEAR EYE PROTECTION.** Wear safety glasses. Everyday eyeglasses only have impact resistant lenses; they are not safety glasses. Also use face or dust mask if cutting operation is dusty. These safety glasses must conform to ANSI Z87.1 requirements. **NOTE:** Approved glasses have Z87 printed or stamped on them.
- REMOVE ADJUSTING KEYS AND WRENCHES.** Form habit of checking to see that keys and adjusting wrenches are removed from tool before turning it "on".
- KEEP WORK AREA CLEAN.** Cluttered areas and benches invite accidents.
- DON'T USE IN DANGEROUS ENVIRONMENT.** Don't use power tools in damp or wet locations, or expose them to rain. Keep work area well-lighted.
- KEEP CHILDREN AND VISITORS AWAY.** All children and visitors should be kept a safe distance from work area.
- MAKE WORKSHOP CHILDPROOF** – with padlocks, master switches, or by removing starter keys.
- DON'T FORCE TOOL.** It will do the job better and be safer at the rate for which it was designed.
- USE RIGHT TOOL.** Don't force tool or attachment to do a job for which it was not designed.
- WEAR PROPER APPAREL.** No loose clothing, gloves, neckties, rings, bracelets, or other jewelry to get caught in moving parts. Nonslip footwear is recommended. Wear protective hair covering to contain long hair.
- SECURE WORK.** Use clamps or a vise to hold work when practical. It's safer than using your hand and frees both hands to operate tool.
- DON'T OVERREACH.** Keep proper footing and balance at all times.
- MAINTAIN TOOLS IN TOP CONDITION.** Keep tools sharp and clean for best and safest performance. Follow instructions for lubricating and changing accessories.
- DISCONNECT TOOLS** before servicing and when changing accessories such as blades, bits, cutters, etc.
- USE RECOMMENDED ACCESSORIES.** The use of accessories and attachments not recommended by Porter-Cable may cause hazards or risk of injury to persons.
- REDUCE THE RISK OF UNINTENTIONAL STARTING.** Make sure switch is in "OFF" position before plugging in power cord. In the event of a power failure, move switch to the "OFF" position.
- NEVER STAND ON TOOL.** Serious injury could occur if the tool is tipped or if the cutting tool is accidentally contacted.
- CHECK DAMAGED PARTS.** Before further use of the tool, a guard or other part that is damaged should be carefully checked to ensure that it will operate properly and perform its intended function – check for alignment of moving parts, binding of moving parts, breakage of parts, mounting, and any other conditions that may affect its operation. A guard or other part that is damaged should be properly repaired or replaced.
- DIRECTION OF FEED.** Feed work into a blade or cutter against the direction of rotation of the blade or cutter only.
- NEVER LEAVE TOOL RUNNING UNATTENDED. TURN POWER OFF.** Don't leave tool until it comes to a complete stop.
- STAY ALERT, WATCH WHAT YOU ARE DOING, AND USE COMMON SENSE WHEN OPERATING A POWER TOOL. DO NOT USE TOOL WHILE TIRED OR UNDER THE INFLUENCE OF DRUGS, ALCOHOL, OR MEDICATION.** A moment of inattention while operating power tools may result in serious personal injury.
- MAKE SURE TOOL IS DISCONNECTED FROM POWER SUPPLY** while motor is being mounted, connected or reconnected.
- THE DUST GENERATED** by certain woods and wood products can be injurious to your health. Always operate machinery in well ventilated areas and provide for proper dust removal. Use wood dust collection systems whenever possible.

SAVE THESE INSTRUCTIONS.

**Refer to them often and
use them to instruct others.**

ADDITIONAL SAFETY RULES FOR MITER SAWS

▲ WARNING FAILURE TO FOLLOW THESE RULES MAY RESULT IN SERIOUS PERSONAL INJURY.

1. **DO NOT OPERATE THIS MACHINE UNTIL** it is assembled and installed according to the instructions.
2. **OBTAIN ADVICE from your supervisor, instructor, or another qualified person** if you are not familiar with the operation of this machine.
3. **FOLLOW ALL WIRING CODES** and recommended electrical connections.
4. **MOUNT THE TOOL SECURELY** to a stable supporting surface prior to operation
5. **USE THE GUARDS WHENEVER POSSIBLE.** Check to see that they are in place, secured, and working correctly.
6. **USE ONLY CROSSCUT SAW BLADES.** Use only zero-degree or negative hook angles when using carbide-tipped blades. Do not use blades with deep gullets. These can deflect and contact the guard.
7. **USE ONLY BLADES OF THE CORRECT SIZE AND TYPE** specified for this tool.
8. **USE A SHARP BLADE.** Check blade to see if it runs freely and is free from vibration.
9. **INSPECT BLADE FOR CRACKS** or other damage prior to operation. Replace cracked or damaged blade immediately.
10. **CLEAN THE BLADE AND BLADE FLANGES** prior to operation. Check for any damage and tighten the arbor nut securely.
11. **USE ONLY BLADE FLANGES** specified for this tool.
12. **CLEAR THE AREA OF FLAMMABLE LIQUIDS** and/or gas prior to operation.
13. **CLEAN THE MOTOR AIR SLOTS** of chips and sawdust.
14. **TIGHTEN THE TABLE CLAMP HANDLE** and any other clamps prior to operation.
15. **NEVER START THE TOOL** with the workpiece against the blade.
16. **KEEP HANDS out of path** of saw blade. Clamp all workpieces that would require your hand to be in the "Table Hazard Zone" (within the red lines).
17. **ALLOW THE MOTOR to come to full speed** prior to starting cut.
18. **NEVER REACH AROUND** or behind the saw blade.
19. **NEVER CUT FERROUS METALS** or masonry.
20. **NEVER RECUT SMALL PIECES.**
21. **NEVER LOCK THE SWITCH** in the "ON" position.
22. **NEVER APPLY LUBRICANT** to a running blade.
23. **DO NOT PERFORM FREE-HAND OPERATIONS.** Hold the work firmly against the fence and table. Use clamps to hold the work when possible.
24. **PROPERLY SUPPORT LONG** or wide workpieces.
25. **AFTER COMPLETING CUT,** release power switch and wait for coasting blade to come to a complete stop before returning saw to raised position.
26. **TURN OFF TOOL AND ALLOW THE BLADE TO COME TO A COMPLETE STOP** prior to cleaning the blade area or removing debris in the path of the blade. A coasting blade can be dangerous.
27. **TURN OFF TOOL AND ALLOW BLADE TO COME TO A COMPLETE STOP** before removing or securing workpiece, changing workpiece angle, or changing the angle of the blade.
28. **NEVER PERFORM LAYOUT, ASSEMBLY,** or set-up work on the table/work area when the machine is running.
29. **TURN THE MACHINE "OFF" AND DISCONNECT THE MACHINE** from the power source before installing or removing accessories, before adjusting or changing set-ups, or when making repairs.
30. **TURN THE MACHINE "OFF",** disconnect the machine from the power source, and clean the table/work area before leaving the machine. **LOCK THE SWITCH IN THE "OFF" POSITION** to prevent unauthorized use.
31. **ADDITIONAL INFORMATION** regarding the safe and proper operation of this tool is available from the Power Tool Institute, 1300 Summer Avenue, Cleveland, OH 44115-2851. Information is also available from the National Safety Council, 1121 Spring Lake Drive, Itasca, IL 60143-3201. Please refer to the American National Standards Institute ANSI O1.1 Safety Requirements for Woodworking Machines and the U.S. Department of Labor OSHA 1910.213 Regulations.

ADDITIONAL SAFETY RULES FOR THE LASER

1. **▲ CAUTION** **LASER LIGHT - DO NOT STARE INTO BEAM,** APERTURE, or into a reflection from a mirror-like surface Figs. 1 and 1A.
2. **▲ CAUTION** **AVOID EXPOSURE - LASER LIGHT IS EMITTED FROM FRONT GUARD APERTURE.** Use of controls or adjustments, or performance of procedures other than those specified herein may result in hazardous laser light exposure.
3. **▲ CAUTION** **DO NOT DISASSEMBLE LASER MODULE.** The laser is a CLASS II LASER PRODUCT that can emit laser power up to 1 mW MAX at 635 nm, which could result in exposure with the module disassembled. The laser unit complies with 21 CFR 1040.10 and 1040.11.
4. **▲ CAUTION** **USE OF CONTROLS OR ADJUSTMENTS OR PERFORMANCE OF PROCEDURES OTHER THAN THOSE SPECIFIED HEREIN MAY RESULT IN HAZARDOUS RADIATION EXPOSURE.**

SAVE THESE INSTRUCTIONS. Refer to them often and use them to instruct others.



Fig. 1

AVOID EXPOSURE -
Laser radiation is emitted
← from this aperture.

907771

Fig. 1A

POWER CONNECTIONS

A separate electrical circuit should be used for your machines. This circuit should not be less than #12 wire and should be protected with a 20 Amp time lag fuse. If an extension cord is used, use only 3-wire extension cords which have 3-prong grounding type plugs and matching receptacle which will accept the machine's plug. Before connecting the machine to the power line, make sure the switch (s) is in the "OFF" position and be sure that the electric current is of the same characteristics as indicated on the machine. All line connections should make good contact. Running on low voltage will damage the machine.

⚠ DANGER DO NOT EXPOSE THE MACHINE TO RAIN OR OPERATE THE MACHINE IN DAMP LOCATIONS.

MOTOR SPECIFICATIONS

Your machine is wired for 120V, 60 HZ alternating current. Before connecting the machine to the power source, make sure the switch is in the "OFF" position.

GROUNDING INSTRUCTIONS

⚠ DANGER THIS MACHINE MUST BE GROUNDED WHILE IN USE TO PROTECT THE OPERATOR FROM ELECTRIC SHOCK.

1. All grounded, cord-connected machines:

In the event of a malfunction or breakdown, grounding provides a path of least resistance for electric current to reduce the risk of electric shock. This machine is equipped with an electric cord having an equipment-grounding conductor and a grounding plug. The plug must be plugged into a matching outlet that is properly installed and grounded in accordance with all local codes and ordinances.

Do not modify the plug provided - if it will not fit the outlet, have the proper outlet installed by a qualified electrician.

Improper connection of the equipment-grounding conductor can result in risk of electric shock. The conductor with insulation having an outer surface that is green with or without yellow stripes is the equipment-grounding conductor. If repair or replacement of the electric cord or plug is necessary, do not connect the equipment-grounding conductor to a live terminal.

Check with a qualified electrician or service personnel if the grounding instructions are not completely understood, or if in doubt as to whether the machine is properly grounded.

Use only 3-wire extension cords that have 3-prong grounding type plugs and matching 3-conductor receptacles that accept the machine's plug, as shown in Fig. A.

Repair or replace damaged or worn cord immediately.

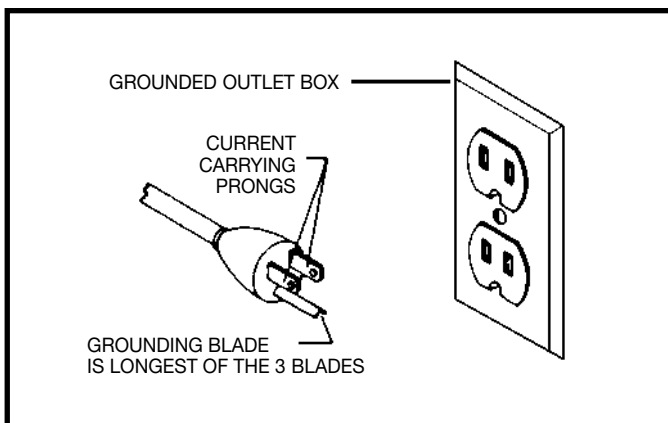

Fig. A

2. Grounded, cord-connected machines intended for use on a supply circuit having a nominal rating less than 150 volts:

If the machine is intended for use on a circuit that has an outlet that looks like the one illustrated in Fig. A, the machine will have a grounding plug that looks like the plug illustrated in Fig. A. A temporary adapter, which looks like the adapter illustrated in Fig. B, may be used to connect this plug to a matching 2-conductor receptacle as shown in Fig. B if a properly grounded outlet is not available. The temporary adapter should be used only until a properly grounded outlet can be installed by a qualified electrician. The green-colored rigid ear, lug, and the like, extending from the adapter must be connected to a permanent ground such as a properly grounded outlet box. Whenever the adapter is used, it must be held in place with a metal screw.

NOTE: In Canada, the use of a temporary adapter is not permitted by the Canadian Electric Code.

⚠ DANGER IN ALL CASES, MAKE CERTAIN THE RECEPTACLE IN QUESTION IS PROPERLY GROUNDED. IF YOU ARE NOT SURE HAVE A QUALIFIED ELECTRICIAN CHECK THE RECEPTACLE.

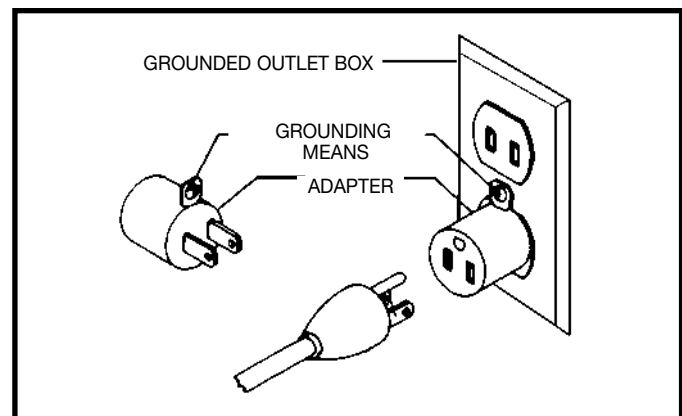

Fig. B

EXTENSION CORDS

⚠ WARNING Use proper extension cords. Make sure your extension cord is in good condition and is a 3-wire extension cord which has a 3-prong grounding type plug and matching receptacle which will accept the machine's plug. When using an extension cord, be sure to use one heavy enough to carry the current of the machine. An undersized cord will cause a drop in line voltage, resulting in loss of power and overheating. Fig. D shows the correct gauge to use depending on the cord length. If in doubt, use the next heavier gauge. The smaller the gauge number, the heavier the cord.

MINIMUM GAUGE EXTENSION CORD			
RECOMMENDED SIZES FOR USE WITH STATIONARY ELECTRIC MACHINES			
Ampere Rating	Volts	Total Length of Cord in Feet	Gauge of Extension Cord
0-6	120	up to 25	18 AWG
0-6	120	25-50	16 AWG
0-6	120	50-100	16 AWG
0-6	120	100-150	14 AWG
6-10	120	up to 25	18 AWG
6-10	120	25-50	16 AWG
6-10	120	50-100	14 AWG
6-10	120	100-150	12 AWG
10-12	120	up to 25	16 AWG
10-12	120	25-50	16 AWG
10-12	120	50-100	14 AWG
10-12	120	100-150	12 AWG
12-16	120	up to 25	14 AWG
12-16	120	25-50	12 AWG
12-16	120	GREATER THAN 50 FEET NOT RECOMMENDED	

Fig. D

FUNCTIONAL DESCRIPTION

FOREWORD

Porter-Cable Model 3700L is a high capacity, 10" compound laser miter saw designed to cut wood and non-ferrous metals. This unit incorporates the latest technology TwinLaser™ line-of-cut indicator feature. It can crosscut 5-1/2" x 2-3/8" and 3-1/2" x 3-1/16", miter at 45° right 3-3/8" x 3-1/16", miter at 45° left 2-5/8" x 3-7/16", bevel at 45° left 5-1/2" x 1-9/16" and 3-5/8" x 1-7/8", and compound 45° x 45°, 3-15/16" x 1-9/16" and 2-7/16" x 2-13/64". It has positive miter stops at 0°, 15°, 22.5°, 30°, and 45° both left and right, and bevel stops at 0° and 45° left.

NOTICE: The photo on the manual cover illustrates the current production model. All other illustrations contained in the manual are representative only and may not depict the actual color, labeling, or accessories, and are intended to illustrate technique only.

CARTON CONTENTS

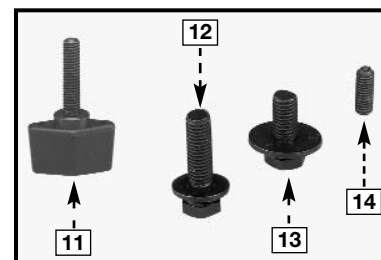
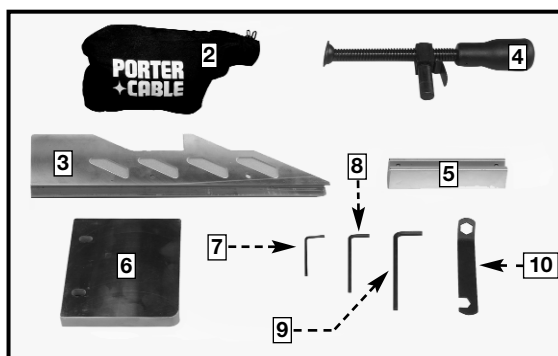
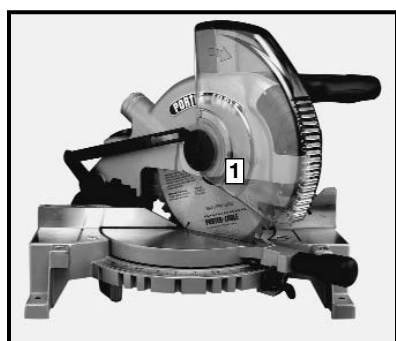

- | | |
|------------------------|-----------------------------------|
| 1. Miter Saw | 9. 5mm Hex Wrench |
| 2. Dust bag | 10. Arbor and Fence Wrench |
| 3. Fence slide | 11. Fence Clamping Screw |
| 4. Clamp | 12. M8 x 1.25 x 30 Hex Head Screw |
| 5. Fence slide support | 13. M8 x 1.25 x 20 Hex Head Screw |
| 6. Extension table | 14. M6 x 1.0 x 16 Set Screw |
| 7. 3mm hex wrench | |
| 8. 1/8" Hex Wrench | |

UNPACKING AND CLEANING

1. Carefully remove the machine from the carton. Retain all packing materials until you have inspected and satisfactorily operated the machine.

⚠ WARNING Do not operate this machine until you read and understand the entire instruction manual.

2. Place the machine on a firm, level surface with extra room for handling and proper support of the workpiece.
3. Familiarize yourself with all features and controls explained in this manual.
4. The machine is shipped with the cuttinghead locked in the down position and the table rotated to 45° left, Fig. 2. To release the head and move it to the operating position, see **“MOVING CUTTINGHEAD TO THE UP POSITION”** and **“MOVING THE TABLE TO THE 0° CUT-OFF POSITION”** in this manual (Fig. 5 & 7).

ASSEMBLY

ASSEMBLY TOOLS REQUIRED

Arbor and fence wrench (supplied)
3mm Hex wrench (supplied)
1/8" Hex Wrench (supplied)

5mm Hex Wrench (Supplied)
Phillips Screwdriver

ASSEMBLY TIME ESTIMATE

Assembly time for this unit is approximately 30 minutes.

MOVING THE CUTTINGHEAD TO THE UP POSITION

1. Pull out the cuttinghead lockpin (A) Fig. 1, and move the cuttinghead (B) to the up position.
2. Fig. 2 shows a close-up of the lockpin (A) pulled out and the cuttinghead (B) in the up position.

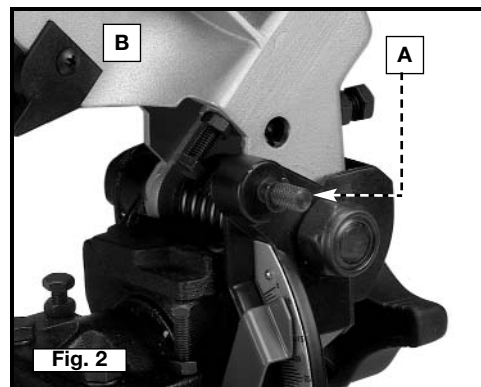
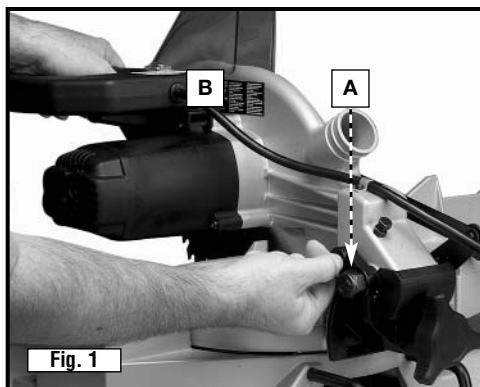

MOVING TABLE TO THE 0° CUT-OFF POSITION

1. Rotate the locking knob (A) Fig. 3 counter-clockwise. Lift the lever (B) and rotate the table (C) to the 0° straight cut-off position, release the lever (B), and tighten the locking knob (A).
2. For proper operation and adjustment of the table, refer to sections, **“ROTATING TABLE FOR MITER CUTTING”**, and **“ADJUSTING SLIDING FIT BETWEEN MOVABLE TABLE AND BASE.”**

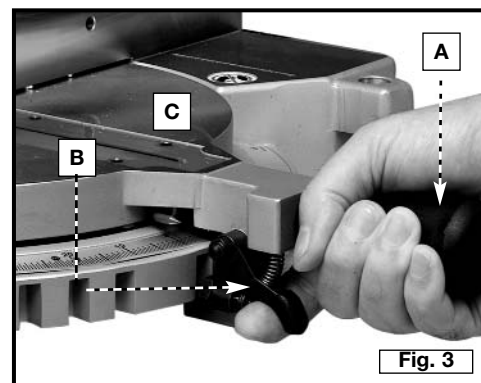

ATTACHING EXTENSION TABLE AND FENCE SLIDE

1. Thread the two M8 x 1.25 x 20 Hex Head Screw into the holes (A) Fig. 4 on the left side of the saw.

NOTE: Loosely tighten the hardware for further adjustment.

2. Attach the table extension (B) Figs. 4 and 5 to left side of saw table, making sure that the groove of the table extension (B) is inside the flat washers (C) Fig. 4.
3. Use a straight edge (A) Fig. 6 to ensure that the extension table (B) is even with the saw table (D). Tighten the two screws (C) Fig. 5.
4. Attach the fence slide support (E) Fig. 7 to the extension table (B) by using the two M8 x 1.25 x 30 socket head screws (F). Insert the two screws up through the two holes (G) in the table extension and thread them into the two threaded holes (H) on the bottom of the fence slide support.

NOTE: Loosely tighten the hardware for further adjustment.

5. Use a straight edge to align the fence slide support with the saw fence, and tighten the two screws.
6. Position the fence slide (K) Fig. 8 in the valley on the top of the saw fence (J) and the fence slide support (E). Move the fence slide (K) back and forth several times to check the alignment of the fence slide support (E). Make any necessary final adjustments to the fence slide support.
7. Use the 3mm hex wrench (A) Fig. 9 to thread the M6 x 1.0 x 16 set screw (B) in the fence slide support (C) to secure the extension fence.
8. Thread the fence clamping screw (N) Fig. 10 into the fence extension (E) to hold the fence extension in place.

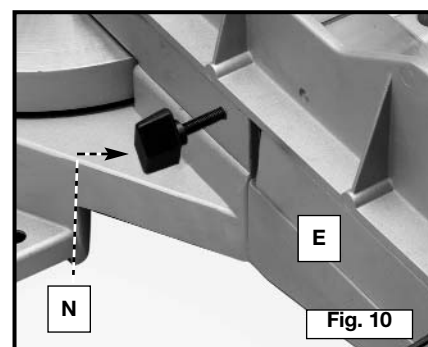
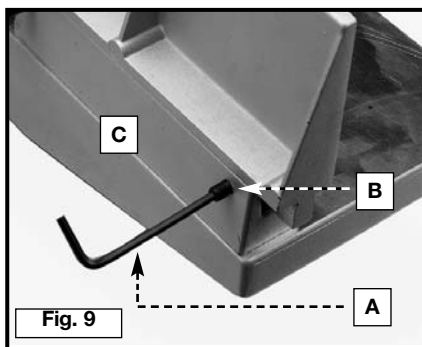
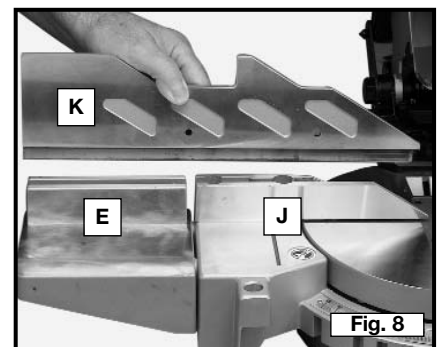
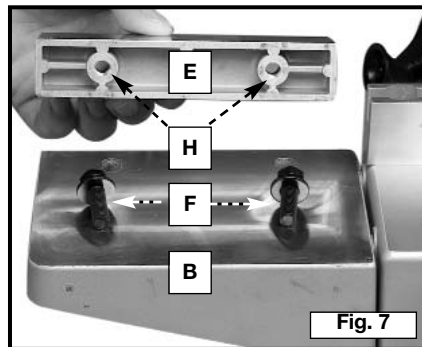
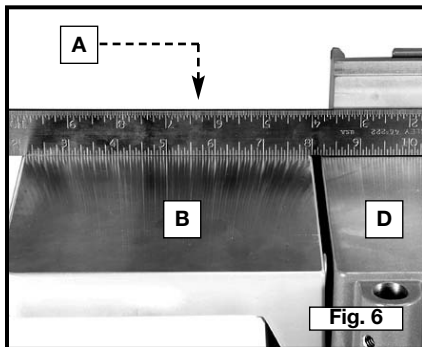
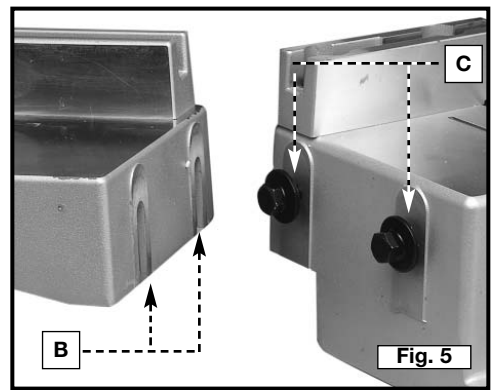
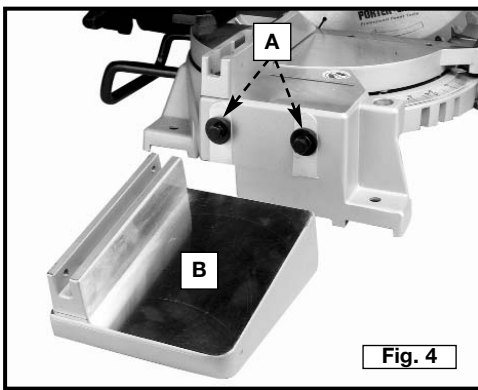

ATTACHING THE DUST BAG

Depress the spring clips (A) Fig. 11 of the dust bag (B) and clip the dust bag (B) over the ribs of the dust chute.

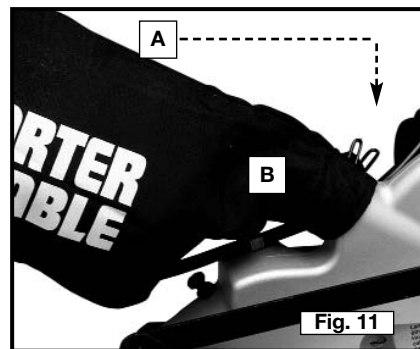

OPERATION

OPERATING CONTROLS AND ADJUSTMENTS

FASTENING MACHINE TO SUPPORTING SURFACE

Before operating your miter saw, firmly mount it to a workbench or other supporting surface. Four holes (A) Fig. 12 are provided for fastening the saw to a supporting surface.

When frequently moving the saw from place to place, mount the saw on a 3/4" piece of plywood. The saw can then be easily moved from place to place and the plywood can be clamped to the supporting surface using "C" clamps.

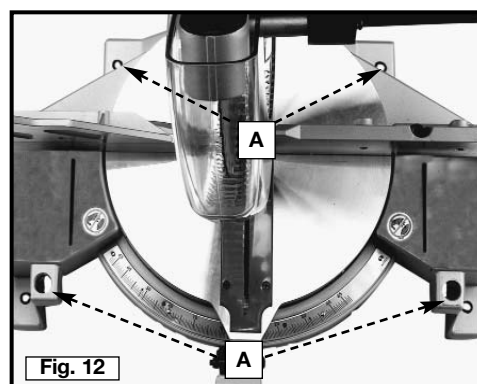

STARTING AND STOPPING MACHINE

To start the machine, depress the switch trigger (A) Fig. 13. To stop the machine, release the switch trigger.

This saw is equipped with an automatic electric blade brake. As soon as the switch trigger (A) Fig. 13 is released, the electric brake is activated and stops the blade in seconds.

⚠ WARNING A rotating saw blade can be dangerous. After completing the cut, release the switch trigger (A) Fig. 13 to activate the blade brake. Keep the cuttinghead down until the blade has come to a complete stop.

⚠ WARNING The torque developed during braking may loosen the arbor screw. The arbor screw should be checked periodically and tightened if necessary.

LOCKING SWITCH IN THE "OFF" POSITION

IMPORTANT: When the miter saw is not in use, the switch should be locked in the "OFF" position, using a padlock (B) Fig. 14 with a 3/16" diameter shackle to prevent unauthorized use of the saw.

In the event of a power outage, always lock switch in "OFF" position until the main power is restored.

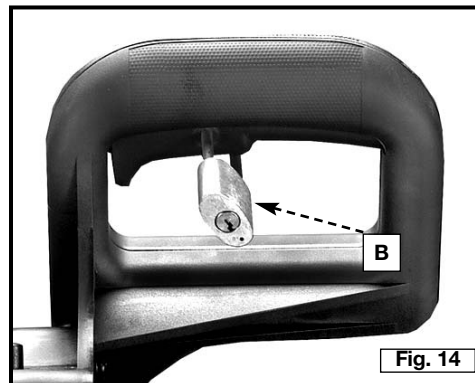
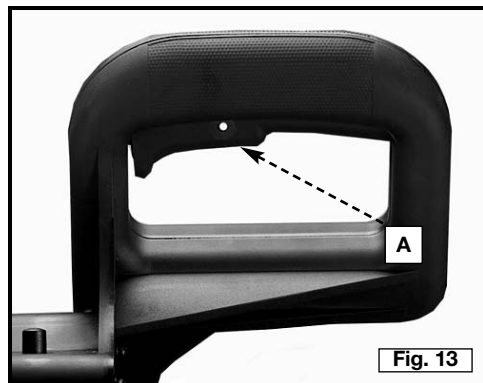

ROTATING THE TABLE FOR MITER CUTTING

1. This miter saw will cut any angle from 0° to 47° right and left. Turn the locking knob (A) Fig. 15 counter-clockwise, lift the miter detent trigger (B), and rotate the table.
2. The compound miter saw is equipped with positive stops at 0°, 15°, 22.5°, 30°, and 45° left and right.
3. The pointer (C) Fig. 16 indicates the actual angle of cut. Each scale line (B) represents 1°. When the center line (C) is moved from one line to the next on the scale, the angle of the cut is changed by 1°.

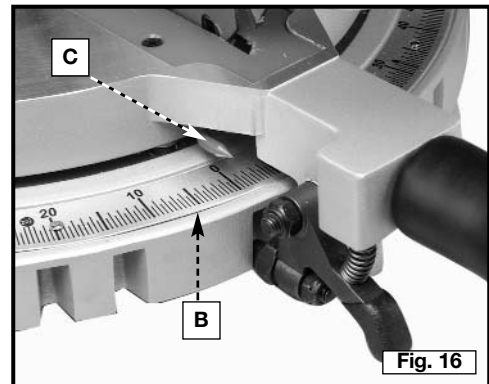
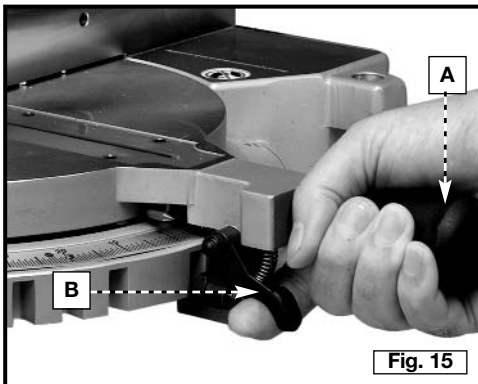

ADJUSTING THE SLIDING FIT BETWEEN THE MOVABLE TABLE AND THE BASE

⚠ WARNING DISCONNECT THE MACHINE FROM THE POWER SOURCE.

To adjust the sliding fit between the movable table and the base, turn the nut (A) Fig. 17 clockwise to increase the sliding fit (opposite to decrease the fit). This adjustment should not be so tight that it restricts the rotating movement of the table, or so loose that it affects the accuracy of the saw.

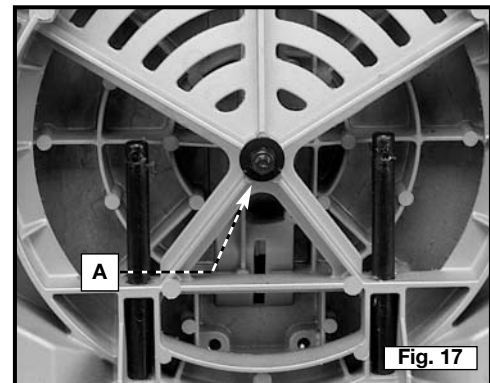

ADJUSTING THE FENCE 90° TO THE BLADE

IMPORTANT: Before making this adjustment, set the blade at 0° to the table. See section “ADJUSTING 0° AND 45° BEVEL POSITIVE STOPS.”

⚠ WARNING DISCONNECT THE MACHINE FROM THE POWER SOURCE.

1. Rotate the movable table so that the blade is 90° to the fence and the positive stop is set for 0°.
2. Place one end of a square (A) Fig. 18 against the front of the fence (B) (located under the motor), and the other end against the blade, with the blade locked in the down position. The fence should be 90° to the blade.
3. To adjust the fence (B) Fig. 18, use the supplied wrench to loosen the two screws (C) that attach the fence to the base. Adjust the fence (B), and tighten the screws (C).
4. Check the opposite fence (D) Fig. 19. To adjust, remove the extension fence, loosen the two screws (E), adjust the fence (D), and tighten the screws (G).

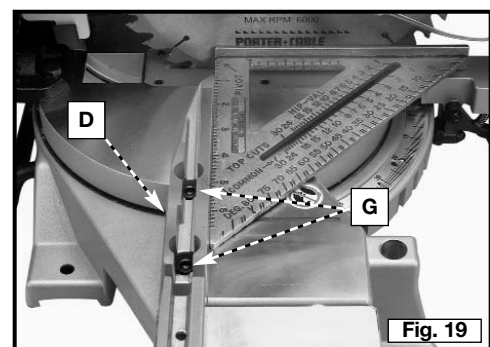
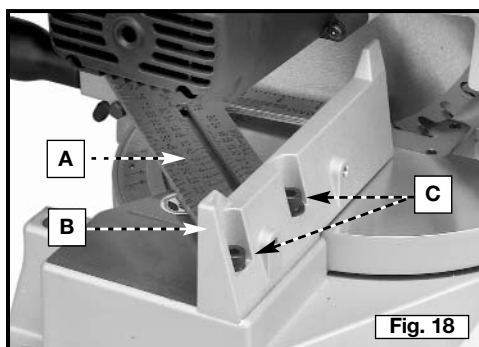
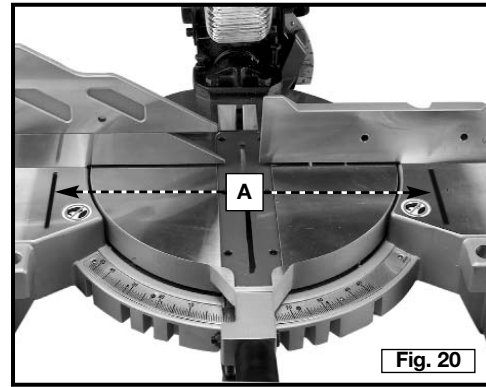

TABLE HAZARD ZONE

⚠ WARNING The area inside the two red lines (A) Fig. 20 on the table is designated as a HAZARD ZONE. Never place your hands inside this area while the tool is being operated. Always use a clamp to secure short workpieces.



TILTING CUTTINGHEAD FOR BEVEL CUTTING

⚠ WARNING DISCONNECT THE MACHINE FROM THE POWER SOURCE.

IMPORTANT: Move the sliding fence to provide clearance for the blade and guard. The degree of tilt determines how far to move the sliding fence. Refer to the section “**ADJUSTING SLIDING FENCE.**”

1. The cuttinghead can be tilted to cut any bevel angle from 90° to 45° left bevel. Loosen the bevel lock handle (A) Fig. 21, tilt the cuttinghead (B) to the desired angle, and tighten the lock handle (A).
2. Positive stops are provided to rapidly position the saw blade at 90° and 45°. Refer to the section of this manual titled “**ADJUSTING 90° AND 45° BEVEL POSITIVE STOPS.**” The bevel angle of the cutting arm is determined by the position of the pointer (C) Fig. 22 on scale (D).
3. In addition, a marked indicator (E) Fig. 22 is provided on the bevel scale (33.9°) for cutting crown moulding. Refer to the “**CUTTING CROWN MOULDING**” section of this manual.

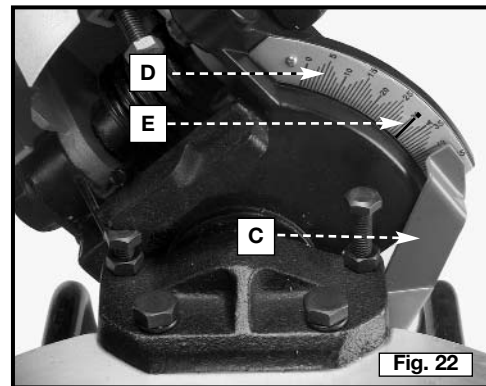
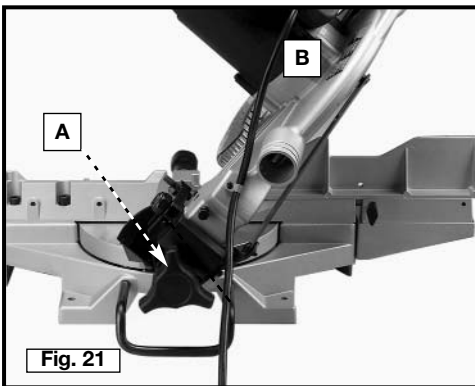

ADJUSTING SLIDING FENCE

The sliding fence (A) Fig. 23 provides support for extra large workpieces used with your saw. Set it as close as possible to the saw blade. When miter cutting (blade 90° to the table and at an angle to the right or left), set the fence all the way toward the blade (Fig. 23). When bevel cutting, however (blade tilted at an angle to the table), move the fence (A) Fig. 24 far enough away from the blade to allow for proper clearance. To reposition the fence, loosen the lock handle (B), and slide the fence (A) to the desired location. Tighten the lock handle (B).

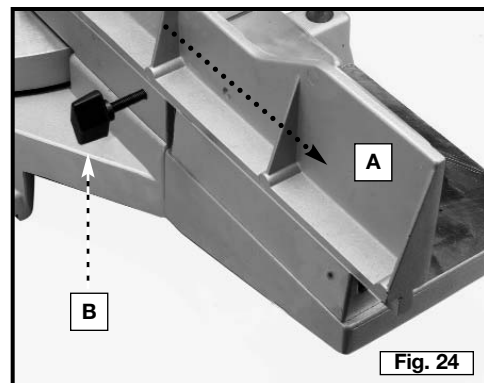
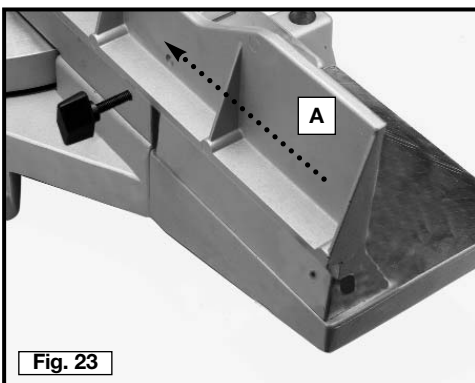

ADJUSTING 0° AND 45° BEVEL POSITIVE STOPS

⚠ WARNING DISCONNECT THE MACHINE FROM THE POWER SOURCE.

1. Adjust the saw so that both the bevel and miter pointers are set at 0°. Tighten the bevel lock handle (A) Fig. 25 and lock the cuttinghead in the down position.
2. Place one end of a square (A) Fig. 25 on the table and the other end against the blade. The blade should be 90° to the table.
3. To adjust, loosen the bevel lock handle. Loosen the locknut (B) Fig. 26 and turn the adjusting screw (C) with the provided wrenches until the blade is 90° to the table. Tighten the locknut (B) and the bevel lock handle (H).
4. When the blade is 90° to the table, adjust the pointer to line up with the 0° mark on the bevel scale.
5. Loosen the bevel lock handle, and move the cuttinghead all the way to the left bevel position and tighten the bevel lock handle.
6. Use a square (A) Fig. 27 to see if the blade is at 45° to the table.
7. To adjust, loosen the bevel lock handle. Loosen the locknut (E) Fig. 28 and turn the adjusting screw (F) with the provided wrench, until the blade is 45° to the table. Tighten the locknut (E) and the bevel lock handle.

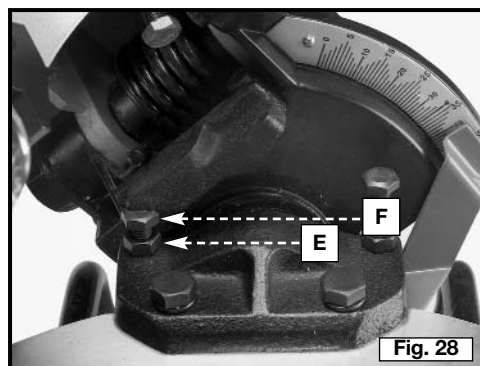
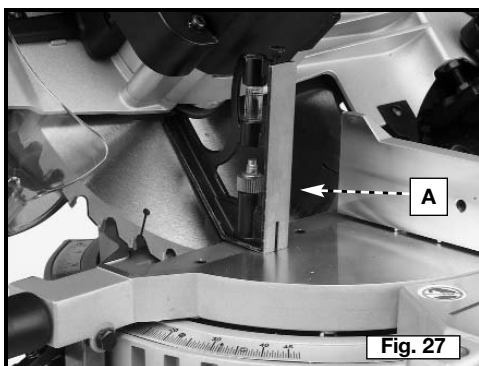
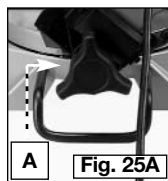
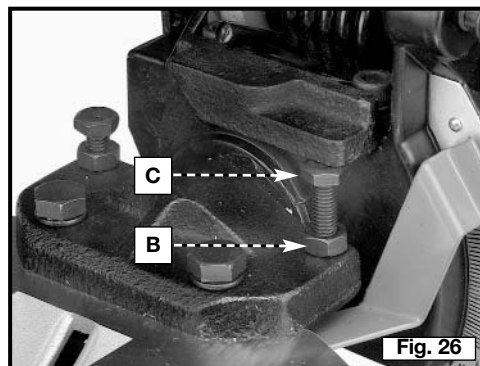

ADJUSTING THE TENSION OF CUTTINGHEAD RETURN SPRING

The cuttinghead return spring tension was adjusted at the factory to make the cuttinghead return to the "up" position after a cut is made. To adjust the spring tension, turn the adjusting screw (A) Fig. 29 clockwise to increase or counterclockwise to decrease the spring tension.

ADJUSTING SLIDING FIT BETWEEN CUTTINGHEAD ARM AND TRUNNION

After a long period of time, an adjustment of the sliding fit between the cuttinghead arm (B) Fig. 30, and the trunnion (C) may be necessary. To adjust, tighten the nut (D). This adjustment should not be so tight that it restricts the sliding movement of the cuttinghead arm (B) or so loose that it affects the accuracy of the saw cut.

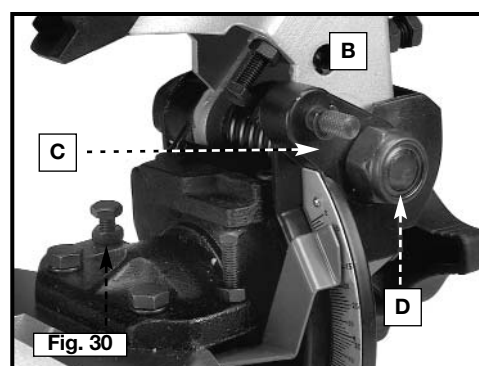
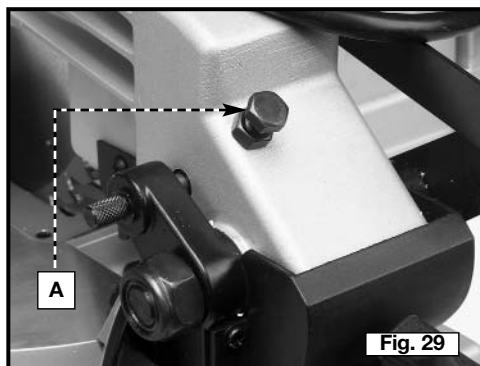

ADJUSTING DOWNWARD TRAVEL OF SAW BLADE

⚠ WARNING DISCONNECT THE MACHINE FROM THE POWER SOURCE.

1. The downward travel of the saw blade can be limited to prevent the saw blade from contacting any metal surfaces of the machine. Make this adjustment by loosening the locknut (A) Fig. 31, and turning the adjusting screw (B) in or out until other end of the screw (B) contacts the stop at the full downward travel of the saw blade.
2. Lower the blade as far as possible. Rotate the blade by hand to make certain that the teeth do not contact any metal surfaces. After adjusting, tighten the locknut (A) Fig. 31.

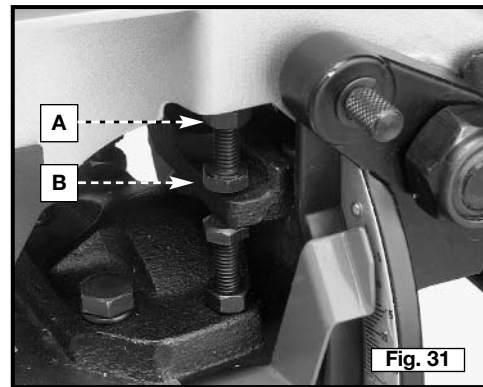

LASER USE AND ADJUSTMENT

The TwinLaser™ laser units are mounted in a housing that is fitted into the upper blade guard of the miter saw (Fig. A). The lasers project a beam of light downward, along both sides and parallel to the saw blade. This beam of light produces a line-of-cut indicator (a red outline of where the saw blade will cut) on the workpiece.

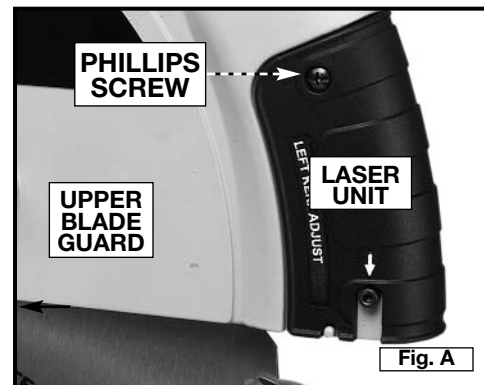

ADJUSTING THE TwinLaser™ LINES

Each of the laser lines have been aligned parallel to the blade at the factory and should not need any adjustment prior to use. However, left-to-right adjustment to the laser lines may be necessary if you change to a thicker or thinner kerf blade. For information on changing your blade, refer to the "**MAINTENANCE: CHANGING THE BLADE**" section of this manual. To adjust the laser lines to the edge of the cut, follow the instructions below.

HOW THE LASERS WORK

The laser units are mounted in a housing that is fitted into the upper blade guard of the miter saw (Fig. A). The laser units are aligned to the original equipment blade at the factory and are secured in place. A test cut has been made with each saw to verify laser setup. If your saw becomes misaligned or you desire additional precision, this guide is intended to assist you in fine tuning your laser miter saw.

HOW TO CHECK LASER ALIGNMENT

Make sure the saw is set to 0 degrees, miter and bevel, and clamp a 2"x 6" board on the saw. Create a partial test cut in the workpiece (Fig. C). Turn the laser "ON/OFF" switch (Fig. B) to the "ON" position. Leave the workpiece clamped in place for the remainder of the adjustment.

⚠ CAUTION  Observe the laser CAUTION label (L) Fig. B.

⚠ WARNING Place a padlock (A) Fig. B (with 3/16" shackle) through the hole in the trigger switch and lock to prevent accidental motor startup. This padlock **MUST** remain in place during the adjustment procedure.

The laser lines are properly positioned when the beams of light fall on the edge of the cut created by the blade (Fig. D).

NOTE: The “ON-OFF” switch for the laser beam is spring-loaded for longer battery life and is located on the handle at (A) Fig. B1.

NOTE: The laser beam is powered by 3 AA batteries (not supplied), located at (B) Fig. B1. Use a Phillips screwdriver to remove the screw of the cover and insert the batteries.

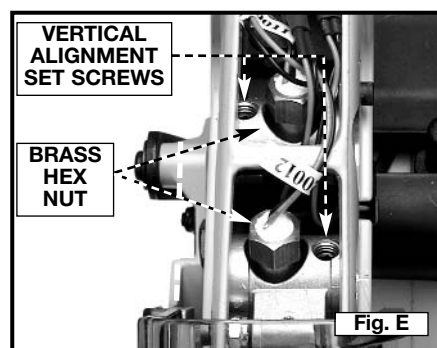
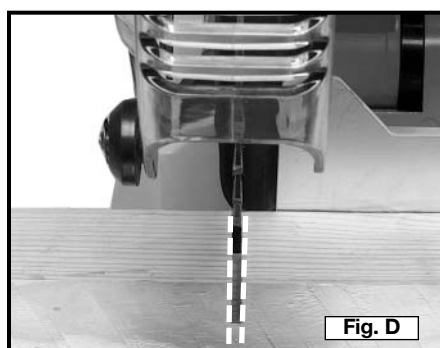
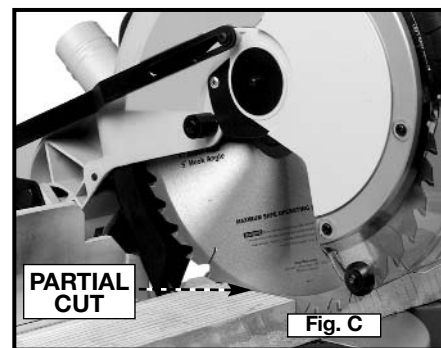
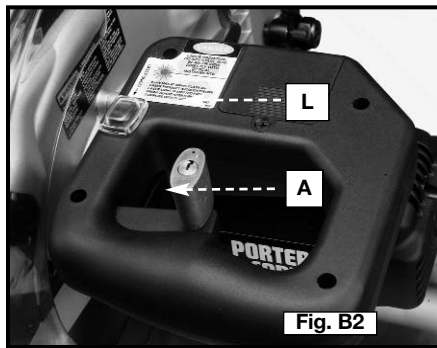
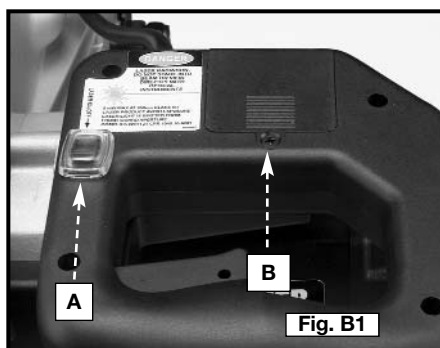

TO CHECK FOR ROTATIONAL ALIGNMENT

The rotation of the lines is set parallel at the factory and permanently secured. No user adjustment is available for the rotational alignment. Never twist the brass hex nuts in Fig. E.

TO CHECK FOR VERTICAL ALIGNMENT

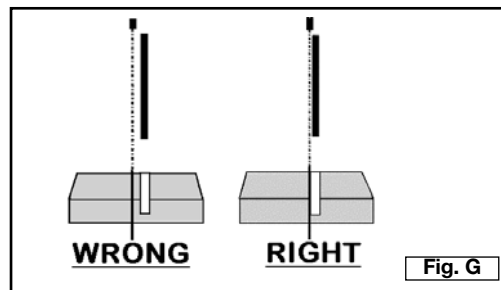
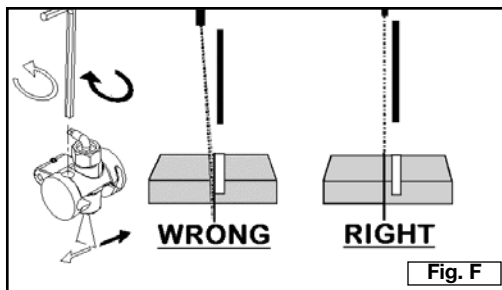

1. The vertical alignment is set correctly when the lines do not move horizontally (sideways) as the saw head is raised and lowered. If vertical alignment is correct, go to **“TO SET LEFT AND RIGHT KERF ADJUSTMENT”**.
2. To adjust, turn the left and right kerf adjustment screws one half turn clockwise. Take off the laser unit cover by removing the phillips screw on either side of the cover. (Fig. A).
3. Use the 1/8" hex wrench to turn the left or right vertical alignment set screws. If, as the saw head goes from a raised to a lowered position, the laser line moves horizontally away from the blade, turn the vertical alignment set screw clockwise to correct. If the laser line moves horizontally towards the blade, turn the vertical alignment set screw counter-clockwise. (Fig. F)
4. Reinstall the cover removed in **STEP 1**, and continue to **“TO SET LEFT AND RIGHT KERF ADJUSTMENT”**.

TO SET LEFT and RIGHT KERF ADJUSTMENT

1. Use the 1/8" hex wrench to turn the left or right kerf adjustment screws and set the laser lines to either side of the test cut (Fig. G). To adjust the left line, turn the left kerf adjustment screw counter-clockwise to move the line toward the blade and clockwise to move the line away from the blade. To adjust the right line turn the right kerf adjustment screw counter-clockwise to move the line toward the blade and clockwise to move the line away from the blade. (Fig. H)

CAUTION  **Observe the laser CAUTION label (L) Fig. H.**

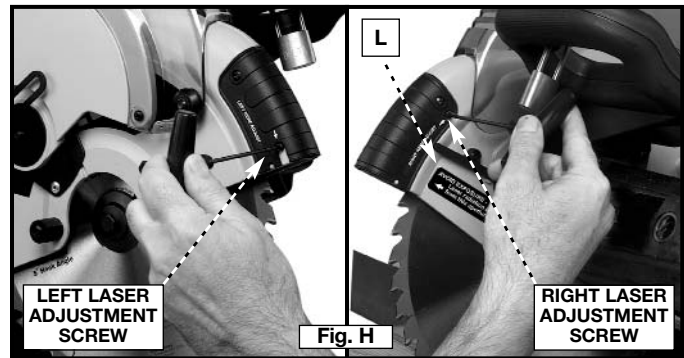

2. Remove the padlock and use the saw normally.

TwinLaser™ MAINTENANCE

For best laser performance, perform the following maintenance regularly:

WARNING **DISCONNECT THE MACHINE FROM THE POWER SOURCE.**

1. Carefully clean sawdust from each laser lens (A) Fig. J with a cotton swab (B). Do not use solvents of any kind since they may damage the lens. Avoid touching sharp points of the saw blade with your hands or fingers. Dust build-up can block the laser and prevent it from accurately indicating the line-of-cut.
2. Remove the blade from the saw and clean pitch build-up from the blade (Fig. K) Pitch build-up can block the laser and prevent it from accurately indicating the line-of-cut.

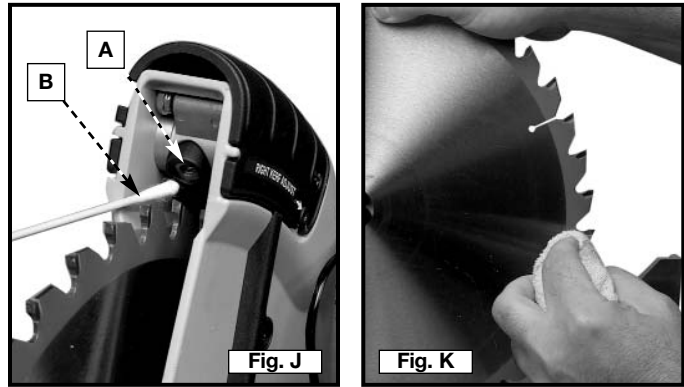

ADJUSTING LOWER BLADE GUARD

After an extended period of use, the movable lower blade guard (A) Fig. 32 may not operate smoothly when the cuttinghead is lowered. You can correct this by adjusting the nut (B) until the lower blade guard (A) moves freely.

WARNING **Do not over-tighten the nut as this can make the guard hard to move.**

MACHINE USE

TYPICAL OPERATIONS AND HELPFUL HINTS

1. Before cutting, make certain the cutting arm and table are at their correct settings and firmly locked in place.
2. Place the workpiece on the table and hold or clamp it firmly against the fence. Fig. 33 illustrates the work clamp (A). The clamp (A) can also be used on the right side of the machine.
3. **WARNING** **If the position or size of the workpiece causes your hand to be in the "Hazard Zone", use the work clamp to secure the workpiece. Keep your hands out of the "Hazard Zone".**
4. For best results, cut at a slow, even cutting rate.
5. Never attempt freehand cutting (wood that is not held firmly against the fence and table).

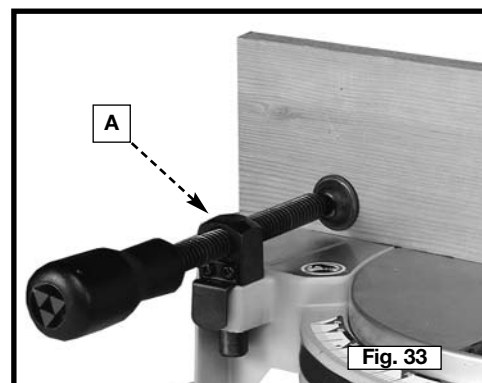
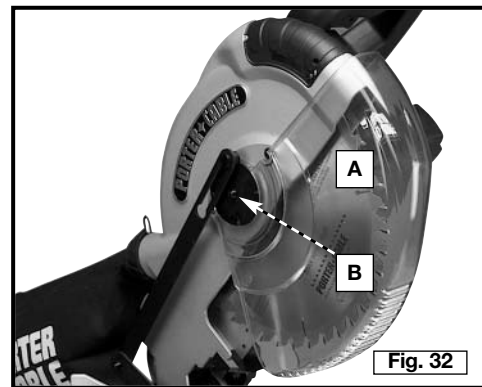

AUXILIARY WOOD FENCE

⚠ WARNING When performing multiple or repetitive operations that result in small cut-off pieces (one inch or less), the saw blade can catch the cut-off pieces and project them out of the machine or into the blade guard and housing, causing damage or injury. To limit the risk, mount an auxiliary wood fence on your saw (Fig. 34).

Holes are provided in the fence to attach an auxiliary fence (A) Fig. 34. This auxiliary fence is constructed of straight wood approximately 1/2" thick by 3" high by 20" long. **NOTE:** The auxiliary fence (A) is used **ONLY** with the saw blade in the 0 degree bevel position (90 degrees to the table). When bevel cutting (blade tilted), remove the auxiliary fence.

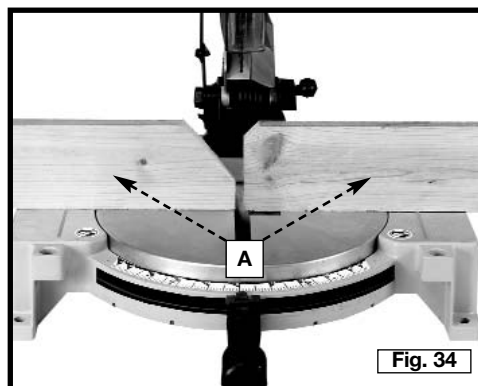

GENERAL CUTTING OPERATIONS

1. Your machine has the capacity to cut standard 2 x 4's lying flat or on edge, at the 45 degree right and left miter angles (Figs. A1 and A2).
2. A standard 2 x 6 can be cut in the 90 degree straight cut-off position in one pass (Fig. A3).
3. Cutting a standard 4 x 4 can be accomplished with one pass (Fig. A4).
4. This machine has the capacity to accurately cut crown mouldings and other bevel-type cuts (Fig. A5).
5. Cutting various sizes of plastic pipe is an easy job with this machine (Fig. A6).

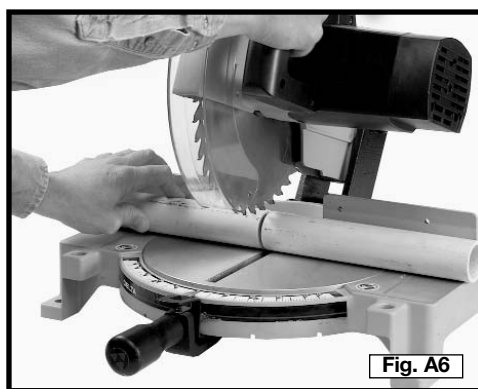
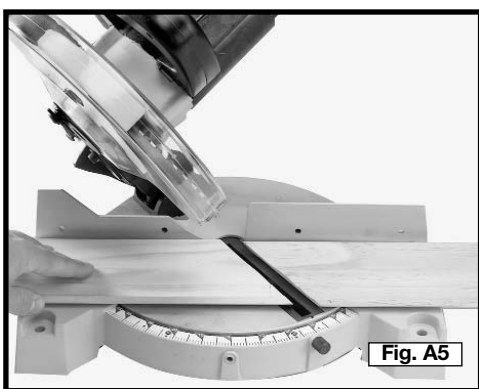
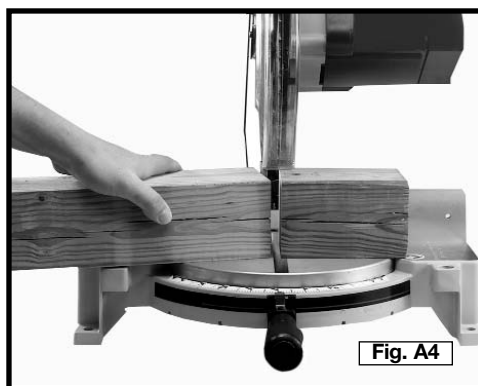
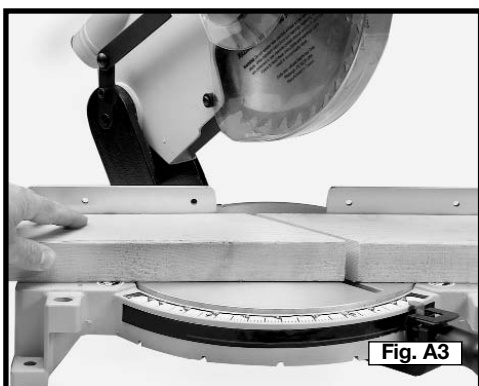
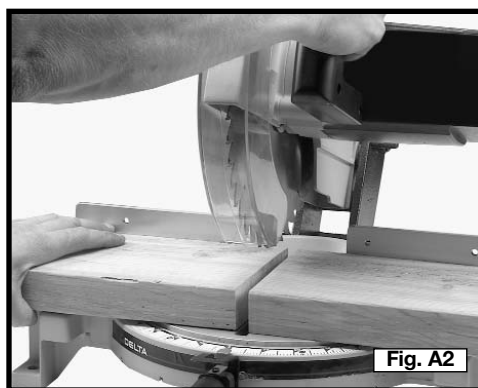
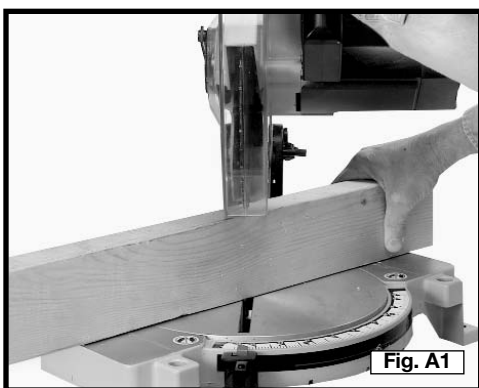

CUTTING ALUMINUM

Aluminum extrusions such as used for making aluminum screens and storm windows can easily be cut with your compound miter saw. When cutting aluminum extrusions, or other sections that can be cut with a saw blade and are within the capacity of the machine, position the material so the blade is cutting through the smallest cross-section (Fig. 35). The wrong way to cut aluminum angles is illustrated in Fig. 36. Be sure to apply a stick wax to the blade before cutting aluminum stock. This stick wax is available at most industrial mill supply houses. The wax provides proper lubrication and keeps chips from adhering to the blade.

⚠ WARNING NEVER APPLY LUBRICANT TO THE BLADE WHILE THE MACHINE IS RUNNING.

CUTTING BOWED MATERIAL

When cutting flat pieces, first check to see if the material is bowed. If it is, make sure the material is positioned on the table as shown in Fig. 37.

If the material is positioned the wrong way, as shown in Fig. 38, the workpiece will pinch the blade near the completion of the cut.

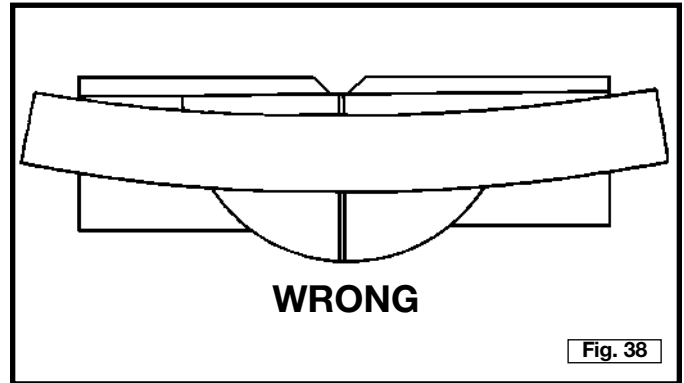
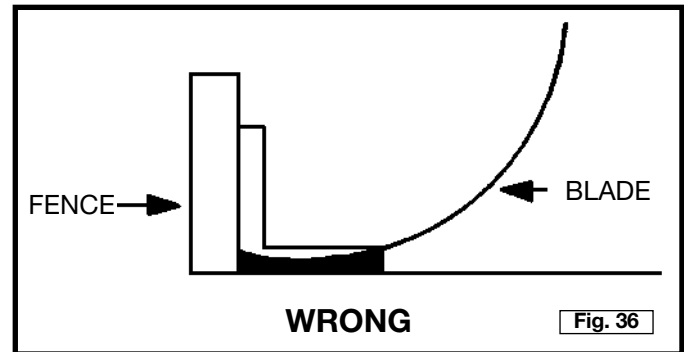
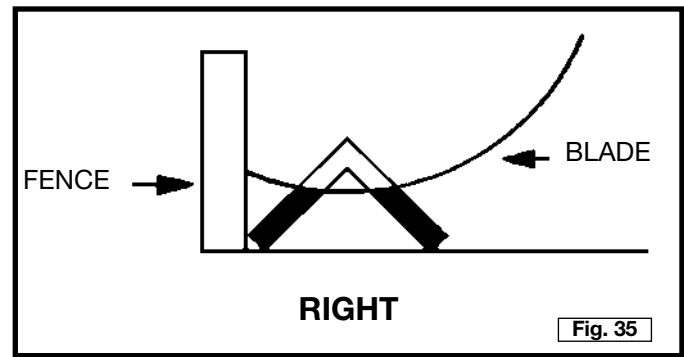
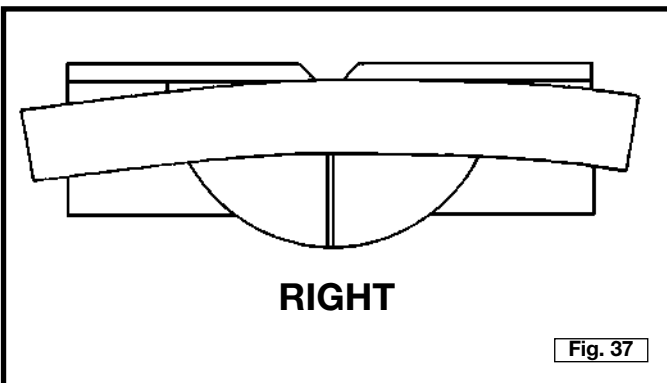

WORK SUPPORT EXTENSIONS

For support when cutting long pieces, construct a work support extension. Fig. 39 illustrates the miter saw mounted on two standard 2 x 4's (A). Fasten the four mounting legs (two of which are shown at (B) Fig. 39) to the 2 x 4's, using four screws (not supplied) through the four holes in the mounting legs. The length of the 2 x 4's (A) can vary, depending on the workpiece.

NOTE: Ensure that the top of the support 2 x 4's (C) are level with the miter saw table. This is critical because the distance from the top of the 2 x 4's (A) to the miter saw table varies from saw to saw. In most cases, standard 2 x 4's (C) can be used. If these are too high, cut them to fit. If the 2 x 4's are too low, use 2 x 6's. If these are high, cut them to the correct height.

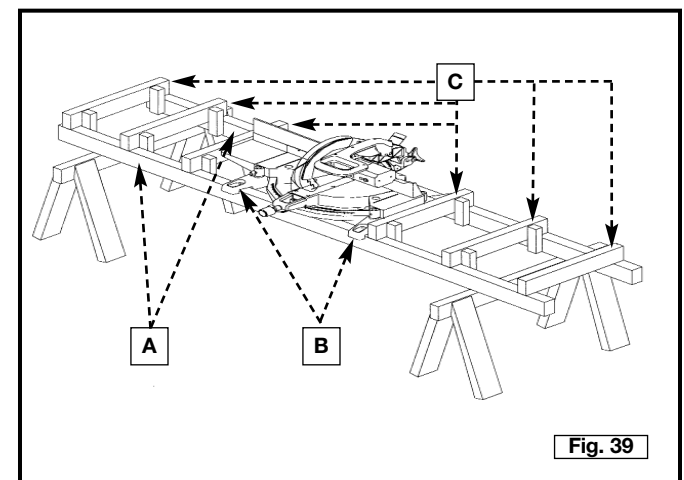

CUTTING CROWN MOULDING

One of the many features of the saw is the ease of cutting crown moulding. The following is an example of cutting both inside and outside corners on **52°/38°** wall angle crown moulding.

1. Move the table to the 31.62° right miter position and lock the table in position. **NOTE:** A positive stop is provided to find this angle quickly.
2. Tilt the saw blade to the 33.86° left bevel position and tighten bevel lock handle. **NOTE:** A triangle indicator is provided on the bevel scale to find this angle quickly.
3. Place the crown moulding on the table with the **CEILING EDGE** of the moulding against the fence, and make the cut, as shown in Fig. 40.

NOTE: The piece of crown moulding used for the outside corner will always be on the right hand side of the blade, as shown at (A) Fig. 40. The piece of crown moulding used for the inside corner will always be on the left hand side of the blade, as shown at (B) Fig. 40.

4. To make the matching halves of the inside and outside corners, rotate the table to the 31.62° left miter position.

NOTE: A positive stop is provided to find this angle quickly. The saw blade is already tilted to the 33.86° bevel position from the previous cut.

5. Place the crown moulding on the table with the **WALL EDGE** of the crown moulding against the fence and make the cut. Again, the piece of crown moulding used for the outside corner will always be on the right side of the blade, as shown at (C) Fig. 41. The piece of crown moulding used for the inside corner will always be on the left side of the blade, as shown at (D) Fig. 41.

6. Fig. 42 illustrates the two outside corner pieces; (1) being the piece cut at (A) Fig. 40 and (2) being the piece cut at (C) Fig. 41.

7. Fig. 43 illustrates the two inside corner pieces; (1) being the piece cut at (B) Fig. 40, and (2) being the piece cut at (D) Fig. 41.

45-45 CROWN MOULDING

NOTE: If you are cutting crown moulding that is **45°-45°**, follow the same procedure above, with the exception that the bevel position will always be at 30° and the miter position will be 35-1/4° to the right or left.

OTHER ANGLES

NOTE: The above instructions are assuming the angle between the walls is 90°. If you need help cutting crown moulding for walls set at angles other than 90°, see the instruction sheet **“CUTTING CROWN MOULDING”** on the Delta Machinery web site at www.deltamachinery.com.

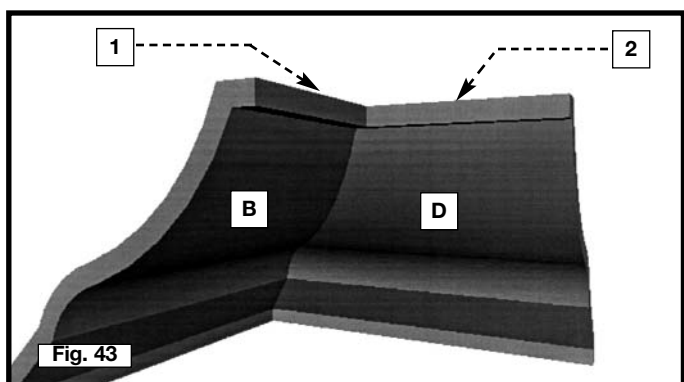
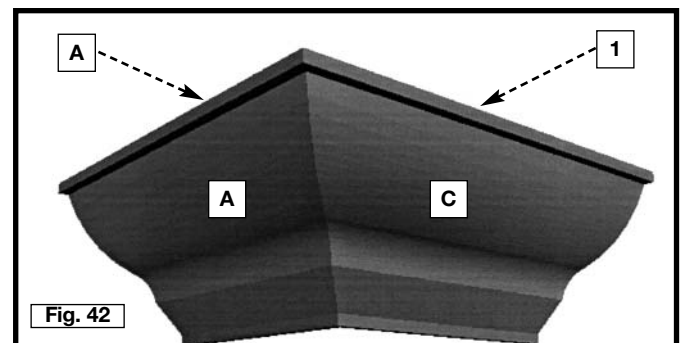
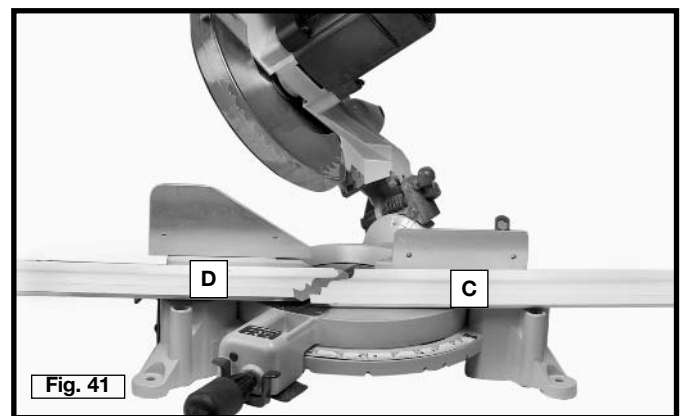
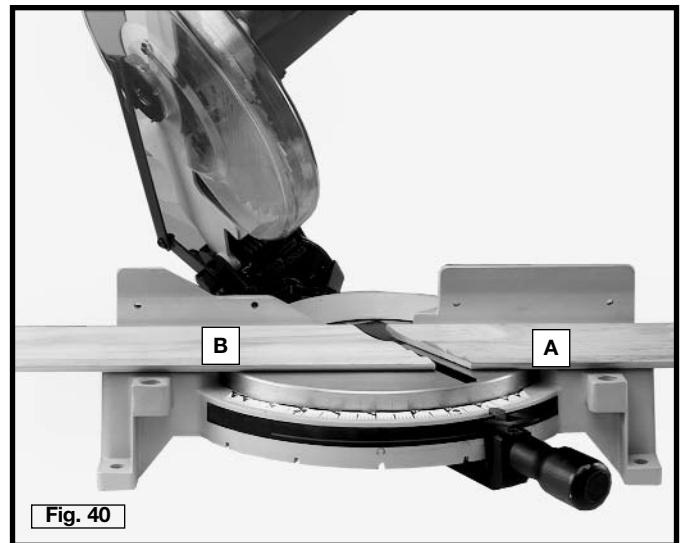

TROUBLESHOOTING

For assistance with your tool, visit our website at www.porter-cable.com for a list of service centers or call the Porter-Cable help line at 1-800-487-8665.

MAINTENANCE

CHANGING THE BLADE

⚠ WARNING Use only cross-cutting saw blades.

⚠ WARNING When using carbide-tipped blades, do not use blades with deep gullets as they can deflect and contact the guard.

⚠ WARNING Use only 10" diameter saw blades that are rated for 5200 RPM or higher and have 5/8" diameter arbor holes.

⚠ WARNING **DISCONNECT MACHINE FROM POWER SOURCE.**

1. Remove the screw (A) Fig. 44 and rotate the cover (B) to the rear (Fig. 45).
2. To remove the saw blade, insert the supplied hex wrench (C) Fig. 46 into the hex hole located on the rear end of the motor shaft to keep the shaft from turning.
3. Use a wrench (G) Fig. 47 to loosen arbor screw (E) by turning it clockwise.
4. Remove arbor screw (E) Fig. 47, outside blade flange (F), and saw blade from saw arbor.
5. Attach new saw blade **MAKING CERTAIN TEETH OF SAW BLADE ARE POINTING DOWN AT THE FRONT.** Re-attach outside blade flange (F) Fig. 47, and arbor screw (E) by turning it counterclockwise using wrench (G) Fig. 47. At the same time, use hex wrench (C) Fig. 46 to keep the arbor from turning.
6. Replace screw and cover that was rotated to the rear in **STEP 1.**

⚠ WARNING Remove the wrenches (C) FIG. 46 AND (G) FIG. 47 before starting the machine.

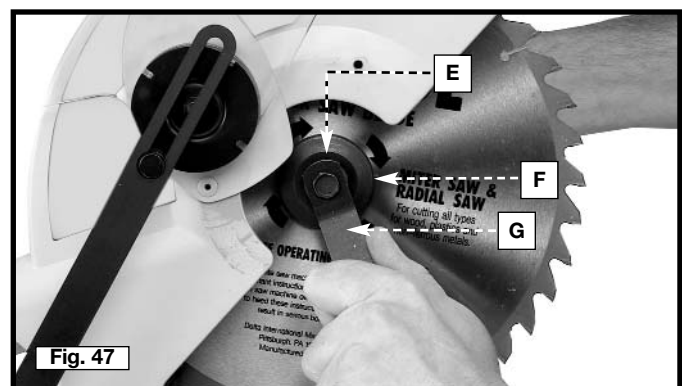
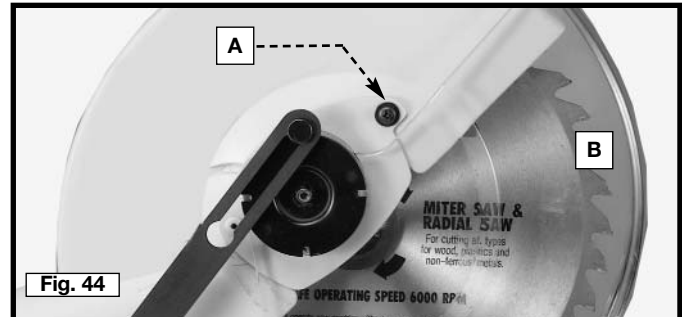

KEEP TOOL CLEAN

Periodically blow out all air passages with dry compressed air. All plastic parts should be cleaned with a soft damp cloth. NEVER use solvents to clean plastic parts. They could possibly dissolve or otherwise damage the material.

▲WARNING Wear ANSI Z87.1 safety glasses while using compressed air.

FAILURE TO START

Should your tool fail to start, check to make sure the prongs on the cord plug are making good contact in the outlet. Also, check for blown fuses or open circuit breakers in the line.

LUBRICATION

This tool has been lubricated with a sufficient amount of high grade lubricant for the life of the unit under normal operating conditions. No further lubrication is necessary.

BRUSH INSPECTION (If applicable)

For your continued safety and electrical protection, brush inspection and replacement on this tool should ONLY be performed by an AUTHORIZED PORTER-CABLE SERVICE STATION or a PORTER-CABLE•DELTA FACTORY SERVICE CENTER.

At approximately 100 hours of use, take or send your tool to your nearest authorized Porter-Cable Service Station to be thoroughly cleaned and inspected. Have worn parts replaced and lubricated with fresh lubricant. Have new brushes installed, and test the tool for performance.

Any loss of power before the above maintenance check may indicate the need for immediate servicing of your tool. DO NOT CONTINUE TO OPERATE TOOL UNDER THIS CONDITION. If proper operating voltage is present, return your tool to the service station for immediate service.

SERVICE

REPLACEMENT PARTS

When servicing use only identical replacement parts.

SERVICE AND REPAIRS

All quality tools will eventually require servicing or replacement of parts due to wear from normal use. These operations, including brush inspection and replacement, should ONLY be performed by either an AUTHORIZED PORTER-CABLE SERVICE STATION or a PORTER-CABLE-DELTA FACTORY SERVICE CENTER. All repairs made by these agencies are fully guaranteed against defective material and workmanship. We cannot guarantee repairs made or attempted by anyone other than these agencies.

Should you have any questions about your tool, feel free to write us at any time. In any communications, please give all information shown on the nameplate of your tool (model number, type, serial number, etc.).

ACCESSORIES

A complete line of accessories is available from your Porter-Cable-Delta Supplier, Porter-Cable-Delta Factory Service Centers, and Porter-Cable Authorized Service Stations. Please visit our Web Site www.porter-cable.com for a catalog or for the name of your nearest supplier.

▲WARNING

Since accessories other than those offered by Porter-Cable-Delta have not been tested with this product, use of such accessories could be hazardous. For safest operation, only Porter-Cable-Delta recommended accessories should be used with this product.

WARRANTY

PORTER-CABLE LIMITED ONE YEAR WARRANTY

Porter-Cable warrants its Professional Power Tools for a period of one year from the date of original purchase. We will repair or replace at our option, any part or parts of the product and accessories covered under this warranty which, after examination, proves to be defective in workmanship or material during the warranty period. For repair or replacement return the complete tool or accessory, transportation prepaid, to your nearest Porter-Cable Service Center or Authorized Service Station. Proof of purchase may be required. This warranty does not apply to repair or replacement required due to misuse, abuse, normal wear and tear or repairs attempted or made by other than our Service Centers or Authorized Service Stations.

ANY IMPLIED WARRANTY, INCLUDING THE IMPLIED WARRANTIES OF MERCHANTABILITY AND FITNESS FOR A PARTICULAR PURPOSE, WILL LAST ONLY FOR ONE (1) YEAR FROM THE DATE OF PURCHASE.

To obtain information on warranty performance please write to: PORTER-CABLE CORPORATION, 4825 Highway 45 North, Jackson, Tennessee 38305; Attention: Product Service. THE FOREGOING OBLIGATION IS PORTER-CABLE'S SOLE LIABILITY UNDER THIS OR ANY IMPLIED WARRANTY AND UNDER NO CIRCUMSTANCES SHALL PORTER-CABLE BE LIABLE FOR ANY INCIDENTAL OR CONSEQUENTIAL DAMAGES. Some states do not allow limitations on how long an implied warranty lasts or the exclusion or limitation of incidental or consequential damages, so the above limitation or exclusion may not apply to you.

This warranty gives you specific legal rights and you may also have other legal rights which vary from state to state.

PORTER-CABLE • DELTA SERVICE CENTERS (CENTROS DE SERVICIO DE PORTER-CABLE • DELTA)

Parts and Repair Service for Porter-Cable • Delta Machinery are Available at These Locations
(Obtenga Refaccion de Partes o Servicio para su Herramienta en los Siguietes Centros de Porter-Cable • Delta)

ARIZONA

Tempe 85282 (Phoenix)
2400 West Southern Avenue
Suite 105
Phone: (602) 437-1200
Fax: (602) 437-2200

CALIFORNIA

Ontario 91761 (Los Angeles)
3949A East Guasti Road
Phone: (909) 390-5555
Fax: (909) 390-5554

San Diego 92111
7638 Clairemnot Blvd.
Phone: (858) 277-9595
Fax: (858) 277-9696

San Leandro 94577 (Oakland)
3039 Teagarden Street
Phone: (510) 357-9762
Fax: (510) 357-7939

COLORADO

Arvada 80003 (Denver)
8175 Sheridan Blvd., Unit S
Phone: (303) 487-1809
Fax: (303) 487-1868

FLORIDA

Davie 33314 (Miami)
4343 South State Rd. 7 (441)
Unit #107
Phone: (954) 321-6635
Fax: (954) 321-6638

Tampa 33609
4538 W. Kennedy Boulevard
Phone: (813) 877-9585
Fax: (813) 289-7948

GEORGIA

Forest Park 30297 (Atlanta)
5442 Frontage Road,
Suite 112
Phone: (404) 608-0006
Fax: (404) 608-1123

ILLINOIS

Addison 60101 (Chicago)
400 South Rohlwing Rd.
Phone: (630) 424-8805
Fax: (630) 424-8895

Woodridge 60517 (Chicago)
2033 West 75th Street
Phone: (630) 910-9200
Fax: (630) 910-0360

MARYLAND

Elkridge 21075 (Baltimore)
7397-102 Washington Blvd.
Phone: (410) 799-9394
Fax: (410) 799-9398

MASSACHUSETTS

Franklin 02038 (Boston)
Franklin Industrial Park
101E Constitution Blvd.
Phone: (508) 520-8802
Fax: (508) 528-8089

MICHIGAN

Madison Heights 48071 (Detroit)
30475 Stephenson Highway
Phone: (248) 597-5000
Fax: (248) 597-5004

MINNESOTA

Minneapolis 55429
5522 Lakeland Avenue North
Phone: (763) 561-9080
Fax: (763) 561-0653

MISSOURI

North Kansas City 64116
1141 Swift Avenue
Phone: (816) 221-2070
Fax: (816) 221-2897

St. Louis 63119
7574 Watson Road
Phone: (314) 968-8950
Fax: (314) 968-2790

NEW YORK

Flushing 11365-1595 (N.Y.C.)
175-25 Horace Harding Expwy.
Phone: (718) 225-2040
Fax: (718) 423-9619

NORTH CAROLINA

Charlotte 28270
9129 Monroe Road, Suite 115
Phone: (704) 841-1176
Fax: (704) 708-4625

OHIO

Columbus 43214
4560 Indianola Avenue
Phone: (614) 263-0929
Fax: (614) 263-1238

Cleveland 44125
8001 Sweet Valley Drive
Unit #19
Phone: (216) 447-9030
Fax: (216) 447-3097

OREGON

Portland 97230
4916 NE 122 nd Ave.
Phone: (503) 252-0107
Fax: (503) 252-2123

PENNSYLVANIA

Willow Grove 19090
(Philadelphia)
520 North York Road
Phone: (215) 658-1430
Fax: (215) 658-1433

TEXAS

Carrollton 75006 (Dallas)
1300 Interstate 35 N, Suite 112
Phone: (972) 446-2996
Fax: (972) 446-8157

Houston 77043
4321 Sam Houston Parkway,
West
Suite 180
Phone: (713) 983-9910
Fax: (713) 983-6645

WASHINGTON

Auburn 98001(Seattle)
3320 West Valley HWY, North
Building D, Suite 111
Phone: (253) 333-8353
Fax: (253) 333-9613

Authorized Service Stations are located in many large cities. Telephone **800-438-2486** or **731-541-6042** for assistance locating one. Parts and accessories for Porter-Cable-Delta products should be obtained by contacting any Porter-Cable-Delta Distributor, Authorized Service Center, or Porter-Cable-Delta Factory Service Center. If you do not have access to any of these, call **800-223-7278** and you will be directed to the nearest Porter-Cable-Delta Factory Service Center. Las Estaciones de Servicio Autorizadas están ubicadas en muchas grandes ciudades. Llame al **800-438-2486** ó al **731-541-6042** para obtener asistencia a fin de localizar una. Las piezas y los accesorios para los productos Porter-Cable-Delta deben obtenerse poniéndose en contacto con cualquier distribuidor Porter-Cable-Delta, Centro de Servicio Autorizado o Centro de Servicio de Fábrica Porter-Cable-Delta. Si no tiene acceso a ninguna de estas opciones, llame al **800-223-7278** y le dirigirán al Centro de Servicio de Fábrica Porter-Cable-Delta más cercano.

CANADIAN PORTER-CABLE • DELTA SERVICE CENTERS

ALBERTA

Bay 6, 2520-23rd St. N.E.
Calgary, Alberta
T2E 8L2
Phone: (403) 735-6166
Fax: (403) 735-6144

BRITISH COLUMBIA

8520 Baxter Place
Burnaby, B.C.
V5A 4T8
Phone: (604) 420-0102
Fax: (604) 420-3522

MANITOBA

1699 Dublin Avenue
Winnipeg, Manitoba
R3H 0H2
Phone: (204) 633-9259
Fax: (204) 632-1976

ONTARIO

505 Southgate Drive
Guelph, Ontario
N1H 6M7
Phone: (519) 767-4132
Fax: (519) 767-4131

QUÉBEC

1515 ave.
St-Jean Baptiste, Suite 160
Québec, Québec
G2E 5E2
Phone: (418) 877-7112
Fax: (418) 877-7123

1447, Begin
St-Laurent, (Montréal),
Québec
H4R 1V8
Phone: (514) 336-8772
Fax: (514) 336-3505

The following are trademarks of PORTER-CABLE • DELTA (Las siguientes son marcas registradas de PORTER-CABLE • DELTA S.A.) (Les marques suivantes sont des marques de fabrication de la PORTER-CABLE • DELTA): Auto-Set®, BAMMER®, B.O.S.S.®, Builder's Saw®, Contractor's Saw II™, Delta®, DELTACRAFT®, DELTAGRAM™, Delta Series 2000™, DURATRONIC™, Emc2™, FLEX®, Flying Chips™, FRAME SAW®, Grip Vac™, Homecraft®, INNOVATION THAT WORKS®, Jet-Lock®, JETSTREAM®, 'kickstand®, LASERLOC®, MICRO-SET®, Micro-Set®, MIDI LATHE®, MORTEN™, NETWORK™, OMNIJIG®, POCKET CUTTER®, PORTA-BAND®, PORTA-PLANE®, PORTER-CABLE®&(design), PORTER-CABLE®PROFESSIONAL POWER TOOLS, PORTER-CABLE REDEFINING PERFORMANCE™, Posi-Matic®, Q-3®&(design), QUICKSAND®&(design), QUICKSET™, QUICKSET II®, QUICKSET PLUS™, RIPTIDE™&(design), SAFE GUARD II®, SAFE-LOC®, Sanding Center®, SANDTRAP®&(design), SAW BOSS®, Sawbuck™, Sidekick®, SPEED-BLOC®, SPEEDMATIC®, SPEEDTRONIC®, STAIR EASE®, The American Woodshop®&(design), The Lumber Company®&(design), THE PROFESSIONAL EDGE®, THE PROFESSIONAL SELECT®, THIN-LINE™, TIGER®, TIGER CUB®, TIGER SAW®, TORQBUSTER®, TORQ-BUSTER®, TRU-MATCH™, TWIN-LITE®, UNIGUARD®, Unifence®, UNIFEEDER™, Unihead®, Uniplane™, Unirip®, Unisaw®, Univise®, Versa-Feeder®, VERSA-PLANE®, WHISPER SERIES®, WOODWORKER'S CHOICE™.

Trademarks noted with ™ and ® are registered in the United States Patent and Trademark Office and may also be registered in other countries. Las Marcas Registradas con el signo de ™ y ® son registradas por la Oficina de Registros y Patentes de los Estados Unidos y también pueden estar registradas en otros países.

Free Manuals Download Website

<http://myh66.com>

<http://usermanuals.us>

<http://www.somanuals.com>

<http://www.4manuals.cc>

<http://www.manual-lib.com>

<http://www.404manual.com>

<http://www.luxmanual.com>

<http://aubethermostatmanual.com>

Golf course search by state

<http://golfingnear.com>

Email search by domain

<http://emailbydomain.com>

Auto manuals search

<http://auto.somanuals.com>

TV manuals search

<http://tv.somanuals.com>